



TOOLS & ACCESSORIES CATALOG

*Your Full-Line Supplier for the Utility,
Telecommunications, & Tree Care Industry*

*ALTEC SUPPLY OFFERS FULL LINES FROM ALL SUPPLIERS IN THIS CATALOG.
Please Call 1-877-GO ALTEC (1-877-462-5832) for More Information.**

** Not all Products are Available in All Markets*



Altec Supply is a leading provider of tools, accessories, and other supplies related to the electric utility, telecommunications, and tree care industry. With over 11,000 products from nearly 200 suppliers and nationwide sales and distribution capabilities, Altec Supply can rapidly and cost effectively meet the needs of its diverse customer base.

**Please call 1-877-GO ALTEC (1-877-462-5832)
for all of your Tools and Accessories needs.**

TABLE OF CONTENTS

CUSTOMIZED TRUCK KITS	6
SUPPLY LINES	10
ALTEC CONNECT	11
APPRENTICE KIT GUIDE	12
TOY TRUCKS	14

SAFETY EQUIPMENT

Bone Safety Equipment	16
Traffic Safety Equipment	20
Truck Safety - Outrigger Pads	23
Truck Safety - Barricade Equipment	24
Personal Safety Equipment	25
Miscellaneous Safety Equipment	28
American Polywater Corporation	
Cleaners, Degreasers, Maintenance	28
ZOLL AED Plus Emergency Equipment	30
Emergency Equipment	31
Crossfire Protective Eyewear	32
Wolf Peak Edge Safety Eyewear	35

PERSONAL EQUIPMENT

Bashlin Climbing Equipment	36
Capital Safety Equipment	41
Buckingham Climbing Equipment	47
Klein Climbing Equipment	58
Bulwark Flame Resistant Apparel	60
Bashlin Journeyman Lineman's Wear	72
Tingley Rubber - High Vis. Wear	77
NASCO Protective Outerwear	82
Majestic BlazeTek Clothing/Outerwear	84
Hoffman Boots	86
Wesco Boots	92
Tingley Overshoes/Boots	96
PIP Hard Hats	97
PIP Industrial Hand Protection - Gloves	98
Klein Gloves	100
Gloves - Other	102
Salsibury Gloves	103
Glove Bags	103

WORKSITE EQUIPMENT

Rainbow Technology Products	104
OshKosh Worksite Equipment	108

WORKSITE EQUIPMENT, continued

Tiiger Pole Pulling Equipment	112
Little Giant Ladders	114
Miscellaneous Worksite Equipment	116
Equipment Bags	118

PLATFORM ACCESSORIES

Klein Equipment Tool Storage	119
Pelican Mobile Tool Chest	122
Hastings Bucket Accessories	122
Altec Supply Tool Organizers	123
Platform Safety Hooks	125
Altec Supply Platform Tool Trays	126
Tool Specific Cases/holders	127
Tool Boards	130
Tool Aprons	131
Ergonomic Liners & Scuff Pads	132
Jameson Tool Holders	133
Miscellaneous Platform Equipment	134
Platform Covers	135
Utility Solutions Platform Equipment	136

TRUCK ACCESSORIES

IGLOO Coolers & Ice Chests	137
Pelican Pro-Elite Coolers & Ice Chests	138
Coolers & Accessories	139
Wheel Chocks	140
Outrigger Pads	140
Altarnamats Ground Cover Equipment	141
SVE Ground Cover Equipment	142
Sensata Technologies Inverters	143
SVP Mobile Desk Systems	144
Altec Back-Up Camera	147
Federal Signal Back-Up Camera	147
Mobile Desk Systems	148
Link Cat's Eye	151
The Reel Thing	151
Aircraft Dynamics RoboReels	152
KH Industries Cord Reels & Caddies	154
Hannay Reels & Accessories	156
ReelTech Reels	157
Molex Reels	158
Reels & Accessories	160
Hastings Truck Accessories	162

TRUCK ACCESSORIES

PriorityStart! Promax	163
Truck Barricade Kits	163
Miscellaneous Truck Accessories	164
General Machine Truck Accessories	166
Throttle Control System	166
Pintle Hooks	167
Truck Body Accessories	167
Hinges & Rubber Accessories	170
Tail Lights - Incandescent & LED	171
Strikers, Striker Plates, & Springs	171
Locks	171
Latches	172
Replacement Accessories	173

CRANE ACCESSORIES

Crane Accessories	174
-------------------	-----

LIGHTING EQUIPMENT

Streamlight Lighting	176
Molex Lighting	186
Federal Signal Lighting	188
Whelen Lighting	190
KH Industries Lighting	192
PSE Amber Lighting	197
Golight Lighting Solutions	198
Pelican Lighting	200
Aircraft Dynamics Lighting	202
General Machine Light Kits	205
Milwaukee Battery-Powered Lighting	205
Truck-Lite Lighting	206
Makita Lighting	207
Reflective Lamps	208
Hotline Lighting	208
Beacons	208
Compartment Rope Lighting	209
Mounted Lighting	209
Pole End Lighting	209
Miscellaneous Lighting	210

GRIPS, HOISTS, & RIGGING

Klein Grips & Hoist	211
Klein Grips Charts	216
Coffing Hoist/Little Mule Grips	218

GRIPS, HOISTS, & RIGGING, continued

Coffing Hoist/Little Mule Hoists	218
Hubbell / Chance Hoists	222
Hubbell / Chance Hoists Accessories	223
Maasdam Hoists	225
Harrington Hoists	225
Lincoln Hoists	226
LUG-ALL Web Strap Pullers	228
Hook International Hoists	230
Hoist Conversion Chart	232
Hastings Handline Equipment	233
Klein Handline Equipment	234
Handline Equipment	236
Ruegg Rollers	236
Hubbell / Chance Pulling Grips	237
Molex Pulling Grips	238
Lewis Manufacturing Pulling Grips	239
Lewis Manufacturing Swivels	244
Lewis Tarps and Buk Bags	247
Pulling Eyes	248
Chain Slings & Lifting Accessories	248
Transformer Slings	249
Campbell Shackles	250
Columbus McKinnon Shackles	252
Crosby Shackles	253
Campbell Blocks	253
Crosby Snatch Blocks	253
Hubbell / Chance Blocks	254
Stringing Equipment	255
AlaskaAug Stringing Equipment	256
Spider Pilot Line System	256

HAND TOOLS

SMALL HAND TOOLS

Altec Hand Tools	257
Greenlee Hand Tools	258
Klein Hand Tools	262
Apex Hand Tools	270
Milwaukee Hand Tools	276
Hubbell / Chance Hand Tools	279
Lowell Wrenches	282
Rauckman BugWrench	284
Speed Systems Hand Tools	285

SCORERS & STRIPPERS

Klein Scorers & Strippers	286
Greenlee Scorers & Strippers	287
Speed Systems Scorers & Strippers	290
Primary Distribution Tool Kits	291
Ripley Secondary Distribution Tools	291
Miscellaneous Scorers & Strippers	292

MANUAL CUTTERS & CRIMPERS

Greenlee Manual Cutters/Crimpers	294
Klein Manual Cutters/Crimpers	300
Burndy Manual Cutters/Crimpers	302
H.K. Porter / Apex Manual Cutters/Crimpers	304
Hastings Manual Cutters/Crimpers	305
Hubbell / Chance Manual Cutters/Crimpers	306
AMPACT Tools	306
Ideal Manual Cutters/Crimpers	307

POWER TOOLS:**BATTERY-POWERED TOOLS**

Greenlee Battery-Powered Tools	308
Burndy Battery-Powered Tools	320
Milwaukee Battery-Powered Tools	322
Makita Battery-Powered Tools	334
Aircraft Dynamics Battery-Powered	340

COMPRESSION DIES

CU / AL Die Selection Chart	342
Huskie "HT" Series Dies	343
Kearney "O" Style Dies	343
"W" Style Dies	343
"U" Style Dies (12 Ton)	343
HT41 Series Dies	346
HTK Series Dies (12 Ton)	346
HT61 Series Dies	346
HA60 Series Dies	347
ALCOA 60 Ton Series Dies	347
HA610 Series Dies	347
ALCOA 100 Ton Series Dies	347

HYDRAULIC TOOLS & ACCESSORIES

Greenlee Utility Hydraulic Tools	348
Burndy Hydraulic Tools	362

HYDRAULIC TOOLS & ACCESSORIES

Aircraft Dynamic Hydraulic Equipment	365
Tiiger Hydraulic Equipment	366
Stanley Hydraulic Tools	368
Wright Tool Hydraulic Accessories	373
Impact Wrench & Drill Accessories	373
High Pressure Hydraulic Accessories	374
Hydraulic Tools & Accessories	374
Hydraulic Tool Replacement Parts	377
Hydraulic Tool Assemblies	377

GAS POWERED TOOLS

Tanaka & Stihl Gas-Powered Tools	380
Power Units	382
Stanley Portable Power Units	383
Gas-Powered Pumps	384
Sievert Torch & Accessories	384

ELECTRIC TOOLS

Aircraft Dynamics Electric Tools	385
Milwaukee Electric Tools	386
Makita Electric Tools	388

**AIR COMPRESSION
PNEUMATIC EQUIPMENT**

Cooper Power Impact Wrench	389
Paslode Utility Stapler	389
American Pneumatic Backfill Tamper	389
Vanair Air Compression Systems	390

GROUNDING EQUIPMENT

Grounding & Mechanical Jumper Assemblies	395
Hubbell / Chance Grounding Equipment	397
Hastings Grounding Equipment	404
Grounding Equipment	410
Bashlin Grounding Equipment	411

HOT LINE EQUIPMENT

Hubbell / Chance Hot Line Equipment	412
Hastings Hot Line Equipment	442
Rauckman Utility Hot Line Products	460
Speed System Hot Line Products	461

HOT LINE EQUIPMENT

MADI Hot Line Products	462
Hot Line Equipment	464
Utility Solutions Hot Line Equipment	465

RUBBER GOODS & ACCESSORIES

Hubbell / Chance Insulating Covers	466
Salisbury Insulating Covers & Accessories	468
Bierer Pole Guards	470
Hastings Rubber Goods & Cover-Ups	471
Hubbell / Chance Lineman Grade Gloves	472
PIP Novax Rubber Insulating Gloves	475
Salisbury Lineman's Gloves	478
Salisbury Lineman's Protectors & Sleeves	479
Salisbury Glove Bags & Accessories	480

UNDERGROUND TOOLS & EQUIPMENT

Greenlee Underground Equipment	482
Jameson Underground Equipment	488
Puregas Underground Equipment	490
Utility Solutions Underground Equipment	491
Cable Tape & Lubricants	492
Underground Equipment	492
GMP Underground Equipment	493

AUGERS EQUIPMENT

Pengo Augers & Equipment	510
Lewis Auger Tarps and Buk Bags	527
Alaskaug Augers by Auger Tech	528
Auger Accessories	530
Auger Dirt Slings	530

ROPES

Ropes	531
Rope Accessories	534
Dynamometers	536

ELECTRICAL TEST EQUIPMENT

Utility Solutions Test Equipment	537
Milwaukee Test Equipment	538
Greenlee Test Equipment	540
Hubbell / Chance Electrical Test	544
HD Electric Electrical Test	546
Klein Electrical Test Equipment	549
Bierer Electrical Test Equipment	550
Hastings Test Equipment	552
Testers & Equipment	553

ARBORIST EQUIPMENT

Apex Arborist Equipment	555
Klein Arborist Equipment	558
Bashlin Arborist Equipment	560
Buckingham Arborist Equipment	563
Samson Arborist Ropes	564
Teufelberger / New England Arborist Ropes	565
Ropes	568
Pole Saws	570
Equipment Storage Bags	570
Pruner Tools & Accessories	571
Logging Tools	572
Platform Accessories	573
Safety Equipment	574
Tree Care Equipment	575
Jameson Fiberglass Poles	576
Altec Chipper	577

ALTEC TREE CARE	578
ALTEC CAPITAL	579
GLOBAL RENTAL	580
ALTEC NUECO	581
APPENDIX A: FITTINGS & ADAPTERS	582
REPLACEMENT PARTS	586
FULL LINE SUPPLIERS	587
TOOL REPAIR PROGRAM	588
SERVICE CENTERS	589

PRODUCT INDEX:	
BY ALTEC ITEM NUMBER	590
BY SUPPLIER ITEM NUMBER	610
BY ALPHABETICAL KEYWORD	642

OUTFIT YOUR AERIAL TRUCKS

*ALTEC SUPPLY'S TRUCK
KITS MAKE TOOLING A
TRUCK EASY*

AERIAL TRUCK KIT RECOMMENDATIONS

GRIPS, HOISTS, & RIGGING:

Lineman's Strap Hoist (3)
Grips - Sizes 20, 30, 40, 50 (4 of Each)
Handline Swivel Snap Hook (1)
Handline Hook (1)
Handline Block (1)
Slack Block Set (2)
1/2" Diameter Rope, 120' Long
Nylon Slings - 2" x 4', 6', or 8' (2 of Each)

GROUNDING EQUIPMENT:

Screw in Ground (1)
Cluster Ground (1)
Insulating Blanket, 6 Eyelets (2)
Clamp Pin for Rubber Glove (4)
Class 3 Insulating Short Lip Flexible Line Hose (2)
4/0 Grounding Assembly, 20' long (1)
4/0 Orange Mechanical Jumper Cable Assembly; 12' long (3)
2/0 Yellow Cable Grounding Assembly; 10' long (3)

MISCELLANEOUS EQUIPMENT:

Phase Sequence Indicator (1)
5 Gallon Water Cooler (1)
Gas Can, 1 Gallon (1)
Automated External Defibrillator (1)

HAND & POWER TOOLS & ACCESSORIES:

Heavyweight Hacksaw (1)
Bolt Cutters (1)
MD6 Tool (1)
Drill Bits - 9/16" x 18", 11/16" x 18", 13/16" x 18" (1 of Each)
W-O, W-C, WK840 Dies (1)
Crimping XPJ Tool (1)
Chain Saw - 18" (1)
Reversible Gas Drill with Bits (1)
Sledgehammer (1)
Hydraulic Impact Wrench Assembly (1)

HOT LINE TOOLS:

Hold Stick (1)
Shotgun Stick (1)
Hot Cutters (1)
Uni-Stick (1)
Rotary Blade (1)
Rotary Prong (1)
Ratchet Cutter (1)
Voltmeter (1)
Switchhead (1)

 Altec
Supply

PLEASE CONTACT YOUR LOCAL ALTEC SUPPLY
ACCOUNT MANAGER OR CALL 1-877-GO ALTEC
(1-877-462-5832) FOR PRICING

CUSTOM TRUCK KITS



OUTFIT YOUR DERRICK TRUCKS



CUSTOM TRUCK KITS

DERRICK TRUCK KIT RECOMMENDATIONS

GRIPS, HOISTS, & RIGGING:

- 1 1/2 Ton Chain Hoist (2)
- Steel Chokers - 1/2" x 6', 3/8" x 6', 1/2" x 8', 3/8" x 4' (2 of Each)
- Nylon Slings - 2" x 4', 2" x 6', 2" x 8' (2 of Each)
- Shackles - 5/8" and 3/4" (2 of Each)
- Bulldog Grip (1)
- Guy Puller (1)

GROUNDING EQUIPMENT:

- 4/0 Grounding Assembly, 20' Long (1)
- Screw in Ground (1)

WORKSITE EQUIPMENT:

- Sharpshooter Shovel (1)
- 5' Round Point Shovel (2)
- Hand Tamp (1)
- Hydraulic Tamp Assembly (1)

- Banjo 9' Ash Shovel (1)
- Sledgehammer (1)
- Post Hole Digger (Set of Jobbers) (1)
- Lifting Tong (1)
- Spoon (1)
- Cant Hook (1)
- 36" Bolt Cutters (1)
- 5 Gallon Water Cooler (1)

ANCHOR TOOLING:

- Locking Dog Assembly (1)
- Kelly Bar Adapter, Bent Arm Pin (1)
- Kelly Bar Adapter - For Installation of SS /RR Anchors (1)
- 7' Drive End Wrench (1)

- Automated External Defibrillator (1)

PLEASE CONTACT YOUR LOCAL ALTEC SUPPLY
ACCOUNT MANAGER OR CALL 1-877-GO ALTEC
(1-877-462-5832) FOR PRICING



OUTFIT YOUR TELECOMMUNICATIONS UNITS



SAFETY ACCESSORIES:

Orange Reflective Safety Cones; 28" X 14" X 14" Square Base (2)
Sign; Hi-Intensity; Reflective; 24/7; Utility Construction Ahead (1)
Sign Stand; Single Spring; With Auto Latch (1)
5 Gallon Cooler (1)

PLATFORM ACCESSORIES:

S Hook (1 Pair)
Heavy Reinforced Oval Canvas Bucket; 14 X 7 X 9 (1)
Canvas Round Tool Bucket, 12" X 15" (1)

LIGHTING:

Headlamp (1)
Streamlight Knucklehead (1)
Cradle Light & Battery (1)
Standard Litebox System, Yellow (1)
Spotlight (1)
Hand-held Septor (1)

WORKSITE EQUIPMENT:

Sharpshooter Spade/Shovel (1)
Round Point Shovel (1)

BATTERY-POWERED EQUIPMENT:

Sawzall Kit, 18V Lithium-Ion (1)
Hammer Drill Kit, 18V Lithium-Ion (1)

UNDERGROUND EQUIPMENT:

Manhole Cover Lifters/Compatible Hooks (1)
Stp/Utp; Flat Satin Cable 22-28 AWG (1)
Wire Raiser, WR-1 (1)
Cushion Grip Insertion/Extraction Tool; For F-Connectors (1)
Duct Hunter Traceable Rodder (1)

HAND & POWER TOOLS & ACCESSORIES:

Electrician's Straight Claw Hammer (1)
3# Hand Drilling Hammer (1)
7 Piece Screwdriver Set (1)
7 Piece Nut Driver Set (1)
Magnetic Nut Driver Set (1)
Scotchlok Crimping Plier (1)
Utility Knife (1)
Ergonomic Skinning Knife (1)
High Leverage Diagonal Pliers (1)
High Leverage Journeyman Side Cutting Pliers (1)
High Leverage NE-Type Side Cutters (1)
Can Wrench (1)
Cable Splicers Kit (1)
Standard Cable Cutters (1)
Bolt Cutters (1)
Ratcheting Modular Crimper/Stripper (1)
Wire Stripper/Cutter (1)
Ratcheting PVC Cutters (1)
High-Leverage Cable Cutters, 9.5" Long (1)
Ratcheting Cable Cutters, 10" Long (1)
3 Piece Free Fall Cable Splicers Kit (1)
TW Torque Wrench Basic Angles Head (1)
5-in-1 Lineman's Wrench (1)
18" Nailcutter Impact Bits; 9/16 Diameter (1)
18" Nailcutter Impact Bits; 11/16 Diameter (1)
18" Nailcutter Impact Bits; 13/16 Diameter (1)
18" Nailcutter Impact Bits; 15/16 Diameter (1)



PLEASE CONTACT YOUR LOCAL ALTEC SUPPLY
ACCOUNT MANAGER OR CALL 1-877-GO ALTEC
(1-877-462-5832) FOR PRICING

CUSTOM TRUCK KITS

OUTFIT YOUR TREE TRIMMER TRUCKS

TREE TRIMMER TRUCK KIT RECOMMENDATIONS

TREE TRIMMING PACKAGE:

Pruner (1)
Hand Saw (1)
Wire and Limb Raiser (1)
12' of Extension Poles

POWER EQUIPMENT:

Gas Chain Saw, Stihl MS250 (1)
Hydraulic Long Reach Chain Saw, 13" Cut (1)

HANDLINE EQUIPMENT:

Flipline - 1/2" (1)
1/2" X 150' Climbing Rope, Braided Safety Blue (1)
Bull Rope, Polyester Double Braid, 5/8" X 600' (1)

PLATFORM EQUIPMENT:

Tool Tray (1)
Vinyl Round Tool Bucket (1)
Chain Saw Holder (1)
Boom-Mounted Long Reach Hydraulic Saw Holder (1)

WORKSITE EQUIPMENT:

Cant Hook, 4.5' Long (1)
Pole Lifting Tongs (1)
Men Working Roll Up Sign And Stand (1)
Safety Cones, (4)
Tree Climbing Saddle (1)
Tree Climbers, Pair (1)

SAFETY EQUIPMENT:

Hard Hat (1)
Go-Light Radio Remote Control Light (1)
Streamlight Septor Hard Hat Light (1)
Class 3 Safety Vest (1)

PLEASE CONTACT YOUR LOCAL ALTEC SUPPLY ACCOUNT MANAGER OR CALL 1-877-GO ALTEC (1-877-462-5832) FOR PRICING

CUSTOM TRUCK KITS



 Altec Supply

Safety Equipment

Traffic Safety Equipment
Truck Safety Equipment
Personal Safety Equipment
Aerial Emergency Rescue Systems
Climbers & Climbing Saddles
Fall Protection Equipment
Full Body Harnesses
Fire Extinguishers
Hard Hats
Voltage Detectors
Safety Cones

Hydraulic Tools & Accessories

Impact Wrenches & Drills
Pole Tampers
Standard & Pistol Grip Chain Saws
Long Reach Hydraulic Tools
Crimping Tools
Alternators & Pumps
Sign Post Drivers & Post Pullers
Rock Drills & Chipping Hammers
Reels, Ball Stops, & Reel Ball Swivels
Ground Rod Drivers & Pole Pullers
Paving Breakers
Submersible Pumps
Non-Conductive Tool Hoses
High Pressure Tools
Hydraulic Tool Replacement Parts
Low Pressure Hydraulic Assemblies

Battery Powered Tools

Crimping Tools
Crimping Dies
Dieless Crimping Tools
6 Ton, 12 Ton, 15 Ton Tools
Multipurpose Tools
Cut & Punch Tools
Utility Stapler

Manual Cutters & Crimpers

Ratcheting Tools
Hydraulic Cutters & Crimpers
Bolt Cutters
Guy Strand Cutters
Amp Tools

Grounding Equipment

Grounding Assemblies
Mechanical Jumper Assemblies
C-Type Grounding Clamps
Ferrules
Jumper Clamps

Hotline Tools

Mechanical & Powered Hoists
Anchor Tools & Assemblies
Auxiliary Arm Assembly
Torque Indicators
Gins
Truck Grounding Equipment
Conductor Support Equipment
Electrical Test Equipment
Clampsticks
Elbow Pullers
Universal Poles & Tool Kits
Arc Snuffer Tools
Telescoping Sticks

Measuring Sticks
Disconnect Sticks
Hot Stick Care & Storage
Rubber Insulating Blankets
Line Hose & Covers
Ladders
Hot Line Tool Accessories
Link Sticks
Wire Holding Sticks
Hot Sticks & Cutters
Shotgun Sticks
Switch & Disconnect Sticks
Link Sticks
Arm Assemblies
Hot Line Tools Cleaning & Repair

Augers & Auger Accessories

Dirt & Carbide Augers
Bullet & Rock Augers
Bullet Tooth & Step Rock Augers
Auger Fast Change System
Shank Plates
Auger Teeth
Pilot Bits & Adaptors

Scorers & Strippers

Primary Distribution Tool Kits
Secondary Distribution Tools
Scorers & Strippers

Truck Accessories

Capstan Heads & Capstan Drives
The Reel Thing
Pintle Hooks
Hydraulic Reel Ball Stops & Swivels
Reels
Truck Cab Organizers
Throttle Control System
Voltage Regulators
Inverters
Truck Mounted Body Accessories
Ground Protection Truck Accessories
Hinges & Rubber Accessories
Incandescent & LED Taillights
Strikers, Striker Plates, & Springs
Hooks, Plates, & Latches

Platform Accessories

Canvas Tool Organizers
Tool Organizers Boards
Tool Trays
Tool Specific Holders
Platform Lighting
Tool Aprons
Rigid and Vinyl Platform Covers
Ergonomic Liners
Scuff Pads
Platform Steps

Hand Tools

Tool Pouches & Bags
Tool Kits
Hand Tools
Insulated Tools
Measuring Tools
Nut Drivers & Screwdrivers
Pliers, Wrenches, & Knives
Hacksaws
Hammers

Personal Equipment

Hard Hats
Winter Liners
Cooling Apparel
Gloves & Glove Bags
Rubber Glove & Sleeve Bags
Equipment Bags
Personal Rain Gear
Safety Glasses
Protective Clothing
Climbing Equipment
Lineman's Gloves & Liners
Leather Protectors
Sleeves
Protective Overshoes
Rubber Goods Accessories & Cleaners
Conductive Clothing

Lighting & Lighting Equipment

Strobe & Halogen Beacons
Area Lighting
Directional Lighting
Pole Trailer Lighting
Cyclops Flashlights
LED Compartment Lighting
Hot Stick Lighting
Streamlight LiteBox[®] Series
Streamlight Vulcan[®] Series
Streamlight Stinger[®] Series
Streamlight SL Series
Streamlight Stylus[®] Series
Streamlight Task-Light[®] Series
Streamlight Scorpion
Streamlight Headlamp Series
Streamlight Jr.[®] Flashlights

Ropes & Accessories

Double Braided Rope
Polyester Rope
Twelve Strand Weave
Swivels
Screw Pin Shackles
Snatch Blocks
Dollies

Lifting Tools & Accessories

Hoists & Accessories
Grips
Handline Tools
Block & Tackle
Pulling Grips
Banding Tools & Sock Bands
Swivels

Gas Powered Tools

Saws
Pumps
Augers
Power Units
Gas Engine Drills

Electrical Test Equipment

Voltage Testers
Multimeters
Clamp Meters
Clamp-On Adapters & Meters
High Voltage Testers
Hot Stick Testers
Phasing Testers

Dual Range Meters
Buried Line Locator
Dynamometers
Phase Sequence Indicators
Motor Rotation Testers
Personal Voltage Detectors

Worksite Accessories

Shovels
Spoons
Digging Bars
Lifting & Skidding Tongs
Lug Hooks
Cant Hooks
Peavies
Tamp Bars
Post Hole Diggers
Pole Cradle
Dirt Slings
Sledge Hammers
Pole Setting Foam
Weed Killer & Insecticides
Probes

Tree Care Accessories

Logging Tools
Pole Pruners
Hydraulic Saws
Gas Powered Saws
Ropes
Pole Saws
Equipment Storage Bags
Climbing Equipment
Hand Pruners
Lopping Shears
Hand Saws & Scabbards

Underground Accessories

Manhole Equipment
Manhole Tents & Umbrellas
Hose Ducting
Ventilators & Ventilator Hoses
Cable Guides & Accessories
Cable Feeders & Accessories
Cable Bending & Pulling
Cable Blower
Pulling Eyes
Harnesses, Links, & Collars
Pulling Grips
Swivels & Clevis
Mandrels & Shackles
Conduit Cleaning & Lubrication
Cable Tapes & Lubricants
Power Fishing System
Heating & Cooling Equipment
Duct Rodders & Reel Jacks
Scorers & Strippers
Submersible Pumps

Altec Connect is Altec's website for all of your parts, tools and accessories needs. Over 50,000 items are available to order directly from Altec via the internet. View Altec Supply's extensive Tools and Accessories Catalog and Quarterly Specials. Also view unit manuals, schematics, and bills of material.

The screenshot shows the Altec Connect website. On the left is a 'Quick Order Form' with columns for Quantity and Part Number. The main content area displays the 'Altec Supply' logo and a search bar. Below the search bar, there are navigation tabs: Home, Unit Information and Manuals, Tools and Accessories, Parts, Shopping Lists, Orders, and Invoices. A search bar contains 'Part Number' and a 'Go' button. Below the search bar, there are two product listings: 'Long Needle-Nose Pliers' and 'Needle-Nose Pliers - Side-Cutting'. The 'Long Needle-Nose Pliers' listing includes a description, features, and a 'Buy' button. The 'Needle-Nose Pliers - Side-Cutting' listing includes a description and a 'Buy' button. On the left side of the main content area, there is a 'Browse' menu with categories like Tools and Accessories, Catalog, Hand Tools - Reamed, Insulated Tools, Klein Hammers, Klein Nut Drivers and Screwdrivers, Wrenches, Klein Measuring Tools, Hacksaws, Knives & Accessories, Heavy Duty Socket Wrenches - 51 & 151T Lowall Wrenches, Allen Falso Wrench with Pentia Head, Lowall Tower Wrench, and Economic Spinning Tools.

- Search by part number or description to identify parts you need
- Utilize pricing, and "real time" availability
- Create a permanent shopping cart or shopping list for repeat orders
- Build orders online and save cart until orders are ready to be placed
- Personally manage billing, shipping, and other account information
- Experience direct access to order status and detailed tracking information
- View and print parts invoices and parts order histories

Fleet Information

- See all equipment registered to your company, including locations of units
- View customer service notices

Unit Manuals

- Access the most current parts manuals for your units
- Search for unit information by serial number, work order number, or VIN
- View unit and final assembly bills of material
- View operators and maintenance manuals

Altec Supply

- Easy to use catalog and quarterly specials
- Photos and complete descriptions of tools and accessories

START USING ALTEC CONNECT:

- 1) Go to www.alteconnect.com
- 2) Click on the "Not Registered?" link in the upper right hand corner
- 3) Fill out the required information (you must be an existing Altec customer to register)
- 4) A user name and password will be emailed to you shortly

Please call 877-GO ALTEC with any questions, or to request training on Altec Connect.

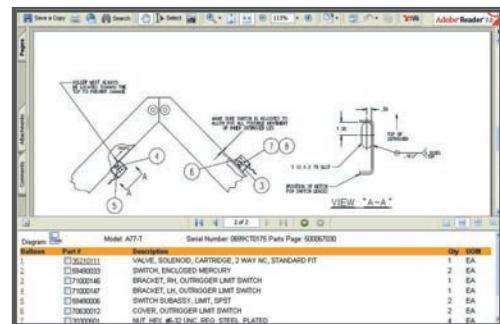

Apprentice Kit Guide

Obtaining the tools and accessories necessary to equip an apprentice is only a phone call away. Altec Supply will develop custom Apprentice Kits based on your specifications. To create your own customized kit, call your local sales representative or **1-877-GO ALTEC (1-877-462-5832)** and simply specify the tools and accessories you require.

APPRENTICE KITS

USA: 1-877-GO ALTEC
(1-877-462-5832)

www.alteconnect.com



CLIMBING BELTS
PAGES 36, 43, 48-49

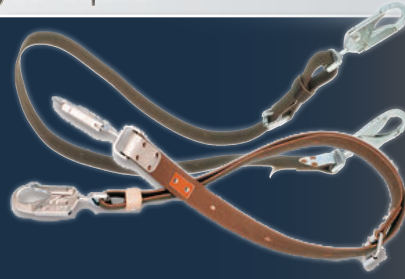

POSITIONING STRAPS
PAGES 38, 47, 59



HAND TOOLS
PAGES 38, 57



CLIMBING PADS
PAGES 38, 51



GAFF EQUIPMENT
PAGES 37, 50-51, 58-59



GLOVES
PAGES 100-103



TOOL HOLDERS
PAGES 38, 57



LANYARDS
PAGES 44-45, 47, 56



HARD HATS
PAGE 97



SAFETY GLASSES
PAGES 32-35



LINEMAN'S WEAR
PAGES 60-85



LINEMAN'S BOOTS
PAGE 86-96

Altec Supply Understands that Selecting Quality Apprentice Equipment is Important to the Lineman.

We offer a selection of tools and equipment from the brands our linemen have grown to trust and appreciate in the industry - including A.B. Chance, Bashlin, Buckingham, Greenlee, Hastings, Klein, Kunz, and Salisbury - just to name a few. Developing a custom Apprentice Kit based on your specifications is easy. Simply contact your account manager or call **1-877-GO ALTEC (1-877-462-5832)** and specify the tools and accessories you require.

Economical

Altec Supply is dedicated to providing a cost-effective method for apprentice linemen to purchase tools. Our commitment to linemen and other utility workers is to keep them working as safely as possible by economically supplying high quality tools and climbing equipment.

Reliable Sourcing

Altec Supply remains a leader in providing tools and accessories by maintaining competitive pricing and stocking critical items. In many cases, we will have your apprentice kits to you within 24 hours.

Customize Your Kit

Altec Supply will work to specifically meet the needs of apprentices. We supply tool kits, climbing kits, and other tools and accessories needed to meet your requirements. Contact your local Altec Supply account manager to develop custom apprentice kits.

Sample Apprentice List

<u>Qty</u>	
1	Steel Contoured Replaceable Gaff Climbers W/3502C & 6909U
1	5 Pocket Tool Pouch
1	Nut Bag (Black Bag)
1	6' Positioning Strap
1	Nylon Strap W/ Carabiner
1	Orange Vinyl Tool Bag W/ Shoulder Strap
1	V Gard Hard Hat With Ratchet Suspension Yellow
1	Safety Eye Glasses Anti Reflective Lens
1	Safety Eye Glasses Smoke Lens
1	Breakaway Hook
1	Wrench
1	Hickory Handle - Smooth Face #707
1	Heavy Duty Ins. 8" Round Shank Screwdriver
1	Hard Jaws Thread Chaser
1	Skinning Knife
1	Channel Lock 10" Pump Pliers
1	Folding Fiberglass Ruler
1	Heavy Duty Bug Wrench 9/16" And 3/4" Ends
1	12" Crescent Wrench W/ Dipped Handle
1	Belt
1	Dri-Line 10"
1	Long-Cuff Glove

Please Call 1-877-GO ALTEC (1-877-462-5832) or Contact Your Altec Supply Account Manager and Specify the Tools You Require to Create and Order Customized Kits.

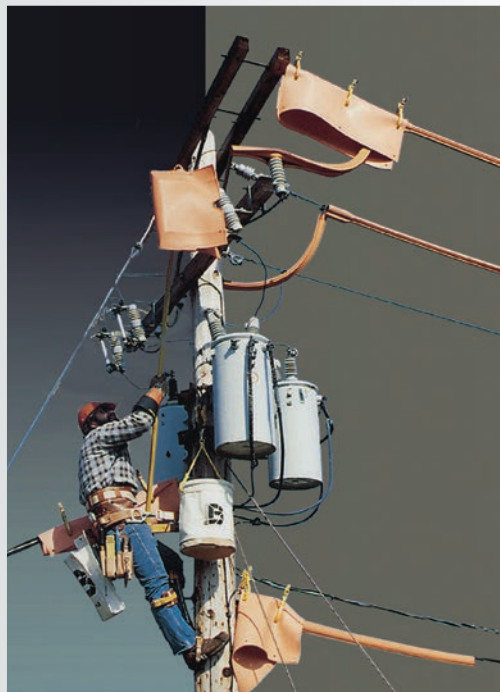

APPRENTICE KITS

USA: 1-877-GO ALTEC
(1-877-462-5832)

www.alteconnect.com

1:34 Scale Altec Die Cast Aerial & Digger Derrick Toy Trucks



P/N 9000-90090 Aerial Truck



P/N 9000-90091 Digger Derrick

- Both models feature authentic Altec markings, articulating booms and full unit rotation, full line body with adjustable outriggers, hand painted fire extinguisher and grounding reel, an opening hood on the cab with full engine detail, and two orange traffic cones
- P/N 9000-90090 also features articulating upper and lower booms, an extendable material handling jib, rear platform extension with pintle hook and tow rings, outrigger pads stored on racks beneath the body
- P/N 9000-90091 also features a telescoping boom that swivels 360° and is poseable in the up or down position, a center boom extension with cable and cable hook, an auger that is poseable in the working or traveling position, functioning pole guides, winch spool with cable, detailed operator's seat with joystick controls, rear deck hitch, tool reel, storage boxes, and a main boom rest with safety lights

1:34 Scale Altec Die Cast Tree Trimmer GMC C7500 with Overcenter Aerial Device

- Features authentic Altec markings, articulating boom and full unit rotation
- Full line body with adjustable outriggers and safety cones for display in front cone holder
- Opening hood on the cab with full engine detail
- Dump bed

P/N 9000-90093 Tree Trimmer





1:34 Scale Altec Die Cast Crane

- Features authentic Altec markings,
- Working material handling jib, winch, telescoping boom, downhold ball, and outriggers
- Opening hood on the cab with full engine detail
- Flatbed body and full unit rotation
- Cable sheaves, operator cab, tag axle, 2 part load hook

P/N 9000-90092



Telescoping boom is NOT shown fully extended

1:34 Scale Altec Die Cast AT40G

- Authentic Altec markings
- Fan adjustable, full rang swinging boom
- Opening hood on the cab with full engine detail
- Full unit rotation

P/N 9705-68772



DIE-CAST TOY TRUCKS

USA: 1-877-GO ALTEC
(1-877-462-5832)

www.alteccconnect.com



SafeZone Series Roll-Up Signs and Overlays

SAFETY EQUIPMENT

USA: 1-877-GO ALTEC
(1-877-462-5832)

www.alteconnect.com

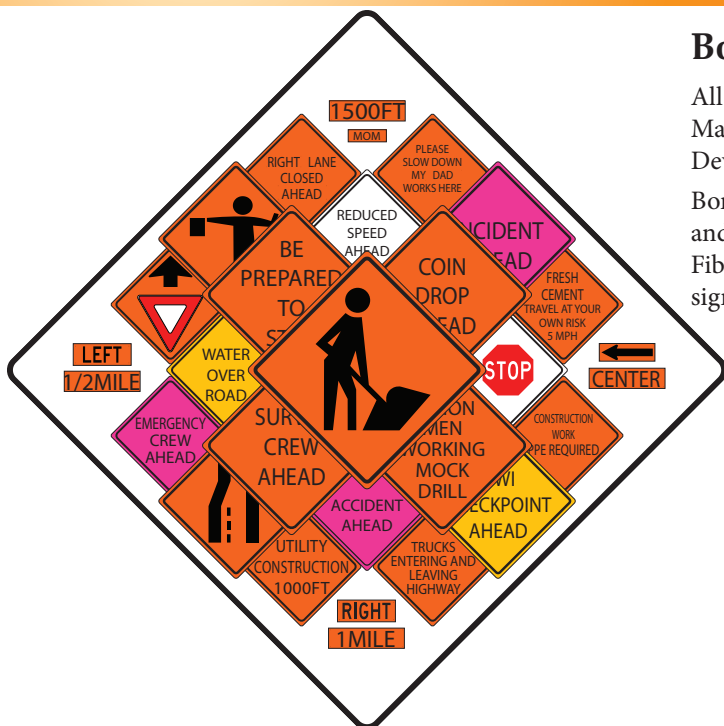

Bone Safety Signs

All signs are designed using the Standard Highway Signs Manual as specified in the Manual on Uniform Traffic Control Devices (MUTCD).

Bone Corner Pocket, Anti-Kiting Devices, Storage Strap and Reversible Snaps for Overlays option and Heavy Duty Fiberglass with Anti-Blooming are standard on all Roll-Up signs.



Super Bright (SB) Signs

This is one of Reflexite's most popular products. Super Bright fluorescent prismatic sign blanks are used by our customers to create the work zone signs you see on the road. As a motorist, you benefit from maximum visibility at long distances, day and night. Reflexite's color stability technology ensures a long and useful life. Super Bright colors are: fluorescent orange, non-fluorescent white, yellow and the new fluorescent pink color recommended for Incident Management applications.

Marathon (M) Signs

Reflexite's Roll-Up sign blanks which utilize Marathon Fluorescence take performance to a higher level. The longer lasting fluorescent color gives the sign a longer useful life and offers outstanding visibility, day and night. Higher levels of photometric performance ensure superior reflectivity at night and in low light conditions. Reflexite High Performance Marathon Fluorescence signs are available in the following colors: fluorescent orange, fluorescent yellow-green (lime), non-fluorescent white, and the new fluorescent yellow.

**Super Bright Model
NCHRP350 Approved**

Common Sign Overlays

The Signs and the Overlays are designed so that the overlay may be attached to the back of the sign for easy storage. Velcro may be used upon request. Velcro Overlay cannot be attached to the back of the sign for storage.

COMMON OVERLAYS		
LEGEND NAME	48" PREMIUM MESH OVERLAY	48" SUPER BRIGHT REFLECTIVE OVERLAY
LEFT	9703-75140 PMO-0823-LEFTOC	9702-71343 REO-0823-LEFTOC
RIGHT	9703-75141 PMO-0823-RIGHTOC	9702-51315 REO-0823-RIGHTOC
500 FT	9703-75142 PMO-0830-500FOC	9703-05482 REO-0830-500FOC
1000 FT	9703-75143 PMO-0830-1000FOC	9703-05483 REO-0830-1000FOC
1500 FT	9703-75144 PMO-0830-1500FOC	9703-05484 REO-0830-1500FOC
MERGE	9703-75145 PMO-1238-BLRMOC	9702-67923 REO-1238-BLRMOC



**Bone Safety's
Industry-Standard
Signs**



Super Bright Signs (Hi-Intensity Reflective Sheeting)



Marathon Signs



Non-Reflective Vinyl Signs (Daytime Use Only)



Mesh Signs (Daytime Use Only)

COMMON SIGNS		
LEGEND NAME	48" PREMIUM MESH (DAYTIME USE ONLY)	48" SUPER BRIGHT REFLECTIVE
FLAGGER AHEAD	9703-55944 PM4848FAOC	9701-56010 RE4848FAOC
ROAD CLOSED	9703-13573 PM4848RCOC	9702-46292 RE4848RCOC
LANE CLOSED AHEAD	9703-55955 PM4848LCAOC	9702-99675 RE4848LCAOC
MEN WORKING	9703-13575 PM4848MWOC	9702-46295 RE4848MWOC
WORKER (SYMBOL)	9703-55964 PM4848WSOC	9702-51325 RE4848WSOC
ONE LANE ROAD AHEAD	9703-55975 PM4848OLRAOC	9702-71341 RE4848OLRAOC
UTILITY CONSTRUCTION AHEAD	9703-55978 PM4848UCAOC	9701-56003 RE4848UCAOC
UTILITY WORK AHEAD	9702-74916 PM4848UWAOC	9702-07457 RE4848UWAOC
BE PREPARED TO STOP	9702-61116 PM4848BPTSOC	9702-71340 RE4848BPTSOC
UTILITY CONSTRUCTION 1 MILE	9702-82625 PM4848UC 1 MILE	9703-56939 RE4848UC 1 MILE
UTILITY CONSTRUCTION 1/2 MILE	9702-82631 PM4848UC 1/2 MILE	9703-56953 RE4848UC 1/2 MILE
RIGHT LANE CLOSED	9703-13576 PM4848RLCOC	9703-08121 RE4848RLCOC
RIGHT LANE CLOSED AHEAD	9703-55982 PM4848RLCAOC	9701-56004 RE4848RLCAOC
LEFT LANE CLOSED	9703-13577 PM4848LLCOC	9703-56956 RE4848LLCOC
LEFT LANE CLOSED AHEAD	9703-55985 PM4848LLCAOC	9702-51309 RE4848LLCAOC
FLAGGER (SYMBOL)	9702-82632 PM4848FSOC	9702-33756 RE4848FSOC
MERGE RIGHT (SYMBOL)	9703-13578 PM4848MRSOC	9703-56977 RE4848MRSOC
MERGE LEFT (SYMBOL)	9703-13579 PM4848MLSOC	9703-56978 RE4848MLSOC
DOUBLE MERGE RIGHT AND LEFT (SYMBOLS)	9703-56391 PM4848DMSOC	9702-67921 RE4848DMSOC
ROAD CONSTRUCTION AHEAD	9703-56394 PM4848RCA3OC	9702-51318 RE4848RCA3OC
ROAD WORK AHEAD	9703-56396 PM4848RWAOC	9702-99671 RE4848RWAOC
END CONSTRUCTION	9703-56400 PM4848ECOC	9701-96005 RE4848ECOC
ROAD CLOSED	9703-13573 PM4848RCOC	9702-46292 RE4848RCOC
DETOUR AHEAD	9703-56912 PM4848DETOUROC	9702-46294 RE4848DETOUROC
TREE WORK AHEAD	9703-56925 PM4848TWAOC	9702-46293 RE4848TWAOC
TRUCKS ENTERING HIGHWAY	9703-56928 PM4848TEHOC	9703-49028 RE4848TEHOC



SafeZone Series Stands

SAFETY EQUIPMENT

USA: 1-877-GO ALTEC
(1-877-462-5832)

www.alteconnect.com



9701-56009
SZ-412
NCHRP350 Approved

The SZ-412 is the right choice for Utility Companies, DOT's, City & County Governments or anyone working along secondary roads or inner city streets.

The SafeZone Series (P/N 9701-56009) SZ-412 is a super lightweight compact springless sign stand for use with Roll-Up signs. Easy to use and easy to store, its single sign attachment point allows for quick deployment in the field.

Universal Bracket

Allows the use of the SafeZone stands with most brands of roll-up signs



SafeZone Series Stand Features and Benefits

All SafeZone Series Sign Stands come with our patented Auto-Latch mechanism, unless our Universal Bracket is requested. The advantage of our Auto-Latch is the speed in which the sign is attached and released from our stands.

- Crash Design Breakaway Base
- Exclusive Quick Release System for all modular attachments and accessories
- Compact and Lightweight
- Bright Orange, UV Stabilized, Powder Coated Legs, for Safety, Durability
- Pull Pin and Kick Release for fast setup by hand or foot
- Simple Nut & Bolt Construction allows for fast repairs using basic hand tools
- Readily available Replacement Parts or Assemblies
- 3 Height Adjustments for Uneven Terrain
- Skid Resistant Rubber Feet

NCHRP-350 Certified

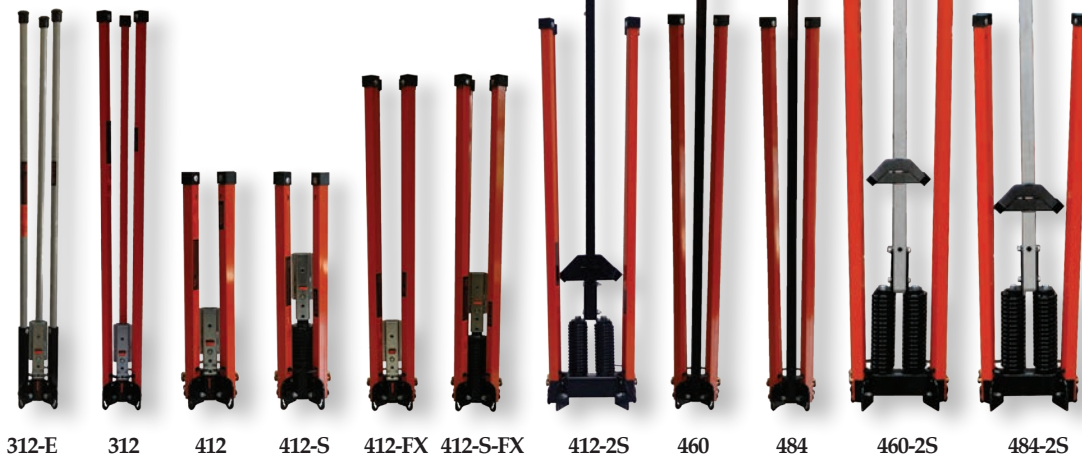

Standard Model	Springless	Springless with U-Bracket	Single Spring	Single Spring with U-Bracket	Dual Spring (Rigid Sign Stand)	Dual Spring with Roll-Up Bracket (Rigid Sign Stand)
Model SZ-412 1' Stand (4 LEGS, 12" OFF GROUND)	9701-56009 SZ-412	9702-83761 SZ-412-UB	9701-56008 SZ-412-S	9702-99679 SZ-412-S-UB	9702-84690 SZ-412-2S	9701-77636 SZ-412-2S-RB
Model SZ-460 5' Stand (4 LEGS, 60" OFF GROUND)	9702-48822 SZ-460	9703-74980 SZ-460-UB	-	-	9703-74997 SZ-460-2S	9703-75006 SZ-460-2S-RB
Model SZ-484 7' Stand (4 LEGS, 84" OFF GROUND)	9703-75007 SZ-484	9703-75012 SZ-484-UB	-	-	9703-75019 SZ-484-2S	9703-75026 SZ-484-2S-RB



Traffic Control & OSHA Signs



SAFETY EQUIPMENT

USA: 1-877-GO ALTEC
(1-877-462-5832)

www.alteconnect.com



Bone Tele-Pole

The Safe Zone series STOP/SLOW paddle is designed to allow the staff to telescope from 54" to 84" for ease of use controlling traffic through temporary traffic control zone. It is available in reflective and non-reflective faces and comes in both 18" and 24" Sizes.

Safe

An ergonomically designed screw-type compression fitting on the telescopic mast, combined with a non skid rubber cap on the bottom of the HI-VIZ orange fiberglass mast makes the SafeZone Series paddle both simple and economical.

Durable

The pultruded hollow fiberglass mast coupled with the fiberglass reinforced plastic (FRP) sign face makes the SafeZone series STOP/SLOW paddle both lightweight and durable even in extreme temperatures and abrasive environments.



P/N 9701-55240 STOP-1812R
12" Hand Held Pole

Stop-N-Slow Paddles

Our Stop-N-Slow sign faces are made from the same BONELIGHT ACM used for our large construction signs or Reclaimed Aluminum and Virgin Aluminum. Available in 18" & 24" sizes and various reflective and non-reflective faces.



Stop-N-Slow Paddle
24" Face
Standard Reflective
84" Extendable Handle
P/N 9000-50467 STOP-2484R



Stop-N-Slow Paddle
24" Hi-Intensity Reflective
84" Extendable Handle
P/N 9702-62793 STOP-2484HI



Stop-N-Slow Paddle
Combination Model
24" Diamond Grade
Hi-Intensity Reflective
84" Extendable Handle
P/N 9703-55933 STOP-2484DG/HI

P/N 9701-56012 STOP-1884R
Tele-Pole



Stop-N-Slow Covers

A fluorescent orange cover will add longer life to the paddles.

P/N 9701-60915 STOP-COVER-18 18" COVER
P/N 9701-80326 STOP-COVER-24 24" COVER



OSHA Signs

Helping you meet the federal OSHA guideline for 1910 or 1926 for indoor or outdoor use.

TRAFFIC SAFETY EQUIPMENT

SAFETY EQUIPMENT

USA: 1-877-GO ALTEC
(1-877-462-5832)

www.alteconnect.com

Roll-Up Stop/Slow Paddle



- Controlling traffic around work sites becomes much easier with this dependable dual purpose roll-up sign.
- Sign is available in either 18" or 24"
- Complies with MUTCD standards
- Made of diamond grade roll-up material
- Lightweight for easy deployment

Includes 3-piece 6' plastic staff and heavy-duty storage bag

P/N 9000-01325 18"
P/N 9000-01327 24"

Super-Flex Mast™ Sign Stand



- High performance, heavy-duty stand utilizing the Super-Flex Mast™ adjustable fiberglass leaf-spring with a compact half-mast for all roll-up signs
- Quickly sets-up and sign height is easily adjustable
- Offers wind-deflection for best "target value" and

proven "blowovers" resistance

- Folds-up very compactly, is lightweight, and easy-to-use
- Rugged galvanized-steel two-position telescoping legs with non-skid rubber leg-tips adjust for narrow shoulders and uneven terrain
- Stand folds to compact size for easy storage
- Ideal for open road
- Rated for 70 mph two-lane or four-lane highways using a 36" Roll-up C-Sign™ without ballast, and up to 65 mph using a 48" Roll-up C-Sign™ without ballast

P/N 9700-39013 Compact C-Stand

Aluminum Stop/Slow Paddle



- 18" or 24" available
- Complies with MUTCD standards
- Aluminum octagon paddle features high intensity reflective sheeting
- Includes 12" plastic staff
- Optional: add a 62" two-

piece plastic staff for 5' height requirements

P/N 9700-20729 18"
P/N 9700-20722 24"
P/N 9700-20644 5' (62") PVC Staff

"D" Warning Flag



- 18" square vinyl-coated nylon flag
- Bright fluorescent orange for extra visibility
- Each flag has a sewn-in diagonal stay keeping it rigid for increased visibility
- Wooden staff is 24" long by 3/4" diameter
- Each flag has a weight of 6 oz.

P/N 660-21048

Standard Non-Reflective Roll-Up Signs



- 48" square vinyl non-reflective flag
- Bright fluorescent orange for extra visibility
- Each flag has vertical and horizontal fiberglass ribs to keep it rigid for increased visibility
- Features 4 pockets to hold the ribs -2 delta and 2 full
- Accommodates the following sign holder types: Screwlock™, Pocket Holder, and R.U. Bracket

P/N 9701-03994 48" Utility Work Ahead

P/N 9701-03995 48" Men Working

P/N 9000-00350 48" Flag Man Ahead

P/N 9000-00454 48" Worker Symbol

Warning Placard



- Reflective striping for visibility
- 2 straps to secure warning to pole warning placard for tree crews
- The warning states "Do Not Energize Workers on Lines"

P/N 9701-33854

Folding Flag System



- Keeps 18" x 18" vinyl flags with sign panel and rolls up inside panel for protection
- Easily installed onto existing signs
- To deploy, pivot flag staff into position and slide clip down

P/N 9000-07628

TRAFFIC SAFETY EQUIPMENT

Wind Resistant Roll-Up Safety System

Wind-Resistant Roll-Up Sign



- Available in 36" or 48" sizes
- These signs feature a highly reflective surface for maximum visibility in all conditions
- Rib supports are designed for use with screw lock, channel, or pocket style sign panel holders
- Signs include Velcro® anti-kiting and storage straps

P/N 9000-99715 36" Men Working Sign
 P/N 9000-99924 36" Worker Symbol Sign
 P/N 9000-99717 36" Flag Man Ahead Sign
 P/N 9000-99716 36" Utility Work Ahead Sign

P/N 9000-99719 48" Changeable Right/Left Lane Sign
 P/N 9000-24432 48" Utility Work Ahead Sign
 P/N 9000-99713 48" Men Working Sign
 P/N 9000-99714 48" Flag Man Ahead Sign
 P/N 9000-99923 48" Worker Symbol Sign

Wind-Resistant Dynaflex Sign Stand



- NCHRP 350 compatibility- crash test results available
- Complies with MUTCD standards
- Features wind-relieving dual torsion spring system
- Ease of use with fast kick release system, locking legs into place when fully extended
- Displays 36" and 48" signs using ScrewLock™ attachment
- All aluminum and steel construction
- Telescoping aluminum legs with two position height adjustment and anti-skid foot pads
- Full extension length: 51" (1295 mm) each leg
- Open footprint: 92" x 57-1/2" (2337 mm X 1461 mm)
- Wind-relieving, dual torsion spring system - withstands winds up to 65 mph
- Minimum height from the ground to bottom of panel: 12" (305mm)

P/N 9702-84417 Fits Wind-Resistant Roll-Up Signs

Dynaflex Sign Stand



- NCHRP-350 approved
- Complies with MUTCD standards
- Dual torsion springs
- Hold 36" and 48" signs in a variety of materials and configurations
- All aluminum and steel construction
- Features telescoping aluminum legs with two position height adjustment and anti-skid foot pads
- Easy to use with kick release system

for legs and quick locking sign holders

- Minimum height from ground to bottom of panel: 12"

P/N 9000-24427 Fits Fold and Roll Signs

Tripod Aluminum Sign Stand



- NCHRP-350 test level 2 accepted with roll-up sign
- Made of durable 1" round O.D. galvanized tubing
- No sharp edges
- Displays 36" or 48" roll up or rigid signs 12" off ground
- Design allows for quick, easy set-up

P/N 9701-20725

Twin Flex Dual Spring Sign Stand



- Complies with MUTCD standards
- Features two vertical coil springs
- Displays 36" and 48" reflective signs
- All aluminum and steel construction
- Features telescoping aluminum legs with two position height adjustment and anti-skid foot pads
- Quick setup and tear down with kick release system for leg deployment
- Minimum height from ground to bottom of panel: 12"

P/N 9700-20598 Twin Flex Dual Spring Sign Stand

Uniflex Single Spring Sign Stand



- NCHRP-350 approved
- Complies with MUTCD standards
- Features versatile, compact single-coil spring
- Displays 36" and 48" reflective signs using ScrewLock™ attachment
- All aluminum and steel construction
- Features telescoping aluminum legs with two position height adjustment, anti-skid foot pads
- 12" minimum height from ground to panel edge

P/N 9700-20643 Uniflex Sign Stand

CROSSBRACE ASSEMBLIES:

P/N 9000-24406 36" Crossbrace Assembly
 P/N 9000-24407 48" Crossbrace Assembly

The Stacker™ Sign Stand



- Low profile rubber base sign stand is ideal for limited storage or display areas
- Recessed trim molded into rubber base allows for firm, compact storage
- Two molded carrying handles for easy transport
- 3" tall x 20" wide x 28" long
- Pocket panel holder clamps roll-up sign to stand utilizing plastic pocket on sign panel
- Mast folds down into rubber base via kick release for storage

P/N 9701-12377 Pocket Panel Holder

SAFETY EQUIPMENT

USA: 1-877-77-GO ALTEC
 (1-877-462-5832)

www.alteconnect.com



TRAFFIC SAFETY EQUIPMENT

SAFETY EQUIPMENT

USA: 1-877-GO ALTEC
(1-877-462-5832)

www.alteconnect.com

FoxFire Logger Lite



- Provides a convenient way of marking the end of a load
- Includes FoxFire Lite, metal utility bracket, and custom T-handled tool
- Other sizes and styles available

P/N 9701-41791 FFL-Amber
P/N 9701-41792 FFL-Red

Pole Wrap for Hold Card



- Wraps around pole with Velcro®
- 360° visibility
- Reflective striping for night time visibility
- Pocket for hold card 6" W x 9" L hold card holder that wraps around the pole and is secured

- with Velcro®
- The warning is "Worker On Line"
- There is a clear pouch on the wrap to hold your card

P/N 9701-34642 45" Long Class 2 Pole or Below
P/N 9701-34643 1180-57 57" Long Class 3 or 4 Pole

ALTEC SUPPLY Pole Wrap for Hold Card



- Class 2 Pole or Below
- Wraps around pole with Velcro®
- 360° Visibility
- Clear Pocket for hold card

- Warning is "WORKER ON LINE"
- P/N 9703-33786 6" Wide x 45" Long
P/N 9703-33787 6" Wide x 57" Long

Safety Cone Holders



Fixed style (left)
Horizontal style (above)

- Provides easy access to cones
- Both fixed and fold down style available

Bumper Mount Fold-Down Style:
P/N 9000-80024 Fixed - 12" x 12" x 19 3/4" Tall
P/N 660-21028 Fixed - 14" x 18" x 26" Tall
P/N 3172-01205 Fixed - 14" x 14" x 27.5"
P/N 9700-32039 Horizontal

VizCon TurboFlare



- 20 Ultra-Bright LED's-Red
- Emits light at 20-25° to oncoming traffic for maximum nighttime visibility
- 360° Rotation provides visibility to oncoming traffic from all directions: 190 rotations per minute
- Visibility: 1/2 mile -1 mile
- Impact resistant polycarbonate withstands tire impacts and vehicle rollovers
- 2" total height x 8" diameter
- Weather resistant, shock resistant and vibration resistant
- Powered by (4) AA batteries
- 60-80 hour battery life
- Provides years of safe and effective operation
- No hazardous chemicals-Environmentally safe
- Eliminate skin burns and damage to uniforms and clothing
- No clean-up necessary
- Reusable day after day



P/N 9702-72495 TF-3TP-3R-AA 3 Unit Pail, Red
P/N 9702-72507 TF-4TP-4R-AA 4 Unit Pail, Red
P/N 9702-72509 TF-5TP-5R-AA 5 Unit Pail, Red
P/N 9702-72510 TF-8TP-8R-AA 8 Unit Case, Red
P/N 9000-96235 TF-10TP-10R-AA 10 Unit Case, Red

Safety Cones



- Rugged, brightly colored safety cones
- Designed for many years of outside use
- Cones are constructed of day-glow red/orange PVC with two reflective collars
- 18", 28", and 36" tall cones available

P/N 9000-00215 18" Cone Base 11" x 11"
P/N 9000-00216 28" Cone Base 14" x 14"
P/N 9000-30042 36" Cone Base 14.5" x 14.5"

18" & 28" Pack N' Pop Cones & Tote



- 13.5" x 13.5" x 8" plastic tote holds 4 cones
- Durable, bright orange, flexible nylon
- Rubber base grips the road for stability
- Meets MUTCD standards
- Collapses flat for easy storage
- Internal light endures over 100,000 flashes or 36 hours of steady burn

P/N 9700-89530 Qty of 4 - 18" Cones/Nylon Bag Set
P/N 9700-89527 Qty of 4 - 28" Cones/Nylon Bag Set

Emergency Warning Triangle Kit



- Weighted base anchors the triangles
- No tools required for set-up
- Kit includes 3 triangles that fold flat
- Includes a compact plastic storage container

P/N 660-21045 James King Co. 1005

TRUCK SAFETY EQUIPMENT

Wooden Outrigger Pads



- Adds stability and safety in soft grass, acting as a “shoe” for the outrigger, reducing pits, depressions, cracks, and other disruptions of surfaces to pavement and grass
- Lightweight, compact, and easily stored on truck

P/N 0692-93117 Wood 15”x 24”x3”

P/N 0692-93119 Wood 18”x 18”x3”

P/N 0692-93118 Wood 24”x 24”x3”

Composite Outrigger Pads



- Lightweight, non-conductive, and moisture resistant
- Stronger than the average wood, plywood, or cast metal outrigger pads
- Pad will return to its original shape once load is removed
- Resistant to chemicals, solvents, oils

P/N 0692-93078 (“A”) Composite 22” x 24” x 1”

P/N 9000-93078 (“B”) Composite 22” x 22” x 1” (Non-Skid)

P/N 9703-24726 18” x 18” x 1”

Aluminum Outrigger Pads



- Aluminum/magnesium does not waterlog, crack, or splinter like wooden pads
- Strong, yet lightweight
- Engineered design prevents slipping and sinking

P/N 0692-93099 Aluminum 14”x 26”x2 1/2”

P/N 0692-93055 Aluminum 18”x 18”x2 1/2”

P/N 0692-93081 Aluminum 24”x 24”x3”

Composite Outrigger Pads for Altec Backyard Digger Derrick



- Lightweight, non-conductive, moisture-resistant
- Stronger than the average wood, plywood, or cast metal outrigger pads
- Pad will return to its original shape once load is removed
- Resistant to chemicals, solvents, and oils

P/N 9701-09032 18” x 18”

Anti-Skid Surfacing Material



- The sure traction provided by this anti-skid tape prevents slipping and falling on wet or slick floors or stairs
- Tape surface coated with thousands of particles of durable aluminum oxide grit
- Rugged tape is an adhesive-backed plastic tape material
- Easy installation - just peel off protective liner and press in place
- No extra edge sealing is necessary

P/N 0660-60009 12” wide; 60’ Roll

P/N 0660-60011 6” wide; 60’ Roll

P/N 0099-00043 1 Gallon Grey Non-Slip

P/N 0099-00054 1 Gallon Black Non-Slip



 **Altec
Supply**

SAFETY EQUIPMENT

**USA: 1-877-GO ALTEC
(1-877-462-5832)**

www.alteconnect.com

TRUCK SAFETY - BARRICADE EQUIPMENT

SAFETY EQUIPMENT

USA: 1-877-GO ALTEC
(1-877-462-5832)

www.alteconnect.com

A.B. Chance / Hubbell Truck Safety Barricade Kit

- This kit keeps workers and onlookers away from the truck when the truck is being used in proximity to energized conductors
- Six rods, of bright orange Epoxirod®, provide a 6' air space around the entire perimeter of the truck
- The safety barricade also includes six pieces of 3" long steel tubing (to be welded to truck by the customer) to hold the barricade rods, 150' of yellow rope and a canvas storage bag
- The entire kit requires less storage than traffic cones and can be quickly installed and removed at each job site

P/N 9700-28250 Hubbell T3060006



Hastings Truck Safety Barricade Kit

- Barricade can be installed, positioned, or raised, and removed in minutes. Just drop in place in pre-located permanently attached steel brackets
- Fiberglass arm is easily positioned to adjust barricade for proper height above the ground and to compensate for parking on uneven terrain
- Design allows fiberglass arm to be quickly located in eight different positions
- Arm can be moved to "vertical travel position" when movement of truck for a short distance is required
- All metal components (except steel adapters attached to truck) are stainless steel or aluminum, to reduce corrosion problems from salt atmosphere and winter operations



P/N 8140-00372 6795 Truck Safety Barrier Kit with 4' Arms
 P/N 9000-99601 6796 Truck Safety Barrier Kit with 6' Arms
 P/N 8140-00371 6798-1 Universal weld on adapter
 P/N 8140-00373 6795-1 4' Fiberglass Arm with Bracket
 P/N 9000-99602 6496-1 6' Fiberglass Arm with Bracket

Hastings Truck Barricade Kit for ALTEC Units

- **Made exclusively for Altec Units**
- Barrier can be installed, positioned, or raised for moving truck and removed in minutes. Just drop in place in pre-located permanently attached steel brackets
- Fiberglass arm is easily positioned to adjust barricade for proper height above the ground and to compensate for parking on uneven terrain
- Arm can be moved to vertical travel position when short distance movement of a truck is required
- All metal components (except for steel adapters for attaching to trucks) are stainless steel or aluminum, to reduce corrosion problems from salt atmosphere and winter operations
- **Unique design of sector allows fiberglass arm to be quickly locked in eight different positions from 30 degrees above horizontal to 22 1/2" below horizontal in 7 1/2 degree increments through the use of a stainless steel quick release pin**

P/N 9702-91325 Made Exclusively For Altec Units

Includes: (4) 9701-18724 EX3-729 arms
 (2) 7160-30542 6800 Danger Signs - Red,
 (1) 7160-30546 3649 150' - 1/4" Polypropylene Rope (Yellow)



Hastings Truck Barricade Arm

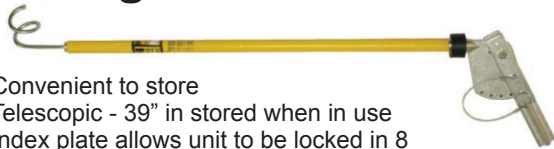

- Convenient to store
- Telescopic - 39" in stored when in use
- Index plate allows unit to be locked in 8 different positions
- Features rubber cushion base that helps prevent breakage in high traffic areas

P/N 7160-30543 6929

Hastings Sliding Barricade Bar



- 51" to 85"
- Telescopic barricade
- High visibility yellow and black
- Ideal visual barricade

P/N 9701-06915 6850



MK8 EVOLUTION™

THE STRONGEST INDUSTRIAL SAFETY HELMET IN THE WORLD

The MK8 Evolution™ meets the ANSI Z89.1-2009 standard for Type II impact protection. However, it is also the only industrial safety helmet in the world at this time meeting and exceeding the new, tougher European standard EN14052, the biggest advance in industrial head protection in over 45 years. But most importantly, MK8 Evolution™ provides protection from SIDE IMPACTS and SIDE PENETRATION to the same level as ANSI Z89.1 Type I testing, with almost 20 times the coverage area.

- Meets ANSI/ISEA Z89.1-2009, Type II, Class E requirements
- Offers Side (Lateral) Impact Protection which reduces the force of impact resulting from a blow which may be received off center as well as to the top of the head
- Also offers Side Penetration Protection in addition to crown penetration
- Expanded Polystyrene (EPS) Impact Liner helps absorb the forces of impact
- Deluxe Polyester Textile Strap Suspension with microfiber crown pad webbing
- Wheel Ratchet Adjustment allows user to easily adjust fit while wearing
- High-Density Polyethylene (HDPE) Shell and Universal Accessory Slots

P/N 9704-96985 280-AHS150-10 White (Min. Order Qty of 8)
 P/N 9704-96986 280-AHS150-10 White with Altec Logo

MK8 Evolution™ Linesman Hard Hat

ALL the Features of the MK8 Evolution Plus a 4-Point Chin Strap

P/N 9704-96987 280-AHS240-10 White (Min. Order Qty of 8)
 P/N 9704-96988 280-AHS240-10 White with Altec Logo



EVOLUTION™ 6100 Hard Hats



Full Brim Style

- High-Density Polyethylene (HDPE) shell with a full brim providing additional protection against sun, glare, rain and falling debris
- Extended back brim helps protect neck and ears from the sun's UV rays, as well as a run-off for rain and snow...short front brim shades the face while allowing excellent visibility
- Brim includes finger grips on front and rear, as well as a textured underside to reduce reflection/glare
- EasyJust™ slip ratchet is simple to adjust and an improved alternative to the traditional pin-lock system
- 6-Point suspension system with polyester textile straps offers unrivalled comfort without compromising performance
- Unique "3D Adjustment" provides a precise fit using harness depth settings... unlike any other hard hat on the US market today

- Evolution Wheel Ratchet is easy to use and creates a firm comfortable fit
- Chamlon™ sweatband for maximum sweat absorption
- Vented versions are available to reduce inside helmet temperatures... ANSI Class C
- Universal slots to fit various accessories
- Packed ready-to-wear with no installation of the suspension required
- Meets ANSI/ISEA Z89.1-2009, Type I, Class E requirements

Full Brim Style

P/N 9704-96989 280-EV6141-10 White, Slip Ratchet
 P/N 9704-96990 280-EV6141V-10 White, Slip Ratchet; Vented
 P/N 9704-96991 280-EV6161-10 White, Wheel Ratchet
 P/N 9704-96992 280-EV6161V-10 White, Wheel Ratchet; Vented

Cap Style

P/N 9704-96993 280-EV6121-10 White, Slip Ratchet
 P/N 9704-96994 280-EV6121V-10 White, Slip Ratchet; Vented
 P/N 9704-96995 280-EV6151-10 White, Wheel Ratchet
 P/N 9704-96996 280-EV6151V-10 White, Wheel Ratchet; Vented
 P/N 9704-97783 280-EV6151-10-ALTEC White, Wheel Ratchet; Vented, Altec Logo



Cap Style

SAFETY EQUIPMENT

USA: 1-877-GO ALTEC
 (1-877-462-5832)

www.alteconnect.com

PERSONAL SAFETY EQUIPMENT & ACCESSORIES

SAFETY EQUIPMENT

USA: 1-877-GO ALTEC
(1-877-462-5832)

www.alteconnect.com

V-Gard Protective Cap



- Ratchet suspension adjusts size quickly and easily
- Nylon crown suspension straps fit comfortably
- Lightweight and balanced for all day wear

P/N 9000-47538 White
P/N 9000-75360 Yellow
P/N 9000-00182 White with Altec Logo

Hard Hat Seat Rack

- Convenient hard hat holder for use on the back of a vehicle seat

P/N 9000-00194

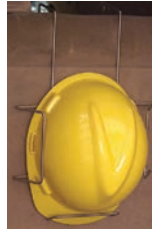

Sun Shields



- These sun shields extend the brim of the hard hat all the way around to help protect the wearer's ears and neck from the sun's rays
- Made of polyurethane
- Front portion is Lexan with a smoke tint

P/N 9700-04588 For the V-Gard® Protective Cap
P/N 9700-04589 For the V-Gard® Protective Hat

Full Face Knitted Tube Liner *



- 100% polyester
- Fits snugly over hard hat and blocks wind tunneling in the crown
- Traps warm air to keep head, face, nose, and ears warm
- Can be folded up outside of hard hat during breaks
- Does not have ear barriers, reflective strip, gap eliminator, or warming pack pockets

P/N 9701-72711 LK 810 Red*

* This is NOT an FR Product

Hard Hat Warming Tube Liners



- 100% Polyester
 - Fits snugly over hard hat
 - Blocks wind tunneling inside the crown
 - Traps warmth to keep head and ears warm
 - Folds up on the outside of a hardhat, when not needed during breaks
 - Flame resistant
- P/N 9000-00800

V-Gard Protective Hat



- Brim around entire cap helps keep rain and sun off wearer's neck and ears
- Short front brim allows unimpeded upward vision
- Ratchet suspension adjusts size quickly and easily
- Nylon crown suspension straps fit comfortably
- Lightweight and balanced for all day wear
- Available in white, yellow, and orange

P/N 9000-75369 White
P/N 9000-55366 Yellow
P/N 9000-21292 Orange

Cowboy Style Hard Hat



- Stylish and comfortable
- Meets ANSI Z89.1-2003, Type 1, Class E, G, & C
- Extra wide brim provides more UV protection than standard or full brim hard hats
- Fully adjustable 6-point ratchet suspension

P/N 9000-22220 White
P/N 9000-22221 Black
P/N 9000-22222 Tan
P/N 9000-22223 Gray

Shoulder Length Winter Liner



- P/N 9000-00193 features a 100% cotton twill shell and is lined with a heavyweight flame-resistant polyester fleece
- All materials (cotton twill, polyester fleece, and binding) are flame retardant until washed
- Features pockets near ears for warm packs

P/N 9000-00193 Blue (Flame Resistant)
P/N 9700-05979 Grey (NOT Flame Resistant)

Knitted Tube Liner FLAME RESISTANT



- 100% polyester; flame resistant
- Fits snugly over hard hat and blocks wind tunneling in the crown
- Traps warm air to keep head and ears warm
- Easily folds up on outside of hard hat
- Does not have ear barriers, reflective strip, gap eliminator, or warming pack pockets

P/N 9701-72709 RK 800FR Black

PERSONAL SAFETY EQUIPMENT & ACCESSORIES

Cooling Hard Hat Inserts



Hard Hat Pad
P/N 9000-99421



Hard Hat Pad
w/ Neck shade
P/N 9000-99422



CottonTerry
Hard Hat Liner
P/N 9000-99419



Cotton Terry
Hard Hat Band
P/N 9000-99418

- These liners are made with napped cotton terry, but also have cooling crystals encased within
- Crystals work in combination with the evaporation process
- When worn against the head or neck they create a cooling sensation that is passed to pulse points and carried throughout the body

Cooling Vest



P/N 9000-99416 Regular
P/N 9000-99417 X-Large

- Ideal for linemen, heavy equipment operators, or anyone working in a warm indoor or outdoor environment
- Designed to keep the user cool and alert
- Cooling crystals work in combination with the evaporation process
- These vests are also reversible for continuous cooling
- Soak in cold water for 10-20 minutes
- Reusable thousands of times
- Works without freezing or ice

Cooling Bandana



- The cooling crystals encased within the 100% cotton fabric absorb and hold up to 1,000 times their weight in cool, refreshing water
 - The crystals work in combination with the evaporation process
 - When worn against the head, neck, or body, cooling sensations are passed to pulse points and carried throughout the body
 - Soak in cold water for 10 - 20 minutes; stays hydrated for several days and is reusable thousands of times
- P/N 9000-99420

Hard Hat Sweatband



- Install in an instant, no fumbling with snaps
 - Reversible and machine washable
 - Made from single cotton terry plus an extra foam middle layer for absorbency and comfort
 - One size fits almost every hard hat
 - Lightweight and very absorbent
- Keeps perspiration off face
- P/N 9000-99415

Terry Hard Hat Inserts

- Super absorbent double napped cotton terry
- Double layer of terry and a layer of foam around the rim catch more perspiration
- P/N 9000-99424 (right) blocks sun and keeps perspiration off face and neck

P/N 9000-99424



Nemesis™ Safety Glasses



- Delivers 99.9% protection from harmful UV rays
 - Features soft-touch temples for added comfort
 - Offers unobstructed sight lines, so you can see what's coming at you
- Wrap-around lens constructed of lightweight, scratch-resistant polycarbonate delivers advanced visual acuity and protection
 - Meets the ANSI Z87.1 standard for optical clarity and impact resistance

P/N 9000-00191 Clear Lens

P/N 9000-00192 Blue Mirror Lens

SAFETY EQUIPMENT

USA: 1-877-GO ALTEC
(1-877-462-5832)

www.alteconnect.com

MISCELLANEOUS SAFETY EQUIPMENT

IGLOO Heat Stress Coolers

In response to the increasing concern about heat-related illness, Igloo Corp. introduces the new Igloo Heat Stress Solution water coolers. Printed bilingually in bright red lettering on the iconic yellow & red beverage coolers are tips to prevent heat illness.

- Now with XL Spigot!
- Cooler maintains ice for 3 days at 90°F!
- Drinking Water Imprint Meets OSHA Labeling Requirements For Water Used On Jobsites
- High-visibility Safety Yellow color
- UV inhibitors protect against sun damage
- Pressure-fit lid won't trap dirt/mold
- Reinforced handles for strength and product longevity
- Recessed and angled drip-resistant spigot for easy dispensing
- Keeper cord affixes lid to cooler for cleanliness and loss prevention
- Integrated handle-lid can be locked to side handles for added security and assurance of cleanliness
- Front push-button spigot is easy to access when wearing gloves on a worksite

P/N 0685-00015 48513 5 Gallon

P/N 9000-00213 48514 10 Gallon



Igloo Water Coolers

- Sturdy plastic water coolers help keep plenty of fresh drinking water on hand at the job site
- Constructed of durable plastic that won't rust or fade in direct sunlight
- A sanitary white liner is surrounded by insulation, which helps keep beverages cool
- Wide-mouth, pressure fit lid with a mold-in contour handle for easy filling
- "Drinking water" imprint meets OSHA requirements

P/N 685-00012 2 Gallon

P/N 685-00025 3 Gallon



AMERICAN POLYWATER CLEANERS, DEGREASERS, & MAINTENANCE

HP™ Multi-purpose Cleaner/Degreaser



- Specially formulated solvent for multi-purpose industrial, maintenance cleaning
- Effectively cleans industrial grimes, greases, lubrication fluids, silicone, tars, adhesives, and fluxes
- Evaporates without residue

and is essentially non-conductive

- Cleans transformer oils, corrosion inhibitor compounds, silicone grease, semi-conducting paints, etc.
- For all electrical and communications cleaning needs
- Contains no CFC's, HCFC's, chlorinated solvents, perchloroethylene, or other ozone-depleting solvents
- Harmless to most plastics, including polycarbonate, ABS and polyethylene; no residue, non-corrosive, non-freezing, non-staining to metals

P/N 9701-76851 HP-16LF 16 fluid oz. bottle; flip top

P/N 9701-76852 HP-35LF 1 quart bottle; flip top

P/N 9701-76855 HPY-12 10.5 oz. Aerosol Can

P/N 9701-76847 ST-R Trigger sprayer for bottles

FD™ Electrical Contact Cleaner



- Multi-purpose industrial and maintenance cleaner evaporates quickly, without residue
- Replaces ozone-depleting CFC's, trichloroethane, HCFC's, perchloroethylene, and other carcinogenic chlorinated solvents
- Effectively dissolves industrial grimes, greases, lubrication fluids, silicone, tars, adhesives, and fluxes

- Suitable for use in electrical maintenance as a replacement for 1,1,1-trichloroethane

- Quickly cleans transformer oils, corrosion inhibitor compounds, silicone grease, semi-conducting paints, etc.

- No chlorinated solvents; non-conductive, non-staining

P/N 9701-76848 FD-16LF 16 Fluid oz. Bottle; Flip Top

P/N 9701-76849 FD-35LF 1 Quart Bottle; Flip Top

P/N 9701-76850 FD-9 9 oz. Aerosol Can

P/N 9701-76847 ST-R Trigger Sprayer for Bottles

S-1™ Hot Stick Cleaner & Water Repellent Wipes



- Dual action - cleans, applies water repellent
- Does not remove or adversely affect gloss coat
- No "build-up" over time
- Evaporates quickly
- Removes grease, dirt, and grime
- Meets IEEE maintenance recommendations
- Convenient, pre-saturated, lint-free wipe

• Prevents continuous water film on stick in wet weather
P/N 9000-96200 S-1 Hot Stick Cleaner/Water Repellent Wipes

American Polywater Grime-Away™ Wipes



Quickly Removes:

- PVC Pipe Cement
- Transformer Oils
- Cable Gels
- Silicone Greases
- Oxide Inhibitors
- Dirt/Soil
- Adhesives
- Caulk
- Lubricants
- HDD Pipe Thread
- Grease
- Tar/Asphalt

- Heavy-duty towelettes pre-moistened with a multi-purpose cleaning solution
- Feature a textured side to quickly remove greases, dirt, and grime from items such as tools, transformers, work surfaces, equipment, service vehicles, machinery, etc. and a softer side that moisturizes and is gentle on skin

P/N 9000-96202 HTC-D72
Container of 72

Note: Grime-Away™ is compatible with insulating rubber gloves.



Rubber Goods Cleaner



- A specially formulated water-based cleaner for removing dirt, grease, and grime from lineman's gloves, sleeves, jumper cables, and other rubber goods

P/N 9700-63375 RBG-35LR One quart bottle with sprayer
P/N 9701-29493 RBG-D72 Container with 72 Towels

W-1™ Wax & Buff Wipes for Live-Line Tool Maintenance

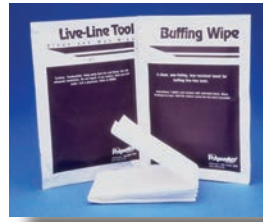

- Convenient, Wax-Saturated, Lint-Free Wipe
- Dual Action Tandem Pack Includes Dry Buffing Towel
- Superior Quality, Fast-Hazing Fiberglass Wax
- Suitable for Rubber and Porcelain Materials Too
- Easy to Apply

- Does Not Remove or Adversely Affect Gel Coat
- Leaves Non-Conductive Water Repellent Coating
- Prevents Continuous Water Film on Stick in Wet Weather
- Designed for One Time Use and Easy Disposal
- Meets IEEE Maintenance Recommendations

P/N 9706-41164 W-1 (72) Wax-Saturated Wipes with Dry Buffing Towel

P/N 9702-16393 W-16 (12) 16 oz. Fast-Hazing Fiberglass Wax

Boom™ Prewash Wipes for Electrical Safety



- BOOM™ Prewash Wipes are cleaner-saturated towels that clean grease, tar, creosote, salt spray, hydraulic fluid, pine pitch, and road debris off fiberglass boom arms
- Water soluble; washes off during subsequent water rinsing
- Boom™ Wipes do not

adversely affect the gel coat on booms

P/N 9700-84328 B-1 Individual 24" x 24" Wipes

P/N 9000-96201 B-D72 Container of 72

AMERICAN POLYWATER CORPORATION is committed to providing safe, effective cleaners and protective waxes that will maintain the safety and life of your fleet.

Removal of hydraulic fluid, pine pitch, road tar, and other contaminants that build up during the normal exposure of the boom is vital to maintaining the dielectric properties of your boom. When residue builds on the boom, water sheets out rather than beading up and running off. This pooling or sheeting of water on dirty booms can keep the booms from meeting dielectric standards and potentially pose a hazard in the field.

Common degreasers or solvents can actually harm and strip the gel coat on the boom causing weak or soft spots. **AMERICAN POLYWATER** cleaners do **NOT** contain abrasives and do **NOT** leave a residue. Others, like acetone, xylene, and toluene, can cause permanent damage if left in contact with the surface for too long a period; these solvents are flammable, among other hazards. **AMERICAN POLYWATER** products assist you in **protecting** your investments and are a **safe** alternative.

You can be assured that your fleet will be well-cared for with the use of **AMERICAN POLYWATER** maintenance products.

ZOLL AED Plus

SAFETY EQUIPMENT

USA: 1-877-GO ALTEC
(1-877-462-5832)

www.alteccconnect.com

The ZOLL® AED Plus® provides the best support for resuscitating a victim of sudden cardiac arrest. The AED Plus is the first and only automated external defibrillator (AED) with Real CPR Help® technology for depth and rate of chest compressions during CPR.

ZOLL® AED Plus Semiautomatic Packages:

P/N 9706-40270 8000-004000-01

AED Plus Package with Medical Prescription

Includes semiautomatic AED Plus, one set of adult electrodes (CPR-D-padz), sleeve of batteries, carry case, and medical prescription

P/N 9706-40771 8000-004003-01

AED Plus Package with PlusTrac Professional¹

Includes semiautomatic AED Plus, one set of adult electrodes (CPR-D-padz), sleeve of batteries, carry case, and one-year of AED program management

P/N 9706-40772 8000-004004-01

AED Plus Package with PlusTrac Professional⁵

Includes semiautomatic AED Plus, one set of adult electrodes (CPR-D-padz), sleeve of batteries, carry case, and five years of AED program management

ZOLL AED Plus Fully Automatic Packages:

P/N 9705-30060 8000-004007-01

Fully Automatic AED Plus Package with Medical Prescription

Includes fully automatic AED Plus, one set of adult electrodes (CPR-D-padz), sleeve of batteries, carry case, and medical prescription

Fully Automatic Package is available as P/N 8000-004000-01

P/N 9706-40773 8000-004010-01

Fully Automatic AED Plus Package with PlusTrac Professional¹

Includes fully automatic AED Plus, one set of adult electrodes (CPR-D-padz), sleeve of batteries, carry case, and one-year of AED program management

P/N 9706-40774 8000-004011-01

Fully Automatic AED Plus Package with PlusTrac Professional⁵

Includes fully automatic AED Plus, one set of adult electrodes (CPR-D-padz), sleeve of batteries, carry case, and five years of AED Program Management

ZOLL AED Plus® Accessories:

P/N 9706-40775 8900-0800-01 CPR-D-padz

One piece adult electrode pad with Real CPR Help®. Supplied with gloves, barrier mask, scissors, razor, wet wipe and dry wipe. Five (5) year shelf-life

P/N 9706-40776 8900-0810-01 Pedi-padz® II - Pediatric Multi-Function Electrodes

Designed for use with the AED Plus. The AED recognizes when pedi-padz II are connected and automatically proceeds with a pediatric ECG and adjusts energy to pediatric levels. Twenty four (24) month shelf-life. One pair.

P/N 9706-40777 8000-0807-01

Type 123A Lithium Batteries, quantity of ten (10) with storage sleeve

P/N 9704-64025 8000-0855

Standard Metal Wall Cabinet

9" deep cabinet designed to hold AED Plus in a carry case with spare electrodes

P/N 9706-40778 8000-0825

AED Plus Sign Package - 3-D Wall Sign & Wall Sign (8½" x 11")

P/N 9706-20671 8000-0836-01

Small Pelican Case - Small waterproof hard case with cut-outs for AED Plus only. Its high-density foam provides total protection from the rigors of impact, vibration and shock.

P/N 9704-64021 8000-0837-01

Large Pelican Case



Fully Automatic Package



EMERGENCY EQUIPMENT

Fire Extinguishers for Electrical Equipment



- Dispense a precisely dispersed, rapidly evaporating liquid agent that is electrically non-conductive
- Does not cause thermoshock on sensitive electrical equipment
- Pressurized with argon
- The liquid agent is HydroChloroFluoroCarbon (blend B) for use in extinguishing class A, B, C type fires
- Ideal for extinguishing fires originating at or near delicate electronics and electrical equipment such as mobile units, computers, telephone switch gear, etc.

P/N 9000-99598 2.5 lbs.

P/N 9000-99599 5 lbs.

Hurt Man Rescue System



- Aerial rescue kit is ideal for lifting the hurt worker quickly and efficiently
- Pulleys are made of stainless steel with a 4-to-1 lifting advantage
- Designed to mount high to

raise a person wearing a harness further up to assist in the rescue

P/N 9000-99605

Utility Solutions BLUE STRIPE Rescue Hook

The Utility Solutions Rescue Hook is designed to remove an injured worker from a hazardous situation including confined spaces, on or near electrical gear, or in vaults. Meets or exceeds all applicable industry performance criteria including OSHA 1926.951(d)(1) and ASTM F-711.

The innovative design allows for the unit to ship as two separate components, resulting in substantial shipping savings without sacrificing strength or toughness.

9703-35346 USRH-006 6' Rescue Hook
9702-08581 USRH-008 8' Rescue Hook

Two Man First Aid Kit



- First Aid Kit carry case
- Flexi-cloth Knuckle Band-Aid 40/box
- Woven Adhesive Bandage 50/box
- 1/2" x 5 yds. Adhesive Tape
- 2" x 2" Gauze Pads 10/box
- 2" Roller Gauze
- Large Cold Pack
- 3-in-1 Ointment 5 each
- Alcohol Wipes 5 each
- Antiseptic Wipes 5 each

- 3" Compress
- Triangular Bandage
- Insect Sting Swabs 3/vial
- Iodine Swabs 3/vial
- Vinyl Gloves 2 pair/box
- Kit Scissors
- Kit Tweezers
- First Aid Handbook
- Burn Jel 6/box
- Ivy Block Lotion (6)
- Eye Wash 1 oz.

P/N 660-30002

Multi-Purpose Fire Extinguishers



- Designed to fight all common fires (Class ABC): wood, electrical, gas, oil, flammable liquids, paper and cloth
- Features easy-to-pull safety pin
- Capacities range from 2.5 lbs. to 10 lbs.
- Rust and impact resistant nylon handle
- Easy-to-read gauge tells when extinguisher is charged and ready for use
- Quick, clear directions for ease of use
- Includes vehicle mounting bracket

P/N 9702-33765 2.5 lbs.

P/N 0660-10001 5 lbs.

P/N 0660-10004 18 lbs.

High Elevation Self-Rescue System



- Designed for both self-rescue or rescuing someone else from elevated heights
- Descender will automatically stop the descent until the user compresses the handle, which allows a smooth, controlled descent

- A built-in, anti-panic safety feature will stop the descent if the user compresses the handle with excessive force
- The system includes retrofit rappelling straps that can be added to an existing harness for self-rescue

P/N 9000-99604

Vinyl Safety Labels



- High visibility lettering
- Heavy duty vinyl with peel-off backing to expose adhesive

P/N 9000-00201 "First Aid Kit Inside" Sign, 3" x 5"

P/N 9705-50832 "Fire Extinguisher Inside" Sign, 3" x 5"

P/N 9000-00200 "Fire Extinguisher" Sign, 17.495" Long



SAFETY EQUIPMENT

USA: 1-877-GO ALTEC
(1-877-462-5832)

www.alteconnect.com



CROSSFIRE[®]
Z87+ PROTECTIVE EYEWEAR

INNOVATIVE SOLUTIONS

FOR SAFETY EYEWEAR



SAFETY EQUIPMENT

USA: 1-877-GO ALTEC
(1-877-462-5832)

www.alteconnect.com

99.9% Protection From Harmful UVA And UVB Rays
100% Visually Correct De-Centered Lenses
2.2 Mm Panlite Brand Polycarbonate Lens Material
Lens Quality And Performance Meet And Exceed Ansi Z87-1-2003 High Impact Standards



ES4 Model # 211125
Frame: Crystal Brown
Lens: HD Brown Flash Mirror
P/N 9703-59518



ES4 Model # 2123
Frame: Shiny Black
Lens: Silver Mirror
P/N 9703-59520



ES5 Model # 2961
Frame: Pearl Black
Lens: Smoke
P/N 9703-59521



ES5 Model # 29117
Frame: Crystal Brown
Lens: HD Brown Flash Mirror
P/N 9703-59527



Infinity Model # 2812
Frame: Black/Burnt Orange
Lens: Gold Mirror
P/N 9703-59534



Infinity Model # 2117
Frame: Crystal Brown
Lens: HD Brown Flash Mirror
P/N 9703-12224



Diamondback Model # 2761AF
Frame: Shiny Black
Lens: Smoke Anti-Fog
P/N 9702-78540



ES4 Model # 21427
Frame: Crystal Black
Lens: Silver Mirror Polarized
P/N 9703-50249



FIT - FUNCTION - STYLE

Crossfire Safety Eyewear is an industry leader in designing and manufacturing ANSI Z87 2010 certified safety eyewear. Our approach to design affords the end user a seamless link between the latest in style and cutting edge technology. We provide safety eyewear and foam lined styles that are directly aligned with the needs of our military, police, industrial workforce, and extreme sporting conditions.



Sniper Model # 9117
Frame: Crystal Brown
Lens: HD Brown Flash Mirror
P/N 9703-59539



Sniper Model # 921
Frame: Matte Black
Lens: Smoke
P/N 9703-59544



Concept Model # 821AF
Frame: Matte Black
Lens: Smoke Anti-Fog
P/N 9703-59546



Concept Model # 844AF
Frame: Crystal Black
Lens: Clear Anti-Fog
P/N 9703-59548



Cobra Model # 1541
Frame: Crystal Black
Lens: Smoke
P/N 9703-59552



Core Model # 18146
Frame: Woodland Brown Camo
Lens: HD Brown
P/N 9703-59554



RPG Model # 23233
Frame: Shiny Black/Pearl Red
Lens: Silver Mirror
P/N 9703-59560



RPG Model # 23226
Frame: Matte Black
Lens: HD Blue Mirror Polarized
P/N 9703-12227



KP6 Model # 3469
Frame: Shiny Black
Lens: Red Mirror
P/N 9702-78539



MP7 Model # 2461AF
Frame: Shiny Black
Lens: Smoke Anti-Fog
P/N 9703-59562



MP7 Model # 2444AF
Frame: Crystal Black
Lens: Clear Anti-Fog
P/N 9703-59565



MP7 Model # 24426
Frame: Crystal Black
Lens: Blue Green Polarized
P/N 9703-54254

SAFETY EQUIPMENT

**USA: 1-877-GO ALTEC
(1-877-462-5832)**

www.alteconnect.com



INNOVATIVE SOLUTIONS FOR SAFETY EYEWEAR

SAFETY EQUIPMENT

**USA: 1-877-GO ALTEC
(1-877-462-5832)**

www.alteconnect.com

Crossfire Safety Eyewear is an industry leader in designing and manufacturing ANSI Z87 2010 certified safety eyewear. Our approach to design affords the end user a seamless link between the latest in style and cutting edge technology.



AR3 Model # 16428
Frame: Crystal Black
Lens: Super Dark Smoke
P/N 9704-38445



AR3 Model # 161129
Frame: Crystal Brown
Lens: Super Dark Brown
P/N 9704-38457



Infinity Model # 241
Frame: Crystal Black
Lens: Smoke
P/N 9703-89013



ES4 Model # 21427
Frame: Crystal Black
Lens: Polarized Silver Mirror
P/N 9703-50249



Infinity Model # 2117
Frame: Crystal Brown
Lens: HD Brown Flash Mirror
P/N 9703-12224



Cobra Model # 1541
Frame: Crystal Black
Lens: Smoke
P/N 9703-59552



Diamond-Back Model # 2761AF
Frame: Matte Black
Lens: Anti-Fog Smoke
P/N 9702-78540



Cobra Model # 1528
Frame: Matte Black
Lens: Red Mirror
P/N 9703-76106



MP7 Model # 24426
Frame: Crystal Black
Lens: Blue Green Polarized
P/N 9703-54254



Infinity Model # 21126
Frame: Crystal Brown
Lens: HD Polarized Brown
P/N 9703-69602



Core Model # 18146
Frame: Woodland Brown Camo
Lens: HD Brown
P/N 9703-59554



Cobra Model # 1528
Frame: Matte Black
Lens: Red Mirror
P/N 9703-76106



ES5 Model # 29117
Frame: Crystal Brown
Lens: HD Brown Flash Mirror
P/N 9703-59527



Cobra Model # 15117
Frame: Crystal Brown
Lens: HD Brown Flash Mirror
P/N 9703-69604



Model # 2244
Frame: Pearl White
Lens: Clear
P/N 9703-88639



RPG Model # 23226
Frame: Matte Black
Lens: Polarized HD Blue Mirror
P/N 9703-12227



Model # 2243
Frame: Pearl White
Lens: Silver Mirror
P/N 9703-88640



Frame: Pearl Pink
P/N 9703-88642 22528 Dark Smoke Lens
P/N 9703-88645 2254 Clear Lens

EDGE

Safety Eyewear



**INDEPENDENTLY TESTED
AND COMPLIANT** 

SAFETY EQUIPMENT

NEW BRAZEAU DESIGNER SERIES!



9705-67788
XB116-A1



9705-67793
XB116-C1



9705-67791
XB116-A2



9705-67814
XB146-C2



9705-67797
XB116-P1



9705-67798
XB116-V1



9705-67818
XB146-P2



9705-67809
XB146-V2

**CALL 1-877-GO ALTEC
(1-877-462-5832)
FOR MORE DETAILS**

**USA: 1-877-GO ALTEC
(1-877-462-5832)**

www.alteccconnect.com

DECADES OF PROVEN EXPERIENCE...

BASHLIN CLIMBING EQUIPMENT

PERSONAL EQUIPMENT

USA: 1-877-GO ALTEC
(1-877-462-5832)

www.alteconnect.com



EZRIDER LINEMAN'S TOOLBELT

"Like Working in a Rocking Chair"

NEW EZ RIDER Lineman's Tool Belt is the right fit for "on-the-pole" comfort. The new ergonomic, contoured design allows the belt to be worn comfortably and correctly, without compromising safety; improperly wearing a tool belt (low and loose) to find comfort is eliminated. This belt

has unique "seat" built into the cushion that supports and gives never-seen-before comfort to your "seat". Simple in design and concept, and available with a nylon or leather cushion, this belt allows the lineman to take full advantage of the newer, advanced WPFRD products.

- Supports the lower abdomen, reducing leg discomfort and numbness
- Dramatically improves "on the pole" comfort
- Easily connects Pole Lariats, Pole Chokers, Cynch-Loks and similar WPFRDs

NYLON CUSHION

P/N 9704-96953	88UX4DMP-D18 (D18)
P/N 9704-96954	88UX4DMP-D19 (D19)
P/N 9704-96955	88UX4DMP-D20 (D20)
P/N 9704-96956	88UX4DMP-D21 (D21)
P/N 9704-96957	88UX4DMP-D22 (D22)
P/N 9704-96958	88UX4DMP-D23 (D23)
P/N 9704-96959	88UX4DMP-D24 (D24)
P/N 9704-96960	88UX4DMP-D25 (D25)
P/N 9704-96961	88UX4DMP-D26 (D26)
P/N 9704-96962	88UX4DMP-D27 (D27)
P/N 9704-96963	88UX4DMP-D28 (D28)

NYLON CUSHION with Bridge

P/N 9704-96964	88UXB4DMP-D18 (D18)
P/N 9704-96965	88UXB4DMP-D19 (D19)
P/N 9704-96966	88UXB4DMP-D20 (D20)
P/N 9704-96967	88UXB4DMP-D21 (D21)
P/N 9704-96968	88UXB4DMP-D22 (D22)
P/N 9704-96969	88UXB4DMP-D23 (D23)
P/N 9704-96970	88UXB4DMP-D24 (D24)
P/N 9704-96971	88UXB4DMP-D25 (D25)
P/N 9704-96972	88UXB4DMP-D26 (D26)
P/N 9704-96973	88UXB4DMP-D27 (D27)
P/N 9704-96974	88UXB4DMP-D28 (D28)

* Sizes D29-D32 are available but are non-cancellable & non-returnable



LEATHER CUSHION

P/N 9704-96975	88UX4DCC-D18 (D18)
P/N 9704-96976	88UX4DCC-D19 (D19)
P/N 9704-96977	88UX4DCC-D20 (D20)
P/N 9704-96978	88UX4DCC-D21 (D21)
P/N 9704-96979	88UX4DCC-D22 (D22)
P/N 9704-96980	88UX4DCC-D23 (D23)
P/N 9704-96981	88UX4DCC-D24 (D24)
P/N 9704-96982	88UX4DCC-D25 (D25)
P/N 9704-96983	88UX4DCC-D26 (D26)
P/N 9704-96984	88UX4DCC-D27 (D27)
P/N 9704-97098	88UX4DCC-D28 (D28)

4 Dee Ring Tool Belt



- Excellent for use with secondary lanyards and / or wood pole fall restricting devices
- Features an arc-resistant cushion that allows cooling and ventilation
- This soft material requires no break-in
- Hip-hugging design gives back support in a light weight belt.

Call 1-877-GO ALTEC for additional information on left-handed belts

BLACK REST-A-BACK

Q88GX4DMP	SIZE
P/N 9703-59846	D22
P/N 9703-55144	D23
P/N 9703-59853	D24
P/N 9703-59854	D25
P/N 9703-59856	D26

Other models and styles are available. Call 1-877-GO ALTEC for more information.

4019 Secondary Climbing Lanyards

- Features a newly designed snaphook and adjusters with a 90 degree twist at the cam connection
- A red wear indicator is standard on both lanyards
- 4019NX is double braided nylon-4019UX is Bashlin's exclusive neoprene coated climbing lanyard that needs no protective cover

P/N 9703-61919 4019NX-8
P/N 9703-61920 4019UX-8

Nylon Rope Adjustable Positioning Lanyard - 8 ft.
Uline Adjustable Positioning Lanyard - 8 ft.



P/N 9703-61919 4019NX-8

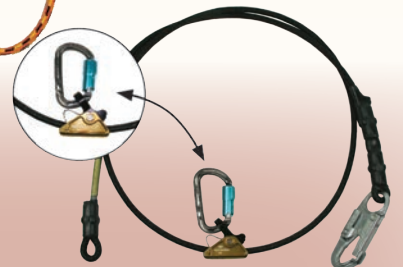

P/N 9703-61920 4019UX-8



QUALITY EQUIPMENT FOR PROFESSIONAL LINEWORKERS

PERSONAL EQUIPMENT

USA: 1-877-GO ALTEC
(1-877-462-5832)

www.alteconnect.com

Steel Pole Climbers

- Steel alloy adjustable climber
- Offset design
- Features a replaceable gaff, roomy ankle area, and a triangular strap ring
- P/N 9700-91316, P/N 9700-92828, P/N 9700-92829, and P/N 9700-92830 feature attached bottom, top straps

P/N 9700-91313 Bashlin BD16B-1N Bottom Straps Attached
 P/N 9700-91316 Bashlin BD16B-2N Bottom and Top Straps Attached
 P/N 9700-92828 Bashlin BD16B-3N Straps with Pad 110D
 P/N 9700-92829 Bashlin BD16B-4N Straps with Pad 130D
 P/N 9700-92830 Bashlin BD16B-5N Straps with Pad 140DS



Bashlin
BD16

Aluminum Alloy Pole Climbers

- Aluminum alloy offset climber features a replaceable, forged steel gaff
- Weigh 30% less than comparable steel climbers, reducing fatigue and adding climbing comfort
- P/N 9700-89473, P/N 9700-81109, P/N 9700-92831, and P/N 9700-92832 feature attached bottom, top straps

P/N 9700-18231 Bashlin BD14-1N Bottom Straps Attached
 P/N 9700-89473 Bashlin BD14-2N Bottom and Top Straps Attached
 P/N 9700-81109 Bashlin BD14-3N with Pad 110D
 P/N 9700-92831 Bashlin BD14-4N with Pad 130D
 P/N 9700-92832 Bashlin BD14-5N with Pad 140DS



Bashlin BD14

Aluminum Alloy Tree Climbers

- Designed for Tree Climbing and features a 2 1/2" gaff
- Reduces fatigue and adds climbing comfort
- Comparable steel climbers weigh 30% more
- Climbers come with bottom straps attached, top straps and P/N 9000-08142 pads
- Weighs 5.75 lbs.

P/N 9701-82523 Bashlin BD-14T-1N Bottom Straps Attached
 P/N 9701-82510 Bashlin BD-14T-2N Top-Bottom Straps Attached
 P/N 9000-93059 Bashlin BD-14T-5N Top-Bottom Straps 140DS Pads



Bashlin BD14T

Gaff Guards



- Made of leather and have a hook/loop attachment
- These guards protect the gaff and the climber

P/N 9000-20200 Bashlin #2

Nylon Climber Straps



P/N 9000-09350



P/N 9000-85000



P/N 9000-87000



P/N 9000-89000

- Durable, pliable, and comfortable
- Double riveted and feature a protective buckle shield

P/N 9000-09350 Bashlin 85N Top Straps - 1 1/16" x 24"
 P/N 9000-85000 Bashlin 86N One Piece Lower Straps - 1 1/16" x 28"
 P/N 9000-87000 Bashlin 87N Two Piece Lower Straps - 1 1/16" x 28"
 P/N 9000-89000 Bashlin 89N Two Piece Lower Straps w/split ring - 1 1/16" x 28"

Please contact your Altec Supply Account Manager for more information regarding quality Bashlin products.

DECADES OF PROVEN EXPERIENCE...

BASHLIN CLIMBING EQUIPMENT

PERSONAL EQUIPMENT

USA: 1-877-GO ALTEC
(1-877-462-5832)

www.alteconnect.com

Wing Pad



- This wing pad holds the shank more securely than other leather pads
- The climber shank fits inside the pad, reducing movement and adding comfort
- Available with or without padding

P/N 9000-81429 Bashlin 140D; Not Padded
P/N 9000-08142 Bashlin 140DS; Padded

Lineman's Holsters



P/N 9700-91298* and
P/N 9700-91296*

P/N 9000-99956* and
P/N 9700-21953*

* Tools not included

- Reinforced double backs for extra wear
- Available in tan or black
- P/N 9700-91296 and P/N 9700-91298 will hold pliers, rule, screwdriver, Channellock, knife or wrench
- P/N 9700-21953 and P/N 9000-99956 will hold pliers, rule, screwdriver, Channellock, ratchet driver, knife or wrench

P/N 9700-91296	Bashlin 111HLS	4 Pockets	Tan
P/N 9700-91298	Bashlin 111HLSX	4 Pockets	Black
P/N 9700-21953	Bashlin 111HLDS	5 Pockets	Tan
P/N 9000-99956	Bashlin 111HLDSX	5 Pockets	Black

Bashlin Bolt & Nut Bag



- Canvas
- Reinforced base
- Snap or thong attachment

P/N 9000-25000 25BS

78 Series Pole Straps



- 2 plies of pliable latigo leather straps featuring a nylon insert
- Stitching is deeply embedded in the leather for longer wear
- "HL" snap is very similar to the movements used with the single locking snap

P/N 9700-91562	Bashlin 78X-2HL	5'6" long
P/N 9700-76929	Bashlin 78A-2HL	6' long
P/N 9700-91563	Bashlin 78B-2HL	6'6" long

145 Series Climber Pads



P/N 9700-91310

- Features extreme comfort and gives increased climber support
- Double strap design with "spur stay irons"
- Fits Bashlin steel and aluminum climbers
- One pair climber straps included with pads

P/N 9700-91312	Bashlin 145	Without steel insert
P/N 9700-91310	Bashlin 145AC	For Steel Climbers
P/N 9700-91311	Bashlin 145BC	For Aluminum Climbers

Hook-N-Loop Climber Pads



P/N 9700-91308

- No straps and buckles for easy donning
- Comfortable wrap-around padding
- Fit most standard climbers
- P/N 9700-91300 and P/N 9700-91308 feature a metal insert for positive climber control
- P/N 9700-89478 features the standard "T" design

P/N 9700-89478	Bashlin 150V	Climber Pad
P/N 9700-91300	Bashlin 145 ACV	for Steel Climbers
P/N 9700-91308	Bashlin 145 BCV	for Aluminum Climbers

Lowell Wrench Holster



- Reinforced double back for extra wear
- Designed to hold Lowell wrenches

Tool not included

P/N 9700-92825	Bashlin 111LWH	Tan
P/N 9702-78851	Bashlin 111LWHX	Black

50 Series Pole Straps



- 6 ply 1 3/4" neoprene-coated nylon uses a tongue buckle adjustment
- "HL" snap is very similar to the movements used with the single locking snap

P/N 9000-99825	Bashlin 51N-2HL	5'6" long
P/N 9700-23352	Bashlin 52N-2HL	6' long
P/N 9700-89474	Bashlin 53N-2HL	6'6" long



QUALITY EQUIPMENT FOR PROFESSIONAL LINEWORKERS

PERSONAL EQUIPMENT

Bashlin 683X and 662 Harnesses



Bashlin 683X



Bashlin 662RD

- Bashlin body harnesses are Arc Flash rated, per ASTM Standards
- They are available in the standard "H" style, 662 series, and "X" style that are more comfortable and have a front loop for self rescue, or fall protection when using climbing devices

The 683 "X" is Bashlin's premier body harness. Originally designed for the utility industry, this harness sets the standard for comfort, flexibility and ease of use. The hardware is low on the waist, and a loop is in the front for rescue or work positioning. Pass through friction buckles are standard. This is a sized harness. Proper sizing is required for proper performance.

The 662 Series is a fully adjustable, one size fits most full body harness, in the "H" style. Size XL and larger are available. This harness also has a dorsal seat strap and 10,000 lb test web. The full range of back attachment options are available.

- Bashlin's 683XC is an "X" Harness with 24" extension back attachment and a D-Ring; the maximum lanyard length is 4'
- Bashlin's 683XD is an "X" Harness with D-Ring back attachment
- Bashlin's 662RD is an "H" Harness with a D-ring back attachment
- Bashlin's 662AC is an "H" Harness with 24" extension back attachment and a D-Ring; the maximum lanyard length is 4'

All harnesses are available in sizes S-XL.
Please call 1-877-GO ALTEC (1-877-462-5832) for additional information.

NEED A HAND BOOM HANDLE SYSTEM

Climbing on and around an aerial lift can be awkward. Finding a place to grab when climbing up or down can be a little hard. This nylon handle is the solution. It easily mounts to the boom with a ratchet strap. It provides a secure "grab point" when climbing in and around the back of a truck.

P/N 9704-97103 703BHS



USA: 1-877-GO ALTEC
(1-877-462-5832)

www.alteconnect.com

DECADES OF PROVEN EXPERIENCE...

BASHLIN CLIMBING EQUIPMENT

PERSONAL EQUIPMENT

USA: 1-877-GO ALTEC
(1-877-462-5832)

www.alteconnect.com



ReST RELIEF OF SUSPENSION TRAUMA

The Bashlin ReST (Relief of Suspension Trauma) is a light, compact ladder that stores on the lanyard. If during an arrested fall, a lineman finds himself hanging in the air and the calvary is still not there, he simply grabs the loop - extending the ladder. He can stand in the ladder, (and even talk on his cell phone) allowing necessary blood flow to the lower extremities until help arrives.

- A simple, convenient, adaptable method of addressing the question of suspension trauma
- This pack contains a portable ladder that can be mounted on a harness, a lanyard or purchased as a unit with a lanyard
- Packed in an Arc Flash Resistant Pouch
- 6' ladder folds into a small pouch that is always there, but not in the way

P/N 9703-61888 ReST Suspension Trauma Ladder with Pouch
 P/N 9703-61912 1990ReST Suspension Trauma Ladder on
 Harness Back Attachment Extension
 P/N 9703-61914 2304-6HLReST Suspension Trauma Lanyard - 6'

Fall Protection & Rescue System - Boom Mount Rescue System

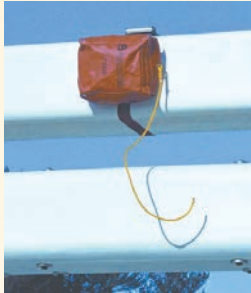

- Designed for use in aerial lift devices
- P/N 9000-00610 attaches to the boom semi-permanently with a ratcheting boom strap and is in a soft vinyl case
- Features aluminum blocks with nylon sheaves and 75' of twisted rope
- A carabiner is provided for attachment to the victim

P/N 9000-00610 Bashlin 700FP

Truck Mount Rescue System

- Designed for use in aerial lift devices
- P/N 660-30007 attaches semi-permanently to the truck with U-Bolts and is in a hard plastic cannister
- Features aluminum blocks with nylon sheaves and 75' of twisted rope
- A carabiner is provided for attachment to the victim

P/N 660-30007 Bashlin 700FWI



Bashlin PARA-PAK Rescue Device

- A lightweight, self-contained rescue system for emergency evacuation of an aerial lift device
- Para-Pak includes the anchor carabiner, harness carabiner, tubular Kevlar rescue line that is arc resistant and easy to store with your choice of a mechanical or 4 hole friction device for descent control
- If the handle on the mechanical friction device is released the descent will halt
- Complete system comes in a lightweight low profile package that will fit neatly in the basket of the lift truck
- P/N 9701-64176 and P/N 9701-64179 Para-Pak Self Rescue from a Stranded Aerial Platform: this system provides a means of egress from a non-functioning aerial platform or lift; a 4 hole friction device is used to control the descent
- P/N 9701-64173 and P/N 9701-64174 Para-Pak-AL Self Rescue from a Stranded Aerial Platform: provides a means of egress from a non-functioning aerial platform or lift incorporating the added feature of stopping the descent when the operator control is released (hands free); a mechanical friction device is used to control the descent

P/N 9701-64173 SR683PKWL-75
 P/N 9701-64174 SR683PKWL-150
 P/N 9701-64176 SRPAK-75
 P/N 9701-64179 SRPAK-150

Positive Control Descender 4.00 lbs.
 Positive Control Descender 4.75 lbs.
 Para-Pak with PED Descender 3.75 lbs.
 Para-Pak with PED Descender 4.50 lbs.

75' of Line Length
 150' of Line Length
 75' of Line Length
 150' of Line Length



These kits do not include harness nor lanyard. Both require harnesses that feature a front rappel point for self-rescue. Other line lengths are available. Please call 1-877-GO ALTEC for a quote.



Delta™ Harnesses



- Stand-Up Dorsal D-Ring
- Protected Labels With I-Safe™
- Repel™ Webbing
- 420 lb. Capacity
- Impact Indicators
- No Tangle Design
- Revolver™ Vertical Torso Adjuster
- Universal Sizing

Delta Vest Style Harnesses - Back D-Ring*:

- Model 1110600 Quick Connect Buckles**
- Model 1102000 Tongue Buckles**
- Model 1103321 Pass-Thru Buckles**

Delta Vest Style Harnesses - Front/Back D-Rings*:

- Model 1102090 Quick Connect Buckles**
- Model 1107807 Tongue Buckles**
- Model 1112126 Pass-Thru Buckles**

* Other Models & Styles Available



LANYARD KEEPERS

Delta™ lanyard keepers hold your unused snap hooks and help reduce trip hazards.



TECH-LITE™ QUICK CONNECT BUCKLES

Lightweight aluminum alloy buckles for fast and easy connections.

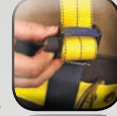

REVOLVER™ VERTICAL TORSO ADJUSTER

Simple and fast adjustment that eliminates loose ends and locks into place preventing slippage.

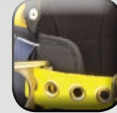

DELTA™ COMFORT HIP PAD

Improved ergonomic fit constructed with a soft, breathable, comfortable interior that supports your back and hips.

Delta™ Kevlar/Arc Flash Full Body Harness

- Delta No-Tangle™ design with tongue buckle straps for added comfort and fast, easy donning
- Spring loaded stand-up back D-ring ensures fast, easy, and safe connections
- Patented cross-over design provides added comfort and versatility with an adjustable front D-ring
- Parachute buckles on lower shoulder straps for quick and easy adjustment
- Polyester webbing construction for added durability
- Plated hardware for corrosion resistance
- Meets or exceeds all applicable industry standards including OSHA, ANSI and the stringent ANSI Z359
- While others have tried to copy this patented harness, no one comes close. Designed for comfort and ease of use, the absence of a chest strap and waist belt provides maximum freedom of movement while still providing connecting points for your fall arrest, restraint, work positioning, or rescue system

P/N 9703-25386 1102950 Universally sized



Delta™ Arc Flash/Flame Resistant Harness



- Designed to meet the specific needs the utility industry
- No metal above the waist for reduced conductivity
- Back web loop replaces back D-ring reducing weight and electrical conductivity, front web loop for rescue
- Delta No-Tangle™ design for added comfort, easy donning
- One-handed quick connect buckles make putting on, adjusting and removing the harness a snap and provide a memory fit – adjust the harness once and it stays that way
- Torso buckles adjust easily, hold the straps firmly in place for a 5-point adjustment system
- 7,000 lb. Nomex®/Kevlar® webbing construction for added security, durability, flame resistance
- Plated hardware for corrosion resistance
- Arc Flash resistant up to 40 cal/cm², ASTM F887-04 compliant
- Meets or exceeds all applicable industry standards including OSHA, ANSI Z359 and ASTM F887-04

P/N 9703-25387 1110810 Medium

P/N 9703-25388 1110811 Large

P/N 9703-25390 1110812 X-Large

ExoFit NEX™

ExoFit NEX™ Harnesses:

- Hybrid Comfort Padding: marries premium comfort & durability
- Duo-Lok™: Lightweight one-handed use with memory-fit

- Repel Technology Webbing for up to 5 times more abrasion resistance, water repellency
- Revolver™: Simple and fast adjustment that locks into position
- Built in carrying pocket on chest & covered labels
- Meets or exceeds all applicable industry standards including OSHA and ANSI including the stringent ANSI Z359
- Reflective material for better visibility
- Also features Breakaway lanyard keepers, Integrated Trauma Straps, Impact Indicator Stitches, Tech-Lite™ Aluminum D-rings
- Max Capacity: 420 lbs.
- Harness Weight 3.6 lbs.

ExoFit NEX™ CrossOver Harness:

- Crossover models feature front-mounted D-Ring making this style ideal as a rescue harness and for ladder climbing applications

ExoFit NEX™ Tower Climbing Harness:

- Feature tool loops for carrying equipment, sewn-in hip pad with belt, removable seat sling with positioning D-rings

ExoFit NEX™ Global Wind Energy Harness with Belt

- Belt Tech-Lite™ front, back, and side D-rings, Duo-Lok™ quick connect buckles and sewn-in hip pad, body belt
- OSHA/ANSI Compliant - North America CE EN361/EN358 Compliant - Europe, Middle East, Africa
- Replaceable lumbar protector, radio holster, integrated trauma straps, loops for tools/equipment

ExoFit NEX™

P/N 9703-25356	1113000	X-Small
P/N 9703-25359	1113001	Small
P/N 9702-94631	1113004	Medium
P/N 9702-94635	1113007	Large
P/N 9702-94637	1113010	X-Large
P/N 9703-25361	1113013	XX-Large

ExoFit NEX™ Tower Climbing Harness

P/N 9703-25362	1113190	Small
P/N 9703-25363	1113191	Medium
P/N 9703-25364	1113192	Large
P/N 9703-25365	1113193	X-Large
P/N 9703-25371	1113194	XX-Large

ExoFit NEX™ Global Wind Energy Harness with Belt

P/N 9703-25373	1113090	X-Small	P/N 9703-25379	1113215	Small
P/N 9703-25374	1113091	Small	P/N 9703-25380	1113216	Medium
P/N 9703-25375	1113094	Medium	P/N 9703-25381	1113217	Large
P/N 9703-25376	1113100	Large	P/N 9703-25382	1113218	X-Large
P/N 9703-25377	1113103	X-Large	P/N 9703-25383	1113219	XX-Large

The ExoFit NEX™ Arc Flash Tower Harness



- PVC coated aluminum back and front D-rings, belt with pad and PVC coated aluminum side D-rings, seat sling with PVC coated suspension D-rings, Nomex®/Kevlar® web and comfort padding, locking quick connect buckle leg straps (size Small).
- Arc flash rated
- Nomex®/Kevlar® shoulder, back and leg comfort padding
- Tech-Lite™ stand-up PVC coated aluminum back D-ring
- Tech-Lite™ PVC coated aluminum front D-ring
- Body belt/hip pad with PVC coated Tech-Lite™ aluminum side D-rings
- Removable seat sling, aluminum board, and Tech-Lite™ PVC coated aluminum suspension D-rings
- Duo-Lok™ quick connect chest and leg straps
- Leather insulators
- Nomex®/Kevlar® webbing
- Built-in lanyard keepers
- Revolver™ vertical torso adjusters
- Integrated flame resistant trauma straps
- Built-in reflective materials
- Protected labels, equipped with i-Safe™

ExoFit™ XP Utility Harness

P/N 9706-40786	1113357	Small
P/N 9706-40787	1113358	Medium
P/N 9706-40788	1113368	Large
P/N 9706-40789	1113369	X-Large



Left: ExoFit NEX™ Harness

Right: ExoFit NEX™ Cross Over Harness



Left: ExoFit NEX™ Global Wind Energy Harness with Belt



ExoFit NEX™ Tower Climbing Harness

ExoFit™ Harnesses



- The ultimate in comfort and designed specifically for utility workers
- Made of soft and light-weight, yet extremely durable materials

- Based on the concept of a single piece of material constructed in the shape of an "X" that wraps around the user for the ultimate in no-tangle donning and comfortable security
- Shoulder, hip, and leg padding keeps user comfortable during long hours of work
- Color-coded quick-connect buckles for fast and easy donning
- 7,000 lb. nylon or Nomex®/Kevlar webbing options
- Nomex®/Kevlar blend fabric (known for its flame/water resistance and durability) is used in back, hip, and leg pads
- Dorsal web loop for no metal connections; PVC-coated hardware option for non-conductive, non-sparking applications

- Front rescue loops for emergency descent, bucket truck/high angle rescue
- Leather insulators behind metal hardware for added protection
- Meets ASTM F887-05, OSHA, and ANSI Z359.1 standards

ExoFit™ XP Arc Flash Harness

- PVC-coated back D-ring, 7,000 lb. Nomex®/Kevlar® web, Nomex®/Kevlar® back, shoulder and leg padding, PVC-coated pass-thru buckles

ExoFit™ XP Utility Harness

- Back web loop and front rescue loops, 7,000 lb. nylon web, Nomex®/Kevlar® back, removable shoulder and leg padding, leather insulators, quick-connect buckles

Seat-Belt™ 4D Lineman Belt

- Built-in contoured comfort and support seat
- Unique design moves center of gravity upward
- Rolled edges add durability and comfort at the hips
- Built-in tool snaps and rings
- Integral leather tape thong
- Tongue buckle style body belt
- Gut strap with locking quick connect buckle
- 2 large S-shaped full-floating D-rings at hips
- 2 small D-rings for fall restrict device
- Made with 100% top grain leather from Red Wing, MN
- Metal ID plate with vinyl label, equipped with i-Safe™
- Available in sizes D18-D30



P/N 9706-37204	1001392	D18
P/N 9706-37205	1001393	D19
P/N 9706-37206	1001394	D20
P/N 9706-37207	1001395	D21
P/N 9706-37208	1001396	D22
P/N 9706-37209	1001397	D23
P/N 9706-37210	1001398	D24
P/N 9706-37211	1001399	D25
P/N 9706-37212	1001400	D26
P/N 9706-37213	1001401	D27
P/N 9706-37214	1001402	D28
P/N 9706-37215	1001403	D29
P/N 9706-37216	1001404	D30



Left: ExoFit™ XP Utility Harness

Right: ExoFit™ XP Arc Flash Harness

ExoFit™ Full Body Harness

P/N 9704-75111	1110100	Small
P/N 9000-11101	1110101	Medium
P/N 9000-11112	1110102	Large
P/N 9000-11103	1110103	Extra Large

ExoFit™ XP Utility Harness

P/N 9000-11108	1110840	Medium
P/N 9000-11109	1110841	Large
P/N 9000-11107	1110842	Extra Large

ExoFit™ XP Arc Flash Nomex/Kevlar Harness

P/N 9702-50275	1110890	Medium
P/N 9700-67384	1110891	Large*
P/N 9702-50276	1110892	Extra Large

2D Lineman Belt

- Rolled edges add durability and comfort at the hips
- Built-in tool snaps and rings
- Integral leather tape thong
- Tongue buckle style body belt
- 2 large S-shaped full-floating D-rings at hips
- Made with 100% top grain leather from Red Wing, MN
- Metal ID plate with vinyl label, equipped with i-Safe™
- Available in sizes D18-D30



P/N 9706-37217	1001379	D18
P/N 9706-37218	1001380	D19
P/N 9706-37219	1001381	D20
P/N 9706-37220	1001382	D21
P/N 9706-37221	1001383	D22
P/N 9706-37222	1001384	D23
P/N 9706-37223	1001385	D24
P/N 9706-37224	1001386	D25
P/N 9706-37225	1001387	D26
P/N 9706-37226	1001388	D27
P/N 9706-37227	1001389	D28
P/N 9706-37228	1001390	D29
P/N 9706-37229	1001391	D30

PERSONAL EQUIPMENT

USA: 1-877-GO ALTEC
(1-877-462-5832)

www.alteconnect.com

ShockWave™2 Shock Absorbing Lanyard

- Expands to 6 ft. and contracts to 4 1/2 ft. in reaction to your movements
- 100% tie-off style helps user remain constantly connected
- Reduces trip fall hazards, dragging and snagging for complete freedom of movement
- P/N 9701-52035 features easy-to-use self locking snap hooks at center and aluminum hooks (2 1/4" opening) at the leg ends
- P/N 9702-32685 features self-locking snap hooks at both ends
- Abrasion resistant tubular webbing for durability and longevity
- Impact indicator allows user to visually inspect unit for a fall
- Limits arresting forces to 900 lbs. or less
- P/N 9702-32685 meets or exceeds all applicable industry standards including OSHA, ANSI and the stringent ANSI Z359

P/N 9701-52035 1244409 Twin-Leg Style
P/N 9702-32685 1244306 Single-Leg Style, Snap Hooks

ShockWave™2 Nomex/Kevlar Arc Flash Shock Absorbing Lanyards



P/N 9703-25391



P/N 9702-06097



P/N 9703-25395

- Great for welding applications and for use with the ExoFit XP Arc Flash and Delta II Arc Flash harnesses
- Nomex/Kevlar tubular webbing outer jacket
- Expands to 6 ft. and contracts to 4 1/2 ft. in reaction to your movements
- Reduces trip fall hazards, dragging and snagging for complete freedom of movement
- Choker web loop for use with web loop harnesses and easy to use self locking snap hook at other end
- Impact indicator allows user to visually inspect unit for a fall
- 6 ft. in length
- Limits arresting forces to 900 lbs. or less
- Electric arc tested to 40 cal/cm2
- Meets or exceeds all applicable industry standards including OSHA and ASTM F887-05

Shock Absorbing Lanyard

P/N 9703-25391 1244610 Shock-Absorbing Lanyard

Shock Absorbing Lanyard with Web Loop:

P/N 9702-06097 1244611 Single-Leg Style

P/N 9703-25395 1244631 Twin Leg Style, 100% Tie-Off

Force2™ Rescue Lanyard 100% Tie-Off for Wind Energy (6')



- Complete with 3" gated Saflok Max™ steel hooks to tie off around large rails and anchor points or 2 1/4" gated aluminum snap hooks to reduce lanyard weight

Force2™ Shock Absorbing Wind Energy Lanyard



- A 100% tie-off lanyard with elastic webbing
- 3,600 lb hooks on leg ends
- Tech-Lite™ rescue D-rings & a nylon shock pack with a PVC resist cover to protect against abrasion while climbing

and descending

- OSHA/ANSI Compliant - North America
- CE EN355 Compliant - Europe, Middle East, Africa

P/N 9703-25392 1244760

- Elastic webbing reduces tripping hazard and keep lanyard leg out of the worker's way
- PVC shock pack cover protects labeling and nylon shock pack from abrasion while climbing and descending towers.
- Designed specifically for the challenges associated with turbine construction, maintenance or inspections.
- Designed for individuals weighing up to 310 lbs. and can resist up to a 12' free fall. They've also been tested for 6 ft. free falls on individuals weighing up to 420 lbs. This is important when working on top of the nacelle and the only available tieoff point is at your feet
- A 5/8" polyester rope model is ideal for companies requiring rope for their crew
- CE EN355 Compliant - Europe, Middle East, Africa

P/N 9703-25394 1242551 Saflok Max, 1242550 Alum. Rebar Hooks

Workers are always at risk from falling objects when overhead work is being performed. If a worker ab you loses his grip, you are in danger of being struck by power tools, two-way radios or hammers. Injuries can range from minor abrasions to concussions, to blindness or even death.

- Lanyards extend up to 50" to give you ample room to easily operate your tools—and retract down to 34" to stay out of your way
- Reduce workplace injury, equipment damage and improve productivity by allowing you to connect your tools to your tool belt or harness by equipment added safety - preventing "panic-grab" situations
- Feature stainless steel hooks and/or choker style connectors for fast and easy attachment

P/N 9703-63092 1150914 **Single Carabiner with Choker, 15 lb. Capacity (shown)**

P/N 9703-63093 1150915 **Double Carabiner, 15 lb. Capacity**

P/N 9703-63117 1150916 **Double Carabiner, 30 lb. Capacity**

P/N 9703-63128 1150917 **Twin Leg Triple Carabiner, 30 lb. Capacity**



Cynch-Lok™



- The most user-friendly device of its kind meeting stringent CSA 59.14 standards
- Features almost effortless adjustment as developed from real pole climbers
- Allows you to easily hitch-hike poles (reposition, move or jump the strap upwards) with a hand position that's comfortable
- Moves past obstacles without difficulty
- Exterior straps can be changed depending on the type and size of pole you're climbing; interchangeability eliminates the need to purchase multiple devices and adds to Cynch-Lok™'s longevity by allowing you to replace components
- Unique design "cynches" around a pole in the event of a cut-out or fall. When used correctly, it limits your fall distances in accordance with CSA standards

P/N 9702-77099 1204057 **Cynch-Lok™ for Distribution Poles**

P/N 9702-77098 1204058 **Cynch-Lok™ for Transmission Poles**

Suspension Trauma Strap



- Suspension Trauma Safety Strap helps prevent the effects of suspension trauma after a fall
- Allows worker who is suspended to stand up in their harness to relieve pressure
- A safety accessory that can be attached to most harness brands/styles right in the field
- Installation to your harness is fast and efficient - just choke off to strap and it's ready
- Extremely compact and lightweight design stays out of the worker's way
- Deployment and operation is fool-proof, simply unzip, and hook straps together
- Continuous loop design allows for either one or two-foot suspension relief without pinching

P/N 9701-86621

9501403

Talon™ Self-Retracting Lifeline

- Compact, lightweight design
- 8 ft. or 2.4m of 19mm nylon webbing
- All metal braking system for durability
- Designed for smooth, consistent operation
- Quick-connect handle for direct attachment to anchorage or harness
- Self-locking swivel snap hook with impact indicator
- Meets or exceeds all applicable industry standards including OSHA, ANSI and the stringent ANSI Z359 standards including OSHA and ASTM F887-05

P/N 704-21244 3101001



Rope Grab (5/8" Diameter Rope)



- Fits 5/8" diameter rope lifeline
- Revolutionary design - less sensitive to rope variations; worn rope does not lock-up
- Mobile type, automatically follows worker providing maximum freedom of movement
- Utilizes both inertia and cam locking system for added safety - preventing "panic-grab" situations
- Energy absorbing design reduces the forces generated upon a worker in the event of a fall
- Attach or detach anywhere along the lifeline for added versatility

- Corrosion resistant stainless steel and thermoplastic construction
- Use with 3 ft. EZ Stop® II shock absorbing lanyard (part#120007)
- Meets or exceeds all applicable industry standards

P/N 9701-50645 5000335

50 Ft. Sealed-Blok™

- The Sealed-Blok lifeline extends and retracts enabling the user to move about within a recommended working area at normal speeds
- Should a fall occur, a speed-sensing brake system (4.5 ft./sec.) will activate, stopping the fall and reducing the forces imposed on the user to 900 lbs. or less.

P/N 9703-63129 3400900



Nano-Lok™ Arc Flash Self-Retracting Lifeline with Anchor Hook

Nano-Lok™ is ergonomically designed for ease-of-use and is ideal for direct connection to most harnesses. The extremely compact and lightweight design is virtually unnoticeable on your back, staying out of the worker's way and making it ideal as a lanyard replacement. Whether your application requires single or twin leg configurations, mounting to an overhead anchor or for connection directly to harness, there are dozens of models to choose from to suit almost any application. Nano-Lok™ locks quickly—stopping a fall within inches—providing more protection at low heights. In addition, tension is always kept on the lifeline, which reduces dragging, snapping and trip falls. Both features are key safety improvements.



- Arc flash rated
- 8 ft. (2.4m) 3/4" (19mm) Kevlar® web lifeline
- Extremely compact, lightweight design
- Quick activating speed sensing brake system
- Swiveling anchorage loop with 13" (33mm) web extension and aluminum snap hook
- Aluminum self-locking carabiner on lifeline
- Tough and impact resistant thermoplastic housing
- High capacity energy absorber and impact indicator protected by Kevlar® fiber cover

P/N 9706-40784 3101575* 8 ft. (2.4m) 3/4" (19mm) Kevlar® fiber webbing and aluminum carabiner, swiveling anchor loop with 13" (33mm) web extension with aluminum snap hook.

* Several Models are Available. Please call 1-877-GO ALTEC (1-877-462-5832) for more information.

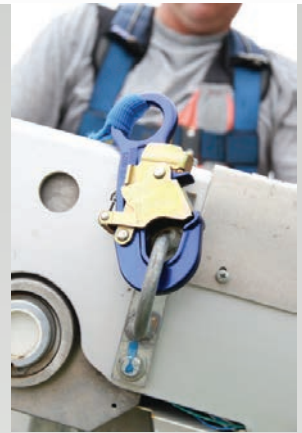

Nano-Lok™ Arc Flash Quick Connect Self-Retracting Lifeline

- Arc flash rated
- 8 ft. (2.4m) 3/4" (19mm) Kevlar® web lifeline
- Tough and impact resistant thermoplastic housing
- Quick activating speed sensing brake system
- Built-in connector for single-leg SRL direct attachment to harness
- Self-locking snap hook on lifeline
- Swiveling anchorage loop
- High capacity energy absorber and impact indicator protected by Kevlar® fiber cover

P/N 9705-40785 3101527* 8 ft. (2.4m) 3/4" (19mm) Kevlar® fiber webbing and aluminum carabiner, swiveling anchor loop with 13" (33mm) web extension with aluminum snap hook.

* Several Models are Available. Please call 1-877-GO ALTEC (1-877-462-5832) for more information.



= rollgliss™ =

SIMPLY THE BEST ESCAPE SOLUTION ON THE MARKET.

Integrated Rope Ears

Allows for greater descent speed control in assisted rescues



Dual Redundant Brakes

Automatic descent with added security, safety and peace of mind

Cast Aluminum Housing

Lightweight and extremely durable cast housing

Durable Rope

3/8" Static Kermantle Rope
NFPA – L rated for durability.

Steel Snap Hooks

3/4" gate opening—
3,600 lb. gate strength

Multiple Length Options

Lengths between 50 ft.
and 500 ft.



Anchorage

Used to anchor the device with either a carabiner or a sling

Bi-Directional Hub

Rope descends from either side which brings one hook up as the other goes down. Allowing for immediate use after each descent.

- P/N 9704-34713 3305040** 50 ft. Length*
- P/N 9704-34714 3305041** 100 ft. Length*
- P/N 9704-34715 3305042** 200 ft. Length*
- P/N 9704-34716 3305043** 300 ft. Length*
- P/N 9704-34717 3305044** 400 ft. Length*
- P/N 9704-34718 3305045** 500 ft. Length*

* Lengths are Working Lengths



**Fully Automatic, Hands-Free Descent.
Easier To Use And Requires Less Training!**



The SuperSqueeze offers superb Wood Pole Fall Restriction and offers the easiest adjustment on the market. With Buckingham's patent pending WebGrab the SuperSqueeze can be adjusted with just a flick of the wrist. The SuperSqueeze can be configured to fit many climbing styles and needs, and its modular design makes it easy to change out worn or damaged components or straps in the field.



Featuring woven inner strap; features snap hooks on woven strap:
P/N 9703-57697 Model 488W2Q3 for Distribution
P/N 9703-57707 Model 488TW2Q3 for Transmission

Featuring Woven Inner Strap and Carabiners:
P/N 9703-15663 Model 488W2 for Distribution
P/N 9703-57716 Model 488TW2 for Transmission



Featuring rope inner strap; features snap hooks on woven strap:
P/N 9703-57722 Model 488RQ4 for Distribution
P/N 9703-57725 Model 488RTQ4 for Transmission

Featuring Rope Inner Strap and Carabiners (top right):
P/N 9703-12216 Model 488R for Distribution
P/N 9703-48658 Model 488RT for Transmission



Featuring the Patent Pending WebGrab for the Easiest Adjustment for the Circumference of the Pole



PERSONAL EQUIPMENT

USA: 1-877-GO ALTEC
(1-877-462-5832)

www.alteconnect.com

9-8 - BuckAdjuster



- Fully adjustable positioning rope lanyard
- 8' in length and 1/2" in diameter
- With a red core wear indicator
- Features the patent pending BuckGrab
- Clear protective tube lengthens rope life
- Stitched eye allows user to minimize length for easy storage
- Available in additional lengths upon request

P/N 9701-62864 9-8

9A4-8 - BuckAdjuster with Wear Guard



- Fully adjustable positioning rope lanyard
- 8' in length and 1/2" in diameter
- With a red core wear indicator
- Features the patent pending BuckGrab
- Clear protective tube lengthens rope life
- Stitched eye allows user to minimize length for easy storage
- Available in additional lengths upon request

P/N 9705-29432 9A4-8

SuperStrap

Buckingham's SuperStraps have the same, easy-to-use adjustment as the popular BuckAdjuster.

Secondary Web Lanyard / Positioning Strap

- Features the patent pending WebGrab for easy adjustment
- No more holes to find or run out of as with conventional positioning straps
- Made from 6 ply neoprene nylon with red warning core.
- Available in any length with 2 snaps



Shown Above:

P/N 9703-58352 336099E 6' Length
P/N 9703-58374 336699E 6.5' Length
P/N 9703-58385 337099E 7' Length
P/N 9703-58388 337699E 7.5' Length
P/N 9703-58409 338099E 8' Length

Secondary Web Lanyard

- Features the patent pending WebGrab for easy adjustment
- Features all the benefits of web combined with the easy adjustment of rope
- Designed to use climbing for over obstructions



Shown Left:

P/N 9703-57749 48129W2Y-6 6' Length
P/N 9703-57763 48129W2Y-7 7' Length
P/N 9703-42646 48129W2Y-8 8' Length
P/N 9703-57766 48129W2Y-9 9' Length
P/N 9703-57771 48129W2Y-10 10' Length

2402 - Handline Carrier

• A nylon handline carrier with a hole to easily secure it to the body belt with a bolt or zip tie, that will straighten when approximately 14-18 lbs of pressure is applied, allowing the hand line to pull free

P/N 9701-45107 2402



21401C- Hook and Loop Climber Footstraps

• Manufactured from soft, pliable 1 3/4" nylon, this foot strap offers an increased surface area for added comfort to the top and back of the foot
• The hook and loop cinch provides a fast and easy attachment while providing the user an extra tight fit
• Overall length 28"

P/N 9705-86594 21401C

2019M - Stacked 4 Dee Dri-Lex® Body Belt with Back Saver



• A new version of the lightweight Dri-lex® lined body belt with stacked dee rings
• Ideal for use with a secondary lanyard.
• 2 large full float double bar dees 2 small dees
• Back support; no gut strap
• Weight 6.35 lbs

P/N 9702-29443	2019M	D22	P/N 9702-56213	2019M	D27
P/N 9702-29442	2019M	D23	P/N 9702-37175	2019M	D28
P/N 9703-29799	2019M	D24	P/N 9702-93121	2019M	D29
P/N 9702-29441	2019M	D25	P/N 9703-29803	2019M	D30
P/N 9702-22175	2019M	D26	P/N 9702-38338	2019M	D31

2018M - Full Float 4 Dee Dri-Lex® Body Belt with Back Saver

The stacked 2018M 4 dee body belt features:

- Dri-lex® lining
- Stacked dee rings
- 2 large full float double bar dee
- 2 small dee rings
- Removable MAN RATED gut strap (Must be used with a Buckingham provided gut strap)

P/N 9702-29450	2018M	D23
P/N 9702-63492	2018M	D24
P/N 9702-99002	2018M	D25
P/N 9702-29440	2018M	D26
P/N 9702-29439	2018M	D27
P/N 9702-22851	2018M	D28
P/N 9702-29438	2018M	D29
P/N 9702-36116	2018M	D30
P/N 9702-31692	2018M	D31



Buck Mobility Belt

This REVOLUTIONARY belt offers a man rated upper belt strap that is bound to the lower work positions strap by 1 3/4" web. The four dee ring belt supports the use of wood pole fall restriction devices, like the New Buckingham SuperSqueeze. Your back will thank you for the fully padded 9" high back wrapped in quality ultra-soft leather for that instant "broken in" feel.

Features & Benefits Include:

- 9" high fully padded body
- Lined with quality ultra-soft leather
- 2 Full float lower primary dee rings
- 2 small upper dee rings for secondary lanyard
- Replaceable man rated upper strap (always use a Buckingham replacement strap)
- No lower strap

P/N 9704-51147	20182M-D18
P/N 9704-93689	20182M-D19
P/N 9704-51174	20182M-D20
P/N 9704-51143	20182M-D21
P/N 9704-51180	20182M-D22
P/N 9704-51153	20182M-D23
P/N 9704-51123	20182M-D24
P/N 9704-51170	20182M-D25

P/N 9704-51155	20182M-D26
P/N 9704-51160	20182M-D27
P/N 9704-51178	20182M-D28
P/N 9704-93694	20182M-D29
P/N 9704-93701	20182M-D30
P/N 9704-93703	20182M-D31
P/N 9704-68856	20182M-D32



Please call 1-877-GO ALTEC (1-877-462-5832) for additional quality Buckingham Mfg. products.

2000M - Full Float Leather Body Belt

- Leather belt strap with nylon center for strength
- Floating dees provide 4" lateral movement
- Hand crafted with 5 1/2" foam cushioned pad reinforced with rawhide lace
- Weight 7 lbs.
- Add suffix 'E' to order with 4 in line dee rings

BLACK			BROWN		
P/N 9701-35523	2000M-BL	D20	P/N 9703-57667	2000M-BR	D20
P/N 9000-70656	2000M-BL	D21	P/N 9703-09737	2000M-BR	D21
P/N 9701-15609	2000M-BL	D22	P/N 9000-70588	2000M-BR	D22
P/N 9701-18243	2000M-BL	D23	P/N 9703-57691	2000M-BR	D23
P/N 9701-92302	2000M-BL	D24	P/N 9701-50760	2000M-BR	D24
P/N 9701-36728	2000M-BL	D25	P/N 9703-23033	2000M-BR	D25
P/N 9701-53797	2000M-BL	D26	P/N 9702-98615	2000M-BR	D26
P/N 9703-57654	2000M-BL	D27	P/N 9703-57677	2000M-BR	D27
P/N 9701-35529	2000M-BL	D28	P/N 9703-57694	2000M-BR	D28

Man Rated Gut Straps

- Use with any two dee body belt
- Completely adjustable for user's comfort
- Belt features 5000 lb. man rated connections and leather-lined strap,
- **Model 6263** features a standard tongue buckle
- **Model 6264** features easy-to-use quick connect buckles

Model 6263 Part Number	Model 6264 Part Number	Belt Size	Waist Size
P/N 9703-03209	P/N 9703-58413	Small	28-32
P/N 9703-03214	P/N 9703-58436	Medium	32-36
P/N 9703-23555	P/N 9703-58437	Large	36-40
P/N 9703-03215	P/N 9703-58440	X-Large	40-44

Buck LineBacker

- Offers ergonomic advantages and turn a two dee belt into a four dee belt
 - Linebackers feature an abdominal stabilizer, dee ring distributing pads, and lumbar support (removable in **Model 4201**, permanent in **Model 4202**)
 - The deluxe **Model 4201** also features harness attachment buckles to attach to a harness (to order attachable harness, add option '4C' to harness model number)
- Please call 1-877-GO ALTEC (1-877-462-5832) for more information.

Model 4201 Part Number	Model 4202 Part Number	Size	Waist Size
P/N 9706-00943	P/N 9706-00947	Small	28-32
P/N 9706-00944	P/N 9706-00948	Medium	32-36
P/N 9706-00945	P/N 9706-00950	Large	36-40
P/N 9706-00946	P/N 9706-00953	X-Large	40-44

2100M - 4 Dee Body Belt



- The high-quality features of the 2000M with stacked dee rings
- Ideal for use when a secondary lanyard is used to climb over obstructions
- Highest quality leather with a 5 1/2" foam cushioned pad reinforced with rawhide lace, bridge pieces and belt straps crafted of leather with a nylon center to provide strength and longer life, and full floating primary dee rings that provide 4" lateral movement to reduce the wear on the pole strap
- 2 large full float double bar dee rings; 2 small dee rings
- 9" back pad
- Waist strap only; no upper gut strap
- Weighs 7.8 lbs

2107M- 4 Dee Body Belt



- Same as the 2100M Model belt with the addition of the Removeable MAN RATED gut strap (Must be used with a Buckingham-provided MAN RATED gut strap)
- Weighs 9.2 lbs



Also available in Burgundy (Model 2000M-BU). Please call 1-877-GO ALTEC (1-877-462-5832) for additional information.



Model 4201 - Deluxe LineBacker



Model 4202 LineBacker

P/N 9703-58134	2100M	D21
P/N 9703-58143	2100M	D22
P/N 9703-58147	2100M	D23
P/N 9703-14148	2100M	D24
P/N 9703-58153	2100M	D25
P/N 9703-58155	2100M	D26
P/N 9703-58165	2100M	D27
P/N 9703-58167	2100M	D28

P/N 9703-58304	2107M	D21
P/N 9703-58306	2107M	D22
P/N 9703-58310	2107M	D23
P/N 9703-58326	2107M	D24
P/N 9703-58327	2107M	D25
P/N 9703-58331	2107M	D26
P/N 9703-53547	2107M	D27
P/N 9703-58340	2107M	D28

TB94089A - Titanium Replaceable Gaff Pole Climbers

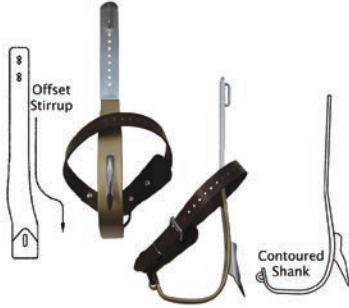

This POPULAR CHOICE Titanium Pole Climber offers:

- Contoured shank
- Off-set stirrup
- 16 degree dowel and screw replaceable gaffs
- 21391 nylon foot straps
- Includes standard length sleeves [9204] adjusting from 16 1/4" to 18 3/4". Long sleeves, adjusting from 19 1/4" to 21 3/4", may be ordered [9202]. Add suffix 'L' to the climber part number for long sleeves.
- Climber with gaff weighs 1 lb. 2 oz.

P/N 9701-15903 TB94089A

T94089A - Titanium Pole Climber - Non-Contoured Shank

- Non-contoured shank
- Off-set stirrup
- 16 degree dowel and screw replaceable gaffs
- 21391 nylon foot strap
- Includes standard length sleeves [9204] adjusting from 16 1/4" to 18 3/4". Long sleeves, adjusting from 19 1/4" to 21 3/4", may be ordered [9202]. Add suffix 'L' to the climber part number for long sleeves.
- Climber with gaff weighs 1 lb. 2 oz.

P/N 9702-08451 T94089A



SB94089A - Steel Replaceable Gaff Pole Climbers

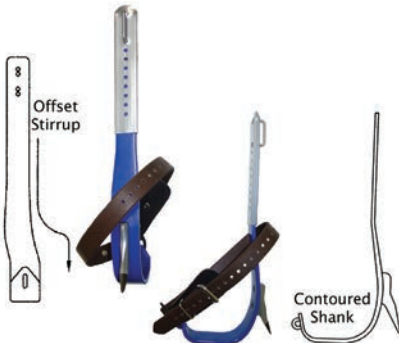

This POPULAR CHOICE Steel Pole Climber offers:

- Contoured shank
- Offset stirrup
- 16 degree dowel and screw replaceable gaffs
- 21391 nylon foot straps
- Includes standard length sleeves [9204] adjusting from 16 1/4" to 18 3/4". Long sleeves, adjusting from 19 1/4" to 21 3/4", may be ordered [9202]. Add suffix 'L' to the climber part number for long sleeves

P/N 9000-70575 SB94089A

A94089A - BuckAlloy Aluminum Climber with Nylon

- Features new GRiP (Gaff Ridge Position) technology that keeps the gaff pointed toward the heart of the pole which aids in preventing cutouts, allows for a better, more comfortable setting of the foot and arch, and allows optimum gaff placement on the pole and promotes ease of climbing.
- Rated to 350 lbs. and exceeds ASTM F887
- Unmatched comfort in an aluminum climber
- Non contoured, off-set replaceable gaff pole climbers
- Lightest, yet most durable climber in the industry - Leg Iron only; 2 lbs/pair
- Aluminum alloy used in transport applications including marine, automotive and aviation due to its high strength to density ratio; alloy blend contributes to superior product life cycle
- Dowel and screw design allows for easy gaff change out
- Made in the USA



P/N 9706-01101 A94089A

Dowel & Screw Replaceable Climbers

Buckingham Replaceable Climbers are now even easier to replace! The Dowel and Screw Replaceable Climber Gaffs are available for any climber issued after January 2011.

- Poles Gaffs Designed For CCA Poles

P/N 9703-58452 NB9106A For Titanium & Steel Climbers
P/N 9706-37184 A9106A Replacement Gaffs for Aluminum Climbers

Standard Pole Gaffs for Climbers

P/N 9703-58455 Model NB9206A
P/N 9706-01099 A9206A
Replacement Gaffs for Aluminum Climbers



Buckingham 6909A - Snap On Gaff Guard

- Easy Snap On Gaff Guard fits all Buckingham replaceable pole gaffs with a 16 degree angle (A style)
- P/N 9702-48768 6909A**

Buckingham 6909U - Universal Fit Gaff Guard



- Universal coated wire pole gaff guard made to fit all Buckingham, Bashlin, Klein and Stringer Brooks pole climbers.
- P/N 9700-97336 6909U**

35032 - Climber Pad



- Leather 'C' pad designed with a metal insert and oversized felt liner for additional comfort.
- Liner edge minimizes chafing on the leg. New improved inserts won't bend and we've modified the insert loop to prevent sleeve roll out.

Requires a 26" strap (sold separately)

P/N 9701-90903 35032 For Titanium & Steel Climbers
P/N 9706-01110 350321 For Aluminum Climber

3502C The Original Velcro® Wrap Pad with Insert



- An angled style Velcro® pad that features a continuous wrap with a metal insert
- Measures 4" W with 3/4" padding
- Rolled edge to prevent chafing
- Stitched tunnel for a secure fit
- Cinch loop provides tight fit

P/N 9700-54740 3502C For Titanium & Steel Climbers
P/N 9706-01113 35021C For Aluminum Climber

3202C - Big Buck Wrap Pad



- The adjustability of the hook and loop wrap pad, the increased surface area of the Big Buck pad and a Dri-lex lining

P/N 9702-37174 3202C For Titanium & Steel Climbers
P/N 9706-01117 32021C For Aluminum Climber

3118 Big Buck Leather Climber Pad



- Utilizes a double strap system, that fits 1" and 1 1/4" straps, to secure the pad to the calf for superior support
- Angled metal insert keeps climber shank from shifting on calf and thick felt padding adds to the overall comfort
- Includes a pair of 2639 straps but requires two pairs
- Measures 9" H x 12 1/2" W

P/N 9000-70181 3118
P/N 9706-01120 31181 For Aluminum Climber
P/N 9701-81322 2639 Nylon Straps

3500C The Original Velcro® Wrap Pad with Cinch Loop



- A Velcro® pad that features a cinch loop
- No metal insert
- Measures 4" W with 3/4" padding
- Rolled edge to prevent chafing
- Stitched tunnel for a secure fit
- Cinch loop provides tight fit

P/N 9700-58105 3500C

3120 Leather Climber Pad



- A quality leather pad with 3 loops and a tunnel design to keep climber stationary
- All leather construction with 3/4" padding

P/N 9701-34328 3120
P/N 9701-81322 2639 Nylon Straps

3126 Leather Climber Pad



- A comfortable 'L' pad that features a closed cell foam filler that prevents the climber shank from irritating the user's leg
- The rolled edges prevent chafing to the calf muscle
- A slightly heavier pad that provides maximum comfort
- Requires a 26" strap

P/N 9701-89044 3126
P/N 9701-81322 2639 Nylon Straps

2639 - Nylon Leg Strap



1" W x 26" L
P/N 9701-81322 2639



OX BLOCK™ EASE THE LOAD

OVERVIEW

The new Buckingham OX BLOCK™ is a rope snatch block with an integrated friction bar used for hurt man rescue, lowering loads, snubbing loads, and raising loads. It allows the rigging professional to handle loads with greater control. When lowering loads, tension is transferred from the worker to the OX BLOCK™. The OX BLOCK™ replaces standard handline blocks, parted blocks, and various snatch blocks. The OX BLOCK™ also has greater Working Load Limits than blocks of similar size.

MODEL 50061
PATENT PENDING



WLL Eye to Sheave: 2500 lbs...
WLL Eye to Friction Bar: 1500 lbs...

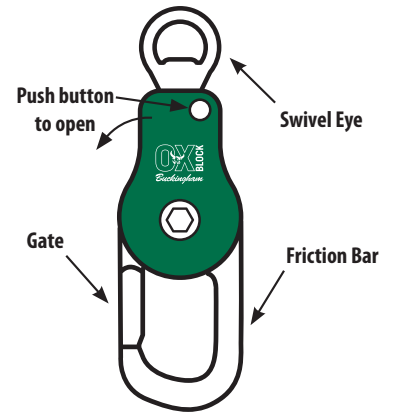

P/N 9705-16691
MODEL 50061A-4



P/N 9705-16691 50061A-4: OX BLOCK™ with an attached 4' x 5/8" adjustable sling and a steel carabiner
P/N 9705-16692 50061A-7: OX BLOCK™ with an attached 7' x 5/8" adjustable sling and a steel carabiner
P/N 9705-16690 50061B: OX BLOCK™ only with 2 steel carabiners

MODEL 50061A-4/80

- The OX Block™ Handline Assembly with an attached 4' x 5/8" adjustable sling, a steel carabiner and an 80' x 1/2" handline assembly.
- The OX Block™ handline assembly, as a whole, can be used during pole top rescue
- DO NOT USE P/N 2406 handline hook [MBS 500 lbs.] or handline snap [MBS 750 lbs.] for human support
- All components used for rescue must have a 5000 lb. rating, configured to accept human support
- For rigging, ensure the weak link has a 5-to-1 safety factor



P/N 9705-16693 50061A-4/80: OX BLOCK™ with attached 4' x 5/8" adjustable sling, a steel carabiner, 80' x 1/2" handline assembly*
P/N 9705-16694 50061A-4/100: OX BLOCK™ with attached 4' x 5/8" adjustable sling, a steel carabiner, 100' x 1/2" handline assembly*
P/N 9705-16695 50061A-7/80: OX BLOCK™ with attached 7' x 5/8" adjustable sling, a steel carabiner, 80' x 1/2" handline assembly*
P/N 9705-16696 50061A-7/100: OX BLOCK™ with attached 7' x 5/8" adjustable sling, a steel carabiner, 100' x 1/2" handline assembly*

PERSONAL EQUIPMENT

USA: 1-877-GO ALTEC
(1-877-462-5832)

www.alteconnect.com

Please call 1-877-GO ALTEC (1-877-462-5832) for additional quality Buckingham Mfg. products.

CONFIGURATIONS

Figure 1:
Common

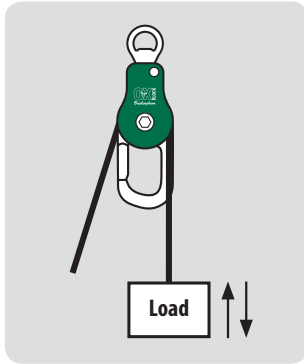

Figure 2:
Hurt Man Rescue
& Lowering Load With Friction

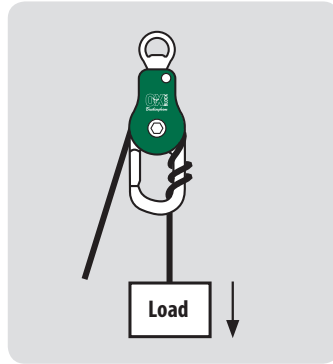

Figure 3:
Snubbing Load

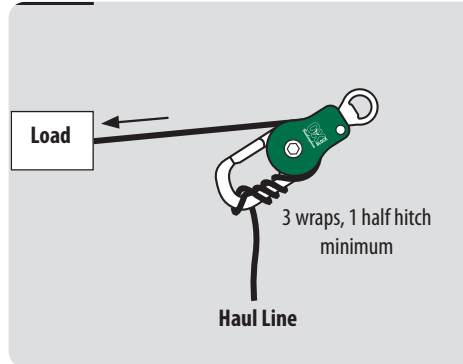
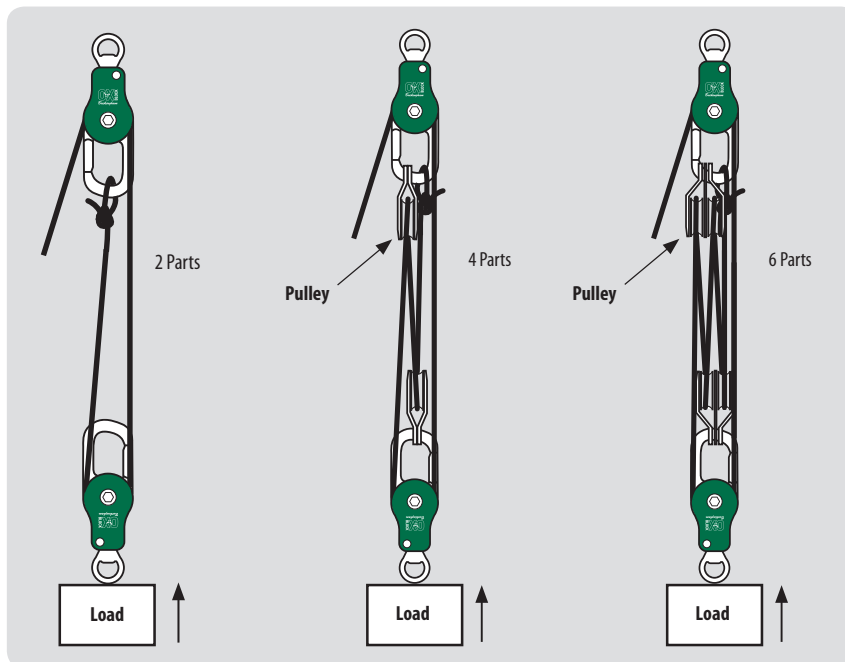

Figure 4:
Raising Load



When configured with optional pulleys, the OX BLOCK™ can be used to create a 4:1, 5:1 or 6:1 mechanical advantage reducing the amount of force needed to lift heavy loads. The advantage of the pulleys used by Buckingham is the swivel side plate that allows for quick and easy rope installation without removing pulley from the connecting device.



P/N 9705-16697

MODEL 5007R1:
Single sheave pulley with swivel eye. 1/2" rope capacity. WLL: 1800 lbs.

P/N 9705-16698

MODEL 5007R2:
Double sheave pulley with swivel eye. 1/2" rope capacity. WLL: 1800 lbs.

OX BLOCK™ ACCESSORIES



P/N 9705-14805
MODEL 39078TAG1-4

P/N 9705-14805 39078TAG1-4: 4' x 5/8" adjustable sling
P/N 9705-16699 39078TAG1-7: 7' x 5/8" adjustable sling
WLL: Straight 3200 lbs.
Choker 2560 lbs.
Basket 6400 lbs.



P/N 9705-38195
MODEL 5005S3: Steel triple action carabiner. Meets ANSI Z359.12 standards. MBS 11,240 lbs.

NOTE: If ordering adjustable sling separately, two carabiners are required for proper loading (see above).

Please call 1-877-GO ALTEC (1-877-462-5832) for additional quality Buckingham Mfg. products.

Hurt Man Bucket Truck Rescue System



- Ideal for lifting a hurt man easily and quickly
- Pulleys are made of stainless steel and have a 4:1 lifting advantage
- 95' of 7/16" diameter rope that can support a load up to 1700 lbs.
- Designed to mount permanently and high up on the boom

P/N 9000-99605 3813

Buck Ladder Lock System

- A ladder safety solution
- Includes ladder safety straps enclosed in weather resistant bags that are attached to your ladder
- Provides quick access to straps
- Includes top and bottom storage bags and straps

P/N 9702-08462 355BT



Suspension Trauma Rescue System



- Designed to alleviate the effects of orthostatic intolerance known as suspension trauma
- Allows a victim to deploy a body support system that allows for improved blood circulation and the ability to move and flex muscles until rescue
- Attaches to any full body harness
- Adjustable for any sized user

P/N 9700-85515 105RS **Standard Version**
P/N 9706-40783 105RSK1 **Arc Flash Rated Version**



High Elevation Self Rescue System

- Provides all components necessary for self-rescue or aiding in rescuing a fellow employee
- The descender stops the user until the handle is compressed allowing for a smooth, controlled descent; also stops if the handle is compressed too hard (50' 1/2" braided rope)

P/N 9000-10150 101SR-50

Buck Self-Rescue System

- Ideal for the one man crew!
- Provides the means to safely and easily descend to the ground in the event of a fall from the bucket or the need to evacuate an inoperable bucket
- Combines a specially designed bag that, when deployed, releases a ladder, an ascender, descender and 50' of rope

P/N 9702-08468 106-50



126R BuckIt Restraint System

Buckingham has developed a bucket restraint system to address the concern of the OSHA compliance officers allowing a full body harness and 6 foot lanyard to fall from the basket and hit an object below. This unit keeps the user secure in the bucket, while allowing freedom to move and work. In the event of a flash, the BuckIt restraint system allows the user to duck to the inside of the bucket for safety.

System Concept:

- A 10,000 lb. rated nylon strap attached, with a ratchet buckle and cotter pin that places the anchor point at the basket
- Two attachment points that attach to a work belt with floating dee rings allows freedom of movement while working. In addition, an energy absorber is attached between the Buck-it Restraint strap and the anchor point on the boom. This unique feature will keep the operator, the basket and the boom from hitting the ground in the event of a catastrophic separation of the bucket from the boom.

Should the webbing around the basket be severed, the attachment back to the anchor is independent of the webbing around the basket.



P/N 9706-25115 126K BuckIt Restraint System

Self Rescue System



Model 301SR - Self Rescue System*

- Features a new lightweight, compact design
- The lightweight descender is manufactured from aircraft grade aluminum and features an anti-panic release brake which will stop the descender if the user releases or compresses the descender all the way
- TVAC descent line measures 6.8mm and is compact and stands up to heat on long descents
- Weather-resistant nylon bag with a mesh bottom lets moisture escape
- Meets ANSI Z359.4 - 2007

P/N 9703-57775 301SR-50 for 50' 37' and 40' Truck Self Rescue Kit, 50' of Rope

P/N 9703-57777 301SR-65 for 65' 55' Truck Self Rescue Kit, 65' of Rope

P/N 9703-57782 301SR-110 for 110' 100' Truck Self Rescue Kit, 110' of Rope

P/N 9703-57786 301SR-160 for 160' 150' Truck Self Rescue Kit, 160' of Rope

* Custom lengths available upon request.



Tower Rescue Blocks

Model 3816L - Tower Rescue Blocks

- New and improved lightweight tower rescue system
- Features a lightweight 3/8" line and a specially designed prusik that automatically locks when the line is released
- The 4-to-1 mechanical advantage allows a victim to be easily raised or lowered in the event of an injury
- System includes an anchor sling and micro grab that can be attached to a lifeline
- 10' Lifting Height
- Weighs 3.75 lbs.

P/N 9706-37185 3816L



8VV16SI+Z Buckyard Shock-Absorbing Lanyard



- For use with a full body harness with steel ring dorsal attachment
- Expands to 42". Interior materials stretch to reduce the arresting force to less than 900 lbs.
- 17061 locking snap hook on both ends
- Length-6ft.
- Meets ANSI Z359.1-2007 for a 3600 lb. gate

P/N 9000-99600 8VV16SI+Z

5V67AQ1 Buck ComboYard



- 5' dual tie-back lanyard with wear guard and rescue loops and 12 foot fall ANSI rated shock absorber
- Tie Back Snaps have a 5000 lb. rated gate that can be used in multiple applications.
- Two ANSI rated Big BuckSnaps Rescue loops aid in quick, easy rescue without putting another person in danger. Tie Back Snaps can be attached to the eye of the ANSI rated Big BuckSnaps, and be directly over tower lattice

P/N 9704-93793 5V67AQ1

6008K-74+Y+Y+Z BuckLimiter



- Aluminum Alloy Construction Inside & Out; a corrosion resistant alloy
- Tangle free swivel top for added mobility
- 7' extension for expanded work area
- Dyneema® polymer fiber 1" webbing - up to 15x stronger than steel. Resistant to moisture, abrasions, UV light and chemicals
- A braking system designed for smooth consistent operation to prevent "jerky" lock-ups
- No factory recertification required
- Retractable unit (no hardware) only weighs 1.9lbs.
- Rated to 350 lbs.
- Triple Lock Aluminum Carabiner with a 3600 lb. gate on each end

P/N 9703-53164 6008K-74+Y+Y+Z

6393700 - 'H' Style Full Body Harness



- An 'H' style full body harness featuring a web dorsal loop attachment
- Hook and loop chest strap that meets ANSI Z359.1 requirements
- Interlocking leg strap buckles with leather chafes
- Standard friction buckle for height adjustment
- Made from Type 13 nylon webbing

with orange upper and black lower sections.

- Meets ASTM F887 Electric Arc Performance Requirements.

P/N 704-20871 6393700-L Large

KIT: P/N 9000-88845 - Includes (1) 704-20871 Large Harness and (1) P/N 704-20872 (84V716) 6' Length Buckyard Stretch Lanyard

84V716SI+Z Buckyard Stretch Shock-Absorbing Lanyard



- Same benefits of the Buckyard but with the addition of an elastic bungee; this reduces the size of a 6' lanyard to about 44" - greatly reducing the chance of tripping over it

- For full body harness w/web loop dorsal attachment
- 1706 locking snap hook on one end and web loop on the other end

P/N 9706-07992 84V716SI+Z 6' Length

Ergovation® Tower Harness



- Ergonomic, lightweight "Y" style harness offers the ability to adjust the fit of the belt and the harness separately
- Features 2 in-line dees, a rope bridge that allows the user to comfortably and ergonomically sit for suspension work
- Suspension connection splits the user's weight between the legs and back so the entire amount of weight isn't focused on the back

- May be used as a connection point for work positioning
- Y style harness design articulates over the shoulders allowing greater ability for user to move and not be restricted

P/N 9706-37186 17907-M Medium

P/N 9706-37187 17907-L Large

BuckFit Harness



'H' Style Full Body Harness with Web Dorsal Loop

- Buck Mini Back Pad harness offers comfort and ease in donning
- Features shoulder pads made from sateen fabric with fire resistant padding
- Harness features back straps with male end aluminum interlocking buckles to connect to the Buck ErgoBelt, patented quick connect

buckles at the chest strap and leg pads, vertical shoulder adjustment, and leather chafes behind the leg quick connect buckles (for comfort and to reduce the potential of static charge)

- Harness features a 5000 lb rated nylon dorsal loop that eliminates metal and allows user to girth hitch their shock absorber (can be ordered with a dorsal dee)

- Meets ASTM F887 Electric Arc Performance performance

P/N 9705-31142 68D98C74C0K4-L Large

P/N 9706-37188 68D98C74C0K4-X X-Large

BuckFit FR Harness



- Steel Dorsal Dee. 'H' style full body harness
- Mesh shell for breathe-ability. FR foam pads.
- Split tongue quick connect with leather chafes on the legs and chest straps
- ASTM F887 and ANSI approved
- Spring loaded friction buckles for height adjustment

- Meets ASTM F887 Electric Arc Performance Requirements

P/N 9702-57015 68D7G8C600K1-L Large

P/N 9700-74188 68D7G8C600K1-XL X-Large

Please call 1-877-GO ALTEC (1-877-462-5832) for additional quality Buckingham Mfg. products.

Gear Bucket Haul Bag



- Constructed of 44oz. Vinyl
- 4300 cubic inches of internal storage, built to withstand the most abusive environments and treatment
- Measures 13"Dia x 27"H
- An ergonomic back pad that easily removes for travel or storage
- Climbing spec webbing used to reinforce all seams and wear points
- Metal buckles and snaps, that will far outlast plastic components
- 2 large grommets on underside used for drain holes, or to run rope out of bottom
- MOLLE webbing on exterior and interior of bag for organizing and racking gear
- Fits 200" of rope

P/N 9703-58630 4370B14 - Gear Bucket Haul Bag

Buckingham 52993 - Leather Nut & Bolt Bag



- Three inside pockets for speed wrenches
- Available in Brown, Black & Burgundy
- Measures 10 1/4" x 10"

P/N 9701-51532 52993BR Brown
P/N 9701-15899 52993BL Black

Camouflage Canvas Bag



- 6" diameter heavy duty rubber wheels
- Ideal for transporting equipment in rough terrain
- Push button handle retracts when not in use

P/N 9703-61916 Model 41333C7R5W3

7091 Buck ErgoBlade Knife

- A Revolutionary Lineman's Skinning Knife!
- 1 1/4" diameter rubber handle fits comfortably in a gloved hand
- Round handle allows the user to create the proper cutting angle by rotating the knife within the hand instead of constantly, and repetitively, turning the wrist
- 5 3/4" long handle extends beyond the palm reducing the force and wrist action needed to secure the knife while skinning cable
- Textured rubber handle increases gripping while working in inclement weather



P/N 9703-58605 7091



P/N 9705-95486 7091G

Rope Pail Haul Bag



- Constructed of 44oz. Vinyl
- Designed for the Arborist, Tower Worker, or Rope Access Technician, who has to haul their rope around and needs to pack it quickly and conveniently while keeping pace on the vertical jobsite
- Measures 6" x 11" oval x 19"H
- Fits 200" of 1/2" climbing line
- Ergonomic back pad that easily removes for travel or storage
- Climbing spec webbing used to reinforce all seams and wear points
- Metal buckles and snaps, that will far outlast plastic components
- 1 large grommet on underside used as a drain hole, or to run rope out of bottom of bag
- MOLLE webbing exterior and interior of bag for organization and racking gear.

P/N 9703-58608 4371B14 - Rope Pail Haul Bag

Buckingham 45911M2 - Canvas Nut & Bolt Bag



- Canvas bag built with an inside pocket for organizing spare parts
- Web loops are strategically positioned to store cotter pins during work
- Features a powerful magnet,
- Reinforced bottom to prevent premature wear
- Measures 3"H x 8"W x 9"L

P/N 9702-54260 45911M2

42666-BL Holster



- 5 pockets
- 10 3/4" x 8"
- 2 way knife snap
- 4089 knife sheath attached

P/N 9702-44431 42666-BL

Hydra-Cool™ Climber System

PERSONAL EQUIPMENT

USA: 1-877-GO ALTEC
(1-877-462-5832)

www.alteconnect.com



Featuring exclusive bi-layer climber pads for superior comfort and support

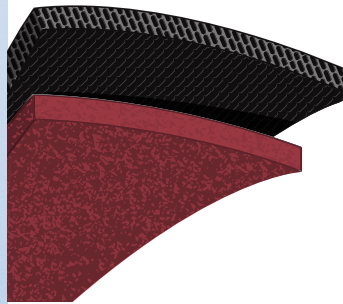

- Top Layer:** Moisture-wicking with both cooling and thermal insulating properties
- Bottom Layer:** PORON® Cushioning, absorbs impact, resists water, and conforms to leg for comfort

- Protective polyurethane-coated leather resists weathering, water absorption, and cracking
- One size fits most, sold in pairs, includes metal insert and Velcro® strap closure



9705-95349



9705-95340



9705-95336

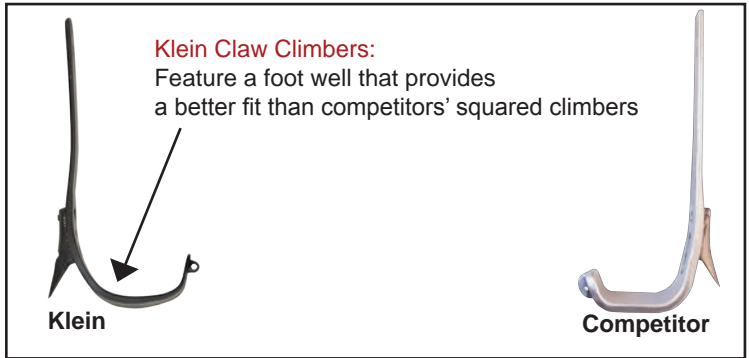

Klein Claw Climbers:
Feature a foot well that provides a better fit than competitors' squared climbers

Klein

Competitor

Part Number	Klein
P/N 9705-95336	2214
P/N 9705-95340	2214ARS
P/N 9705-95349	221486
P/N 9705-95350	1907AR
P/N 9705-95355	221407

Size	Description
	Hydra-Cool™ Climber Pads
	Klein Claw Pole Climbers - Climbers, Claw Gaffs and Ankle Straps
	Hydra-Cool™ Pole Climber System - Pads, Climbers, Claw Gaffs & Straps
	Tree Climbers with #07 Gaffs
	Hydra-Cool™ Tree Climbing System - Pads, Climbers, #07 Gaffs & Ankle Straps

Positioning Strap

- Internal lock mechanism
- Elongated 6 1/2" snap hook is easy to use with even the thickest gloves and has a 5,000 lb. proof-loaded rating
- 6-ply, 1 3/4" wide Klein-Kord®
- Meets or exceeds OSHA requirements and ASTM and CSA standards
- Red wear indicator alerts user when strap needs to be replaced



Part Number	Klein	Size
P/N 9701-58715	KG5295L	5'8"
P/N 9701-58716	KG5295-6L	6'
P/N 9701-58717	KG5295-6-6L	6'6"
P/N 9701-58718	KG5295-7L	7'
P/N 9701-58720	KG5295-8L	8'



Snap-On Gaff Guard

- Coil-spring, plastic coated guard quickly snaps onto pole climbers
- Sold in pairs only

P/N 9000-01972 Klein 1972G



Removable Gaff Guard

- Long-lasting leather construction with genuine VELCRO® brand touch fastener strap
- Sold in pairs only

P/N 9701-28002 Klein 1945G

Ankle Straps for Pole and Tree Climbers



- Durable neoprene-impregnated nylon strap is chemical/abrasion resistant and non-conductive
- Tongue buckle has roller for easy adjustment and a comfortable leather buckle pad
- Sold in pairs only

P/N 9000-53020 Klein 5301-20

Climber Straps for Pole and Tree Climbers



- Durable neoprene-impregnated nylon strap is chemical/abrasion resistant and non-conductive
- Tongue buckle has roller for easy adjustment and a comfortable leather buckle pad
- Sold in pairs only

P/N 8001-00017 Klein 5301-18

BULWARK COMFORT SERIES

The World's Largest Manufacturer and Industry Leader of Flame-Resistant Apparel

Bulwark Brand Labels on all FR clothing guarantees flame resistant for the life of the garment!



PERSONAL EQUIPMENT

USA: 1-877-GO ALTEC
(1-877-462-5832)

www.alteconnect.com

No Compromise iQ T-SHIRT

Rib knit collar, raglan sleeves, Full sideseam gusset and chest pocket with pencil stall, contrasting thread color, and iQ SERIES™ seam tag.

Fabric: Flame-resistant, 5.3 oz. (180 g / m2)
69% Cotton/25% Polyester/6% Polyoxadiazole
Protection: Arc Rating ATPV 8.2 calories / cm2
Colors: Black (BK), Blue (BL), Charcoal (CH),
Dark Blue (DB), Red (RD), Tan (TN)

CHARCOAL iQ LONG SLEEVE T-SHIRT

P/N 9705-67209	QT32-CH-M	Charcoal
P/N 9705-67210	QT32-CH-L	Charcoal
P/N 9705-67211	QT32-CH-XL	Charcoal
P/N 9705-67212	QT32-CH-2XL	Charcoal
P/N 9705-67213	QT32-CH-3XL	Charcoal
P/N 9705-67214	QT32-CH-4XL	Charcoal

TAN iQ LONG SLEEVE T-SHIRT

P/N 9705-67215	QT32-TN-M	Tan
P/N 9705-67216	QT32-TN-L	Tan
P/N 9705-67217	QT32-TN-XL	Tan
P/N 9705-67218	QT32-TN-2XL	Tan
P/N 9705-67219	QT32-TN-3XL	Tan
P/N 9705-67220	QT32-TN-4XL	Tan



iQ POLO

Zipper front placket, self fabric collar and raglan sleeves. chest pocket with pencil stall, Pencil stall, pocket on right sleeve, contrasting thread color, and iQ SERIES™ seam tag.

Full side seam gusset
Concealed rib knit cuffs
Fabric: Flame-resistant, 5.3 oz. (180 g/m2)
69% Cotton/25% Polyester/6% Polyoxadiazole
Protection: Arc Rating ATPV 8.2 calories/cm2
Colors: Black (BK), Blue (BL), Charcoal (CH),
Dark Blue (DB), Red (RD), Tan (TN)

TAN iQ LONG SLEEVE T-SHIRT

P/N 9705-67221	QT12-TN-M	Tan
P/N 9705-67222	QT12-TN-L	Tan
P/N 9705-67223	QT12-TN-XL	Tan
P/N 9705-67224	QT12-TN-2XL	Tan
P/N 9705-67225	QT12-TN-3XL	Tan
P/N 9705-67226	QT12-TN-4XL	Tan

DARK BLUE iQ LONG SLEEVE T-SHIRT

P/N 9705-67227	QT12-DB-M	Dark Blue
P/N 9705-67228	QT12-DB-L	Dark Blue
P/N 9705-67229	QT12-DB-XL	Dark Blue
P/N 9705-67230	QT12-DB-2XL	Dark Blue
P/N 9705-67231	QT12-DB-3XL	Dark Blue
P/N 9705-67232	QT12-DB-4XL	Dark Blue

iQ HENLEY

FOUR-button placket, rib knit henley collar, contrasting thread color and raglan sleeves. Concealed rib knit cuffs, full sideseam gusset. chest pocket with pencil stall, pencil stall pocket on right sleeve, and iQ series™ seam tag.

Full side seam gusset
Concealed rib knit cuffs
Fabric: Flame-resistant, 5.3 oz. (180 g/m2)
69% Cotton/25% Polyester/6% Polyoxadiazole
Protection: Arc Rating ATPV 8.2 calories/cm2
Colors: Black (BK), Blue (BL), Charcoal (CH),
Dark Blue (DB), Red (RD), Tan (TN)

CHARCOAL iQ LONG SLEEVE T-SHIRT

P/N 9705-51326	QT20-CH-M	Charcoal
P/N 9705-51343	QT20-CH-L	Charcoal
P/N 9705-51344	QT20-CH-XL	Charcoal
P/N 9705-51345	QT20-CH-2XL	Charcoal
P/N 9705-51346	QT20-CH-3XL	Charcoal
P/N 9705-51347	QT20-CH-4XL	Charcoal

DARK BLUE iQ LONG SLEEVE T-SHIRT

P/N 9705-51348	QT20-DB-M	Dark Blue
P/N 9705-51350	QT20-DB-L	Dark Blue
P/N 9705-51351	QT20-DB-XL	Dark Blue
P/N 9705-51352	QT20-DB-2XL	Dark Blue
P/N 9705-51353	QT20-DB-3XL	Dark Blue
P/N 9705-51354	QT20-DB-4XL	Dark Blue





HENLEY SHIRTS



No Compromise

Three-button placket
 Dyed to match rib knit henley collar and cuffs
 Raglan sleeves. Spade style chest pocket
 Fabric is moisture wicking and breathable
 Full side seam gusset
 Concealed rib knit cuffs
 Fabric: Flame-resistant, 6.5 oz. (220 g / m2)
 45% Modacrylic / 35% Lyocell / 20% Aramid
 Protection: Arc Rating EBT 8.2 calories / cm²
 Colors: Grey (GY), Khaki (KH), Navy (NV)

	GREY SML2-GY	KHAKI SML2-KH	NAVY SML2-NV
Medium	9705-67233	9705-67241	9705-67249
Large	9705-67234	9705-67242	9705-67250
X-Large	9705-67235	9705-67243	9705-67251
2X-Large	9705-67236	9705-67244	9705-67252
3X-Large	9705-67237	9705-67245	9705-67253
Large - Long	9705-67238	9705-67246	9705-67254
X-Large - Long	9705-67239	9705-67247	9705-67255
2X-Large - Long	9705-67240	9705-67248	9705-67256

CLASSIC POLO

Three-button placket. Dyed to match rib knit collar. Long sleeve polo has dyed to match rib knit cuffs. Short sleeve polo has hemmed sleeves. Raglan sleeves. Sleeve pocket. Fabric is moisture wicking and breathable.

Fabric: Flame-resistant, 6.5 oz. (220 g / m2)
 45% Modacrylic / 35% Lyocell / 20% Aramid
 Protection: Arc Rating EBT 8.2 calories/cm²
 Colors: Grey (GY), Khaki (KH), Navy (NV)

	KHAKI SMP2-KH	NAVY SLP2-NV
Medium	9705-67257	9705-67265
Large	9705-67258	9705-67266
X-Large	9705-67259	9705-67267
2X-Large	9705-67260	9705-67268
3X-Large	9705-67261	9705-67269
Large - Long	9705-67262	9705-67270
X-Large - Long	9705-67263	9705-67271
2X-Large - Long	9705-67264	9705-67272



CLASSIC POLO



Three-button placket.
 Dyed to match rib knit collar
 Long sleeve polo has dyed to match rib knit cuffs
 Short sleeve polo has hemmed sleeves
 Raglan sleeves. Sleeve pocket. Fabric is moisture wicking and breathable
 Colors: Grey (GY), Khaki (KH), Navy (NV)

	KHAKI SMP8-KH	NAVY SLP8-NV
Medium	9705-67273	9705-67281
Large	9705-67274	9705-67282
X-Large	9705-67275	9705-67283
2X-Large	9705-67276	9705-67284
3X-Large	9705-67277	9705-67285
Large - Long	9705-67278	9705-67286
X-Large - Long	9705-67279	9705-67287
2X-Large - Long	9705-67280	9705-67288

Please contact your Altec Supply Account Manager or call 1-877-GO ALTEC (1-877-462-5832) for more information regarding quality Bulwark products.

PERSONAL EQUIPMENT

USA: 1-877-GO ALTEC
 (1-877-462-5832)

www.alteconnect.com



BULWARK COMFORT SERIES

The World's Largest Manufacturer and Industry Leader of Flame-Resistant Apparel

Bulwark Brand Labels on all FR clothing guarantees flame resistant for the life of the garment!

PERSONAL EQUIPMENT

USA: 1-877-GO ALTEC
(1-877-462-5832)

www.alteconnect.com

No Compromise

LONG SLEEVE PERFORMANCE T-SHIRT

Rib-knit crew neck style, Collar and cuffs, Full sideseam gusset with raglan sleeves

Fabric is moisture wicking and breathable

Fabric: Flame-resistant, 6.5 oz. (220 g / m²) 45%

Modacrylic / 35% Lyocell / 20% Aramid

Protection: Arc Rating ATPV 8.1 calories / cm²

Colors: Grey (GY), Khaki (KH), Navy (NV)

	GREY	KHAKI	NAVY
	SMT2-GY	SMT2-KH	SMT2-NV
Medium	9705-67289	9705-67297	9705-67305
Large	9705-67290	9705-67298	9705-67306
X-Large	9705-67291	9705-67299	9705-67307
2X-Large	9705-67292	9705-67300	9705-67308
3X-Large	9705-67293	9705-67301	9705-67309
Large - Long	9705-67294	9705-67302	9705-67310
X-Large - Long	9705-67295	9705-67303	9705-67311
2X-Large - Long	9705-67296	9705-67304	9705-67312



LONG SLEEVE TAGLESS HENLEY SHIRT

sel2 - Men's (Reg) S-4XL. (Long) L-2XL.

Three-button placket. Rib knit henley collar. Rib knit cuffs.

Tagless brand label and warning label.

Fabric: Flame-resistant, 7.25 oz. (210 g / m²) Interlock FR, 100% Cotton

Protection: Arc Rating ATPV 9.6 calories / cm²

Colors: Grey (GY), Khaki (KH), Light Blue (LB), Navy (NV), Orange (OR)

R (GYR), (KHR), (LBR), (NVR), (ORR)

	ORANGE	KHAKI	NAVY	GREY
	SEL2-OR	SEL2-KH	SEL2-NV	SEL2-GY
Small	9705-67313	9703-45838	9700-98667	9703-45828
Medium	9700-98672	9703-45837	9703-45847	9703-45827
Large	9700-98673	9703-45836	9700-98669	9703-45826
X-Large	9700-98674	9703-45839	9700-98670	9703-45829
2X-Large	9703-46684	9703-45840	9701-10947	9701-52157
3X-Large	9703-45854	9703-45834	9701-27686	9703-45824
4X-Large	9703-45855	9703-45835	9700-98663	9703-45830
Large - Long	9703-45851	9703-45831	9703-45841	9703-45821
X-Large - Long	9703-45852	9703-45832	9703-45842	9703-45822
2X-Large - Long	9703-45853	9703-45833	9703-45843	9703-45823



TAGLESS T-SHIRTS

SET8 - Men's Short Sleeve (Reg) S-4XL. (Long) L-22X11L2 .NFPA

Rib knit crewneck-style collar and hemmed sleeves.

Tagless brand label and warning label.

Fabric: Flame-resistant, 7.25 oz. (210 g / m²) Interlock FR, 100% Cotton

Protection: Arc Rating ATPV 9.6 calories / cm²

Colors: Grey (GY), Navy (NV)

	GREY	NAVY
	SET8-GY	SET8-NV
Small	9705-67314	9700-98631
Medium	9705-67315	9700-98638
Large	9700-98626	9700-98646
X-Large	9702-58993	9700-98649
2X-Large	9701-09828	9701-10946
3X-Large	9705-67316	9701-27681
4X-Large	9705-67317	9705-67321
Large - Long	9705-67318	9705-67322
X-Large - Long	9705-67319	9705-67323
2X-Large - Long	9705-67320	9705-67324





6 OZ. UNIFORM SHIRT

SLU8 - Men's (Reg) S-3XL. (Long) M-3XL.

Full side seam gusset.

Fabric: Flame-resistant, 6 oz. (205 g / m²); 88% Cotton / 12% Nylon

Protection: Arc Rating ATPV 8.7 calories / cm²

Colors: Grey (GY), Khaki (KH), Light Blue (LB), Navy (NV), Orange (OR)

	KHAKI SLU8-KH	LIGHT BLUE SLU8-LB	NAVY SLU8-NV	ORANGE SLU8-OR
Small	9705-67325	9705-67328	9705-67330	9705-67333
Medium	9703-45794	9703-45802	9703-46178	9703-45818
Large	9703-45793	9703-45801	9703-46179	9703-45817
X-Large	9703-45795	9703-45803	9703-46180	9703-45819
2X-Large	9703-45796	9703-45804	9703-46181	9703-45820
3X-Large	9703-45792	9703-45800	9703-46182	9703-45816
Medium - Long	9705-67326	9705-67329	9705-67331	9705-67334
Large - Long	9703-45789	9703-45797	9703-46183	9703-45813
X-Large - Long	9703-45790	9703-45798	9703-46184	9703-45814
2X-Large - Long	9703-45791	9703-45799	9703-46185	9703-45815
3X-Large - Long	9705-67327	9703-45800	9705-67332	9705-67335

7 OZ. WORK SHIRT

SLW2 - Men's (Reg) S-3XL. (Long) M-3XL. Full side seam gusset.

Fabric: Flame-resistant, 7 oz. (235 g / m²) 88% Cotton / 12% Nylon

Protection: Arc Rating ATPV 8.6 calories / cm²

Colors: Khaki (KH), Light Blue (LB), Navy (NV)

	KHAKI SLW2-KH	LIGHT BLUE SLW2-LB	NAVY SLW2-NV
Small	9705-67336	9705-67345	9705-67356
Medium	9705-67337	9705-67346	9705-67357
Large	9703-41959	9705-67347	9703-41985
X-Large	9703-41975	9705-67348	9702-69647
2X-Large	9705-67338	9705-67349	9705-67360
3X-Large	9705-67339	9705-67350	9705-67361
Medium - Long	9705-67340	9705-67351	9705-67362
Large - Long	9705-67341	9705-67352	9705-67363
X-Large - Long	9705-67342	9705-67353	9705-67364
2X-Large - Long	9705-67343	9705-67354	9705-67365
3X-Large - Long	9705-67344	9705-67355	9705-67366



7 OZ. DRESS UNIFORM SHIRT

SMU2 (shown left) - Men's (Reg) S-3XL. (Long) M-3XL. Full side seam gusset.

Fabric (Khaki, Light Blue): Flame-resistant, 7 oz. (235 g / m²) 48% Modacrylic / 37% Lyocell / 15% Aramid

Fabric (Navy): Flame-resistant, 7 oz. (235 g / m²) 45% Modacrylic / 35% Lyocell / 20% Aramid

Protection (Khaki, Light Blue): Arc Rating ATPV 9.0 calories/cm² (Navy): Arc Rating ATPV 10.1 calories/cm²

Colors: Khaki (KH), Light Blue (LB), Navy (NV)

	KHAKI SMU2-KH	LIGHT BLUE SMU2-LB	NAVY SMU2-NV
Small	9705-67367	9705-67378	9705-67389
Medium	9705-67368	9705-67379	9705-67390
Large	9705-67369	9705-67380	9705-67391
X-Large	9705-67370	9705-67381	9702-87546
2X-Large	9705-67371	9705-67382	9705-67392
3X-Large	9705-67372	9705-67383	9705-67393
Medium - Long	9705-67373	9705-67384	9705-67394
Large - Long	9705-67374	9705-67385	9705-67395
X-Large - Long	9705-67375	9705-67386	9705-67396
2X-Large - Long	9705-67376	9705-67387	9705-67397
3X-Large - Long	9705-67377	9705-67388	9705-67398



6.5 OZ. DRESS UNIFORM SHIRT

SLG 8 - Men's (Reg) S-3XL. (Long) M-3XL. Full side seam gusset.

Fabric: Flame-resistant, 6.5 oz. (220 g / m²); 88% Cotton / 12% Nylon

Protection: Arc Rating ATPV 8.7 calories / cm²

Colors: Red / Navy (RN), Navy / Khaki (NK),

Hunter / Navy (HN), Red / Khaki (RK)

Size	Hunter/Navy (SLG8-HN)	Navy/Khaki (SLG8-NK)	Red/Khaki (SLG8-RK)	Red/Navy (SLG8-RN)
Small	9703-46210	9703-46221	9703-46232	9703-46243
Medium	9703-46211	9703-46222	9703-46233	9703-46244
Large	9703-46212	9703-46223	9703-46234	9703-46245
X-Large	9703-46213	9703-46224	9703-46235	9703-46246
2X-Large	9703-46214	9703-46225	9703-46236	9703-46247
3X-Large	9703-46215	9703-46226	9703-46237	9703-46248
Medium - Long	9703-46216	9703-46227	9703-46238	9703-46249
Large - Long	9703-46217	9703-46228	9703-46239	9703-46250
X-Large - Long	9703-46218	9703-46229	9703-46240	9703-46251
2X-Large - Long	9703-46219	9703-46230	9703-46241	9703-46252
3X-Large - Long	9703-46220	9703-46231	9703-46242	9703-46253



No Compromise

PERSONAL EQUIPMENT

USA: 1-877-GO ALTEC
(1-877-462-5832)

www.alteconnect.com

BULWARK COMFORT SERIES

The World's Largest Manufacturer and Industry Leader of Flame-Resistant Apparel



No Compromise

Bulwark Brand Labels on all FR clothing guarantees flame resistant for the life of the garment!

To Order any of the Pants Shown:

Please specify the code below for the particular color you need, then specify your size in a Waist/Length format. For example, to order the PLJ8 Model Brown Duck color in a waist size of 38" and a length of 34", the ordering code would be PLJ8-BD-38/34

LOOSE FIT STONE-WASHED DENIM JEAN

PEJ6 - Men's 28, 30-36, 38-50 Even.

Soft pre-wash and stone-washed fabric for comfort and look.

Fabric: Flame-resistant, 14.75 oz. (500 g / m²) 100% Pre-washed Cotton Denim

Protection: Arc Rating ATPV 20.7 calories / cm²

Color: Stone Wash (SW)

Blue Denim Stone Wash

970345926	PEJ6SW-28/30	970345930	PEJ6SW-33/30	970345934	PEJ6SW-38/30	970345938	PEJ6SW-46/30
970345941	PEJ6SW-28/32	970345945	PEJ6SW-33/32	970345949	PEJ6SW-38/32	970345953	PEJ6SW-46/32
970345956	PEJ6SW-28/34	970345960	PEJ6SW-33/34	970345964	PEJ6SW-38/34	970345968	PEJ6SW-46/34
970345927	PEJ6SW-30/30	970345931	PEJ6SW-34/30	970345935	PEJ6SW-40/30	970345939	PEJ6SW-48/30
970345942	PEJ6SW-30/32	970345946	PEJ6SW-34/32	970345950	PEJ6SW-40/32	970345954	PEJ6SW-48/32
970345957	PEJ6SW-30/34	970345961	PEJ6SW-34/34	970345965	PEJ6SW-40/34	970345969	PEJ6SW-48/34
970345928	PEJ6SW-31/30	970345932	PEJ6SW-35/30	970345936	PEJ6SW-42/30	970345940	PEJ6SW-50/30
970345943	PEJ6SW-31/32	970345947	PEJ6SW-35/32	970345951	PEJ6SW-42/32	970345955	PEJ6SW-50/32
970345958	PEJ6SW-31/34	970345962	PEJ6SW-35/34	970345966	PEJ6SW-42/34	970345970	PEJ6SW-50/34
970345929	PEJ6SW-32/30	970345933	PEJ6SW-36/30	970345937	PEJ6SW-44/30		
970345944	PEJ6SW-32/32	970345948	PEJ6SW-36/32	970345952	PEJ6SW-44/32		
970345959	PEJ6SW-32/34	970345963	PEJ6SW-36/34	970345967	PEJ6SW-44/34		



PRE-WASHED DENIM DUNGAREE

PEJ8 - Men's 28-50 Even.

Two deep scoop pockets. Two oversized reinforced hip pockets. Rule pocket on right leg with wrap around utility pocket. Soft pre-wash for comfort and look.

Fabric: Flame-resistant, 14.75 oz. (500 g / m²) 100% Cotton Denim

Protection: Arc Rating ATPV 20.7 calories / cm²

Colors: Blue Denim (DW), Stone Wash (SW)

Blue Denim Dark Wash

970345971	PEJ8DW-28/30	970345975	PEJ8DW-36/30	970345979	PEJ8DW-44/30
970345983	PEJ8DW-28/32	970345987	PEJ8DW-36/32	970345991	PEJ8DW-44/32
970345995	PEJ8DW-28/34	970345999	PEJ8DW-36/34	970346003	PEJ8DW-44/34
970345972	PEJ8DW-30/30	970345976	PEJ8DW-38/30	970345980	PEJ8DW-46/30
970345984	PEJ8DW-30/32	970345988	PEJ8DW-38/32	970345992	PEJ8DW-46/32
970345996	PEJ8DW-30/34	970346000	PEJ8DW-38/34	970346004	PEJ8DW-46/34
970345973	PEJ8DW-32/30	970345977	PEJ8DW-40/30	970345981	PEJ8DW-48/30
970345985	PEJ8DW-32/32	970345989	PEJ8DW-40/32	970345993	PEJ8DW-48/32
970345997	PEJ8DW-32/34	970346001	PEJ8DW-40/34	970346005	PEJ8DW-48/34
970345974	PEJ8DW-34/30	970345978	PEJ8DW-42/30	970345982	PEJ8DW-50/30
970345986	PEJ8DW-34/32	970345990	PEJ8DW-42/32	970345994	PEJ8DW-50/32
970345998	PEJ8DW-34/34	970346002	PEJ8DW-42/34	970346006	PEJ8DW-50/34

Blue Denim Stone Wash

970346007	PEJ8SW-30/30	970346010	PEJ8SW-38/30	970346014	PEJ8SW-46/30
970346017	PEJ8SW-30/32	970259005	PEJ8SW-38/32	970274147	PEJ8SW-46/32
970264144	PEJ8SW-30/34	970346028	PEJ8SW-38/34	970346032	PEJ8SW-46/34
970346008	PEJ8SW-32/30	970346011	PEJ8SW-40/30	970346015	PEJ8SW-48/30
970346018	PEJ8SW-32/32	970346021	PEJ8SW-40/32	970346024	PEJ8SW-48/32
970346026	PEJ8SW-32/34	970346029	PEJ8SW-40/34	970346033	PEJ8SW-48/34
970346009	PEJ8SW-34/30	970346012	PEJ8SW-42/30	970346016	PEJ8SW-50/30
970346019	PEJ8SW-34/32	970346022	PEJ8SW-42/32	970346025	PEJ8SW-50/32
970346027	PEJ8SW-34/34	970346030	PEJ8SW-42/34	970346034	PEJ8SW-50/34
970264148	PEJ8SW-36/30	970346013	PEJ8SW-44/30		
970346020	PEJ8SW-36/32	970346023	PEJ8SW-44/32		
970259003	PEJ8SW-36/34	970346031	PEJ8SW-44/34		

PEJ8-DW Blue Denim
PEJ8-SW Stone Wash



To order, please call 1-877-GO ALTEC (1-877-462-5832), and specify the model number, waist size and length.

PERSONAL EQUIPMENT

USA: 1-877-GO ALTEC
(1-877-462-5832)

www.alteconnect.com



STRAIGHT FIT SANDED DENIM JEAN



No Compromise



PEJM - Men's 28-50 Even.

One-piece waistband with metal button closure (metal is not exposed to the skin).
New, soft pre-wash and sanded fabric for modern and comfortable look.

Fabric: Flame-resistant, 12.5 oz. (425 g / m²) 100% Pre-washed Cotton Denim

Protection: Arc Rating ATPV 18.0 calories / cm²

Color: Sanded Denim (SD)

PEJM-SD MEN'S SANDED DENIM JEAN

970346262	PEJM-SD-28/30	970346266	PEJM-SD-36/30	970346270	PEJM-SD-44/30
970346274	PEJM-SD-28/32	970346278	PEJM-SD-36/32	970346282	PEJM-SD-44/32
970346286	PEJM-SD-28/34	970346290	PEJM-SD-36/34	970346294	PEJM-SD-44/34
970346263	PEJM-SD-30/30	970346267	PEJM-SD-38/30	970346271	PEJM-SD-46/30
970346275	PEJM-SD-30/32	970346279	PEJM-SD-38/32	970346283	PEJM-SD-46/32
970346287	PEJM-SD-30/34	970346291	PEJM-SD-38/34	970346295	PEJM-SD-46/34
970346264	PEJM-SD-32/30	970346268	PEJM-SD-40/30	970346272	PEJM-SD-48/30
970346276	PEJM-SD-32/32	970346280	PEJM-SD-40/32	970346284	PEJM-SD-48/32
970346288	PEJM-SD-32/34	970346292	PEJM-SD-40/34	970346296	PEJM-SD-48/34
970346265	PEJM-SD-34/30	970346269	PEJM-SD-42/30	970346273	PEJM-SD-50/30
970346277	PEJM-SD-34/32	970346281	PEJM-SD-42/32	970346285	PEJM-SD-50/32
970346289	PEJM-SD-34/34	970346293	PEJM-SD-42/34	970346297	PEJM-SD-50/34

PEJW-SD WOMEN'S SANDED DENIM JEAN

970346301	PEJW-SD-10/30	970346305	PEJW-SD-18/30	970346298	PEJW-SD-4/30
970346312	PEJW-SD-10/32	970346327	PEJW-SD-18/34	970346316	PEJW-SD-18/32
970346323	PEJW-SD-10/34	970346306	PEJW-SD-20/30	970346317	PEJW-SD-20/32
970346302	PEJW-SD-12/30	970346328	PEJW-SD-20/34	970346318	PEJW-SD-22/32
970346313	PEJW-SD-12/32	970346307	PEJW-SD-22/30	970346319	PEJW-SD-24/32
970346324	PEJW-SD-12/34	970346329	PEJW-SD-22/34	970346299	PEJW-SD-6/30
970346314	PEJW-SD-14/32	970346308	PEJW-SD-24/30	970346310	PEJW-SD-6/32
970346325	PEJW-SD-14/34	970346330	PEJW-SD-24/34	970346321	PEJW-SD-6/34
970346304	PEJW-SD-16/30	970346309	PEJW-SD-4/32	970346300	PEJW-SD-8/30
970346315	PEJW-SD-16/32	970346320	PEJW-SD-4/34	970346311	PEJW-SD-8/32
970346326	PEJW-SD-16/34	970346303	PEJW-SD-14/30	970346322	PEJW-SD-8/34

WORK PANTS

PMW2 - Men's 28-50 Even

Waist band with button closure. Two slack-style front pockets. Left hip pocket with button closure.

Fabric: Flame-resistant, 7 oz. (235 g / m²) 45% Modacrylic / 35% Lyocell / 20% Aramid

Protection: Arc Rating ATPV 10.1 calories / cm²

Navy (NV)

To order, please call 1-877-GO ALTEC (1-877-462-5832), and specify the model number, waist size and length.

WORK PANTS

PLW2 - Men's 28-56. 2112

Waist band with button closure. Two slack-style front pockets. Left hip pocket with button closure.

Fabric: Flame-resistant, 9 oz. (305 g / m²) Twill, 88% Cotton / 12% Nylon

Protection: Arc Rating ATPV 12.2 calories / cm²

Colors: Navy (NV), Khaki (KH)

To order, please call 1-877-GO ALTEC (1-877-462-5832), and specify the model number, waist size and length.

CARGO POCKET PANT

PMU2 - Men's 28-36, 38-52 Even.

Waistband with hook-and-bar closure. Two utility pockets. Left cargo pocket has two snap closures. Right utility pocket is open.

Fabric: Flame-resistant, 7 oz. (235 g / m²) 45% Modacrylic / 35% Lyocell / 20% Aramid

Protection: Arc Rating ATPV 10.1 calories / cm²

Colors: Navy (NV), Khaki (KH)*



To order, please call 1-877-GO ALTEC (1-877-462-5832), and specify the model number, waist size and length.

65

970287605 PMU2NV-42/32
970289097 PMU2NV-40/32



PERSONAL EQUIPMENT

USA: 1-877-GO ALTEC
(1-877-462-5832)

www.alteconnect.com

BULWARK COMFORT SERIES

The World's Largest Manufacturer and Industry Leader of Flame-Resistant Apparel



No Compromise

Bulwark Brand Labels on all FR clothing guarantees flame resistant for the life of the garment!

BROWN DUCK LINEMAN'S JACKET

JLC4 - Men's (Reg) S-3XL. (Long) L-2XL.
 Concealed, snap-front, storm flap closure.
 Lanyard access opening on center back, accommodates safety harness.
 Accommodates snap-on hood HLH2BD and vest jacket liner LLS2BD, sold separately.
 Shell: 11.0 oz. (390 g / m2) Duck, 88% Cotton / 12% Nylon, Water-repellent
 Fabric: Flame-resistant
 Lining: Flame-resistant, 6.5 oz. (220 g / m2)
 70% Nomex® / 30% Lenzing FR®
 Protection: Arc Rating ATPV 46.3 calories / cm2
 Colors: Brown Duck (BD)

	JLC4BD
Small	9705-67399
Medium	9705-67400
Large	9705-67401
X-Large	9702-87609
2X-Large	9705-67402
3X-Large	9705-67403
Large - Long	9705-67404
X-Large - Long	9705-67405
2X-Large - Long	9705-67406



BROWN DUCK HOODED JACKET

JLH4 - Men's (Reg) S-4XL. (Long) L-2XL.
 Permanently attached hood with adjustable drawcord. Lanyard access opening on center back, accommodates safety harness.
 Two front pouch-style pockets with reinforced bartacks.
 Fabric: Flame-resistant
 Shell: 11.0 oz (390 g / m2) Duck, 88% Cotton / 12% Nylon, Water-repellent
 Lining: Flame-resistant, 7 oz. (235 g / m2) 100% Cotton Sanded
 Protection: Arc Rating ATPV 35.0 calories / cm2
 Colors: Brown Duck (BD)

P/N 9703-46159	JLH4BD-S-REG	P/N 9703-46156	JLH4BD-3XL-REG
P/N 9703-46158	JLH4BD-M-REG	P/N 9703-46157	JLH4BD-4XL-REG
P/N 9703-41992	JLH4BD-L-REG	P/N 9703-46153	JLH4BD-L-LONG
P/N 9703-46160	JLH4BD-XL-REG	P/N 9703-46154	JLH4BD-XL-LONG
P/N 9703-46161	JLH4BD-2XL-REG	P/N 9703-46155	JLH4BD-2XL-LONG

BROWN DUCK DUNGAREE

PLJ8 - Men's 28-50 Even.
 Five jean-style pockets. Triple-needle felled outseam.
 Rule pocket and utility pocket on right leg.
 Hammer loop and utility pocket on left leg.

Fabric: Flame-resistant, 11.0 oz. (390 g / m2) 88% Cotton / 12% Nylon, Water-repellent
 Protection: Arc Rating ATPV 14.6 calories / cm2
 Colors: Brown Duck (BD), Navy Duck (NV), Olive Duck (OL)

970346049	PLJ8BD-28/30	970264152	PLJ8BD-36/30	970346056	PLJ8BD-44/30
970346083	PLJ8BD-28/32	970346087	PLJ8BD-36/32	970346090	PLJ8BD-44/32
970346117	PLJ8BD-28/34	970346121	PLJ8BD-36/34	970346125	PLJ8BD-44/34
970346050	PLJ8BD-30/30	970346053	PLJ8BD-38/30	970346057	PLJ8BD-46/30
970346084	PLJ8BD-30/32	970259007	PLJ8BD-38/32	970346091	PLJ8BD-46/32
970346118	PLJ8BD-30/34	970346122	PLJ8BD-38/34	970346126	PLJ8BD-46/34
970346051	PLJ8BD-32/30	970346054	PLJ8BD-40/30	970346058	PLJ8BD-48/30
970346085	PLJ8BD-32/32	970346088	PLJ8BD-40/32	970346092	PLJ8BD-48/32
970346119	PLJ8BD-32/34	970346123	PLJ8BD-40/34	970346127	PLJ8BD-48/34
970346052	PLJ8BD-34/30	970346055	PLJ8BD-42/30	970346059	PLJ8BD-50/30
970346086	PLJ8BD-34/32	970346089	PLJ8BD-42/32	970346093	PLJ8BD-50/32
970346120	PLJ8BD-34/34	970346124	PLJ8BD-42/34	970346128	PLJ8BD-50/34

PLJ8-BD Brown Duck
 PLJ8-NV Navy Duck is also available
 PLJ8-OL Olive Duck is also available

*To order Navy Duck or Olive Duck colors, please call 1-877-GO ALTEC (1-877-462-5832), and specify the model number, waist size and length.



PERSONAL EQUIPMENT

USA: 1-877-GO ALTEC
 (1-877-462-5832)

www.alteconnect.com



BROWN DUCK BIB OVERALLS

- Fabric: EXCEL FR® ComforTouch®
- Blend: Outershell- 11.5 oz. Duck 88% cotton/ 12% nylon water repellent
- 11.5oz Heavy duty Brown Duck DWR outlasts the competition. Theirs washes off after only 3HW, while Bulwark ComforTouch DWR finish continues to perform up to 15HW
- Protection: Overall - ATPV 14.6 calories/cm² (HRC 2)
- Features: Nomex® taped brass zipper fly front, covered, Covered elastic straps, Non-conductive heavy-duty release buckle.
- One large front bib pocket with pencil stall. Two set-in pockets, watch pocket, two large hip pockets, hammer loop, tool pocket, and double tool pocket. Side vent openings with snap closures
- Reinforced double knees
- Sewn with FR thread conforming to the requirements of ASTM F 1506
- Style improvements: removed elastic from the back, added covered elastic to the shoulder straps, replaced button sides with concealed snaps
- Superior construction details vs. all the competition
- Colors: Brown Duck (BD), Navy Duck (ND)



No Compromise



Small
Medium
Large
X-Large
2X-Large
3X-Large

BROWN DUCK	NAVY DUCK
BLF8-BD	BLF8-ND
9703-46039	9705-67407
9703-46040	9703-46046
9702-64138	9703-46045
9702-58994	9703-46047
9702-89089	9703-46048
9703-46038	9703-46044

Large - Long
X-Large - Long
2X-Large - Long

BROWN DUCK	NAVY DUCK
BLF8-BD	BLF8-ND
9703-46035	9703-46041
9703-46036	9703-46042
9703-46037	9703-46043

BIB OVERALLS

BLC8 - Men's (Reg) S-3XL. (Long) L-2XL
Fabric: Flame-resistant
Shell: 7 oz. (235 g / m²) 88% Cotton / 12% Nylon
Water-repellent
Insulation Package: 12 oz. (405 g / m²)
Lining: 100% Cotton
Insulation: 100% Modacrylic
Protection: Arc Rating ATPV 43.3 calories / cm²
Colors: Navy (NV), Royal Blue (RB)

Small
Medium
Large
X-Large
2X-Large
3X-Large
Large - Long
X-Large - Long
2X-Large - Long

NAVY	ROYAL BLUE
BLC8-NV	BLC8-RB
9705-67408	9705-67417
9705-67409	9705-67418
9705-67410	9705-67419
9705-67411	9705-67420
9705-67412	9705-67421
9705-67413	9705-67422
9705-67414	9705-67423
9705-67415	9705-67424
9705-67416	9705-67425

BIB OVERALLS

BLN4 - Men's (Reg) S-3XL. (Long) L-2XL.
Fabric: Flame-resistant, 11.0 oz. (390 g / m²) Duck, 88% Cotton / 12% Nylon, Water-repellent
Insulation Package: 12 oz. (405 g / m²)
Lining: 100% Cotton
Insulation: 100% Modacrylic
Protection: Arc Rating ATPV 56.6 calories / cm²
Color: Brown Duck (BD)

Small
Medium
Large
X-Large
2X-Large
3X-Large
Large - Long
X-Large - Long
2X-Large - Long

BROWN DUCK
BLN4-BD
9705-67426
9705-67427
9705-67428
9705-67429
9705-67430
9705-67431
9705-67432
9705-67433
9705-67434



HI-VISIBILITY FLAME-RESISTANT LONG SLEEVE T-SHIRT

SMK2 - Men's (Reg) S-5XL.
Self fabric crewneck-style collar and hemmed sleeves.
Tagless brand label and warning label.
Full side seam gusset.
Fabric: Flame-resistant, 8.75 oz. (300 g / m²) 70% Modacrylic / 15% FR Lenzing® / 15% Rayon
Protection: Arc Rating ATPV 8.1 calories / cm²
Flame-resistant ANSI 107-2010 Class 3 Level 2 Compliant
Color: Yellow / Green (HV)

SMK2HV			
Small	9703-46186	2X-Large	9703-46190
Medium	9703-46187	3X-Large	9703-46191
Large	9703-46188	4X-Large	9703-46192
X-Large	9703-46189	5X-Large	9705-68106



PERSONAL EQUIPMENT

USA: 1-877-GO ALTEC
(1-877-462-5832)

www.alteconnect.com



BULWARK COMFORT SERIES

The World's Largest Manufacturer and Industry Leader of Flame-Resistant Apparel

Bulwark Brand Labels on all FR clothing guarantees flame resistant for the life of the garment!

PERSONAL EQUIPMENT

No Compromise

ZIP-FRONT HOODED FLEECE SWEATSHIRT



SEH4 - Men's (Reg) S-5XL. (Long) M-5XL.
 Hood with drawstring closure. Zipper front. Rib knit.
 Fabric: Flame-resistant, 12.5 oz. 95% Cotton/5% Spandex
 Protection: Arc Rating EBT 17.0 calories / cm2
 Colors: Navy (NV), Orange (OR), Charcoal (CH)

	NAVY SEH4-NV	CHARCOAL SEH4-CH		NAVY SEH4-NV	CHARCOAL SEH4-CH
Small	9705-67435	9705-67449	Medium-Long	9705-67358	9705-67359
Medium	9705-67436	9705-67450	Large - Long	9705-67443	9705-67457
Large	9705-67437	9705-67451	X-Large - Long	9705-67444	9705-67458
X-Large	9705-67438	9705-67452	2X-Large - Long	9705-67445	9705-67459
2X-Large	9705-67439	9705-67453	3X-Large - Long	9705-67446	9705-67460
3X-Large	9705-67440	9705-67454	4X-Large - Long	9705-67447	9705-67461
4X-Large	9705-67441	9705-67455	5X-Large - Long	9705-67448	9705-67462
5X-Large	9705-67442	9705-67456			

ZIP-FRONT HOODED FLEECE SWEATSHIRT

SEH2NV - Men's (Reg) S-3XL. (Long) M-3XL.
 Two-ply hood with drawstring closure and ¼ zip-front. Rib knit cuff and waistband. Side seam pockets. Raglan sleeve.
 Fabric: Flame-resistant, 13 oz. (440 g / m2)
 100% Cotton brushed fleece
 Protection: Arc Rating ATPV 18.0 calories/cm2
 Color: Navy (NV)



	NAVY SEH2NV		NAVY SEH2NV
Small	9705-67463	Medium-Long	9705-67486
Medium	9705-67464	Large - Long	9705-67469
Large	9705-67465	X-Large - Long	9705-67470
X-Large	9705-67466	2X-Large - Long	9705-67471
2X-Large	9705-67467	3X-Large - Long	9705-67472
3X-Large	9705-67468		

PULL-OVER HOODED FLEECE SWEATSHIRT

SMH2 - Men's (Reg) S-3XL. (Long) M-3XL.
 Two-ply hood with drawstring closure
 Rib knit cuff and waistband
 Kangaroo pouch pocket
 Fabric: Flame-resistant, 8.7 oz. (375 g / m2)
 62% Modacrylic, 38% Aramid, Brushed Fleece
 Protection: Arc Rating EBT 17.0 calories / cm2
 Color: Navy (NV)



	NAVY SMH2NV
Small	9705-67473
Medium	9705-67474
Large	9705-67475
X-Large	9705-67476
2X-Large	9705-67477
3X-Large	9705-67478
Medium - Long	9705-67933
Large - Long	9705-67479
X-Large - Long	9705-67480
2X-Large - Long	9705-67481
3X-Large - Long	9705-67482

USA: 1-877-GO ALTEC
(1-877-462-5832)

www.alteconnect.com





No Compromise

PERSONAL EQUIPMENT

**USA: 1-877-GO ALTEC
(1-877-462-5832)**

www.alteconnect.com

1/4 ZIP-FRONT MODACRYLIC FLEECE SWEATSHIRT

SMZ6 - Men's (Reg) S-4XL.
Raglan sleeve. Inset chest pocket with zipper closure
Side seam pockets with zipper closure
Hemmed sleeve and bottom opening
Adjustable waist toggles concealed inside waistband.
Brushed fleece on both sides.
Fabric: Flame-resistant, 12 oz. (405 g / m2)
70% Modacrylic / 30% Rayon, Double Brushed Fleece
Protection: Arc Rating EBT 11.5 calories / cm²
Color: Navy (NV)

P/N 9705-67483 SMZ6-NV-S
P/N 9705-67484 SMZ6-NV-M
P/N 9705-67485 SMZ6-NV-L
P/N 9705-28997 SMZ6-NV-XL
P/N 9705-67487 SMZ6-NV-2XL
P/N 9705-67488 SMZ6-NV-3XL
P/N 9705-67489 SMZ6-NV-4XL



ZIP-FRONT HOODED FLEECE SWEATSHIRT

SMH6 - Men's (Reg) S-3XL. (Long) M-3XL.
Single-ply hood with drawstring closure. Zipper front.
Hemmed sleeves with elastic waist. Two patch pockets.
Brushed fleece on both sides.
Fabric: Flame-resistant, 8 oz. (270 g / m2) 65% Modacrylic /
23% Nomex® IIIA / 10% Kevlar® Aramid / 2% Carbon, Double
Brushed Fleece
Protection: Arc Rating EBT 17.0 calories / cm²
Color: Navy (NV)

P/N 9705-67490 SMH6-NV-S
P/N 9705-67491 SMH6-NV-M
P/N 9705-67492 SMH6-NV-L
P/N 9705-67493 SMH6-NV-XL
P/N 9705-67494 SMH6-NV-2XL
P/N 9705-67495 SMH6-NV-3XL
P/N 9705-67936 SMH6-NV-M-LONG
P/N 9705-67496 SMH6-NV-L-LONG
P/N 9705-67497 SMH6-NV-XL-LONG
P/N 9705-67498 SMH6-NV-2XL-LONG
P/N 9705-67599 SMH6-NV-3XL-LONG



FR3 JACKET

JLF6 - Men's (Reg) S-4XL. (Long) L-4XL.
Separating, Nomex® taped, non-conductive zipper.
Stand-up, lined collar
Concealed snap closure on cuff.
Napoleon chest pocket with concealed zipper closure.
Two large external kangaroo-style pockets.
Raglan sleeve.
Concealed drawstring waistband. Accommodates snap-on hood HLH6BN
and liners LNL2, LML6, LNS2 and LMS6, sold separately.
Fabric: Flame-resistant
Shell: 6 oz. (205 g / m2) 88% Cotton / 12% Nylon
Water-resistant, Wind-resistant, Breathable
Lining: Flame-resistant, 7 oz. (235 g / m2) 70% Modacrylic/30% Rayon Fleece
Protection: Arc Rating Ebt 26.3 calories / cm²
Colors: Black (BK), Navy (NV)

	BLACK	NAVY
	JLF6-BK	JLF6-NV
Small	9705-67500	9705-67512
Medium	9705-67501	9705-67513
Large	9705-67502	9705-67514
X-Large	9705-67503	9705-67515
2X-Large	9705-67504	9705-67516
3X-Large	9705-67505	9705-67517
4X-Large	9705-67506	9705-67518

	BLACK	NAVY
	JLF6-BK	JLF6-NV
Large - Long	9705-67507	9705-67519
X-Large - Long	9705-67508	9705-67520
2X-Large - Long	9705-67509	9705-67521
3X-Large - Long	9705-67510	9705-67522
4X-Large - Long	9705-67511	9705-67523

BULWARK COMFORT SERIES

The World's Largest Manufacturer and Industry Leader of Flame-Resistant Apparel



No Compromise

Bulwark Brand Labels on all FR clothing guarantees flame resistant for the life of the garment!

PERSONAL EQUIPMENT

USA: 1-877-GO ALTEC
(1-877-462-5832)

www.alteconnect.com



ZIP-IN / ZIP-OUT JACKETS & LINERS

Separating, heavy-duty, Nomex® taped, brass zipper.
Two-piece, lined collar. Two-piece, adjustable cuff.
Banded waist with button-close tabs.
Two large inset, welted-slash pockets.
Left sleeve pocket
Accommodates LML2 zip-in sleeved liner, sold separately.
Fabric: Flame-resistant, 9 oz. (305 g / m²) Twill, 100% Cotton
Protection: Arc Rating ATPV 10.6 calories / cm²
When worn with LML2 ensemble, Arc Rating is ATPV 61.3 calories / cm²

NAVY JEW2-NV

Small	9705-67524	3X-Large	9705-67529
Medium	9705-67525	Large - Long	9705-67530
Large	9705-67526	X-Large - Long	9705-67531
X-Large	9705-67527	2X-Large - Long	9705-67532
2X-Large	9705-67528		

Availability:

JEW2 - Men's (Reg) S-3XL. (Long) L-2XL.
Color: Navy (NV).



PARKAS

Accommodates snap-on hoods HLH2NV and HLH2RB, sold separately
Fabric: Flame-resistant
Shell: 7 oz. (235 g / m²) Twill, 88% Cotton / 12% Nylon, Water-repellent
Insulation package: 12 oz. (405 g / m²)
Lining: 100% Cotton
Insulation: 100% Modacrylic
Protection: Arc Rating ATPV 43.3 calories / cm²

NAVY JLP8-NV

Small	9705-67533	Large - Long	9705-67539
Medium	9705-67534	X-Large - Long	9705-67540
Large	9705-67535	2X-Large - Long	9705-67541
X-Large	9705-67536	Availability:	
2X-Large	9705-67537	JLP8 - Men's (Reg) S-3XL. (Long) L-2XL.	
3X-Large	9705-67538	Colors: Navy (NV), Royal Blue (RB)	

BALACLAVA WITH FACE MASK

Sized to fit comfortably over head
Articulated face mask for varying degrees of coverage
Double-layer in face area
Extra long neck skirt
Soft and comfortable.
Fit to wear under hard hat and in all HRC2 environments.
Fabric: Flame-resistant, 8.75 oz. (300 g / m²) 70% Modacrylic / 15% FR Lenzing® / 15% Rayon Knit
Protection: Arc Rating ATPV 8.1 calories/cm²
Color: Navy (NV)

P/N 9705-67542 HMB2NV

KNIT BALACLAVA

Double-layer in face area.
Extra long neck skirt.
Soft and comfortable.
Fabric: Flame-resistant, 8.4 oz. (284 g / m²) Nomex® Knit
Protection: Arc Rating ATPV 26.0 calories / cm²
Color: Natural (NA)

P/N 9705-67544 HNB2NA



FLEECE BEANIE

Two-ply
Double-brushed fleece for comfort and warmth
Fit to wear under hard hat
Fabric: Flame-resistant, 12 oz. (405 g / m²)
70% Modacrylic / 30% Rayon
Protection: Arc Rating EBT 11.5 calories/cm²
Color: Navy (NV)

P/N 9705-67543 HMC4NV





iQ WOMEN'S POLO

Single button front placket, self-fabric collar, set-in sleeves
 Darts for a feminine fit, concealed rib knit cuffs
 Shirring at back with 2 ply yoke
 iQ SERIESTM seam tag and iQ SERIESTM reseller hang tag.
 Full side seam gusset.
 Fabric: Flame-resistant
 5.3 oz. (180 g / m2) 69% Cotton/25% Polyester/6% Polyoxadiazole
 Protection: Arc Rating ATPV 8.2 calories / cm2



No Compromise

	BLUE	CHARCOAL
	QT11-DB	QT11-CH
X-Small	9705-67587	9705-67593
Small	9705-67588	9705-67594
Medium	9705-67589	9705-67595
Large	9705-67590	9705-67596
X-Large	9705-67591	9705-67597
2X-Large	9705-67592	9705-67598

Availability:
 QT11 - Women's (Reg) XS-2XL
 Colors: Black (BK), Blue (BL),
 Charcoal (CH), Dark Blue (DB),
 Red (RD), Tan (TN)

WOMEN'S STRAIGHT FIT SANDED DENIM JEAN

This straight fit sits just below the natural waist and has a straight thigh and leg opening that will fit over work boots.
 One-piece waistband with metal button closure (metal is not exposed to the skin). New, soft pre-wash and sanded fabric for modern and comfortable look.

Fabric: Flame-resistant, 12.5 oz. (425 g / m2)
 100% Pre-washed Cotton Denim
 Protection: Arc Rating ATPV 18.0 calories / cm2

9705-67545	PEJWSD-4	9705-67558	PEJWSD-17
9705-67546	PEJWSD-5	9705-67559	PEJWSD-18
9705-67547	PEJWSD-6	9705-67560	PEJWSD-19
9705-67548	PEJWSD-7	9705-67561	PEJWSD-20
9705-67549	PEJWSD-8	9705-67562	PEJWSD-21
9705-67550	PEJWSD-9	9705-67563	PEJWSD-22
9705-67551	PEJWSD-10	9705-67564	PEJWSD-23
9705-67552	PEJWSD-11	9705-67565	PEJWSD-24
9705-67553	PEJWSD-12	Availability:	
9705-67554	PEJWSD-13	PEJW - Women's 4-24.	
9705-67555	PEJWSD-14	Color: Sanded Denim (SD)	
9705-67556	PEJWSD-15		
9705-67557	PEJWSD-16		

WOMEN'S CURVY FIT DENIM BLEND JEAN

This new curvy fit sits a little below the natural waist. It has a defined waist with room in the hips and seat that allow for curves. One-piece waistband with metal button closure (metal is not exposed to the skin). Five jean style pockets. Denim blend fabric for durability and comfort. Curvy fit sits a little below the natural waist. It has a defined waist with room in the hips and seat that allow for curves.

Fabric: Flame-resistant, 12.5 oz. (425 g / m2) 70% Cotton /30% Modacrylic
 Protection: Arc Rating EBT 13.0 calories/cm2

9705-67566	PMJ5DD-4	9705-67579	PMJ5DD-17
9705-67567	PMJ5DD-5	9705-67580	PMJ5DD-18
9705-67568	PMJ5DD-6	9705-67581	PMJ5DD-19
9705-67569	PMJ5DD-7	9705-67582	PMJ5DD-20
9705-67570	PMJ5DD-8	9705-67583	PMJ5DD-21
9705-67571	PMJ5DD-9	9705-67584	PMJ5DD-22
9705-67572	PMJ5DD-10	9705-67585	PMJ5DD-23
9705-67573	PMJ5DD-11	9705-67586	PMJ5DD-24
9705-67574	PMJ5DD-12	Availability:	
9705-67575	PMJ5DD-13	PMJ5 - Women's 4-24.	
9705-67576	PMJ5DD-14	Color: Dark Denim (DD)	
9705-67577	PMJ5DD-15		
9705-67578	PMJ5DD-16		



PEJWSD

PMJ5DD

PERSONAL EQUIPMENT

USA: 1-877-GO ALTEC
 (1-877-462-5832)

www.alteconnect.com





BASHLIN

JOURNEYMAN LINEMAN'S WEAR

premium comfort • quality materials • exclusively designed fit

For over 80 years, Bashlin products have been recognized by linemen for their quality and comfort. Altec is proud to continue this tradition with the introduction of "Bashlin's Journeyman Lineman's Wear". These pants and shirts meet the NFPA 70E, NESC, ASTM, and OSHA requirements for FR Cotton Clothing worn by utility workers. But more than just meeting the requirements, the Bashlin Journeyman line offers an unmatched level of comfort and utility for the lineman; *the features Bashlin offers are simply not available in products designed for the general industry.*

The Bashlin Difference:

- **JEANS FABRIC** - 100% cotton, FR denim made by Mount Vernon, one of the *premier mills* in the USA
- **RELAXED / REGULAR FIT OPTIONS** - offering the regular fit for a more traditional lineman or a relaxed fit to meet the preferences of the younger and more fashion-conscious lineman

- **PREMIUM QUALITY** - Double-needle reinforced stitching for strength, Bar tacks on all possible stress points (pockets and zip front) for strength, Reinforced side seam for strength and durability, Felled inseam for strength

- **FEATURES** - Reinforced Ruler pocket for the small tools the lineman uses, 17" ankle openings to fit over boots, 4 button cuff for strength, shirt with a longer tail and unfinished bottom to reduce the bulk of the shirt, oversized and reinforced belt loops

- **COMFORT** - Fuller Hip and Thigh for comfort - *The "Climber's Gusset" is a key feature on the pant, giving additional freedom of movement for working on poles, towers, or bucket trucks; the gusset is made so that the pant has extra room to climb the poles or get on and off equipment - greatly minimizing risk of tears in the inseams*
- **FLAME-RESISTANCE** - Guaranteed to last the life of the product as long as nothing bleach-related goes into the product
- **STONE-WASH / REGULAR WASH OPTIONS** - offering the regular wash for a more traditional lineman or a lighter wash to meet the preferences of the younger and more fashion-conscious lineman
- **COMPLETELY CUSTOMIZABLE** - If your fleet has special requirements or preferences, Bashlin is able to make workwear based on customized options; some options include Non-FR fabric for mechanics or a mountain khaki fabric for operations managers and office personnel



The "Climber's Gusset" is a key feature on the pant, giving additional freedom of movement for working on poles, towers, or bucket trucks; the gusset is made so that the pant has extra room to climb the poles or get on and off equipment - greatly minimizing risk of tears in the inseams

Designed For Work As Well As Wear. Tested And Heartily Approved By Those That Climb For A Living.

A Fine "Fit" for the Professional Lineman

(Offered Exclusively through Altec Supply)



BASHLIN

professional FR workwear

*Bashlin's Journeyman Lineman's Wear
...a Fine "Fit" for the Professional Lineman*

PERSONAL EQUIPMENT

USA: 1-877-GO ALTEC
(1-877-462-5832)

www.alteconnect.com

premium comfort • quality materials • exclusively designed fit

BASHLIN DENIM - 14 oz. / 20 Cal*

STANDARD WEIGHT FR DENIM JEANS - REGULAR WASH

Regular Fit

Waist	32" Inseam	34" Inseam	36" Inseam
28"	9703-14477	9703-31366	9703-31464
30"	9703-14478	9703-31367	9703-31465
32"	9703-14479	9703-31368	9703-31466
34"	9703-14480	9703-31369	9703-31467
36"	9703-14481	9703-31370	9703-31468
38"	9703-14482	9703-31371	9703-31469
40"	9703-14483	9703-31372	9703-31470
42"	9703-14484	9703-31373	9703-31471
44"	9703-14485	9703-31374	9703-31472
46"	9703-14486	9703-31375	9703-31473
48"	9703-14487	9703-31376	9703-31474

Relaxed Fit

Waist	32" Inseam	34" Inseam	36" Inseam
28"	9703-14488	9703-31377	9703-31475
30"	9703-14489	9703-31378	9703-31477
32"	9703-14490	9703-31379	9703-31478
34"	9703-14491	9703-31381	9703-31479
36"	9703-14492	9703-31383	9703-31480
38"	9703-14493	9703-31384	9703-31481
40"	9703-14494	9703-31387	9703-31482
42"	9703-14495	9703-31388	9703-31483
44"	9703-14496	9703-31390	9703-31484
46"	9703-14497	9703-31393	9703-31485
48"	9703-14498	9703-31394	9703-31486

STANDARD WEIGHT FR DENIM JEANS - STONE WASH

Regular Fit

Waist	32" Inseam	34" Inseam	36" Inseam
28"	9703-29409	9703-31437	9703-31487
30"	9703-29418	9703-31438	9703-31488
32"	9703-29419	9703-31439	9703-31489
34"	9703-29420	9703-31440	9703-31490
36"	9703-29421	9703-31441	9703-31492
38"	9703-29423	9703-31442	9703-31493
40"	9703-29425	9703-31443	9703-31494
42"	9703-29426	9703-31444	9703-31495
44"	9703-29427	9703-31445	9703-31496
46"	9703-29428	9703-31447	9703-31497
48"	9703-29429	9703-31450	9703-31498

Relaxed Fit

Waist	32" Inseam	34" Inseam	36" Inseam
28"	9703-29430	9703-31452	9703-31499
30"	9703-29431	9703-31453	9703-31500
32"	9703-29432	9703-31454	9703-31501
34"	9703-29433	9703-31456	9703-31502
36"	9703-29434	9703-31457	9703-31503
38"	9703-29436	9703-31458	9703-31504
40"	9703-29437	9703-31459	9703-31506
42"	9703-29438	9703-31460	9703-31507
44"	9703-29440	9703-31461	9703-31508
46"	9703-29442	9703-31462	9703-31509
48"	9703-29444	9703-31463	9703-31510

14.75 oz. STANDARD WEIGHT DENIM JEANS

WEIGHT	14.75 oz./sy
CONTENT	100% Cotton
TYPE	3/1 RHT*
SHRINKAGE	3%/10 Washes
ATPV Rating (cal/cm2)	20.7
CHAR LENGTH (Avg 100 IL)	1.8"
ASTM 1506	YES
U/L 2112 APPROVAL	YES

* Right Hand Twill

Please call 1-877-GO ALTEC (1-877-462-5832) or contact your Altec Supply Account Manager for additional information on Bashlin's professional FR workwear.

(Offered Exclusively through Altec Supply)



BASHLIN

JOURNEYMAN LINEMAN'S WEAR

premium comfort • quality materials • exclusively designed fit



The Bashlin Difference:

- SAME PREMIUM QUALITY FEATURES AS THE 14.75 OZ. STANDARD DENIM JEAN - BUT LIGHTER IN WEIGHT (WITH AN 18 CAL RATING)!

12.75 oz. LIGHTWEIGHT STANDARD DENIM JEANS

WEIGHT	12.75 oz./sy
CONTENT	100% Cotton
TYPE	3/1 RHT*
SHRINKAGE	3%/10 Washes
ATPV Rating (cal/cm2)	18
CHAR LENGTH (Avg 100 IL)	1.8"
ASTM 1506	YES
U/L 2112 APPROVAL	YES

* Right Hand Twill

BASHLIN DENIM - 12.75 oz. / 18 Cal

LIGHTWEIGHT STANDARD FR DENIM JEANS - REGULAR WASH

Regular Fit

Waist	32" Inseam	34" Inseam	36" Inseam
28"	9703-66079	9703-66090	9703-66101
30"	9703-66080	9703-66091	9703-66102
32"	9703-66081	9703-66092	9703-66103
34"	9703-66082	9703-66093	9703-66104
36"	9703-66083	9703-66094	9703-66105
38"	9703-66084	9703-66095	9703-66106
40"	9703-66085	9703-66096	9703-66107
42"	9703-66086	9703-66097	9703-66108
44"	9703-66087	9703-66098	9703-66109
46"	9703-66088	9703-66099	9703-66110
48"	9703-66089	9703-66100	9703-66111

Relaxed Fit

Waist	32" Inseam	34" Inseam	36" Inseam
28"	9703-66112	9703-66122	9703-66132
30"	9703-66113	9703-66123	9703-66133
32"	9703-66114	9703-66124	9703-66134
34"	9703-64948	9703-62037	9703-66135
36"	9703-66115	9703-66125	9703-66136
38"	9703-66116	9703-66126	9703-66137
40"	9703-66117	9703-66127	9703-66138
42"	9703-66118	9703-66128	9703-66139
44"	9703-66119	9703-66129	9703-66140
46"	9703-66120	9703-66130	9703-66141
48"	9703-66121	9703-66131	9703-66142

LIGHTWEIGHT STANDARD FR DENIM JEANS - STONE WASH

Regular Fit

Waist	32" Inseam	34" Inseam	36" Inseam
28"	9703-66143	9703-66154	9703-66165
30"	9703-66144	9703-66155	9703-66166
32"	9703-66145	9703-66156	9703-66167
34"	9703-66146	9703-66157	9703-66168
36"	9703-66147	9703-66158	9703-66169
38"	9703-66148	9703-66159	9703-66170
40"	9703-66149	9703-66160	9703-66171
42"	9703-66150	9703-66161	9703-66172
44"	9703-66151	9703-66162	9703-66173
46"	9703-66152	9703-66163	9703-66175

Relaxed Fit

Waist	32" Inseam	34" Inseam	36" Inseam
28"	9703-66176	9703-66187	9703-66198
30"	9703-66177	9703-66188	9703-66199
32"	9703-66178	9703-66189	9703-66200
34"	9703-66179	9703-66190	9703-66201
36"	9703-66180	9703-66191	9703-66202
38"	9703-66181	9703-66192	9703-66203
40"	9703-66182	9703-66193	9703-66204
42"	9703-66183	9703-66194	9703-66205
44"	9703-66184	9703-66195	9703-66206
46"	9703-66185	9703-66196	9703-66207
48"	9703-66186	9703-66197	9703-66208

USA: 1-877-GO ALTEC
(1-877-462-5832)

www.alteconnect.com



A Fine "Fit" for the Professional Lineman
(Offered Exclusively through Altec Supply)



BASHLIN professional FR workwear

*Bashlin's Journeyman Lineman's Wear
...a Fine "Fit" for the Professional Lineman*

premium comfort • quality materials • exclusively designed fit

BASHLIN LONG SLEEVE T-SHIRT and LONG-SLEEVE HENLEY

The Bashlin Difference

HENLEY

- The classic 100% cotton 7.5oz jersey pocketed henley brings style and comfort to the workplace
- The 3 button placket provides comfort and the long sleeves give the FR protection needed on any job.

LONG SLEEVE "T"

- The basic long sleeve 100% cotton 7.5oz jersey "T" provides year round comfort for the hot or cool areas of the country with the FR protection



LONG SLEEVE SHIRTS

	HENLEY & T-SHIRT
WEIGHT	7.5 oz./sy
CONTENT	100% Cotton
TYPE	Jersey Knit
SHRINKAGE	up to 5%/3 Washes
ATPV Rating (cal/cm2)	8.9
CHAR LENGTH (Avg 100 IL)	3.1"
U/L 2112 APPROVAL	YES
* Right Hand Twill	

PREMIUM FR SHIRTS

LONG SLEEVE T-SHIRT

<u>Part Number</u>	<u>Size</u>
P/N 9703-66392	Small
P/N 9703-66393	Medium
P/N 9703-66394	Large
P/N 9703-66395	X-Large
P/N 9703-66396	XX-Large
P/N 9703-66397	3X-Large

LONG SLEEVE HENLEY

<u>Part Number</u>	<u>Size</u>
P/N 9703-66398	Small
P/N 9703-66399	Medium
P/N 9703-66400	Large
P/N 9703-66401	X-Large
P/N 9703-66402	XX-Large
P/N 9703-66403	3X-Large

Please call 1-877-GO ALTEC (1-877-462-5832) or contact your Altec Supply Account Manager for additional information on Bashlin's professional FR workwear.

PERSONAL EQUIPMENT

USA: 1-877-GO ALTEC
(1-877-462-5832)

www.alteconnect.com



BASHLIN

JOURNEYMAN LINEMAN'S WEAR

premium comfort • quality materials • exclusively designed fit

The Bashlin Difference

The "Made in USA" Bashlin FR workshirts were designed and created specifically for the working lineman. The shirts are made of 100% cotton and meet or exceed all the industry FR ratings.

Bashlin shirts feature several important characteristics that separate them from others in the industry: longer tails (so they won't pull out), unfinished bottoms (for the comfort of riding long distances), longer and fuller sleeves (allowing freedom to reach without binding), 2 breast pockets with flaps and a pencil slot, and a premium constructed 4-button cuff for strength and durability.

Bashlin button-down shirts are offered in the following fabrics and colors: washed denim, stonewashed denim and khaki twill.



Shown (Left to Right)
Khaki Twill
Washed Denim
Stone-Washed Denim

BUTTON-DOWN SHIRTS - KHAKI TWILL & DENIM

	SHIRTS	
	DENIM	KHAKI TWILL
WEIGHT	7.5 oz./sy	7.0 oz./sy
CONTENT	100% Cotton	100% Cotton
TYPE	2/1 RHT*	2/1 LHT*
SHRINKAGE	3%/10 Washes	3.5%/10 Washes
ATPV Rating (cal/cm2)	9.3	8.6
CHAR LENGTH (Avg 100 IL)	3.5"	3.5"
ASTM 1506	Yes	Yes
U/L 2112 APPROVAL	Yes	Yes

* Right Hand Twill

Please call 1-877-GO ALTEC (1-877-462-5832) or contact your Altec Supply Account Manager for additional information on Bashlin's professional FR workwear.

PREMIUM FR SHIRTS

Denim - Regular Wash

Part Number	Size
P/N 9703-14507	Small
P/N 9703-14508	Medium
P/N 9703-14509	Large
P/N 9703-14510	X-Large
P/N 9703-14511	XX-Large
P/N 9703-14512	3X-Large

Denim - Stone Wash

Part Number	Size
P/N 9703-31341	Small
P/N 9703-31342	Medium
P/N 9703-31343	Large
P/N 9703-31344	X-Large
P/N 9703-31345	XX-Large
P/N 9703-31346	3X-Large

Khaki Twill

Part Number	Size
P/N 9703-29657	Small
P/N 9703-29658	Medium
P/N 9703-29659	Large
P/N 9703-29660	X-Large
P/N 9703-29661	XX-Large
P/N 9703-29662	3X-Large



A Fine "Fit" for the Professional Lineman
(Offered Exclusively through Altec Supply)



CLASS 2 VEST

- Polyester Mesh
- 2" Silver Reflective Tape
- Zipper Closure
- 4 Interior Pockets
- Also available in Orange
- Sizes S/M, L/XL, 2X/3X, 4X/5X

Class 2 Vest - Lime
 P/N 9703-46380 V70632-S/M
 P/N 9703-46381 V70632-L/XL
 P/N 9703-46382 V70632-2X/3X
 P/N 9703-46383 V70632-4X/5X

JOB SIGHT™

High Visibility Apparel

CLASS 2 VEST - Adjustable

- ANSI/ISEA 107 Class 2 Compliant
- Polyester Mesh
- Two-Tone - 2" Silver Reflective Tape with Contrasting Backing
- Zipper Closure
- Mic Tabs
- 4 Interior Pockets
- Sizes M/XL - 2X/5X

P/N 9703-46372 V70839-M/XL - Orange
 P/N 9703-46373 V70839-2X/5X - Orange
 P/N 9703-46374 V70832-M/XL - Lime
 P/N 9703-46375 V70832-2X/5X - Lime



Class 3 Hooded High Visibility Sweatshirts

- ANSI/ISEA 107 Class 3 Compliant
- Hooded, Zipper closure, 2 pockets
- Polyester
- 2" Silver Reflective Tape
- Sizes S - 5X

Sweatshirt - Lime
 P/N 9703-46364 S78122-S
 P/N 9703-46365 S78122-M
 P/N 9703-46366 S78122-L
 P/N 9703-46367 S78122-XL
 P/N 9703-46368 S78122-2XL
 P/N 9703-46369 S78122-3XL
 P/N 9703-46370 S78122-4XL
 P/N 9703-46371 S78122-5XL



BOMBER II - HIGH VISIBILITY INSULATED JACKET

- Fluorescent yellow-green background material for excellent daytime visibility (For orange-red background material, please call 1-877-GO ALTEC (1-877-462-5832))
- A highly visible insulated winter wear jacket designed to provide warmth, comfort, and safety at an affordable price
- ANSI/ISEA 107 Class 3 compliant, 100% waterproof, jacket for high visibility
- Quilted polyester lining provides warmth and comfort
- 210 denier polyester shell for great wear
- 2" silver reflective tape reflects light for 360° nighttime conspicuity
- Ideal Applications: For use in environments where high visibility and warmth are desired for wearer safety and comfort

P/N 9705-88624 J26112-S
 P/N 9705-88625 J26112-M
 P/N 9705-88626 J26112-L
 P/N 9705-88627 J26112-XL
 P/N 9705-88628 J26112-2XL
 P/N 9705-88629 J26112-3XL
 P/N 9705-88630 J26112-4XL
 P/N 9705-88631 J26112-5XL

JOB SIGHT FRTM

Flame Resistant High Visibility Apparel *Revolutionary Comfort and Protection*



- 55% Modacrylic, 45% Cotton blend material, maximizes worker comfort, compliance, and safety
 - Meets ANSI 107 standard for high visibility and flame resistance
 - Meets ASTM F1506 for flame and arc resistant apparel
 - NFPA 70E compliant
 - HRC 1 Class 2 safety vests and HRC 2 Class 3 t-shirt and sweatshirt*
- * See facing page for more information for ordering Tingley's line of Flame Resistant High Visibility Apparel!

TINGLEY FLAME RESISTANT HI VISIBILITY APPAREL

A TRADITION SINCE 1896

Tingley's Job Sight FR™, high visibility, flame resistant apparel makes ANSI 107 and ASTM F1506 compliance easy. Advanced modacrylic/cotton blend material provides breathable stretch, durability and protection.



Class 3 FR High Visibility T-Shirt - LIME

- ANSI/ISEA 107 Class 3 Compliant T-Shirt
 - Meets ASTM F1506
 - Arc Rating 8.8 cal/cm²
 - Conforms to NFPA 70E - HRC 2
 - 8.5 Ounce, 55% Modacrylic/45% Cotton Blend – Solid
 - 2" FR Silver Reflective Tape
 - Long Sleeve
 - 1 Pocket
 - **Sizes S – 5X**
- | | |
|----------------|------------|
| P/N 9703-46400 | S85522-S |
| P/N 9703-46401 | S85522-M |
| P/N 9703-46402 | S85522-L |
| P/N 9703-46403 | S85522-XL |
| P/N 9703-46404 | S85522-2XL |
| P/N 9703-46405 | S85522-3XL |
| P/N 9703-46406 | S85522-4XL |
| P/N 9703-46407 | S85522-5XL |

Class 3 FR High Visibility Sweatshirt

- ANSI/ISEA 107 Class 3 Compliant Sweatshirt
- Meets ASTM F1506
- Arc Rating 16.0 cal/cm²
- Conforms to NFPA 70E - HRC 2
- 10.5 Ounce, 55% Modacrylic/45% Cotton Blend – Solid
- Concealed FR zipper closure
- 2" FR Silver Reflective Tape
- Hooded
- 2 Pockets
- **Sizes S – 5X**

Sweatshirt - Lime

- | | |
|----------------|------------|
| P/N 9705-88640 | S88122-S |
| P/N 9705-88641 | S88122-M |
| P/N 9705-88642 | S88122-L |
| P/N 9705-88643 | S88122-XL |
| P/N 9705-88644 | S88122-2XL |
| P/N 9705-88645 | S88122-3XL |
| P/N 9705-88646 | S88122-4XL |
| P/N 9705-88647 | S88122-5XL |



FR VEST - Class 2

- 6.5 Ounce, 55% Modacrylic/45% Cotton Blend – Solid
- ANSI/ISEA 107 Class 2 Compliant Vest
- D-Ring Access for Fall Protection Harness
- Meets ASTM F1506
- Arc Rating 6.8 cal/cm²
- Conforms to NFPA 70E - HRC 1
- 2" FR Silver Reflective Tape
- FR Hook & Loop Closure
- 2 Interior Pockets
- **Sizes S/M, L/XL, 2X/3X, 4X/5X**

- | | |
|----------------|---------------------|
| P/N 9705-88616 | V81622-S/M - Lime |
| P/N 9705-88617 | V81622-L/XL - Lime |
| P/N 9705-88618 | V81622-2X/3X - Lime |
| P/N 9705-88619 | V81622-4X/5X - Lime |

FR VEST - Solid, Hook & Loop

- ANSI/ISEA 107 Class 2 Compliant Vest
- Meets ASTM F1506
- Arc Rating 6.8 cal/cm²
- Conforms to NFPA 70E - HRC 1
- 6.5 Ounce, 55% Modacrylic/45% Cotton Blend – Solid
- 2" FR Silver Reflective Tape
- FR Hook & Loop Closure
- 2 FR Mic Tabs
- 5 Exterior Pockets
- 3 Interior Pockets
- **Sizes S/M, L/XL, 2X/3X, 4X/5X**

- | | |
|----------------|---------------------|
| P/N 9702-88620 | V81832-S/M - Lime |
| P/N 9702-88621 | V81832-L/XL - Lime |
| P/N 9702-88622 | V81832-2X/3X - Lime |
| P/N 9702-88623 | V81832-4X/5X - Lime |



PERSONAL EQUIPMENT

USA: 1-877-GO ALTEC
(1-877-462-5832)

www.alteconnect.com

Please contact your Altec Supply Account Manager for more information regarding Job Sight™ High Visibility Apparel.

TINGLEY

A TRADITION SINCE 1896

PERSONAL EQUIPMENT

USA: 1-877-GO ALTEC
(1-877-462-5832)

www.alteconnect.com

HIGH VISIBILITY RAINWEAR – COMFORT-BRITE

- ANSI/ISEA 107 Class 3 compliant suit, jacket, and coat for high visibility
- Loaded with special features for multipurpose applications
- 2" silver reflective tape reflects light for 360° nighttime conspicuity
- Fluorescent orange-red or yellow-green background material for excellent daytime visibility
- Full cut shoulder with 90° sleeve to body angle for maximum freedom of movement
- Therm-O-Rad sealed seams for 100% waterproof protection
- Zipper/storm fly front seals out wind, rain, and contaminants; mildew-resistant
- Non-conductive hardware
- Roll-a-way hood in collar design; full-vented cape back provides improved air circulation
- D-ring access for fall protection harness
- Suspenders with quick release buckles and crossover; easy access cargo pockets
- Hook & loop take-up straps on sleeve and ankle cuffs for adjustable fit
- Flame resistant tested ASTM D6413. Self extinguishing with flameout and afterglow less than 2 seconds after removal of ignition source. (Test method ASTM D6413)
- **Sizes Small – 5X**



FLOURESCENT YELLOW/GREEN

TINGLEY ITEM	SMALL	MEDIUM	LARGE	X-LARGE	2X-LARGE	3X-LARGE	4X-LARGE	5X-LARGE
J53122 JACKET	9703-46480	9703-46481	9703-46482	9703-46483	9703-46484	9703-46485	9703-46486	9703-46487
O53122 OVERALL	9703-46488	9703-46489	9703-46490	9703-46491	9703-46492	9703-46493	9703-46494	9703-46495
C53122 48" COAT	9703-46496	9703-46497	9703-46498	9703-46499	9703-46500	9703-46501	9703-46502	

FLOURESCENT ORANGE-RED

TINGLEY ITEM	SMALL	MEDIUM	LARGE	X-LARGE	2X-LARGE	3X-LARGE	4X-LARGE	5X-LARGE
J53129 JACKET	9703-46503	9703-46504	9703-46505	9703-46506	9703-46507	9703-46508	9703-46509	9703-46510
O53129 OVERALL	9703-46511	9703-46512	9703-46513	9703-46514	9703-46515	9703-46516	9703-46517	9703-46518

NEW! ~ Revolutionary Quad-Hazard™ Protection

- Offers High Visibility, Liquid Proof, Arc Flash And Flash Fire Protection
- Patent Pending Thermo-Grid™ technology helps block out heat energy while the flame resistant PVC coating on Nomex® provides 100% liquid proof protection in a soft, lightweight suit
- ANSI/ISEA 107 Class 3 compliant suit, jacket and coat for flame resistance and high visibility
- Conforms to ASTM F1891 for Arc Thermal Performance and NFPA 70E - HRC 2.
- Jacket and overall styles conform to ASTM F2733 for Flash Fire Performance
- Fluorescent background colors for excellent daytime visibility
- 2" silver reflective tape reflects light for 360° nighttime conspicuity
- Overhead shoulder design for complete freedom of movement while working overhead
- Therm-O-Rad sealed seams for 100% liquid proof protection
- Zipper/storm fly front with snap closure and hidden hardware seals out heat, wind, rain and contaminants; D-ring access for fall protection harness
- Flame resistant corduroy collar with roll-a-way hood for comfort and convenience
- Oversized 3 piece hood with adjustable hook & loop take-up strap for safe fit
- Chemical Resistance: Many acids, oils, alcohols, salts, and alkalies
- **Jackets and overalls - Small – 5X; 48" coat - Small - 4XL**

ECLIPSE™



FLOURESCENT YELLOW/GREEN

TINGLEY ITEM	SMALL	MEDIUM	LARGE	X-LARGE	2X-LARGE	3X-LARGE	4X-LARGE	5X-LARGE
J44122 JACKET	9706-40838	9706-40839	9706-40840	9706-40841	9706-40842	9706-40843	9706-40844	9706-40845
O44122 OVERALL	9706-40846	9706-40847	9706-40848	9706-40849	9706-40850	9706-40851	9706-40852	9706-40853
C44122 48" COAT	9706-40854	9706-40855	9706-40856	9706-40857	9706-40858	9706-40859	9706-40860	-

Flourescent Orange-Red Is Available Upon Request. Please call 1-877-GO ALTEC (1-877-462-5832)

STORAGE BAG

- Handy bag for storing and transporting your FR Equipment
- Measures 21" x 26"

9705-88701 B53102



Altec Supply

OUTERWEAR



HIGH VISIBILITY OUTERWEAR – VISION

- ANSI/ISEA 107 Class 3 compliant suit and jacket for high visibility and breathability
- Designed for use in multipurpose applications
- Fluorescent yellow-green background material for excellent daytime visibility
- 2" silver reflective tape reflects light for 360° nighttime conspicuity
- Waterproof, breathable fabric for all season comfort
- Full cut shoulder with 90° sleeve to body angle for maximum freedom of movement
- Stitched and taped sealed seams for 100% waterproof protection
- Storm fly front seals out wind and rain
- Roll-a-way adjustable hood in collar design for added convenience
- Easy access cargo pockets with hook & loop closure
- Suspenders with quick release buckles and crossover
- Elastic waist pants with adjustable drawcord
- Side openings on pants with flap closure
- Hook & loop take-up straps on sleeves and ankle cuffs for adjustable fit
- **Sizes Small – 5X**

FLOURESCENT YELLOW/GREEN

TINGLEY ITEM	SMALL	MEDIUM	LARGE	X-LARGE	2X-LARGE	3X-LARGE	4X-LARGE	5X-LARGE
J23122 JACKET	9703-46456	9703-46457	9703-46458	9703-46459	9703-46460	9703-46461	9703-46462	9703-46463
O23122 OVERALL	9703-46464	9703-46465	9703-46466	9703-46467	9703-46468	9703-46469	9703-46470	9703-46471
P23122 PANTS	9703-46472	9703-46473	9703-46474	9703-46475	9703-46476	9703-46477	9703-46478	9703-46479

DuraScrim™ Double Coated PVC On Polyester Suit

- Extremely high tear strength is the result of an open weave polyester scrim fabric being sandwiched between two layers of flame resistant PVC coating
- Therm-O-Rad sealed seam construction for good chemical splash protection
- Thicker outside coating for better abrasion resistance
- Lighter interior coating protects fabric from chemical contamination.
- Flame resistant. Self extinguishing with flameout and afterglow less than 2 seconds after removal of ignition source (Test method ASTM D6413)
- Batwing sleeve construction and generously cut for maximum freedom of movement
- Therm-O-Rad sealed seams for 100% waterproof protection
- Storm fly front seals out wind, rain, and contaminants
- Take-up snaps on sleeves and ankle cuffs for adjustable fit
- Self material collar resists contamination
- Non-conductive, non-corrosive hardware
- Mildew resistant
- Flame-resistant tested*
- Chemical Resistance: Many acids, oils, alcohols, salts and alkalies
- **Sizes Small – 5X**



TINGLEY ITEM	SMALL	MEDIUM	LARGE	X-LARGE	2X-LARGE	3X-LARGE	4X-LARGE	5X-LARGE
HOOD								
H56107 Hood Only	9705-88648							
JACKETS								
J56207 Hood Snaps	9705-88649	9705-88650	9705-88654	9705-88652	9705-88653	9705-88654	-	-
J56107 Attached Hood	9705-88655	9705-88656	9705-88657	9705-88658	9705-88659	9705-88660	-	-
OVERALLS								
O56007 Plain Front	9705-88661	9705-88662	9705-88663	9705-88664	9705-88665	9705-88666	-	-
O56107 Snap Fly Front	9705-88867	9705-88868	9705-88869	9705-88870	9705-88871	9705-88872	9705-88873	9705-88874
PANTS								
P56007 Plain Front	9705-88675	9705-88676	9705-88677	9705-88678	9705-88679	9705-88680	-	-
SUIT								
S56307 3 Piece Suit	9705-88681	9705-88682	9705-88683	9705-88684	9705-88685	9705-88686	9705-88687	9705-88688
COAT								
C56207 Coat	9705-88689	9705-88690	9705-88691	9705-88692	9705-88693	9705-88694	-	-

PERSONAL EQUIPMENT

USA: 1-877-GO ALTEC
(1-877-462-5832)

www.alteconnect.com



ArcLite™

by NASCO

ArcLite™ is the most popular foul weather product designed specifically for utility workers who may be exposed to electric arcs. With a feature packed design, ArcLite is sure to meet the needs of the demanding electric utility industry.

Features & Benefits

- Arc and Flame Resistance
 - Does Not Melt, Drip, Ignite, or Break Open
 - Minimizes Heat Transfer Burns
- Waterproof
- Lightweight
- Soft, Flexible
- Designed by Linemen
- Limited Chemical Splash Resistance

Recommended Applications

- Electric Utility
- Electrical Maintenance
- Meter Service
- Electrical Switching
- Telecommunication workers
- CATV workers

ArcLite™ 1000/1500 Items 8 oz/yd² FR Synthetic Leather PU/PVC

Following items come standard with: two pockets with Velcro® closure, non-conductive zipper front with dual over flaps and snaps, Nomex® mesh ventilation system, fall protection access, Velcro® tab type wrist adjusters.

- **1503J** Waist length jacket, 3 piece hood-in-collar, 3M 2" reflective trim around chest, over-shoulder harness, around biceps and around hood, ANSI 107 Class 3 Level 2.
- **1503C** 48" length coat, 3 piece hood-in-collar, 3M 2" reflective trim around chest, over-shoulder harness, around biceps and around hood, ANSI 107 Class 3 Level 2.

Following items come standard with: quick release suspender system, fly front with snap, Velcro® tab type leg cuff adjusters.

- **1501T** Bib style trouser, 3M 2" reflective trim around calves and knees, ANSI 107 Class E Level 2.

3M Scotchlite™
Reflective Material
NOMEX
only by DuPont

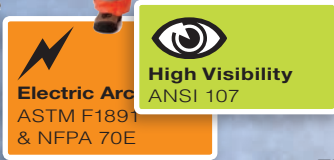

FLOURESCENT LIME YELLOW

NASCO	ITEM	SMALL	MEDIUM	LARGE	X-LARGE	2X-LARGE	3X-LARGE	4X-LARGE	5X-LARGE
1503JFY	JACKET	9702-21230	9000-50369	9000-50370	9000-50371	9000-70607	9701-83447	9703-66212	9703-53869
1501TFY	BIB TROUSER	9702-21231	9701-83448	9701-83449	9701-83450	9701-83451	9701-83452	9702-02670	9702-02671
1501PFY	PANT	9703-06545	9000-50372	9000-50373	9000-50374	9000-70609	9703-50250	9703-66218	9703-66219
1503CFY	COAT	9702-21229	9701-83902	9701-83903	9701-83904	9701-83905	9701-83906	9703-66220	9703-14266

FLOURESCENT ORANGE

NASCO	ITEM	SMALL	MEDIUM	LARGE	X-LARGE	2X-LARGE	3X-LARGE	4X-LARGE	5X-LARGE
1503JFO	JACKET	9703-66221	9703-30719	9703-30722	9702-41886	9703-31737	9702-41885	9703-66227	9703-66228
1501TFO	BIB TROUSER	9703-66229	9703-30724	9703-30725	9702-41888	9702-41887	9703-66234	9703-66235	9703-66236
1501PFO	PANT	9703-66237	9703-66238	9703-66239	9703-66240	9703-66241	9703-66242	9703-66243	9703-66244
1503CFO	COAT	9703-66245	9701-35034	9701-35036	9703-66246	9703-66247	9703-66248	9703-66249	9703-66250

Sentinel™

3M Scotchlite™
Reflective Material
NOMEX
only by DuPont

Sentinel™ excels in joining comfort with durability and protection. While keeping workers safe from electric arcs and flash fires, the durable Sentinel™ material extends the usable life and level of comfort well beyond other raingear.

Recommended Applications

- Electric & Gas Utilities
- Gas & Oil Extraction
- Oil Refining
- Electrical Maintenance
- Electrical Switching
- Meter Service
- Storm Restoration
- Tank Cleaning
- Arc and Flame Resistance
 - Does Not Melt, Drip, Ignite, or Break Open
 - Minimizes Heat Transfer Burns
- Flash Fire Resistance
 - Does Not Melt, Drip, Ignite, or Break Open
 - Minimizes Heat Transfer Burns
- Chemical Splash Resistance
- Waterproof
- Durable
- Soft, Flexible
- Long Life Cycle





Omega™ is the first waterproof, breathable outerwear product that combines high visibility worker conspicuity with protection from the thermal hazards associated with an electric arc flash and hydrocarbon flash fires. Omega is designed for today's rugged work environment.

- Removable Winter Liners Available
 - ANSI 107 Class 3 Compliant
 - Fall Protection Access
 - Stain & Soil Release
 - Electric Arc Resistance
 - Flash Fire Resistance
 - Waterproof
 - Breathable
 - Reduces Worker Heat Stress
 - Lightweight
 - Wind-Proof
 - Designed With Premier Features
- Recommended Applications:
- Gas & Electric Utility Transmission & Distribution
 - Telecommunication & CATV Workers
 - Storm Restoration
 - Electrical Maintenance
 - Meter Service
 - Electrical Switching

NOMEX
only by DuPont

3M Scotchlite™
Reflective Material

Thinsulate
INSULATION
FR

Omega 5000 Items 9 oz/yd² Omega FR outer Shell; Nomex® knit inside

Following items come standard with: hood-in-collar, nonconductive zipper front with Velcro storm fly front, fall protection access, 2 side entry pockets, tool belt slit with zippers, liner attachments, 3M Scotchlite 2" reflective trim around chest, shoulder harness and biceps.

● **5503JNFY** Navy/Fluorescent yellow waist length jacket.

Following items come standard with: Klein Tool pocket on right thigh, reinforced knees, non-conductive leg zippers with overfly, 3M Scotchlite 2" reflective trim at calf and ankles.

● **5001PFY** Fluorescent yellow elastic waist pant with drawstring, snap fly front.

● **5001TFY** Fluorescent yellow bib style trouser with snap fly front, quick release suspender self-material system.

Comfort
ASTM E96
& F1868

Electric Arc
ASTM F1891
& NFPA 70E

Flash Fire
ASTM F2733

High Visibility
ANSI 107

FLOURESCENT YELLOW/GREEN

NASCO	ITEM	SMALL	MEDIUM	LARGE	X-LARGE	2X-LARGE	3X-LARGE	4X-LARGE	5X-LARGE
5503JNFY	JACKET	9703-66251	9703-66252	9703-66253	9703-66254	9703-66255	9703-66256	9703-66257	9703-66258
5001TFY	BIB TROUSER	9703-66267	9703-66268	9703-66269	9703-66270	9703-66271	9703-66272	9703-66273	9703-66274
5001PFY	PANT	9703-66259	9703-66260	9703-66261	9703-66262	9703-66263	9703-66264	9703-66265	9703-66266

Jacket Size Chart

Bib/Trouser Size Chart

Size	Jacket Size Chart		Bib/Trouser Size Chart				
	Fits Chest Size	Actual Jacket Chest	Sleeve Length	Jacket Length	Fits Waist Size	Actual Overall Waist	Inseam Length
Small	36-38"	46"	33"	29"	32-34"	42"	29"
Medium	40-42"	50"	33.5"	29"	36-38"	46"	29"
Large	44-48"	54"	34"	29"	40-42"	50"	29"
X-Large	48-50"	58"	34.5"	29"	44-46"	54"	29"
2X-Large	52-54"	62"	35"	29"	48-50"	58"	29"
3X-Large	56-58"	66"	35.5"	29"	52-54"	62"	29"
4X-Large	60-62"	70"	36"	29"	56-58"	66"	29"
5X-Large	64-66"	74"	36.5"	29"	60-62"	70"	29"

Sentinel AR 4500 Series

Sentinel™ 4500 Items 10 oz/yd 100% Cotton Knit/Polyurethane

- **4503J** Waist length jacket, 3 piece hood-in-collar, non-conductive zipper front with Velcro® closure, Nomex® mesh ventilation system, fall protection access, Velcro® tab type wrist adjusters, two pockets with Velcro® closure, 3M Scotchlite™ 2" reflective trim, ANSI 107 Class 3 Level 2.
- **4503C** 48" coat, 3 piece hood-in-collar, non-conductive zipper front w/ Velcro closure, Nomex mesh ventilation, fall protection access, Velcro tab type wrist adjusters, 2 pockets w/ Velcro closure, 3M Scotchlite 2" reflective trim, ANSI 107 Class 3, Level 2.
- **4501T** Bib style trouser with quick release suspender system, fly front with snap, Velcro® tab type leg cuff adjusters, 3M 2" reflective trim around calves and knees, ANSI 107 Class E Level 2.
- **4501P** Elastic waist pant, fly front with snap, Velcro® tab type leg cuff adjusters, 3M 2" reflective trim around calves and knees, ANSI 107 Class E Level 2

Electric Arc
ASTM F1891
& NFPA 70E

High Visibility
ANSI 107

Flash Fire
ASTM F2733

FLOURESCENT YELLOW/GREEN

NASCO	ITEM	SMALL	MEDIUM	LARGE	X-LARGE	2X-LARGE	3X-LARGE	4X-LARGE	5X-LARGE
4503JFY	JACKET	9703-66275	9703-66276	9703-66277	9703-66278	9703-66279	9703-66280	9703-66281	9703-66282
4501TFY	BIB TROUSER	9703-66283	9703-66284	9703-66285	9703-66286	9703-66287	9703-66288	9703-66289	9703-66290
4501PFY	PANT	9703-66291	9703-66292	9703-66293	9703-66294	9703-66295	9703-66296	9703-66297	9703-66298

PERSONAL EQUIPMENT

**USA: 1-877-GO ALTEC
(1-877-462-5832)**

www.alteconnect.com





Hi-Vis 4-in-1 Bomber Jacket



- ANSI Class 3 When Worn With Zip-Off Sleeves!
- ANSI Class 2 When Wearing the Vest Only!
- ANSI Class 3 Inner Layer Hi-Vis Fleece Jacket

A high quality, water resistant, high visibility arc rated bomber that features a removable fleece liner, removable sleeves, and has all the same safety features as the shell - All for one price!

- HRC2, ATPV 9 cal/cm2 (electric arc flash rating)
- Meets NFPA 70E, ASTM D6413, ASTM F1930, and ANSI 107-2010, Class 3.

FLUORESCENT YELLOW - Sizes XS – 7X

Majestic	ITEM	SMALL	MEDIUM	LARGE	X-LARGE	2X-LARGE
91437Y	JACKET	9704-39477	9704-39478	9704-39479	9704-39480	9704-39481
93417Y	OVERALL	9704-39488	9704-39489	9704-39490	9704-39491	9704-39492

Majestic	ITEM	3X-LARGE	4X-LARGE	5X-LARGE	6X-LARGE	7X-LARGE
91437Y	JACKET	9704-39482	9704-39483	9704-39484	9704-39485	9704-39486
93417Y	OVERALL	9704-39493	9704-39494	9704-39495	9704-39496	9704-39497

P/N 9704-39498 91996 Zip-Off Hat (One Size Fits All)



BY MAJESTIC

TIRED OF
BLAZING HOT
FR CLOTHING?

TRY SOMETHING A LITTLE COOLER.

Blaze TEX® Vented Back FR Work Shirt

Using a FR modacrylic mesh under the arms and on the back, this shirt is a very comfortable option to wear in higher heat climates. The rest of the shirt is made with a 7 oz. 90% cotton 10% blend, which also provides for durability and breathability.

- HRC2, ATPV8.5 cal/cm2 (electric arc flash rating)
- Meets NFPA 1975-2004, NFPA 70E-2004, ASTM F 1506-02a, CAN/CGSB 155.20-2000, CAN/CGSB 155.22-97, et OSHA 29 CFR 1910.269, EN ISO 11611:2008, EN ISO 11612:2008, EN ISO 14116:2008 and UL certified NFPA 2112-2012.

Khaki - Sizes XS – 7X

Majestic	SMALL	MEDIUM	LARGE	X-LARGE	2X-LARGE
95761K	9704-91874	9704-91875	9704-91876	9704-91877	9704-91878

Majestic	3X-LARGE	4X-LARGE	5X-LARGE	6X-LARGE	7X-LARGE
95761K	9704-91880	9704-91881	9704-91882	9704-91883	9704-91884

NAVY - Sizes XS – 7X

Majestic	SMALL	MEDIUM	LARGE	X-LARGE	2X-LARGE
95761	9704-39500	9704-39501	9704-39502	9704-39503	9704-39504

Majestic	3X-LARGE	4X-LARGE	5X-LARGE	6X-LARGE	7X-LARGE
95761	9704-39505	9704-39506	9704-39507	9704-39508	9704-39509



Experience the Difference...





MAJESTIC
RELIABLE IN SAFETY

Hi-Vis Shirts & Vests

95627Y ANSI Class 2 Hi-Vis Short Sleeve T-Shirt

7.5 oz. 100% cotton short sleeve knit t-shirt, left chest pocket. Meets ANSI / ISEA Class 2 Standard. ATPV 8.6 CAL/CM²; HRC 2. Sizes M-X5

95637Y ANSI Class 3 Hi-Vis Long Sleeve T-Shirt

7.5 oz. 100% cotton short sleeve knit t-shirt, left chest pocket. Meets ANSI / ISEA Class 3 Standard. ATPV 8.6 CAL/CM²; HRC 2. Sizes M-X5

95811 ANSI Class 3 Hi-Vis Deluxe Button Down Long Sleeve Shirt, 3M FR Reflective

7 oz. High Visibility cotton. Vented button down collar and pleated back. Patch pockets on the chest with flap button closure and pen/pencil openings. 3M Flame Retardent reflective tape. Modacrylic mesh vented armpits and action allow for airflow and breathability. Meets ANSI / ISEA Class 3 Standard. ATPV 8.7 CAL/CM²; HRC 2. Sizes M-X6l and X1T-X3T.

95896 ANSI Class 2 Deluxe Mesh Safety Vest, D-ring Pass Through, ANSI Class 2

6.5 oz. 100% Modacrylic mesh vest. 2 inch 3M reflective tape. D-Ring pass-thru for fall protection. Velcro closure, outside waist patch pocket, inside left chest pen and cell phone pocket. Meets ANSI / ISEA Class 2 Standard. ATPV 5.1 CAL/CM²; HRC 1. Sizes M-X5

FLOURESCENT YELLOW - Sizes XS -5X

Majestic	ITEM	MEDIUM	LARGE	X-LARGE	2X-LARGE	3X-LARGE	4X-LARGE	5X-LARGE
95627Y	Short Sleeve Shirt	9706-37513	9706-37514	9706-37515	9706-37516	9706-37517	9706-37518	9706-37519
95637Y	Long Sleeve Shirt	9706-37520	9706-37521	9706-37522	9706-37523	9706-37524	9706-37525	9706-37526
95811	Button Down Shirt	9706-37527	9706-37528	9706-37529	9706-37530	9706-37531	9706-37532	9706-37533
95896	Safety Vest	9706-37534	9706-37535	9706-37536	9706-37537	9706-37538	9706-37539	9706-37540



PERSONAL EQUIPMENT

Experience the Difference...



Hi-Vis Jackets & Sweatshirts

95678 ANSI Class 3 Hi-Vis Full Zip-up Sweatshirt

11.5 oz. 100% cotton knit fleece. Two tone high visibility sweatshirt. 2 inch Flame Retardent reflective tape. Meets ANSI / ISEA Class 3 Standard. ATPV 19 CAL/CM²; HRC 2. Sizes M-X5

95658 ANSI Class 3 Hi-Vis Full Pull-Over Sweatshirt

11.5 oz. 100% cotton knit fleece. Two tone high visibility pull-over sweatshirt. 2 inch Flame Retardent reflective tape. Meets ANSI / ISEA Class 3 Standard. ATPV 19 CAL/CM²; HRC 2. Sizes M-X5

FLOURESCENT YELLOW - Sizes XS -5X

Majestic	ITEM	MEDIUM	LARGE	X-LARGE	2X-LARGE	3X-LARGE	4X-LARGE	5X-LARGE
95678	Zip-Front Sweatshirt	9706-37541	9706-37542	9706-37543	9706-37544	9706-37545	9706-37546	9706-37547
95658	Pull-Over Sweatshirt	9706-37548	9706-37549	9706-37550	9706-37551	9706-37552	9706-37553	9706-37554



USA: 1-877-GO ALTEC
(1-877-462-5832)

www.alteconnect.com



LEATHER LINEMAN BOOTS

DRI-LINE SERIES

10" Hoffman Dri-Line

Dual Steel Shanks for Climbing Support
Available in Plain or Steel Toe
Optional Steel Toe with EH Rating
Waterproof Liner
D, E, and EEE widths available
D: 7-12 with half sizes, 13-15
E & EEE: 8-12 with half sizes, 13

Model 10DL (Non-Steel Toe)
Model 10STDL (Steel Toe)

PROUDLY MADE IN THE



The 10" Dri-Line was built to keep your feet dry inside when conditions are wet on the outside. A highly advanced Sympatex waterproof membrane keeps water out and adds cushion and comfort to the boot. For climbing, our dual steel shanks are added to provide the extra arch support needed. Other quality features include a 7-7 1/2 oil tanned leather upper that provides support to your legs. A climber side patch, solid brass hooks and eyelets, supportive heel counter, Vibram lug sole and three rows of durable stitching help prolong the life of the boot. For those looking for a quality waterproof climbing boot, look no further.

PLAIN TOE

10" Hoffman Dri-Line

Model 10DL (Non-Steel Toe)

SIZE	D WIDTH (AVERAGE)	E WIDTH (WIDE)	EEE WIDTH (EXTRA WIDE)
7	9000-70660	9704-00065	-
7.5	9702-61111	9704-00066	-
8	9702-58504	9704-00067	9704-00104
8.5	9000-70311	9000-70659	9704-00105
9	9000-70344	9704-00068	9704-00106
9.5	9000-70312	9701-76191	9704-00107
10	9000-70592	9702-07169	9704-00108
10.5	9000-70571	9000-70308	9704-00109
11	9000-70657	9704-00069	9704-00110
11.5	9000-70310	9000-70309	9704-00111
12	9000-70343	9703-18050	9704-00112
13	9000-70658	9702-05742	9704-00113
14	9702-05741	-	-
15	9702-81083	-	-

STEEL TOE

10" Hoffman Dri-Line

Model 10STDL (Steel Toe)

SIZE	D WIDTH (AVERAGE)	E WIDTH (WIDE)	EEE WIDTH (EXTRA WIDE)
7	9704-00070	9704-00071	-
7.5	9704-00072	9704-00073	-
8	9704-00074	9704-00075	9704-00076
8.5	9704-00077	9704-00078	9704-00079
9	9704-00080	9704-00081	9704-00082
9.5	9704-00083	9704-00084	9704-00085
10	9704-00086	9704-00087	9704-00088
10.5	9704-00089	9704-00090	9704-00091
11	9704-00092	9704-00093	9704-00094
11.5	9704-00095	9704-00096	9704-00097
12	9704-00098	9704-00099	9704-00100
13	9704-00101	9704-00102	9704-00103
14	9704-00301	-	-
15	9704-00302	-	-

LEATHER LINEMAN BOOTS

POWERLINE SERIES

10" Hoffman PowerLine (Steel Toe Optional)

The new 10" Powerline combines the comfort and fit of our 6" hiker with the support and feel of a regular work boot. The 10" Powerline features a leather/Cordura upper for lighter weight and breathability. The waterproof insert provides a waterproof barrier that helps keep you dry no matter what the weather is doing. A full cushion insole and padded leather collar add all-day comfort. We also added Hoffman's unique dual steel shank system that provides more climbing support than any boot on the market. For those needing a steel toe boot, the Powerline is available in both steel toe and plain toe. A Vibram sole provides long term wear and excellent traction. Try a pair of the highly anticipated 10" Powerline boots and see for yourself what all the hype is about!

NOTE: The Powerline has a waterproof liner. Although waterproof failure is rare in the construction of this boot, Hoffman's will not warranty the waterproofness of this boot.



PERSONAL EQUIPMENT



PROUDLY MADE IN THE



Model LPower (Non-Steel Toe)
Model STPower (Steel Toe)

Dual Steel Shanks for Climbing Support
Available in EH upon Request
Available in Plain or Steel Toe
Leather/Cordura Upper for Lighter Weight
D and EE widths available
D: 7-12 with half sizes, 13, 14
EE: 8-12 with half sizes, 13

USA: 1-877-GO ALTEC
(1-877-462-5832)

PLAIN TOE

10" Hoffman PowerLine Model LPower (Non-Steel Toe)

SIZE	D WIDTH (AVERAGE)	EE WIDTH (EXTRA WIDE)
7	9704-00290	-
7.5	9704-00291	-
8	9704-00292	9704-00303
8.5	9704-00293	9704-00304
9	9703-30156	9704-00305
9.5	9704-00294	9704-00306
10	9704-00295	9704-00307
10.5	9704-00296	9704-00308
11	9704-00297	9704-00309
11.5	9704-00298	9704-00310
12	9703-30151	9704-00311
13	9704-00299	9704-00312
14	9704-00300	-

STEEL TOE

10" Hoffman PowerLine Model STPower (Steel Toe)

SIZE	D WIDTH (AVERAGE)	EE WIDTH (EXTRA WIDE)
7	9704-00313	-
7.5	9704-00314	-
8	9704-00315	9704-00327
8.5	9704-00316	9704-00328
9	9704-00317	9704-00329
9.5	9704-00318	9704-00330
10	9704-00319	9704-00331
10.5	9704-00320	9704-00332
11	9703-94180	9704-00333
11.5	9704-00321	9704-00334
12	9704-00322	9704-00335
13	9704-00323	9704-00336
14	9704-00324	-

www.alteconnect.com



LEATHER LINEMAN BOOTS

10" ALL LEATHER POWERLINE

All-Leather Upper for Additional Ankle Support
 Available in EH upon Request
 Available in Plain or Safety Toe (ASTM F2413-05)
 Dual Steel Shanks for Climbing Support
 D and EE widths available
 D: 7-12 with half sizes, 13, 14
 EE: 8-12 with half sizes, 13



We are pleased to bring you our NEW 10" Steel Toe All-Leather Powerline boot for linemen who want an all leather upper with outstanding support and all the bells and whistles. Our Hoffman All Leather Powerline offers many features found on our other line boots. A double midsole combined with our DUAL STEEL SHANKS provide plenty of climbing support. A rebuildable vibram lug sole provides excellent wear and an added climbing heel adds climbing safety. A waterproof liner will help keep you dry no matter what the weather is doing. A cushion insole is included with every pair. If you like our lineman hikers or need a similar boot with a taller top, this boot is for you.

NOTE: The Powerline has a waterproof liner. Although waterproof failure is rare in the construction of this boot, Hoffman's will not warranty the waterproofness of this boot.

PROUDLY MADE IN THE



Model 600LeatherPow (Non-Safety Toe)
 Model 600STLeatherPow (Safety Toe)

10" All Leather Powerline WITHOUT SAFETY TOE

Model 600LeatherPow (Non-Safety Toe)

SIZE	D WIDTH (AVERAGE)	EE WIDTH (WIDE)
7	9704-00241	-
7.5	9704-00242	-
8	9704-00243	9704-00256
8.5	9704-00244	9704-00257
9	9704-00245	9704-00258
9.5	9704-00246	9704-00259
10	9704-00247	9704-00260
10.5	9704-00248	9704-00261
11	9704-00249	9704-00262
11.5	9704-00250	9704-00263
12	9704-00251	9704-00264
13	9704-00252	9704-00265
14	9704-00253	-

10" Steel Toe All Leather Powerline WITH SAFETY TOE

Model 600STLeatherPow (Safety Toe)

SIZE	D WIDTH (AVERAGE)	EE WIDTH (WIDE)
7	9704-00216	-
7.5	9704-00217	-
8	9704-00218	9704-00231
8.5	9704-00219	9704-00232
9	9704-00220	9704-00233
9.5	9704-00221	9704-00234
10	9704-00222	9704-00235
10.5	9704-00223	9704-00236
11	9704-00224	9704-00237
11.5	9704-00225	9704-00238
12	9704-00226	9704-00239
13	9704-00227	9704-00240
14	9704-00228	-

THINSULATE® LINEMAN PAC

Our Thinsulate Lineman Pac has become very popular with those who work in the milder weather condition. Lined with a removable Thinsulate/wool/cambrelle liner, this boot is an excellent choice for those looking for a slimmer alternative to felt pacs. Equipped with our dual steel shanks, the Thinsulate Lineman Pac provides your arches with support unmatched by any other lineman boot of its kind. Our 100% handmade waterproof bottom has an added layer of polyester and polyamid incorporated in the pure natural rubber to resist cracking and extend the life of the boot. If you're a lineman who works in slushy, cool conditions, this boot was made for you. Come standard with a claw-lug sole. Vibram sole available.

FITTING TIPS: Hoffman Thinsulate Pacs tend to run small. Add 1 size to your current shoe size. (i.e.: size 9 or 9 1/2 would order a size 10).

Model L12 (Non-Steel Toe)
Model LST12 (Steel Toe)

Dual Steel Shanks for Climbing Support
 Thinsulate Liner for Mild Conditions
 Industrial Grade Rubber Bottoms
 Rebuildable for years of service
 Available in 10", 12", and 14" Heights
 Plain Toe: Sizes 6-14 (whole sizes only)
 Steel Toe: Sizes 7-14 (whole sizes only)

PROUDLY MADE IN THE



PLAIN TOE Thinsulate® Lineman Pac

Model L12 (Non-Steel Toe)

FITTING TIPS: Hoffman Thinsulate Pacs tend to run small. Add 1 size to your current shoe size. (i.e.: size 9 or 9 1/2 would order a size 10)

SIZE	10" Height	12" Height	14" Height
6	9704-00189	9704-00198	9704-00207
7	9704-00190	9704-00199	9704-00208
8	9704-00191	9704-00200	9704-00209
9	9704-00192	9704-00201	9704-00210
10	9704-00193	9704-00202	9704-00211
11	9704-00194	9704-00203	9704-00212
12	9704-00195	9704-00204	9704-00213
13	9704-00196	9704-00205	9704-00214
14	9704-00197	9704-00206	9704-00215

STEEL TOE Thinsulate® Lineman Pac

Model LST12 (Steel Toe)

FITTING TIPS: Hoffman Thinsulate Pacs tend to run small. Add 1 size to your current shoe size. (i.e.: size 9 or 9 1/2 would order a size 10)

SIZE	10" Height	12" Height	14" Height
6	-	-	-
7	9704-00266	9704-00274	9704-00282
8	9704-00267	9704-00275	9704-00283
9	9704-00268	9704-00276	9704-00284
10	9704-00269	9704-00277	9704-00285
11	9704-00270	9704-00278	9704-00286
12	9704-00271	9704-00279	9704-00287
13	9704-00272	9704-00280	9704-00288
14	9704-00273	9704-00281	9704-00289

PERSONAL EQUIPMENT

USA: 1-877-GO ALTEC
(1-877-462-5832)

www.alteconnect.com



HOFFMAN FELT LINEMAN PACS

PLAIN TOE LINEMAN FELT PACS

Renown for its overall performance, durability and warmth, the Hoffman Lineman Felt Pac is the best selling lineman pac boot in America. Constructed with an industrial grade rubber bottoms, our pacs resist cracking and premature rebuilds associated with other boots. Dual steel shanks, including a 5" triple ribbed shank, and a 12 iron midsole offer unsurpassed support for those standing on rungs or crossbars. The popular claw-lug sole offers outstanding traction in all weather conditions. Try a pair of our Hoffman Lineman Felt Pacs and you'll see why our customers tell us that their Hoffman Pac Boots are the most comfortable and supportive boots they own. Made in USA.

Model L13 (Non-Steel Toe)
Dual Steel Shanks for Climbing Support
9MM Removable Felt Liner for Cold Conditions
Plain Toe Reinforced Rubber Bottom
Rebuildable for years of service
Available in 10", 12", and 14" Heights
Sizes 6-15 (whole sizes only)



FITTING TIPS: Hoffman felt pacs run true to size. Whole size: order the same. Half size: order down (i.e.: 9 1/2 would order 9) unless you have a wide foot.

PROUDLY MADE IN THE



PLAIN TOE Lineman Felt Pac

Model L13 (Non-Steel Toe)

FITTING TIPS: Hoffman felt pacs run true to size. Whole size: order the same. Half size - Order down (i.e.: 9 1/2 would order 9) - unless you have a wide foot.

SIZE	10" Height	12" Height	14" Height
6	9704-00114	9704-00124	9704-00133
7	9704-00115	9704-00125	9704-00134
8	9704-00116	9704-00126	9703-41605
9	9704-00117	9704-00127	9702-72814
10	9704-00118	9703-49826	9702-22691
11	9704-00119	9704-00128	9704-00135
12	9704-00120	9704-00129	9704-00136
13	9704-00121	9704-00130	9704-00137
14	9704-00122	9704-00131	9704-00138
15	9704-00123	9704-00132	9704-00139

STEEL TOE LINEMAN FELT PACS

Some jobs require a steel toe for added safety. The Highline Steel Toe Felt Pac meets this need. This boot has many of the same features of the Hoffman Lineman Felt Pac including our dual steel shank system that adds the most arch support of any lineman boot available. The waterproof rubber bottom includes a steel toe that meets or exceeds the safety standard requirements of the ASTM. Like all of our boots, the Highline Steel Toe Felt Pac is rebuildable for years of service-something you've come to expect from Hoffman's. ASTM Steel Toe (Z41 Pt 91, MI-75 C-75).

FITTING TIPS: Hoffman felt pacs run true to size. Whole size-order the same. Half size-Order down (i.e.: 9 1/2 would order 9) unless you have a wide foot.

Model L14 (Steel Toe)
Dual Steel Shanks for Climbing Support
9MM Removable Felt Liner for Cold Conditions
Steel Toe Reinforced Rubber Bottom
Rebuildable for years of service
Available in 10", 12", and 14" Heights
Sizes 7-15 (whole sizes only)

PROUDLY MADE IN THE



STEEL TOE Lineman Felt Pac

Model L14 (Steel Toe)

FITTING TIPS: Hoffman felt pacs run true to size. Whole size-order the same. Half size - Order down (i.e.: 9 1/2 would order 9) - unless you have a wide foot.

SIZE	10" Height	12" Height	14" Height
7	9704-00140	9704-00147	9704-00156
8	9704-00141	9704-00148	9704-00157
9	9703-39650	9704-00149	9704-00158
10	9704-00142	9704-00150	9704-00159
11	9703-95851	9704-00151	9704-00160
12	9704-00143	9704-00152	9704-00161
13	9704-00144	9704-00153	9704-00162
14	9704-00145	9704-00154	9704-00163
15	9704-00146	9704-00155	9704-00164

HOFFMAN FELT LINEMAN PACS

EH STEEL TOE LINEMAN FELT PACS



PROUDLY MADE IN THE



Some employers now require their workers to have a boot that meets EH standards. Our new EH Lineman Pac has all the features of the Highline Steel Toe Felt Pac with the addition of a sole combination that meets the EH standards. Our dual steel shanks, heavy leather uppers and quality components are still standard. For those of you who need a boot that is Electrical Hazard approved, our new EH Lineman Pac fits the bill.

FITTING TIPS: Hoffman felt pacs run true to size. Whole size - order the same. Half size - Order down (i.e.: 9 1/2 would order 9) unless you have a wide foot.

Model EHPAC (Steel Toe)

- EH approved Sole
- Dual Steel Shanks for Climbing Support
- 9MM Removable Felt Liner for Cold Conditions
- Steel Toe Reinforced Rubber Bottom
- Rebuildable for years of service
- Available in 10", 12", and 14" Heights
- Sizes 7-14 (whole sizes only)

STEEL TOE EH Steel Toe Lineman Pac

Model EHPAC (Steel Toe)

FITTING TIPS: Hoffman felt pacs run true to size. Whole size-order the same. Half size - Order down (i.e.: 9 1/2 would order 9) - unless you have a wide foot.

SIZE	10" Height	12" Height	14" Height
7	9704-00165	9704-00173	9704-00181
8	9704-00166	9704-00174	9704-00182
9	9704-00167	9704-00175	9704-00183
10	9704-00168	9704-00176	9704-00184
11	9704-00169	9704-00177	9704-00185
12	9704-00170	9704-00178	9704-00186
13	9704-00171	9704-00179	9704-00187
14	9704-00172	9704-00180	9704-00188

PERSONAL EQUIPMENT

USA: 1-877-GO ALTEC
(1-877-462-5832)

www.alteconnect.com



SINCE 1918

WESCO HIGHLINERS 10" SEMI LACE-TO-TOE

Rugged comfort for professional linemen and arborists. Special construction resists climbing spurs and foot fatigue.

STYLE CST5710 #430 VIBRAM SOLE, COMPOSITE TOE



- 7 oz. full-grain leather
- Leather side flap
- Non-corrosive, ribbed, slightly arched steel shank for comfort and maximum support
- Leather 10 - 10-1/2 iron (.219" thick) half-slip for added support in the arch
- Recessed metal heel breastplate (offers protection from climbing spurs)
- Steel sideplate
- Removable false tongue

PROUDLY MADE IN THE



BLACK, 10" HEIGHT SEMI LACE-TO-TOE COMPOSITE TOE #430 VIBRAM SOLE STYLE CST5710

SIZE	D Width	E Width
8	9704-05869	9704-05879
8.5	9704-05870	9704-05880
9	9701-05871	9704-05881
9.5	9704-05872	9704-05882
10	9704-05873	9704-05883
10.5	9704-05874	9704-05884
11	9704-05875	9704-05885
11.5	9704-05876	9704-05886
12	9704-05877	9704-05887
13	9704-05878	9704-05888

STYLE ST5710100 #100 VIBRAM SOLE, STEEL TOE



- 7 oz. full-grain leather
- Leather side flap
- Non-corrosive, ribbed, slightly arched steel shank for comfort and maximum support
- Leather 10 - 10-1/2 iron (.219" thick) half-slip for added support in the arch
- Recessed metal heel breastplate (offers protection from climbing spurs)
- Steel sideplate not available with #100 Vibram® sole
- Removable false tongue

PROUDLY MADE IN THE



BLACK, 10" HEIGHT SEMI LACE-TO-TOE STEEL TOE #100 VIBRAM SOLE STYLE ST5710100

SIZE	D Width	E Width
8	9704-05889	9704-05899
8.5	9704-05890	9704-05900
9	9704-05891	9704-05901
9.5	9704-05892	9704-05902
10	9704-05893	9704-05903
10.5	9704-05894	9704-05904
11	9704-05895	9704-05905
11.5	9704-05896	9704-05906
12	9704-05897	9704-05907
13	9704-05898	9704-05908

PERSONAL EQUIPMENT

USA: 1-877-GO ALTEC
(1-877-462-5832)

www.alteconnect.com



SINCE 1918

WESCO HIGHLINERS 10" HEIGHT LACE-TO-TOE



STYLE 9710 #430 VIBRAM SOLE, PLAIN TOE

- 7 oz. full-grain leather
- Leather side flap
- Non-corrosive, ribbed, slightly arched steel shank for comfort and maximum support
- Leather 10 - 10-1/2 iron (.219" thick) half-slip for added support in the arch
- Recessed metal heel breastplate (offers protection from climbing spurs)
- Steel sideplate
- Removable false tongue

PROUDLY MADE IN THE



BLACK, 10" HEIGHT LACE-TO-TOE PLAIN TOE #430 VIBRAM SOLE STYLE 9710

SIZE	D Width	E Width
8	9704-05909	9704-05919
8.5	9704-05910	9701-59705
9	9704-05911	9704-05920
9.5	9704-05912	9701-59418
10	9704-05913	9704-05921
10.5	9704-05914	9704-05922
11	9704-05915	9704-05923
11.5	9704-05916	9704-05924
12	9704-05917	9703-59417
13	9704-05918	9704-05925

STYLE 9710100 #100 VIBRAM SOLE, PLAIN TOE

- 7 oz. full-grain leather
- Leather side flap
- Non-corrosive, ribbed, slightly arched steel shank for comfort and maximum support
- Leather 10 - 10-1/2 iron (.219" thick) half-slip for added support in the arch
- Recessed metal heel breastplate (offers protection from climbing spurs)
- Steel sideplate not available with #100 Vibram® sole
- Removable false tongue

PROUDLY MADE IN THE



BLACK, 10" HEIGHT LACE-TO-TOE PLAIN TOE, #100 VIBRAM SOLE STYLE 9710100

SIZE	D Width	E Width	EE Width
8	9704-05926	9704-05936	9704-05946
8.5	9704-05927	9704-05937	9704-05947
9	9704-05928	9704-05938	9704-05948
9.5	9704-05929	9704-05939	9704-05949
10	9704-05930	9704-05940	9704-05950
10.5	9704-05931	9704-05941	9704-05951
11	9704-05932	9704-05942	9704-05952
11.5	9704-05933	9704-05943	9704-05953
12	9704-05934	9704-05944	9704-05954
13	9704-05935	9704-05945	9704-05955



PERSONAL EQUIPMENT

USA: 1-877-GO ALTEC
(1-877-462-5832)

www.alteconnect.com



SINCE 1918

WESCO HIGHLINERS 16" HEIGHT LACE-TO-TOE

PERSONAL EQUIPMENT

USA: 1-877-GO ALTEC
(1-877-462-5832)

www.alteconnect.com



STYLE 9716

#430 VIBRAM SOLE, PLAIN TOE

- 7 oz. full-grain leather
- Leather side flap
- Non-corrosive, ribbed, slightly arched steel shank for comfort and maximum support
- Leather 10 - 10-1/2 iron (.219" thick) half-slip for added support in the arch
- Recessed metal heel breastplate (offers protection from climbing spurs)
- Steel sideplate
- Removable false tongue

PROUDLY MADE IN THE



BLACK, 16" HEIGHT LACE-TO-TOE PLAIN TOE #430 VIBRAM SOLE STYLE 9716

SIZE	D Width	E Width
8	9704-05956	9704-05966
8.5	9704-05957	9704-05967
9	9701-93904	9704-05968
9.5	9704-05959	9704-05969
10	9704-05960	9704-05970
10.5	9704-05961	9704-05971
11	9704-05962	9704-05972
11.5	9704-05963	9704-05973
12	9704-05964	9704-05974
13	9704-05965	9704-05975



STYLE 9716100

#100 VIBRAM SOLE, PLAIN TOE

- 7 oz. full-grain leather
- Leather side flap
- Non-corrosive, ribbed, slightly arched steel shank for comfort and maximum support
- Leather 10 - 10-1/2 iron (.219" thick) half-slip for added support in the arch
- Recessed metal heel breastplate (offers protection from climbing spurs)
- Steel sideplate not available with #100 Vibram® sole
- Removable false tongue

PROUDLY MADE IN THE



BLACK, 16" HEIGHT LACE-TO-TOE PLAIN TOE #100 VIBRAM SOLE STYLE 9716100

SIZE	D Width	E Width
7	Please Call	9703-28514
8	9701-95014	9704-05982
8.5	9704-05976	9704-05983
9	9704-05977	9704-05984
9.5	9702-56215	9704-05985
10	9702-80063	9701-89230
10.5	9702-66305	9704-05986
11	9704-05978	9704-05987
11.5	9704-05979	9704-05988
12	9704-05980	9704-05989
13	9704-05981	9704-05990
14	Please Call	Please Call
15	Please Call	9702-61773



THE BOSS BOOT 11" HEIGHT

STYLE 7700100 #100 VIBRAM SOLE, HARD TOE



- Rolled-leather top facing
- Permanently formed Stytherm™ counter
- PORON® performance shock absorbing removable cushion inserts (F-Firm) 20 lb. density with black Cambrelle® lining
- Leather heel base
- Non-corrosive, ribbed, slightly arched steel shank
- Full-leather vamp lined with leather
- Hard toe
- Sweat-resistant full-leather insole
- Full-leather midsole

PROUDLY MADE IN THE



BLACK, 11" HEIGHT HARD TOE #100 VIBRAM SOLE STYLE 7700100

SIZE	D Width	E Width
8	9704-05992	9704-06002
8.5	9704-05993	9704-06003
9	9704-05994	9704-06004
9.5	9704-05995	9704-06005
10	9704-05996	9704-06006
10.5	9704-05997	9704-06007
11	9704-05998	9704-06008
11.5	9704-05999	9704-06009
12	9704-06000	9704-06010
13	9704-06001	9704-06011

THE JOBMASTER 10" HEIGHT

STYLE 110100 #100 VIBRAM SOLE



- 7 oz. full-grain leather
- Sturdy Vibram® sole and heel
- One of the most versatile boots Wesco makes
- Removable false tongue

PROUDLY MADE IN THE



BLACK, 10" HEIGHT LACE-TO-TOE #100 VIBRAM SOLE STYLE 7700100

SIZE	D Width	E Width	EE Width
8	9704-06012	9704-06022	9704-06032
8.5	9704-06013	9704-06023	9704-06033
9	9704-06014	9704-06024	9704-06034
9.5	9704-06015	9704-06025	9704-06035
10	9704-06016	9704-06026	9704-06036
10.5	9704-06017	9704-06027	9704-06037
11	9704-06018	9704-06028	9704-06038
11.5	9704-06019	9704-06029	9704-06039
12	9704-06020	9704-06030	9704-06040
13	9704-06021	9704-06031	9704-06041

Please call 1-877-GO ALTEC (1-877-462-5823) for additional information on ordering the Jobmaster in Brown or Redwood.

PERSONAL EQUIPMENT

USA: 1-877-GO ALTEC
(1-877-462-5832)

www.alteconnect.com

TINGLEY

A TRADITION SINCE 1896

OVERSHOES & BOOTS



STEEL TOE PVC OVERSHOES

Protects the User's Toes & Shoes!

- Tingley Rubber has produced the industry's first injection molded PVC steel toe overshoe
- Made to fit snug over most shoe styles, our 100% waterproof seamless construction protects shoes from damage caused by site chemicals, contaminants, and wear
- Molded in oversized toe cap accommodates most shoe styles and exceeds ASTM F 2413-05 M/1/75/C/75
- Injection molded 100% waterproof protection
- Easily slips on over the bulkiest work shoes. Pull on tab and heel kicker for easy on/off
- No hardware to conduct, tear, or snag, which helps prevent slips and falls
- Injection molded for more material in high wear point areas and less material in the upper to reduce weight
- Special Frigiflex® PVC compound provides long wear, and flexibility in cold temperatures
- "ShoeLocks" molded into the vamp and above the heel counter help insure a proper fit for a variety of footwear styles

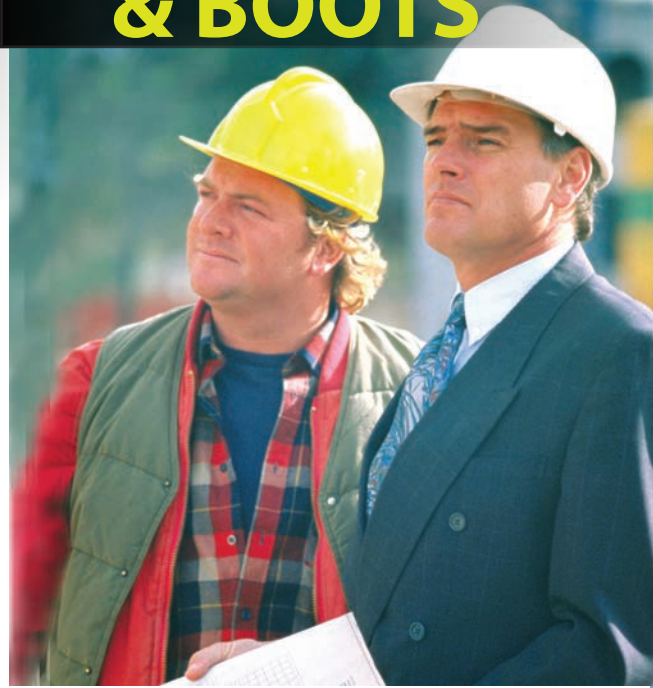

TINGLEY DESCRIPTION	Size XSmall	Size Small	Size Medium	Size Large	Size X-Large	Size 2X-Large
35211 Steel Toe Overshoe	9705-88695	9705-88696	9705-88697	9705-88698	9705-88699	9705-88700



Work Comfortably in the *Toughest* Conditions

WORK RUBBER OVERSHOES

- Excellent tensile strength, ease of stretch and tear resistance for more durability, better comfort and easier on and off
- Will not crack or stiffen in the coldest of weather
- Deep cleated outsole spits out debris for good slip resistance and longer wear
- Heavy duty heel kick off cleat for easy no hands removal
- Sturdy molded in rubber button on boot styles, for secure closure. No hardware to conduct, tear, or snag
- No lining for easy cleaning and decontamination
- More material in heel, toe, and sole for longer wear
- Less material in the upper results in lighter weight and reduced leg fatigue
- **Available in sizes Small - 3X**

TINGLEY DESCRIPTION	Size Small	Size Medium	Size Large	Size X-Large	Size 2X-Large	Size 3X-Large
1300 Hi-Top Work Shoe	9703-46586	9703-46587	9703-46588	9703-46589	9703-46590	9703-46591
1400 10" Work Boot	9703-46592	9703-46593	9703-46594	9703-46595	9703-46596	9703-46597

ECONOMY PVC BOOTS

- Injection molded construction for 100% waterproof protection
- Flexible upper material stays supple in cold temperatures to make walking easier
- Tougher outsole material for good abrasion resistance
- Steel toe meets ASTM 2413 M/1/75/C/75
- Self cleaning cleated outsole, spits out debris for good traction
- Removable EVA contour insole provides a comfortable foot bed
- **31151: Available in sizes 4-14 (even sizes); 31251 Available in sizes 4-14 (even sizes)**

Even Tingley's Economy Boots meet their high standard for quality and performance!

Black, Plain Toe Economy PVC Boots

P/N 9703-46604	31151 - Size 9
P/N 9703-46605	31151 - Size 10
P/N 9703-46606	31151 - Size 11
P/N 9703-46607	31151 - Size 12
P/N 9703-46608	31151 - Size 13
P/N 9703-46609	31151 - Size 14

Black, Steel Toe Economy PVC Boots

P/N 9703-46610	31251 - Size 9
P/N 9703-46611	31251 - Size 10
P/N 9703-46612	31251 - Size 11
P/N 9703-46613	31251 - Size 12
P/N 9703-46614	31251 - Size 13
P/N 9703-46615	31251 - Size 14





MK8 EVOLUTION™ THE STRONGEST INDUSTRIAL SAFETY HELMET IN THE WORLD



The MK8 Evolution™ meets the ANSI Z89.1-2009 standard for Type II impact protection. However, it is also the only industrial safety helmet in the world at this time meeting and exceeding the new, tougher European standard EN14052, the biggest advance in industrial head protection in over 45 years. But most importantly, MK8 Evolution™ provides protection from SIDE IMPACTS and SIDE PENETRATION to the same level as ANSI Z89.1 Type I testing, with almost 20 times the coverage area.

- Meets ANSI/ISEA Z89.1-2009, Type II, Class E requirements
- Offers Side (Lateral) Impact Protection which reduces the force of impact resulting from a blow which may be received off center as well as to the top of the head
- Also offers Side Penetration Protection in addition to crown penetration
- Expanded Polystyrene (EPS) Impact Liner helps absorb the forces of impact
- Deluxe Polyester Textile Strap Suspension with microfiber crown pad webbing
- Wheel Ratchet Adjustment allows user to easily adjust fit while wearing
- High-Density Polyethylene (HDPE) Shell and Universal Accessory Slots

P/N 9704-96985 280-AHS150-10 White (Min. Order Qty of 8)
P/N 9704-96986 280-AHS150-10 White with Altec Logo

MK8 Evolution™ Linesman Hard Hat

ALL the Features of the MK8 Evolution Plus a 4-Point Chin Strap

P/N 9704-96987 280-AHS240-10 White (Min. Order Qty of 8)
P/N 9704-96988 280-AHS240-10 White with Altec Logo



EVOLUTION™ 6100 Hard Hats



Full Brim Style

- High-Density Polyethylene (HDPE) shell with a full brim providing additional protection against sun, glare, rain and falling debris
- Extended back brim helps protect neck and ears from the sun's UV rays, as well as a run-off for rain and snow...short front brim shades the face while allowing excellent visibility
- Brim includes finger grips on front and rear, as well as a textured underside to reduce reflection/glare
- EasyJust™ slip ratchet is simple to adjust and an improved alternative to the traditional pin-lock system
- 6-Point suspension system with polyester textile straps offers unrivalled comfort without compromising performance
- Unique "3D Adjustment" provides a precise fit using harness depth settings... unlike any other hard hat on the US market today

- Evolution Wheel Ratchet is easy to use and creates a firm comfortable fit
- Chamlon™ sweatband for maximum sweat absorption
- Vented versions are available to reduce inside helmet temperatures... ANSI Class C
- Universal slots to fit various accessories
- Packed ready-to-wear with no installation of the suspension required
- Meets ANSI/ISEA Z89.1-2009, Type I, Class E requirements

Full Brim Style

P/N 9704-96989 280-EV6141-10 White, Slip Ratchet
P/N 9704-96990 280-EV6141V-10 White, Slip Ratchet; Vented
P/N 9704-96991 280-EV6161-10 White, Wheel Ratchet
P/N 9704-96992 280-EV6161V-10 White, Wheel Ratchet; Vented

Cap Style

P/N 9704-96993 280-EV6121-10 White, Slip Ratchet
P/N 9704-96994 280-EV6121V-10 White, Slip Ratchet; Vented
P/N 9704-96995 280-EV6151-10 White, Wheel Ratchet
P/N 9704-96996 280-EV6151V-10 White, Wheel Ratchet; Vented
P/N 9704-97783 280-EV6151-10-ALTEC White, Wheel Ratchet; Vented, Altec Logo



Cap Style

PERSONAL EQUIPMENT

USA: 1-877-GO ALTEC
(1-877-462-5832)

www.alteconnect.com



PROTECTIVE INDUSTRIAL PRODUCTS

INDUSTRIAL HAND PROTECTION

PERSONAL EQUIPMENT

USA: 1-877-GO ALTEC
(1-877-462-5832)

www.alteconnect.com

POLYURETHANE GRIP GLOVES WITH DYNEEMA®

All Gloves from PIP Are Sold By the Dozen

Stronger Than STEEL



- Gloves are washable, improving their longevity
- Seamless knit construction provides comfort without sacrificing dexterity
- Silicone free
- Color coded hems provide easy size identification
- Made from Spun Dyneema®, with Lycra® or Nylon-plated styles available
- Available with coated palm and knuckles or coated palm and finger tips, light or medium weight
- Superior puncture and abrasion resistance

- Great White™, Gray Coating, EN Cut Level 3
- P/N 9704-44090 19-D622-XS
 - P/N 9704-44091 19-D622-S
 - P/N 9704-44092 19-D622-M
 - P/N 9704-44093 19-D622-L
 - P/N 9704-44094 19-D622-XL
 - P/N 9704-44095 19-D622-XXL

POLYURETHANE GRIP GLOVES WITH KEVLAR®

- Kevlar® yarn is designed to be cut resistant
- Seamless knit construction protects hands without sacrificing comfort or dexterity
- Kevlar® will not melt, ignite or conduct electricity
- Polyurethane coated for added abrasion resistance
- Color coded hems for easy size identification
- Dupont Kevlar® brand fiber provides high tensile strength relative to its weight - up to five times stronger than steel

Kevlar® and Lycra blend, polyurethane coated palm and fingers, 15 gauge, light weight, EN Cut Level 2

- P/N 9704-44096 09-K1250-S
- P/N 9704-44097 09-K1250-M
- P/N 9704-44098 09-K1250-L
- P/N 9704-44099 09-K1250-XL
- P/N 9704-44100 09-K1250-XXL



HI-VIS COATED ACRYLIC GLOVE ~LATEX MICROFINISH® GRIP



- Seamless construction for comfortable fit
- Excellent thermal insulation
- Quickly evaporates moisture from the skin
- Extra softness for non-chafing comfort
- Excellent launderability characteristics

Hi-Vis Orange Acrylic Terry Shell, Brown MicroFinish Grip

- P/N 9704-44107 41-1400-S
- P/N 9704-44108 41-1400-M
- P/N 9704-44109 41-1400-L
- P/N 9704-44110 41-1400-XL
- P/N 9704-44111 41-1400-XXL

HIGH PERFORMANCE UTILITY GLOVE

- FR-treated synthetic leather
- Wing thumb and reinforced palm
- Lined with Kevlar brand fiber
- Ideal for hot, heavy material handling, stamping, grinding, cut-resistance, and multi-task applications where welding could be part of the task

- P/N 9704-44112 73-1703-S
- P/N 9704-44113 73-1703-M
- P/N 9704-44114 73-1703-L
- P/N 9704-44115 73-1703-XL
- P/N 9704-44116 73-1703-XXL
- P/N 9704-44117 73-1703-XXXL





Bringing the Best
of the World to You!®

G-TEK® MAXIFLEX ENDURANCE™

- Ultra-lightweight, knitwrist, Micro-Foam nitrile coated glove
- AirTech® technology delivers 360° breathability
- Raised Micro Dots to increase durability and cushioning
- Minimal palm thickness and thinner than most comparable gloves
- Class leading form, fit and feel, reducing hand fatigue and increased comfort
- 25% thinner than most comparable gloves

Black Micro-Foam Coated Palm, Full Fingers,
and 3/4 Knuckles with Micro Dots

P/N 9704-44118	34-845-XXS
P/N 9704-44119	34-845-XS
P/N 9704-44120	34-845-S
P/N 9704-44121	34-845-M
P/N 9704-44122	34-845-L
P/N 9704-44123	34-845-XL



G-TEK® MAXIFLEX® ULTIMATE™



- Ultra-lightweight, knitwrist, Micro-Foam nitrile coated glove
- AirTech® technology delivers 360° breathability
- Optimized, controlled grip through our micro-cup finish
- Minimal palm thickness and thinner than most comparable gloves
- Class leading form, fit and feel, reducing hand fatigue and increased comfort
- DURAtch delivers best in class cost-to-wear through maximum durability

Black Micro-Foam Coated Palm and Finger Tips

P/N 9704-44101	34-874-XXS	P/N 9704-44104	34-874-M
P/N 9704-44102	34-874-XS	P/N 9704-44105	34-874-L
P/N 9704-44103	34-874-S	P/N 9704-44106	34-874-XL

JOURNEYMAN & JOURNEYMAN-KV



- General goatskin leather; split goatskin leather reinforced fingertips
- Thermo Plastic Rubber molded knuckle guards; reflective knuckle tape
- Nylon spandex fabric
- Internal foam padded palm
- Sandy PVC thumb crotch and thumb reinforcement
- Micro cotton thumb
- Hook and loop closure patch; easy-on, easy-off design
- Journeyman-KV is lined with Kevlar® brand fiber

Journeyman

P/N 9704-44164	120-4200-S
P/N 9704-44165	120-4200-M
P/N 9704-44166	120-4200-L
P/N 9704-44167	120-4200-XL
P/N 9704-44168	120-4200-XXL

Journeyman-KV

P/N 9704-44169	120-4100-S
P/N 9704-44170	120-4100-M
P/N 9704-44171	120-4100-L
P/N 9704-44172	120-4100-XL
P/N 9704-44173	120-4100-XXL

PERSONAL EQUIPMENT

USA: 1-877-GO ALTEC
(1-877-462-5832)

www.alteconnect.com



Altec
Supply

KLEIN TOOLS®



Committed to manufacture the highest quality hand tools with unmatched durability and comfort for over 155 years

Journeyman Gloves

Constructed with the latest high-quality materials, the new Journeyman™ Gloves provide ample comfort and functionality.



Extreme Gloves

- PORON® padding material in the palm to absorb impact and vibration
- Palm and thumb reinforced with synthetic leather for extra durability
- Rubberized fingertips for extra grip
- Wrist closure with hook and loop secures fit

P/N 9706-37109 40217 Medium
P/N 9706-37110 40218 Large
P/N 9706-37111 40219 X-Large



Utility Gloves

- Moisture wicking and breathable Trek Dry™ stretch material on top with sponge foam and tricot lining for maximum comfort
- Durable synthetic leather palm
- Reinforced thumb and finger panels add protection and durability
- Wide opening elastic cuff for easy on/off

P/N 9706-37112 40205 Medium
P/N 9706-37113 40206 Large
P/N 9706-37114 40207 X-Large

Camouflage Gloves



- Mossy Oak® Break-Up Infinity™ pattern
- Moisture wicking and breathable Trek Dry™ stretch material on top with sponge foam and tricot lining for maximum comfort
- Reinforced thumb and finger panels add protection and durability
- Single layer, seamless palm made of durable synthetic leather for improved fit and dexterity
- Soft molded rubber closure with hook and loop secures fit

P/N 9706-37115 40208 Medium
P/N 9706-37116 40209 Large
P/N 9706-37117 40210 X-Large



Cold Weather Pro Gloves

- Palm and fingers lined with Thinsulate™ C40 with fingertip designed for improved dexterity
- Water resistant nylon back lined with Thinsulate™ C100
- Durable rubberized palm provides water resistance and grip with 2mm EVA foam padding for impact protection
- 5 mm EVA foam knuckle for impact protection and comfort.
- Neoprene thumb and cuff for comfort and water resistance
- Molded rubber closure with hook and loop secures fit
- Wide opening elastic cuff for easy on/off

P/N 9706-37118 40211 Medium
P/N 9706-37119 40212 Large
P/N 9706-37120 40213 X-Large

Grip Gloves



- Armortex® rubberized grip on the fingers with reinforced synthetic leather palms and thumb for ample grip in both wet and dry conditions
- Flexible, yet impact absorbing thermo plastic rubber (TPR) protects the fingers and back of the hand
- PORON® padding material in the palm to absorb impact and vibration
- Moisture wicking and breathable Trek Dry™ stretch material on top with sponge foam and tricot lining for maximum comfort
- Neoprene cuff and soft molded rubber closure with hook and loop secures fit
- Machine washable

P/N 9706-37121 40214 Medium
P/N 9706-37122 40215 Large
P/N 9706-37123 40216 X-Large

Leather Gloves

- Genuine professional grade leather offers the finest in protection and comfort
- Flexible yet impact absorbing thermo plastic rubber (TPR) protects the fingers, back of the hand
- Reinforced palm with 2mm EVA foam padding for impact protection.
- Moisture wicking and breathable Trek Dry™ stretch material on top with sponge foam and tricot lining for maximum comfort
- Machine wash and dry
- Neoprene cuff and soft molded rubber closure with hook and loop secures fit



P/N 9706-37124 40220 Medium
P/N 9706-37125 40221 Large
P/N 9706-37126 40222 X-Large

Committed to manufacture the highest quality hand tools with unmatched durability and comfort for over 155 years

Lineman's Walk Around Gloves



- Spandex cuff for secure, comfortable fit
- 4" Leather Cuff
- Reinforced palms and fingers for durability
- Durable construction; excellent *flexibility*
- Extra padded knuckles
- Spandex material is breathable – comfortable to wear all day
- Designed by lineman for lineman – not your typical work glove
- 4" leather cuff for durability

WARNING: These gloves are NOT intended for energized electrical use

P/N 9702-66779 40080 Medium
P/N 9702-66780 40082 Large
P/N 9702-66781 40084 Extra Large
P/N 9702-66782 40086 2X-Large

Deerskin Work Gloves

- Premium deerskin, soft and form-fitting for maximum comfort
- Gunn cut with seams away from wear surfaces
- Inseam index finger
- Shirred-elastic wrist back
- Natural light-tan color

P/N 9706-40779 40020 Small
P/N 9706-40780 40021 Medium
P/N 9706-40781 40022 Large



Deerskin Work Gloves - Lined



- Premium deerskin, soft and form-fitting for maximum comfort
- Gunn cut with seams away from wear surfaces
- Inseam index finger
- Shirred-elastic wrist back
- Natural light-tan color

P/N 9702-88947 40016 Medium
P/N 9702-88952 40017 Large
P/N 9706-40782 40018 X-Large

GLOVES

Kunz Foreman's Style Gloves



- The foreman's style glove offers extreme comfort combined with high-quality workmanship
- This glove is designed for light duty wear
- Ideal for jobs needing maximum dexterity
- Manufactured by Kunz in the USA

of heavy top grain leather

- 10" overall length
- Sewn in the gunn pattern with strong nylon thread

P/N 9000-40022 390 Medium
P/N 9000-40023 390 Large
P/N 9000-40024 390 X-Large

Kunz Medium-Cuff Gloves



- "Slip-on" style glove is durable
- Leather safety cuff has a reinforcing wrist pad and offers limited arm protection
- Manufactured by Kunz in the USA
- Heavy side-split cowhide leather
- Gunn cut with seams away from wear surfaces

P/N 9000-40007 400 Medium
P/N 9000-40008 400 Large
P/N 9000-40009 400 X-Large

Premium Grain Leather Palm Gloves



- "A/B" grade cowhide
- Lined palm
- Solid white fabric back
- 2 3/4" rubberized safety cuff
- 4 1/2" rubberized gauntlet

P/N 9701-58435 500G Size 9/M
P/N 9701-58437 500G Size 10/L
P/N 9701-58440 500G Size 11/XL

Kunz Drivers Style Gloves



- Made of high-quality cowhide leather, the drivers style glove is the most popular style of work glove
- Manufactured by Kunz in the USA, these gloves outwear any standard industrial grade glove
- Economically priced

- Gunn cut and keystone thumb
- Made of cowhide leather
- Features an elastic back for better comfort

P/N 9000-40004 956 Medium
P/N 9000-40005 956 Large
P/N 9000-40006 956 X-Large

Kunz Long-Cuff Gloves



- "Gauntlet" style glove, popular for lineworkers
- Reinforced thumb strap provides extreme durability; elastic back prevents slipping
- Manufactured by Kunz in the USA
- Soft, flexible, top-grain cowhide leather
- 4.5" lined split leather cuff

- Sewn in gunn pattern with strong nylon thread
- P/N 9000-40010 148 Medium
P/N 9000-40011 148 Large
P/N 9000-40012 148 X-Large

Premium Grain Driver Gloves



- "A" grade cowhide
- Keystone thumb
- Shirred elastic back
- Rolled hemmed cuff

Premium Grain Driver Gloves:
P/N 9701-58447 602A Size 8/S
P/N 9701-58449 602A Size 9/M
P/N 9701-58450 602A Size 10/L
P/N 9701-58451 602A Size 11/XL
P/N 9701-58452 602A Size 12/XXL

THINSULATE-LINED Cold Weather Gloves:

P/N 9701-58441 602AT Size 9/M
P/N 9701-58443 602AT Size 10/L
P/N 9701-58445 602AT Size 11/XL

N-Ferno® 6990 Hand-Style Warming Packs



- Just open the pack and the all-natural ingredients in these N-Ferno® Warming Packs instantly heat up
- Activated by oxygen and will provide hours of radiant heat
- They'll fit in N-Ferno™ Winter Liner ear pockets, in boots and gloves - anywhere heat is required
- The non-toxic warming packs are disposable
- Warming Packs heat for up to eight hours; Foot Warmers, up to five hours
- All natural ingredients heat up when they contact oxygen
- Seal from oxygen in Zip-Loc bag and reuse the next day
- One size

P/N 9702-68548 16990EG Hand Warmer
P/N 9702-68551 16992EG Feet Warmer

* Gloves not Included

SALISBURY

by Honeywell

GLOVES

Salisbury Winter Utility Gloves



- Wool/fleece blend sportwool liner and 3M Thinsulate for extra insulation
- Gauntlet cuff with adjustable closure
- Waterproof, windproof, and breathable
- Non-slip saddle for gripping wet items

P/N 9700-80927	Salisbury UWG-WPGC/S	Small
P/N 9700-80928	Salisbury UWG-WPGC/M	Medium
P/N 9700-80929	Salisbury UWG-WPGC/L	Large
P/N 9700-80930	Salisbury UWG-WPGC/XL	X Large
P/N 9700-80931	Salisbury UWG-WPGC/XXL	2X Large

Salisbury Kevlar Utility Gloves



- A cut-resistant all-purpose glove
- Fully lined with 100% Kevlar fiber
- Level 4 of 5 on EN388 Cut Test Standard
- Extensive PVC reinforcement for durability
- Double stitched for extended life

P/N 9700-80945	Salisbury UWG-KLG/S	Small
P/N 9700-80948	Salisbury UWG-KLG/M	Medium
P/N 9700-80963	Salisbury UWG-KLG/L	Large
P/N 9700-80969	Salisbury UWG-KLG/XL	X Large
P/N 9700-80970	Salisbury UWG-KLG/XXL	2X Large

Salisbury Pro Utility Gloves



- The perfect utility worker glove
- Breathable stretch nylon on back of the hand
- Extended cuff with asphalt reinforcement
- Non-slip saddle for gripping wet items
- Extensive PVC reinforcement for durability

P/N 9700-80990	Salisbury UWG-HUXT/S	Small
P/N 9700-80999	Salisbury UWG-HUXT/M	Medium
P/N 9700-81004	Salisbury UWG-HUXT/L	Large
P/N 9700-81009	Salisbury UWG-HUXT/XL	X Large
P/N 9700-81010	Salisbury UWG-HUXT/XXL	2X Large

Salisbury Winter Pro Gloves



- All-purpose and abrasion resistant
- One piece back of hand with knuckle protection
- Supportive and breathable cuff
- Double stitched for extended life

P/N 9700-80932	Salisbury UWG-WPSC/S	Small
P/N 9700-80933	Salisbury UWG-WPSC/M	Medium
P/N 9700-80940	Salisbury UWG-WPSC/L	Large
P/N 9700-80941	Salisbury UWG-WPSC/XL	X Large
P/N 9700-80943	Salisbury UWG-WPSC/XXL	2X Large

GLOVE BAGS

Canvas Glove Bags



- Made of heavy duty canvas fabric
- All bags have nickel plated industrial type snaps and two ventilation eyelets in the bottom of the bag
- Available with standard or tapered sides
- Available for 14", 16", and 18" gloves
- Available with front pocket

Bags for 14" Gloves

P/N 9000-40031	(15" x 8" x 4")
P/N 9000-40032	Tapered (15" x 8" x 5.5" - 3.5")
P/N 9000-40033	Front Pocket (15" x 8" x 4")
P/N 9000-40034	Combination Sleeve, Glove (15" x 8" x 6")

Bags for 16" Gloves

P/N 9000-40035	(17" x 8" x 4")
P/N 9000-40036	Tapered (17" x 8" x 5.5" - 3.5")
P/N 9000-40037	Front Pocket (17" x 8" x 4")
P/N 9000-40038	Combination Sleeve, Glove (17" x 8" x 6")

Bags for 18" Gloves

P/N 9000-40039	(19" x 8" x 4")
P/N 9000-40040	Tapered (19" x 8" x 5.5" - 3.5")
P/N 9000-40041	Front Pocket (19" x 8" x 4")
P/N 9000-40042	Combination Sleeve, Glove (19" x 8" x 6")

Canvas Double Glove Bags



- Made of heavy duty canvas fabric
- All bags have nickel plated industrial type snaps and two ventilation eyelets in the bottom of the bag
- Stores sets of high and low voltage gloves, rubber gloves, and leather protectors
- 19" x 8" x 6"

P/N 9700-71579

Combination Sleeve and Glove Bags



- Made of heavy duty canvas fabric
- All bags have nickel plated industrial type snaps and two ventilation eyelets in the bottom of the bag
- Snap closure

P/N 9000-40034	For 14" gloves; 15" x 8" x 6"
P/N 9000-40038	For 16" gloves; 17" x 8" x 6"
P/N 9000-40042	For 18" gloves; 19" x 8" x 6"

PERSONAL EQUIPMENT

USA: 1-877-GO ALTEC
(1-877-462-5832)

www.alteconnect.com

RAINBOW



Rainbow Technology Corporation Products

Universal Spill Kits

- The sorbents you need to absorb up to 5-gallon spills. Universal kits are economical, great for everyday use. Picks up water and absorbs other non-aggressive liquids such as oil/hydrocarbons, acid, anti-freeze, cutting oil, coolants, lubricants, and water-based chemicals. Contents are packaged in a UN-certified 3- or 6.5-gallon poly pail for convenient storage. Ideal choice for fleet maintenance and large trucks. Complies with OSHA guidelines.

* Larger kit sizes, customizable kits and replacement parts available! Call 1-877-GO ALTEC (1-877-462-5832) for more information.

Universal Spill Kit ~NO Neutralizer~



P/N 9705-83981 6276 Shown Left
P/N 9705-83993 6277 Shown Right

(SMALL) up to 1 Gallon

- (1) 3 Gallon Pail w/Lid
- (5) Universal Absorbent Pad - Gray 15"x18"
- (1) Universal Absorbent Sock - Gray 3"x48"
- (1) Goggles - Chemical Splash-Resistant
- (1) Apron - Disposable Chemical-Resistant 35"x45" 6 mil
- (1 Pair) Shoe Covers - Chemical-Resistant (Size XL)
- (1 Pair) Nitrile Gloves - Chemical-Resistant 11 mil (Size 11)
- (2) Disposal Bags - 18"x30"
- (2) Cable Ties

P/N 9705-83981 6276

(MEDIUM) up to 5 Gallons

- (1) 6.5 Gallon Pail w/Lid
- (10) Universal Absorbent Pad - Gray 15"x18"
- (3) Universal Absorbent Sock - Gray 3"x48"
- (1) Goggles - Chemical Splash-Resistant
- (1) Apron - Disposable Chemical-Resistant 35"x45" 6 mil
- (1 Pair) Shoe Covers - Chemical-Resistant (Size XL)
- (2 Pair) Nitrile Gloves - Chemical-Resistant 11 mil (Size 11)
- (3) Disposal Bags - 18"x30"
- (3) Cable Ties

P/N 9703-83993 6277



Universal Spill Kit ~with Acid Neutralizer~



(SMALL) up to 1 Gallon

- (1) 6.5 Gallon Pail w/Lid
- (2) Acid Safe PLUS Neutralizer - 2 lb Shaker
- (5) Universal Absorbent Pad - Gray 15"x18"
- (1) Universal Absorbent Sock - Gray 3"x48"
- (1) Goggles - Chemical Splash-Resistant
- (1) Apron - Disposable Chemical-Resistant 35"x45" 6 mil
- (1 Pair) Shoe Covers - Chemical-Resistant (Size XL)
- (1 Pair) Nitrile Gloves - Chemical-Resistant 11 mil (Size 11)
- (3) Disposal Bags - 18"x30"
- (3) Cable Ties
- (1) Broom and Pan Set - Chemical-Resistant

P/N 9705-83999 6250

(MEDIUM) up to 5 Gallons

- (1) 6.5 Gallon Pail w/Lid
- (2) Acid Safe PLUS Neutralizer - 10 lb. Bag
- (5) Universal Absorbent Pad - Gray 15"x18"
- (2) Universal Absorbent Sock - Gray 3"x48"
- (1) Goggles - Chemical Splash-Resistant
- (1) Apron - Disposable Chemical-Resistant 35"x45" 6 mil
- (1 Pair) Shoe Covers - Chemical-Resistant (Size XL)
- (2 Pair) Nitrile Gloves - Chemical-Resistant 11 mil (Size 11)
- (5) Disposal Bags - 18"x30"
- (5) Cable Ties
- (1) Broom and Pan Set - Chemical-Resistant
- (1) Scoop

P/N 9705-84003 6251

P/N 9705-83999 6250 Shown Left
P/N 9705-84003 6251 Shown Right



WORKSITE EQUIPMENT

USA: 1-877-GO ALTEC
(1-877-462-5832)

www.alteconnect.com

Altec Supply

RAINBOW



Rainbow Technology Corporation Products

WORKSITE EQUIPMENT

**USA: 1-877-GO ALTEC
(1-877-462-5832)**

www.alteconnect.com



Telco Wasp & Ant Spray

- Exceeds the strictest wasp spray specifications ever developed, yet quickly knocks down flying and stinging insects
- Safe for use on and in utility equipment and does not crack or craze plastics used in utility and telecom equipment
- High-output spray pattern delivers a high percentage of the formula to the target from a safe distance of 12-15'

P/N 9700-81337 88500
Case of 12 cans; 20 oz. each



Hand Sanitizer - Instant

- Waterless, antibacterial hand gel with moisturizers, Aloe Vera, and Vitamin E
- Kills 99.99% of germs without water or towels
- Sanitizes within 15 seconds

P/N 9702-11567 7152
Case of 12 8 oz. bottles

Jungle Formula Insect Repellent



- Repels gnats, mosquitoes, biting flies, chiggers, ticks, flying insects, and fleas
- Effective against ticks that carry Lyme Disease, Rocky Mountain Spotted Fever, and West Nile Virus



- Contains extra-strength 23.75% DEET
- Will not harm people, the environment, or utility and telecom equipment
- Tested to ensure safety on rubber goods
- Dielectric rating of 62,000 volts

P/N 9700-81627 4501 12 cans; 6 oz. each
P/N 9702-11566 4508 4 boxes; 50 Towelettes/Box



Tick & Mosquito Repellent Designed for FR Clothing

- Non-DEET formula provides up to 6 weeks of protection against biting insects such as ticks and mosquitoes on FR clothing surfaces without reducing the safety of the FR clothing
- So effective in killing and repelling ticks and mosquitoes it is used by U.S. Military personnel in the most heavily infested conditions
- The active ingredient Permethrin not only repels, but kills the ticks and mosquitoes that come in contact with treated clothing helping to prevent the spreading of deadly diseases.

P/N 9702-11568 4507 Case of 12 cans; 6 oz. each

Knuckles Hand Cleaner Tested Safe for Rubber Goods



- Specifically formulated to dissolve and absorb dirty contaminants from hands, tools, and equipment
- Textured on one side for scrubbing embedded, tough-to-clean contaminants such as cable filling compounds, icky pic, c-cement, tar, asphalt, heavy greases, etc.; smooth side works to trap and absorb the cleaner and dirty contaminants back into the towel, leaving hands, tools, and equipment surfaces clean
- Tested safe on rubber goods

P/N 9702-11570 79315 Bucket of 80 Towelettes
P/N 9702-11573 79316 Case of 144 Individual Towelettes

Utility Sunscreen SPF 30+



- Provides all-day protection; waterproof and greaseless
- Tested, proven safe on rubber lineman's gloves per ANSI/ASTM D120, ASTM D412, ASTM D471
- Formulated for the telecommunications and utilities industries

P/N 9700-81340 4022 12 - 4 oz. bottles
P/N 9705-69567 40230 3 boxes; 50 Pouches/Box

RAINBOW



Rainbow Technology Corporation Products

WORKSITE EQUIPMENT

USA: 1-877-GO ALTEC
(1-877-462-5832)

www.alteconnect.com

Rainbow Pole Setting Foam



1 Prepare hole for pole



2 Pour Part B container into Part A container



3 Mix together



4 Pour mixture into prepared hole with pole



5 Let sit for 30 minutes; hardware is ready to be strung



- A hydrophobic, two-part polyurethane foam that expands to fill the peripheral void between a utility pole and the hole
- Displays excellent adhesion to all pole types without the use of primers, including wood, concrete, fiberglass, steel, and decorative street lighting
- Expanding foam fills all voids
- Replaces traditional methods of backfilling distribution and transmission poles during installation
- High density, high-strength foam can structurally support the pole and maintain its upright position
- Environmentally friendly; does not contain CFCs
- Sets the pole in 10-15 minutes with strengths 3-4 times that of tamped soil
- Foam expands 15 times its original volume and sets the pole in 3 minutes to create solid foundation material

Part Number	Yield
9705-68821	1 cu. ft.
9700-81317	2 cu. ft.
9700-81325	3 cu. ft.
9700-81329	5 cu. ft.
9700-81331	6 cu. ft.
9700-81333	7 cu. ft.
9700-81334	9 cu. ft.

Pole QwikSet



- Packaged in a 50 lb. pail producing 2/3rds of a cubic foot of non-expanding concrete material. Displacing water from the hole
- Specially formulated for straightening and setting power utility poles when water is present in the hole
- Can also be used to patch cracks and holes to stop water from running into concrete structures such as; manholes, vaults, concrete pipes and conduit
- Sets up in 5 to 10 minutes and hardware can be mounted within 15 minutes

P/N 9705-68817 40590 5-Gallon Pail

Duct Seal Putty

- DUCT SEAL PUTTY is an asbestos free sealer. It is gray, permanently soft, non-toxic compound which will adhere to most clean dry surfaces.
- Will not adversely affect other plastic materials or corrode metals. Safe to use on, and will not harm, polyethylene sheath cable. It also has no adverse effect to human skin.
- Used primarily by the building, telecom, and by the electrical trade to seal around service entries, manholes, electrical boxes, flashings, and service mast conduits, etc. It can be shaped by hand to any form and reused if necessary.



P/N 9705-68813 79511 Case of 10 - 5 lb. Packs
P/N 9705-68816 79526 Case of 50 - 1 lb. Packs

RAINBOW

Rainbow Technology Corporation Products

WORKSITE EQUIPMENT

USA: 1-877-GO ALTEC
(1-877-462-5832)

www.alteconnect.com

Fire Ant & Insect Killer



- Granular insecticide protects equipment and personnel from insect damage and injury
- Non-conductive and non-corrosive
- Provides long-lasting protection from ant, black widow spiders, brown recluse spiders, crickets, fire ants, fleas, millipedes, roaches, scorpions, silverfish, sowbugs, ticks, waterbugs, and soil-infesting insects

P/N 9700-89232 100 - 4 oz. single application bags
P/N 9700-89239 5 Shaker cans, 6 lbs. each

Clean & Lube



- Heavy-duty silicone provides superior penetration and lubrication for metals, plastics, and rubber while protecting against oxidation and corrosion caused by moisture and UV rays
- Effectively removes rubber bloom oxidation, carbon, light greases, dirt, and light contaminants from plastics, metals, and rubber goods
- Non-flammable silicone spray and cleaner all-in-one

P/N 9702-11555 4410 Case of 12 16 oz. cans

PowerSolv



- Also removes carbon, grease, oil, and other contaminants from almost any surface including electrical motors, contacts, switch gears, primary cable transformers, and machinery. It's compatible with all polyethylene and EPR cable insulations, semi-conducting shields, EPDM, silicone rubber, splice, and termination materials.
- This product is non-corrosive and may be used on rubber, metals, and plastic. It dries quickly and completely with NO residue. Use this versatile cleaner as a wipe on/wipe off, in parts washers or in tanks for immersion cleaning.

P/N 9705-68798 4214 Case of 12 - 1 Qt. Bottles
P/N 9705-68800 4214-1 Case of 4 - 1 Gallon Containers
P/N 9705-68802 4214-5 5 Gallon Pail
P/N 9705-68803 4214-55 55 Gallon Drum
P/N 9700-96295 42142 Case of 12 - 20 oz. Aerosol Cans
P/N 9705-68815 42147 Case of 150 Individual Packs

- Removes contaminants and anti-oxidation compounds from semi-conducting jackets and insulation on electrical cable before termination.

Cleaner & Degreaser



- Highly-concentrated citrus formula
- Ideal for general purpose cleaning on tools and equipment
- Removes cable filling compounds, grease, oil, grime, printing inks, and more
- Non-corrosive; safe for painted and non-painted surfaces

P/N 9701-69607 4305
20 oz. Aerosol Case of 12

Fast Dry Contact Cleaner



- Rainbow's most powerful cleaner
- Quickly and effectively cleans sensitive electric and electronic components
- Ideal for applications where lower flash point solvents may be used
- Flammable

P/N 9701-69618 87020
16 oz. Aerosol Case of 12



Osh Kosh Straight Shovels



- Made with hardwood handles and 10" wide high carbon steel blades
- The blade is forged in a straight pattern and heat-treated
- The shovel blade and back strap are electrically seam-welded to a front strap
- The shovel is completely straight from end to end for effective use in deep holes
- This shovel is also offered with a 6" blade
- The shovel straps and handle have footage markers to indicate hole depth
- Available with Ash or Maple handles
- Available with 6" or 10" blade

<u>Part Number</u>	<u>Osh Kosh</u>	<u>Description</u>
P/N 9000-02032	2032	7' Ash Shovel
P/N 9000-20326	2036	7' Ash Shovel w/6" blade
P/N 9000-01005	1005	7' Ash Replacement Handle
P/N 9000-02033	2033	8' Ash Shovel
P/N 9000-20336	2033-6	8' Ash Shovel w/6" blade
P/N 9000-88933	1006	8' Ash Replacement Handle
P/N 9000-02034	2034	9' Ash Shovel
P/N 9000-20346	2034-6	9' Ash Shovel w/6" blade
P/N 9000-01007	1007	9' Ash Replacement Handle
P/N 9000-02035	2035	10' Ash Shovel
P/N 9000-20356	2035-6	10' Ash Shovel w/6" blade
P/N 9000-88931	1008	10' Ash Replacement Handle
P/N 9000-02036	2036	12' Ash Shovel
P/N 9000-20366	2036-6	12' Ash Shovel w/6" blade
P/N 9000-01009	1009	12' Ash Replacement Handle

Osh Kosh Spoon Shovel Blades



- Made from the same high-carbon steel as the rest of the Oshkosh shovel line
- Available in two unique styles - Eastern and Western
- Both designs have a scoop shape for lifting mud, water and backfill from deep holes
- The shovel straps and handle have footage markers to indicate hole depth
- Western pattern designed for harder, clay-like soils
- Eastern pattern designed for lighter, sandier soils
- Available with Ash or Maple handles
- Available with 7', 8', 9', 10', or 12' handles

<u>Part Number</u>	<u>Osh Kosh</u>	<u>Description</u>
9000-02023	2023	7' Ash Spoon, Western
9000-20235	2023E	7' Ash Spoon, Eastern
9000-01005	1005	7' Ash Replacement Handle
9000-02024	2024	8' Ash Spoon, Western
9000-20245	2024E	8' Ash Spoon, Eastern
9000-88933	1006	8' Ash Replacement Handle
9000-02025	2025	9' Ash Spoon, Western
9000-20255	2025E	9' Ash Spoon, Eastern
9000-01007	1007	9' Ash Replacement Handle
9000-02026	2026	10' Ash Spoon, Western
9000-20265	2026E	10' Ash Spoon, Eastern
9000-88931	1008	10' Ash Replacement Handle
9000-02027	2027	12' Ash Spoon, Western
9000-20275	2027E	12' Ash Spoon, Eastern
9000-01009	1009	12' Ash Replacement Handle

Please contact your Altec Supply Account Manager for more information regarding quality OshKosh Products.



Osh Kosh Digging Spud with Tamper



- The digging spud is made from 1" steel pipe for easy gripping, is well-balanced and easy to use
- The 3 1/2" blade is hammer forged from high carbon steel, press-fitted and welded onto the pipe
- Hardness is controlled to maintain sharpness of edges and point through many hours of use, yet not so hard as to promote chipping in ordinary service

P/N 9000-08526	852-6	6' Digging Spud w/Tamper, 1" x 6'
P/N 9000-08528	852-8	8' Digging Spud w/Tamper, 1" x 8'
P/N 9000-00852	852-9	9' Digging Spud w/Tamper, 1" x 9'

Osh Kosh Round Tamp & Digging Bars



- These digging bars are made of high carbon steel, to resist bending deformation
- The round tamp and digging bars have a 2" chisel on one end and a malleable iron tamper on the opposite end
- Hardness is controlled to maintain sharpness of edges and point through many hours of use, yet not so hard as to promote chipping in ordinary service

P/N 9000-01071	1071	1" x 7' Tamp & Digging Bar
P/N 9000-01072	1072	1" x 8' Tamp & Digging Bar
P/N 9000-01074	1074	1 1/8" x 7' Tamp & Digging Bar
P/N 9000-01075	1075	1 1/8" x 8' Tamp & Digging Bar

Osh Kosh Crow & Digging Bars



- These digging bars are made of high carbon steel, to resist bending deformation
- The crow and digging bars have a 2" chisel on one end and are pointed on the other end
- Primarily used for splitting or separating wood, concrete or metal forms
- Hardness is controlled to maintain sharpness of edges and point through many hours of use, yet not so hard as to promote chipping in ordinary service

P/N 9000-01063	1063	1" x 6' Crow & Digging Bar
P/N 9000-01061	1061	1" x 7' Crow & Digging Bar
P/N 9000-01062	1062	1" x 8' Crow & Digging Bar
P/N 9000-01064	1064	1 1/8" x 7' Crow & Digging Bar
P/N 9000-01065	1065	1 1/8" x 8' Crow & Digging Bar
P/N 9000-01066	1066	1 1/8" x 9' Crow & Digging Bar
P/N 9000-01067	1067	1 1/8" x 10' Crow & Digging Bar

Osh Kosh Skidding Tong



- Skidding tongs are intended for pulling or skidding material and are not load rated
- They must not be used for overhead lifting
- These skidding tongs are made from round, high-carbon steel bar stock, which is hammer forged and heat treated for consistent strength
- The tong sides are flattened evenly for a larger pivot bearing surface; this allows the pivot to be shorter and ensures the hooks stay in proper alignment
- Each tong unit is heat treated and 100% hardness tested to assure high quality
- The tongs are made in either "ring only" or "swivel hook and ring" style

P/N 9000-03841	384A	Tong w/ring, 1" x 16"
P/N 9000-03842	384B	Tong w/ring, 1" x 21"
P/N 9000-00384	384	Tong w/ring, 1" x 24"
P/N 9000-00385	385	Tong w/ring, 1 1/8" x 32"
P/N 9000-00386	386	Tong w/ring, 1 1/4" x 36"

Please contact your Altec Supply Account Manager for more information regarding quality OshKosh Products.



Osh Kosh Lug Hooks



- Made exclusively for carrying poles by hand
- Handles are made of sturdy hard maple
- Hooks are made from high-carbon steel and attached to the handle with a malleable iron swivel to facilitate easy operation

P/N 9000-00295	295	Lug Hook, 2 1/2" x 4'
P/N 9000-00593	593	Replacement Handle, 2 1/2" x 4'
P/N 9000-00296	296	Lug Hook, 2 1/2" x 4'-6"
P/N 9000-00594	594	Replacement Handle, 2 1/2" x 4'-6"
P/N 9000-00297	297	Lug Hook, 2 1/2" x 5'
P/N 9000-00595	595	Replacement Handle, 2 1/2" x 5'
P/N 9000-00298	298	Lug Hook, 3" x 5'
P/N 9000-00963	963	Replacement Handle, 3" x 5'
P/N 9000-00299	299	Lug Hook, 3" x 6'
P/N 9000-00964	964	Replacement Handle, 3" x 6'

Osh-Kosh Cant Hook



- Dimensions: 2 1/4" x 4 1/2"; weighs 8 lbs.
- Features a thick hardwood handle and a high carbon steel hook which is heat treated
- Designed to prevent the hook from falling back and damaging the handle
- Leather safety cuff has a reinforcing wrist pad

P/N 9007-00200	200-A	2 1/4" x 4'6"
P/N 9702-12271	573	Replacement Handle, 2 1/4" x 4'6"
P/N 9000-01999	199	2 1/2" x 4'
P/N 9000-00575	575T	Replacement Handle, 2 1/2" x 4'
P/N 9000-00480	480	Replacement Hook, 1" x 1/2"
P/N 9000-02000	200	2 1/2" x 4'6"
P/N 9000-00576	576T	Replacement Handle, 2 1/2" x 4'6"
P/N 9000-02010	201	2 1/2" x 5'
P/N 9000-00577	577	Replacement Handle, 2 1/2" x 5'
P/N 9702-41654	206-4645	2 3/4" x 6'

Osh Kosh Peavies



- Designed and constructed for balance and easy handling
- Handles are made of hardwood and the hooks and pikes are constructed of high-carbon steel
- Unique hook stop prevents the hook from falling back and damaging the wooden handle
- Peavies are intended to have only human force applied during their use
- Adding an extension or mechanical force on the handle can result in tool damage and serious injury to the user

P/N 9000-01370	137	2 1/2" x 4'
P/N 9000-00575	575T	Replacement Handle, 2 1/2" x 4'
P/N 9000-01380	138	2 1/2" x 4' - 6"
P/N 9000-00576	576T	Replacement Handle, 2 1/2" x 4' - 6"
P/N 9000-01390	139	2 1/2" x 5'
P/N 9000-00577	577T	Replacement Handle, 2 1/2" x 5'
P/N 9000-00480	480	Replacement Hook, 1" x 1/2"

Please contact your Altec Supply Account Manager for more information regarding quality OshKosh Products.



OshKosh Tools



Osh Kosh Tamp Bars



- These tamp bars are used to flatten and smooth dirt, stone, asphalt and other materials
- The tamp bars are available in either a light or heavy weight, with a variety of handle lengths
- Curved-head tamp bars are also available
- The curved head bars are designed and built to tamp closer to the wall of the hole or close to the pole itself
- The unique curved-head design helps to prevent "knuckle busting" on the pole

- Available with 7', 8', 9', or 10' handles
- Available with a light, heavy, or curved shoe

P/N 9000-00854	854	7' Light Tamp Bar
P/N 9000-01054	1054	7' Heavy Tamp Bar
P/N 9000-36987	3698-7	7' Curved Tamp Bar
P/N 9000-02002	2002	7' Heavy Replacement Handle
P/N 9000-73698	3698-A7	7' Curved Replacement Handle

P/N 9000-00855	855	8' Light Tamp Bar
P/N 9000-01055	1055	8' Heavy Tamp Bar
P/N 9000-36988	3698-8	8' Curved Tamp Bar
P/N 9000-02003	2003	8' Heavy Replacement Handle
P/N 9000-83698	3698A8	8' Curved Replacement Handle

P/N 9000-00856	856	9' Light Tamp Bar
P/N 9000-01056	1056	9' Heavy Tamp Bar
P/N 9000-36989	3698-9	9' Curved Tamp Bar
P/N 9000-20031	2003A	9' Heavy Replacement Handle
P/N 9000-93698	3698A9	9' Curved Replacement Handle

P/N 9000-00857	857	10' Light Tamp Bar
P/N 9000-01057	1057	10' Heavy Tamp Bar
P/N 9000-36981	3698-10	10' Curved Tamp Bar
P/N 9000-20032	2003B	10' Heavy Replacement Handle
P/N 9000-13698	3698-A10	10' Curved Replacement Handle

Osh Kosh Pole Cradle



- Provides a simple method for lifting poles into position for framing
- Makes lifting poles a one-man operation
- Utilizes the simple cam principle of rocking the pole off the ground and lifting it up
- Made from aluminum
- Dimensions: 18" x 15" x 9"
- Handles poles with a diameter of up to 19"

P/N 9000-04241 4241

Osh Kosh Load Rated Lifting Tong



- Lifting tongs are signified by the yellow color and are capable of lifting up to 5000 lbs.
- All units are tested per ASTM B 30.20 D 1999
- Each unit is tagged with rated load and serial number
- Test data is supplied with each tong

Load Limit

Tool Opening:	75°	135°	180°
P/N 9000-03840	2500	2000	1500
P/N 9000-33860	5000	4000	3000

P/N 9000-03840	384L	1" x 24"
P/N 9000-33860	386L	1 1/4" x 36"

Osh Kosh Post Hole Digger (Split Handles)



- Alloy steel blades are attached by welding, making a durable joint
- Fulcrum members are made of heavily constructed, channel-shaped steel
- Produces 6" diameter holes

P/N 9000-02050	2050-8	8' Digger
P/N 9000-02058	2050A-8	8' Rep. Handles
P/N 9007-20509	2050-9	9' Digger
P/N 9000-20509	2050A-9	9' Rep. Handles
P/N 9000-02053	2050-103	Head Assembly

Osh Kosh Post Hole Digger (Solid Handles)



- Alloy steel blades are attached by welding, making a durable joint
- Fulcrum members are made of heavily constructed, channel-shaped steel
- Produces 6" diameter holes

P/N 9000-02051	2051	8' Digger
P/N 9000-20513	2051-103	Head Assembly
P/N 9000-20518	2051A-8	8' Rep. Handles



TiiGER

Utility & Pole Pulling Equipment
Created by Linemen for Linemen

WORKSITE EQUIPMENT

USA: 1-877-GO ALTEC
(1-877-462-5832)

www.alteconnect.com

The **TiiGER** Load and Deck Dolly, the Safe and Most Efficient Choice in Material Handling Equipment.

LOAD DECK AND DOLLY



SPECIFICATIONS MODEL 1030A

Height	24"
Width	32"
Length (No handle)	97"
Deck Capacity	3000 lbs.
Weight (Complete)	365 lbs.
Weight (Load Deck only)	125 lbs.
Weight (Two-Sided Dolly)	116 lbs. ea
Weight ("T" Handle)	8 lbs.
P/N 9702-38600 TiiGER 1030A	

Expand the capability of the Model 1025A poll dolly with the addition of a load deck, a simple spring latch allows for attachment in just seconds, providing a deck & dolly assembly for handling a great variety of tools and equipment.

P/N 9700-34373 TiiGER 1025A

- 180 degree steering, allows for movement forward/backward, plus sideways
- Supplied with a "T" handle assembly for easy handling
- 3,000 pound capacity
- Constructed with high yield steel

LOAD-N-GO PORTABLE REEL RACK SYSTEM



The safer, cost effective way to handle wood, plastic, or metal reels. The Load-N-Go handles multiple reels or a single reel with a maximum reel size of approximately 41" wide X 65" high. Its primary uses include: Installation of underground wires in open trenches or in conduits and overhead wires*.



SPECIFICATIONS MODEL LNG-2012

Dimensions	48" x 48.75" x 34" high
Dimensions	48" x 48.75" x 4" high (Collapsed)
Capacity	2000 pounds
P/N 9704-12702 LNG-2012	



- Fork lift pockets on all four sides, equipped with reel locking collars
- Lifting points for handling with a crane/digger truck
- Collapsible design for easy storage
- Tie points for securing in a truck or trailer
- Easy loading onto a digger or dump truck
- Fits most pick-up trucks and trailers
- 2,000 pound capacity

*Load-N-Go, is not designed for tension stringing applications.





TiiGER

Utility & Pole Pulling Equipment
Created by Linemen for Linemen

TiiGER Material Handling Equipment, ergonomically designed to help you work more efficiently.

WORKSITE EQUIPMENT

USA: 1-877-GO ALTEC
(1-877-462-5832)

www.alteconnect.com

TWO-WHEEL DOLLY



Model 1025A, with two wheel dolly, roller cradle, hold-down strap and straight handle.



The additional pole dolly feature provides an excellent platform for framing a pole. The Roller Cradle allows for 360 Degree Rotation.

SPECIFICATIONS

Height (Overall with Cradle)	27 1/4 inches
Width	32 inches
Length (No handle)	23 1/4 inches
Deck Capacity	3000 pounds
Steering	180 Degrees
Weight (Total)	157 pounds
Weight (Roller Cradle only)	41 pounds
Capacity	2,200 pounds

P/N 9700-34373 TiiGER 1025A

- 180 Degree Steering allows movement forward, backward and sideways
- Only 32" Wide
- 3,000 Lb. load deck capacity
- Low-pressure Turf Tires
- Assembled with sealed wheel bearings and bronze steering bushings

UNIVERSAL DOLLY



Designed for effective handling of pole or pad mounted transformers.

SPECIFICATIONS

Height	60 inches
Width	40 inches
Length	100 inches
Weight	210 pounds
Capacity	1,000 pounds

P/N 9703-54364 TiiGER HA0080

- Extremely stable load platform
- Accommodates pad and pole mounted transformers
- Easy transport over any terrain
- Accessories included: spreader bar, hooks, attachment bolts and straps
- Easy positioning for loading and unloading

TRANSFORMER DOLLY



The only compact pole mount transformer dolly ergonomically designed to eliminate operator arm strain

SPECIFICATIONS

Height	44 3/4 inches
Width	40 inches
Length	39 inches
Tire Size	165/165/-8
Capacity	950 pounds

P/N 9702-44692 TiiGER HA0075

- Designed for safe and easy handling
- Accommodates various size transformers
- Easy transporting in any terrain
- Vertical positioning prevents leakage
- Equipped with a third pilot wheel to allow 360° steering

Transformer Height - Standard Dolly - 36" Max
Optional Extension Attachment - 44" Max

Little Giant
Ladder Systems

CLIMB ON

SUMOSTANCE

ENGINEERED TO SAVE LIVES

- Patent-pending SumoStance is the world's only widestance extension ladder with adjustable outriggers, which triple its base width and increase side-tip stability by over 600%.
- Both SumoStance outriggers adjust 9 inches up and down to work on nearly any surface. Proper tilt angle and level indicators help ladder users set the SumoStance in the safest operating position.
- Other models and options are available (visit LittleGiantSafety.com).

	16'	20'	24'	28'	32'
Cable Hook & V-Rung	9706-37301 (15605-179)	9704-49493 (15619-008)	9703-85284 (15618-008)	9703-85332 (15609-008)	9706-37302 (15620-008)
Claw	9706-37303 (15605-195)	9703-77970 (15619-195)	9706-37304 (15618-195)	9706-37305 (15609-195)	9706-37306 (15620-195)
House Pad (with Auto-Levelers)	N/A	9706-37307 (15520-175)	9706-37308 (15524-175)	9706-37309 (15528-175)	9706-37310 (15532-175)
Weight Capacity	375 lbs.	375 lbs.	375 lbs.	375 lbs.	375 lbs.
ANSI Duty Rating	Type IAA	Type IAA	Type IAA	Type IAA	Type IAA
Heights	9' 5" - 12' 5"	11' 5" - 16' 5"	13' 5" - 20' 5"	15' 5" - 24' 5"	17' 5" - 28' 5"
Storage Height x Width x Depth	9' 5" x 1' 10" x 6.5"	11' 5" x 1' 10" x 6.5"	13' 5" x 1' 10" x 6.5"	15' 5" x 1' 10" x 6.5"	17' 5" x 1' 10" x 6.5"
Ladder Weight w/out addons	45 lbs.	50 lbs.	55 lbs.	60 lbs.	75 lbs.



LUNAR

**THE LIGHTEST
NONCONDUCTIVE
FIBERGLASS
EXTENSION LADDER**

- Features Little Giant's unique Litewave™ resin-fiberglass composite rail technology - making the Lunar a lightweight ANSI-industrial-rated nonconductive fiberglass extension ladder, and resulting in an industrial-strength ladder that weighs as much as 30% less than ordinary extension ladders.
- Rated for special duty use (Type IAA - 375 lbs. Duty Rating)
- Built-in Bubble Level to assist stability and safety
- Optional Cable Hooks and Pole Grip available

	16'	20'	24'	28'	32'
Cable Hook & V-Rung	9706-37311 (15621-179)	9706-38584 (15626-179)	9703-85340 (15627-009)	9703-85345 (15628-009)	9706-37312 (15629-009)
Claw	9706-37313 (15621-195)	9706-37314 (15626-195)	9706-37315 (15627-195)	9706-37316 (15628-195)	9706-37317 (15629-195)
House Pad (with Auto-Levelers)	9706-37318 (15621-199)	9706-37319 (15626-199)	9706-37320 (15627-199)	9706-37321 (15628-199)	9706-37322 (15629-199)
Weight Capacity	375 lbs.	375 lbs.	375 lbs.	375 lbs.	375 lbs.
ANSI Duty Rating	Type IAA	Type IAA	Type IAA	Type IAA	Type IAA
Heights	8' 6" - 13' 6"	10' 6" - 17' 6"	12' 6" - 21' 6"	14' 6" - 25' 6"	16' 6" - 29' 6"
Storage Height x Width x Depth	8' 6" x 1' 5.5" x 6.5"	10' 6" x 1' 5.5" x 6.25"	12' 6" x 1' 5.5" x 6.25"	14' 6" x 1' 5.5" x 6.25"	16' 6" x 1' 6.5" x 6.25"
Ladder Weight w/out addons	33 lbs.	38 lbs.	43 lbs.	47 lbs.	65 lbs.



CAGE™



Industry regulations require ladder users working above a certain height to tie off to a suitable anchor point before they can work with both hands. In some circumstances, these standards are often difficult or even impossible to keep, and often result in operators working in unsafe positions. Little Giant engineered the Aerial Safety Cage adjustable enclosed platform to be a versatile, safe alternative to tying off.

The cage is constructed of non-conductive, high-strength fiberglass. The Cage is fully adjustable in one-foot increments, allowing the operator to adjust the platform height to the job at hand. Each side adjusts independently, so operators can also use the Cage over uneven surfaces or stairs, where a mechanical lift or ordinary stepladder could never go. The Cage protects operators in a fully enclosed working platform, allowing them to work safely and quickly with two hands while complying with tie-off rules. With time- and energy-saving Tip & Glide™ Wheels and the wheel lift system, the Cage is quick and easy to move from job to job.

- No more tying off - complies with OSHA tie-off rules
- Fully adjustable to the job at hand - safely reach up to 20'6"
- Works on uneven surfaces, stairs, and upper floors

Standing Heights	3' - 5'	5' - 9'	8' - 14'
Cage w/ optional wheel lift system	9706-37323 (18503-240)	9706-37324 (18509-240)	9706-37325 (18515-240)
Weight Capacity	375 lbs.	375 lbs.	375 lbs.
ANSI Duty Rating	Type IAA	Type IAA	Type IAA
Heights	3' - 5'	5' - 9'	8' - 14'
Platform Standing Heights	9' - 12.5'	11' - 20'	13' - 24'
Storage Height / Width / Depth	7' 8" x 3' 9.5" x 11"	9' 8" x 3' 9.5" x 11"	12' 8" x 3' 9.5" x 11"
Cage Weight	110 lbs.	125.5 lbs.	153 lbs.

*Person 5'6" tall with 12" vertical reach.

SELECT STEP™ FIBERGLASS

THE ONLY ADJUSTABLE FIBERGLASS STEPLADDER ON THE MARKET



- Wide-flared base provides lateral stability, preventing many accidents caused by over-reaching
- Super-lightweight, super-strong fiberglass composite
- Unique configurations include A-frame, and 90-degree ladders, eliminating the need for multiple sizes and types of stepladders
- Less lifting, fewer handling and transport-related injuries to the shoulder and back
- Adapts to almost any situation, offering a safe, stable climbing solution and jobsite versatility
- Reduces fatigues and foot pain, improving speed and quality of work

	5' - 8'	6' - 10'
Weight Capacity	9703-85350 (15130-001) 375 lbs.	9703-85351 (15131-001) 375 lbs.
ANSI Duty Rating	Type IAA	Type IAA
A-Frame Heights	5' 1" - 8' 1"	6' 1" - 10' 1"
Storage Height x Width x Depth	5' 1" x 2' 5" x 9"	6' 1" x 3" x 9"
Ladder Weight	32 lbs.	40 lbs.

DARK HORSE™

WORK FASTER WITH LESS FATIGUE



- Wide-flared base provides lateral stability, preventing many accidents caused by over-reaching
- Super-lightweight (lighter than any other fiberglass articulating ladder), super-strong fiberglass composite
- Unique configurations include A-frame, extension, and 90-degree ladders, eliminating the need for multiple sizes and types of stepladders and extension ladders
- Less lifting, fewer handling and transport-related injuries to the shoulder and back
- Adapts to almost any situation, offering a safe, stable climbing solution and jobsite versatility
- Reduces fatigues and foot pain, improving speed and quality of work

	13'	17'	22'
Weight Capacity	9703-85346 (15143-001) 375 lbs.	9703-85348 (15147-001) 300 lbs.	9703-85383 (15145-001) 300 lbs.
ANSI Duty Rating	Type IAA	Type IA	Type IA
A-Frame Heights	3' 1" - 5' 1"	4' 1" - 7' 1"	5' 1" - 9' 1"
Extension Heights	7' - 11'	9' - 15'	11' - 19'
Storage Height x Width x Depth	3' 7" x 2' 5" x 10"	4' 7" x 2' 5" x 10"	5' 7" x 2' 5" x 10"
Ladder Weight	30 lbs.	39 lbs.	46 lbs.

WORKSITE EQUIPMENT

USA: 1-877-GO ALTEC
(1-877-462-5832)

www.alteconnect.com

MISCELLANEOUS WORKSITE EQUIPMENT

WORKSITE EQUIPMENT

USA: 1-877-GO ALTEC
(1-877-462-5832)

www.alteconnect.com



Sledge Hammer

- Hickory handle
- Handle length 16"
- Head weight 3 lbs.
- Head type forged medium carbon steel
- Hardened and tempered

P/N 9007-16718

Sledge Hammer



- Double face sledge hammer
- Hickory handle
- Head weight 8 lbs.
- Overall length: 36"
- Machine finish face

P/N 9007-11660

Columbus McKinnon Cant Hooks

- Handles are top quality white mountain hickory hardwood
- Duckbill hooks are drop forged with the bills ground to a fine point
- Clasps and extension toe rings are ductile iron castings
- For log sizes 8" - 24"
- Other models and sizes also available

P/N 9702-16397 06140 2 1/4" dia. x 4' long

P/N 9702-16398 06240 2 1/2" dia. x 4' long

P/N 9007-06250 06250 2 1/2" dia. x 4'5" long

P/N 9702-00091 06260 2 1/2" dia. x 5' long



Mud Bucket

- Overall length of 9'1"
- Quickly clears a hole of mud and silt
- Simply lower the scoop in the hole, using the handles to tilt the scoop and catch unwanted material; pull the scoop out by the handles, empty it topside and repeat
- Overall length of 9'1" until the hole has been cleared
- Sturdy aluminum bucket with two handles attached to a bailing scoop at four pivot points
- The components are helium-arc welded, and each point has mechanical steel bushings for top durability
- Holds up to 5 quarts of material in a single catch
- Weighs approximately 9 lbs.

P/N 9000-70210



Ground Rod Driver

- 1 1/8" x 6" shank size; 5/8" rod size
- 11/16" socket size
- Available in 5/8", 3/4", 7/8", and 1" ground rod sizes with various shank and rod size compatibilities
- A 3" deep hole is incorporated in the driving end to guide and support the ground rod

P/N 9701-00360 B32783

Manual Ground Rod Drivers



- Can handle an 8' rod while standing on the ground and drive the rod below grade without the need of additional tools
- Compact, self-contained tool; no sledge hammer needed
- Will not damage rod tip

P/N 9700-43792 A-58* 18 lbs.; 28" Long, 18" Stroke (Left Photo)

P/N 9000-00439 A-58H* 22 lbs.; 28" Long, 18" Stroke (Middle Photo)

P/N 9000-00440 A-58HW* Heavy Duty 28 lbs.; 34" Long, 24" Stroke (Right Photo)

*Models are also available for 1/2" and 3/4" rods. Call 1-877-GO ALTEC

MISCELLANEOUS WORKSITE EQUIPMENT



Extension Ladders

- Mar-resistant molded end caps, rope clamp ties rope to rung, shoe with slip-resistant pad and spur plate
- Plate and rung assembly are riveted at four points to each side rail to allow for rung replacement
- Nylon coated internal guides on bottom of fly section increase ease of operation
- Base and fly separate easily to use base section as single ladder
- Durable rail shield and shoe bracket protects rail from damage
- Pre-pierced holes for easy field installation of accessories
- External guides at top of base section securely interlock rails
- Slip-resistant Traction-Tred® D-rungs
- Rugged gravity spring locks operate smoothly
- Heavy duty pulley with rope
- Interlocking side rails
- Yellow electrically non-conductive side rails
- Load capacity: 375 lbs.
- Duty rating: Type IAA

For additional ladder options, please call
Altec Parts at 1-877-GO ALTEC

P/N	Total Length	Max Working Length
9000-99535*	16'	13'
9000-99536	20'	20'
9000-99537	24'	24'
9000-99538	28'	28'

* Note: Not equipped with rope and pulley

PoleProp®

- Makes utility pole framing and installation easier and more cost effective without the need of additional tools
- Lightweight - only weighs 33 pounds
- Strong - supports poles from 30' to 70'
- Stable - whether on even or uneven ground
- Compact - folds to 3" x 23" x 30" for easy storage
- Safe - eliminates stooping, kneeling or bending by the linemen
- Uniquely-engineered to significantly increase productivity throughout the pole framing and installation process.



P/N 9000-96196

"Pole Danny" Pole Framing Jack

- 1500 lbs. lifting capacity
- Ideal for raising poles off the ground without the necessity of a line truck
- Dual carrying handles
- Can easily lift up to a maximum of 4,000 lb. pole of any class
- Lightweight (39 lbs.) but extremely rugged
- Constructed of high strength aluminum alloy
- Features a fail safe hydraulic jack with a safety catch
- Handles poles with a diameter of up to 19"



P/N 9701-14287 Sherman-Reilly PD-40

Greenlee SUPERJACK Pipe Stands with V-Heads

- Supports full lengths of pipe, 1/2" - 8", when using pipe threading machines
- Height capacity: 27" - 50"
- 2,500 lbs. maximum capacity
- Folding stand includes carrying handle

P/N 9701-58458 Greenlee 10640 Superjack (shown)

P/N 9701-58697 Greenlee 10641 Folding Superjack



Pole Lifting Tongs

- Proof loaded to 2 times the working load and affixed with a permanent identification tag
- Shackle size: 1/2" nut and bolt
- 3/4" ring size

P/N 9007-40228 1" x 25"; 17 lbs.; 2500 lbs. capacity

P/N 9007-40558 1" x 36"; 50.5 lbs.; 5000 lbs. capacity



WORKSITE EQUIPMENT

USA: 1-877-GO ALTEC
(1-877-462-5832)

www.alteconnect.com

MISCELLANEOUS WORKSITE EQUIPMENT

EcoAbsorb

- Environmentally safe and 100% all natural, non-toxic absorbent, 100% safe to use around humans, animals, and safe for the environment
- Oil spills, chemical spills, hazmat spills, food and beverage spills and all other commercial and residential spills are no match for this light-weight super absorbent.
- Completely cleans any spill leaving no residue, stain, or odor behind
- Using ECO>ABSORB satisfies Fat, Oil and Grease Best Management Practices.
- Can absorb all paint spills, grease, gas spills, motor oil spills, automotive fluid spills, body fluid spills plus an array of other fluids and all chemicals except hydrofluoric acid
- 100% safe to use around humans, animals, and safe for the environment. This is a money saving and time-saving spill mitigation product, which cleans up any spill without hurting the environment in any way.



P/N 9704-57313 13031-00188

EQUIPMENT BAGS

Camouflage Tool Bag



- Extremely durable
- Ideal for work or personal use
- Also available in canvas or vinyl
- Constructed of 1000-denier Cordura Plus with Realtree Advantage Camouflage Pattern

P/N 9000-96150



P/N 9000-40025



P/N 9000-40028

Tool Bags

- Made of heavyweight canvas or heavyweight orange vinyl
- The bottom of these bags are made of a special rubber blend that offers protection and solid support
- Molded rubber runners on bottom of bag protect it from wear
- Webbing handles are sewn completely around the bag for greater strength

P/N 9000-40025 Canvas Standard (24" x 10" x 18")

P/N 9000-40026 Canvas; 2 Outside Pockets (24" x 10" x 18")

P/N 9000-40027 Canvas; 1 Outside Pocket (24" x 10" x 18"), 15 Inside Pockets

P/N 9000-40028 Orange Vinyl Standard (24" x 10" x 18")

P/N 9000-40029 Orange Vinyl 1 Outer Pocket (24" x 10" x 18")

P/N 9000-40046 Orange Vinyl Standard (24" x 10" x 18") with Roll-Up Flap and Shoulder Strap

Nut and Bolt Bag

- This bag, complete with hook and latch, hangs 6" from a belt; ideal for keeping nuts, bolts, and other small items handy on the job
- 9" x 8" x 3.75"

P/N 9000-04570



UTILITY STORAGE

Innovative, Practical Solutions To Haul Utility Tools And Gear



PROUDLY MADE IN THE



LINEMAN BACKPACK

**WIDE OPENING and
LARGE FRONT POCKET**

- Wide opening easily accommodates other equipment
- Large front pocket for separate storage of gaffs, rubber gloves or other equipment
- Durable, double stitched plastic bottom with drain holes
- Adjustable padded shoulder straps with adjustable chest strap
- Padded back area

P/N 9704-34710 5185ORA

Premium Orange Vinyl Equipment Bag

- 24"L x 18"H x 10"W
- Nylon-web handles extend down the side of the bag for extra support
- Hard rubber base
- Two heavy duty slide-action buckles for convenient, secure bag closure
- Convenient, Velcro fastening, water-proof flap for quick bag open and closure in the rain
- Large outside pocket with Velcro enclosure
- Comfort padded, adjustable shoulder strap
- Wide opening steel frame is securely riveted in top of bag

P/N 9702-89120 5181ORA



Premium Orange Vinyl Equipment Bag

- 24"L x 18"H x 10"W
- Nylon-web handles extend down the side of the bag for extra support
- Hard rubber base
- Two heavy duty slide-action buckles for convenient, secure bag closure
- Convenient, Velcro fastening, water-proof flap for quick bag open and closure in the rain
- Large outside pocket with Velcro enclosure
- Comfort padded, adjustable shoulder strap
- Wide opening steel frame is securely riveted in top of bag

P/N 9701-09138 5180



Ultra-Premium Black Vinyl Equipment Bag



- 24"L x 18"H x 10"W
- Hard rubber base
- Nylon-web handles extend down the side of the bag for extra support
- Convenient, Velcro fastening, water-proof flap for quick bag open and closure in the rain
- Two heavy duty slide-action buckles for convenient, secure bag closure
- Two large outside pockets with Velcro enclosure
- Comfort padded, adjustable shoulder strap
- Wide opening steel frame is securely riveted in top of bag

P/N 9702-89118 5182BLA

PLATFORM ACCESSORIES

USA: 1-877-GO ALTEC
(1-877-462-5832)

www.alteconnect.com

KLEIN TOOLS®



Committed to manufacture the highest quality hand tools with unmatched durability and comfort for over 155 years

PLATFORM EQUIPMENT TOOL STORAGE

LOAD RATED CANVAS BUCKETS

- High-density polyethylene top ring for strength, chemical resistance
- Polypropylene-rope handle reinforced with leather

5104 Series

- 100 lbs Max Load Rating.
- No. 1 canvas; 12" diameter x 17" tall
- Leather reinforced bottom.
- Inside pocket measures 8" x 8"

P/N 9706-36622 5104 Standard Features Only
P/N 9702-19891 5104S Features Swivel Snap

5109 Series

- 75 lbs Max Load Rating.
- No. 6 canvas; 12" diameter x 15" tall
- Black molded polypropylene bottom with drain holes.

P/N 9705-16139 5109 Standard Features Only
P/N 9701-11323 5109S Features Swivel Snap
P/N 9706-40790 5109P Features(1) 8"x8" Inside Pocket
P/N 9702-11919 5109PS Features (1) 8"x8" Inside Pocket and Swivel Snap



5104 Series



5109 Series

Vinyl Bucket Top

P/N 9706-40791 51TOP 12.5" Diameter x 3.5" Tall

Top Closing Bolt Bag



- Same durability of Klein 5416 series bull pin & bolt pouch
- Now with durable drawstring closing top to prevent items from falling out of the pouch at height
- Pouch body constructed of heavy duty, #4 canvas
- 10"H x 9"W x 5"D
- Drawstring 3"

P/N 9703-46650* Klein 5416TC
10" Tall x 9" Wide X 5" Deep
P/N 9706-40792* Klein 5416TCP
9" Wide x 12" Tall X 5" Deep
MINIMUM PURCHASE QUANTITY OF 50 UNITS

Tradesman Pro™ Organizer Tech Backpack



- Separate compartment keeps laptop protected from other tools
- Storage for adapters and cables
- Organizer pocket for pens, phone, cables, and more
- Hard, molded front pocket protects safety glasses
- 25 pockets for tons of tool storage
- Orange interior to find tools faster
- Shoulder straps and handle for easy carrying
- Tough, durable molded bottom protects from the elements.

P/N 9706-40793 55456BPL
18.25" Tall x 14" Wide x 7" Deep

PLATFORM ACCESSORIES

USA: 1-877-GO ALTEC
(1-877-462-5832)

www.alteconnect.com

PLATFORM EQUIPMENT TOOL STORAGE

Orange Oval Hard Body Bucket



- Kickstand for stability, proper orientation
- 15 interior pockets
- Orange, non-conductive plastic exterior maintains bucket shape
- Molded polypropylene bottom with drain holes

P/N 9702-90208 5144BHB

Hard Body Oval Bucket



- Includes leather skinning knife sheath and 14 other interior pockets
- Orange, non-conductive plastic exterior maintains bucket shape
- Fabric constructed of rugged denier polyester to resist wear and tear on the jobsite
- Black molded polypropylene bottom with drain holes
- Hooks sold separately

P/N 9703-20676 5144HBS

Hard Body Oval Bucket with 15 Interior Pockets & Handles



- 14"L x 7"W x 10"H
- Features 15 inside pockets and handles
- Orange, non-conductive plastic exterior maintains bucket shape
- Black molded polypropylene bottom
- Hooks sold separately

P/N 9702-89121 5144BHBB

Black Hard Body Tote Bucket



- 14"L x 7"W x 10"H
- Features 15 inside pockets, 14 outside pockets and web handle
- Constructed of rugged denier polyester to resist wear and tear on the jobsite
- Black molded polypropylene bottom with drain holes

P/N 9702-89122 5144BHB14OS

AERIAL APRONS

Klein Vinyl Tool Apron



- 24"L x 23"H
- Includes: ten hand tool pockets, two pouches, hammer loop and two vinyl drill bit pockets with plastic tubes
- Hooks sold separately

P/N 9702-89116 51829

Klein Aerial Apron with Magnet

- 24"L x 23"H
- Sewn-in magnet design won't catch on gloves
- Includes: ten hand tool pockets, two pouches, hammer loop and two vinyl drill bit pockets with plastic tubes
- Two pouches reinforced with heavy duty rivets

P/N 9703-27311 51829M

THE PELICAN 0450 MOBILE TOOL CHEST



The U.S. Army tasked Pelican with building a mobile tool chest to house tools for its maintenance engineers. Rapid deployment to harsh environments is common; arriving with your tools intact and fully functional is mission critical. Over a two year period of intensive design, research and testing, Pelican Products built the world's toughest mobile tool chest for use by the U.S. Armed Services. Over 70 tests were required, including water submersion, extreme temperature tests and drop tests from five feet fully loaded. The 0450 passed all of them. The 0450 Mobile Tool Chest: now ready for civilian use.

- Heavy duty buttress hinges; Stainless steel hinge pins provide extra protection from corrosion. Raised ribs are designed to stop the lid at 180 degrees when opened to serve as a work space, supporting up to 50 lbs.
- Auto Pressure EQ Valves - The 0450 has two built-in Automatic Pressure Equalization Valves: one for the top lid and the second for the main compartment. They make opening the case easier after altitude changes by balancing the interior pressure with the ambient pressure.
- Two Way Handles – The 0450 case can be lifted from the tool chest position or the transport position

- Stable, Wide Rack Mobility - 2" polyurethane wheels offer optimum load distribution over soft terrain
- Removable Drawers
- Hybrid Double Throw Metal Butterfly Compression Latches
- Graduated Deflector Ribs - protect the hinges and latches from shipping damage
- Secure Stack Design - "Block-In-Pocket" design locks the cases together to prevent lateral movement
- Field-Replaceable Wheels

P/N 9703-33316 0450

Need to keep track of your tools? Foam tool organizers will make your life easier. Color contrast design tells you in a quick glance if any tools are missing. Eliminate FOD (Foreign Object Damage) caused by tools left in aircraft engines or other equipment. Available as single or multi-layer foam set with compartments. Please call 1-877-GO ALTEC for additional information.

Backed By Pelican's Legendary Lifetime Guarantee Of Excellence.



HASTINGS BUCKET ACCESSORIES



Tool Organizer Board



- One piece design fits both buckets with and without liners
- Special designed bracket enables the tool boards to be easily installed and removed without tools
- Each board has a four pocket leather tool pouch, leather knife pouch, nylon loops, and hammer loop
- Utility bag is made from heavy duty cordura
- A wide leather loop is riveted on the

top of bag for easy access with rubber gloves

- Also available with lights above the cordura bag and lights along the entire bottom of board
Ideal for night time and low light conditions
Battery and switch operated. 2 AA batteries included

P/N 704-20648 05-829

Heavy Tool Tray Outside Mount



- Compact
- Lightweight
- Outside mount
- Ideal for connectors, bolts, and nuts
- Fits buckets with and without liners

P/N 7054-00094 05-951

Heavy Duty Fiberglass Step

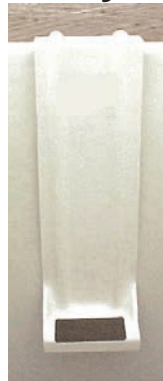

- Heavy duty fiberglass step makes it easier to get in and out of the platform
- Stepping surface has an anti-skid material to prevent possible foot slippage
- Tough durable, attractive, white plastic finish is easy to clean and maintain
- Dimensions: 26" x 8 1/2" x 8"

P/N 704-20302 05-961 For use with liner

P/N 704-20091 05-960 For use without liner

Heavy Reinforced Canvas Tool Buckets

Workers will find dozens of uses for these rugged round and oval canvas tool buckets. These canvas buckets are made from US grade #4 canvas with brass grommets. A solid non-conductive PVC ring maintains bucket shape. Round tool buckets with polypropylene rope are offered with a brass swivel snap.

Buckets with Rope, Brass Swivel Snap



Round Buckets:

P/N 9000-50304 8" x 12" (shown far left)

P/N 9000-50320 12" x 15" (shown far left)

P/N 9000-50340 10.5" x 12"; 4 Outside Pockets

Oval Buckets:

P/N 9000-50506 14" x 7" x 9"; 6 inside pockets

P/N 9000-51103 14" x 7" x 9"; 15 inside pockets

Oval Tool Buckets



- 14" x 7" x 9"
- 5 inside pockets

P/N 9000-50501



- 14" x 7" x 9"
- 16 inside pockets
- 13 outside pockets

P/N 9000-51311



- 14" x 7" x 9"
- 14 inside pockets
- Web handles

P/N 9000-50511



- 14" x 7" x 9"
- 15 inside pockets

P/N 9000-50516

Rigid Vinyl Tool Bucket (Web Handles)



- 14" x 7" x 9" oval tool bucket
- 13 inside pockets
- 13 outside pockets
- Molded rubber runners on bottom
- Web handles

P/N 9000-65703



Rigid Vinyl Tool Bucket (Brass Grommets)

- 14" x 7" x 9" oval tool bucket
- 13 inside pockets
- Brass grommets for use with hooks to attach bucket to platform
- Molded rubber runners on bottom

P/N 9700-98047

Aerial Tool Bucket

- 15" x 7" x 9" oval tool bucket with rope and brass swivel snap
- 15 outside pockets; 26 inside pockets
- Made from US grade #4 canvas with brass grommets

P/N 9700-79999



Mini Canvas Tool Buckets

- Mini tool bucket for connectors, nuts, washers and other small items
- Durable composite plastic rope handle
- Approximately 6" Tall x 4.75" Diameter

P/N 7019-93015 Canvas
P/N 9700-89243 Black



USA: 1-877-GO ALTEC
(1-877-462-5832)

www.alteconnect.com

Blackwrap Oval Tool Bucket



- 14" x 7" x 9" oval tool bucket
- 13 outside pockets
- Nylon webbing handles
- Molded rubber runners on bottom
- Heavy-duty canvas bonded with durable plastic

P/N 9700-79998

Blackwrap Aerial Tool Bucket



- Features grommet flap
- 8" x 16"
- Designed for hydraulic tools
- Durable, heavy duty design
- Brass grommets for use with hooks to attach bucket to platform

P/N 9000-00535 35-326

Blackwrap Oval Aerial Tool Bucket



- 14" x 7" x 9" oval tool bucket
- 14 inside pockets
- With BAT
- Molded rubber runners on bottom
- Heavy-duty canvas bonded with durable plastic

P/N 9702-38939 45-123

Blackwrap Oval Aerial Bucket



- 14" x 7" x 9"
- 14 inside pockets
- Made of materials bonding heavy-duty canvas with durable plastic
- Flexible and lightweight
- Non-conductive solid PVC top ring, two brass grommets to reinforce the hanger holes, and a unitized base

P/N 9000-45120

Rigid Vinyl Tool Bucket - Round

- 14 1/2" tall x 11 3/4" diameter round tool bucket
- Features brass grommets and rope with a brass swivel snap
- Molded rubber runners on bottom

P/N 9700-98046



Heavy Duty Canvas Bag



- Heavy duty canvas construction
- 8 pouches with elastic tops to retain materials
- Oversized openings for easy entry with gloves
- Designed to fit inside the 4" deep door on the basket
- 17" long, 4" wide, 28" deep

P/N 9910-01204

Fuse Holder Bag



- Marine finish contains a special additive that gives 2-3 times greater water repellancy and mildew resistance than regular finish canvas
- Includes flap for added protection

P/N 9700-82768

Vinyl Polyester Tool Roll



- This tool roll offers a convenient way to carry dozens of tools in four different pockets
- White vinyl poly shell is water repellent, strong and lightweight
- Each pocket measures 5" x 12" x 2.5"
- Tool roll dimensions: 28" x 14"

P/N 9000-11700

ALTEC SUPPLY Heavy Plastic-Reinforced Canvas Bag



- Reinforced canvas tool bag features five compartments
- Designed to hold tools related to compression projects
- Will also hold cable and bolt cutters and other hydraulic tools
- Plastic reinforced canvas construction
- Dimensions: 16" x 9" x 20"

P/N 9000-59022

ALTEC SUPPLY Heavy Reinforced Canvas Bag



- Designed for stashing left-over wire scraps and other work site throwaways
- The heavy reinforced-canvas bag can hold up to one full bushel, yet fold flat to fit almost anywhere
- The two riveted side straps and carrying handles let you hang the bag up and secure it vertically as well

P/N 9000-06265

ALTEC SUPPLY Line Hose Bag



- Protects hose and guards with this line hose bag
- May be used for hoisting materials up and down poles

- P/N 9000-27155 8" x 48" with snap
- P/N 9000-27150 8" x 48" without snap
- P/N 9700-80002 8" x 66" with snap
- P/N 9700-80001 8" x 66" without snap
- P/N 9000-27555 12" x 48" with snap
- P/N 9000-27550 12" x 48" without snap
- P/N 9700-80007 12" x 66" with snap
- P/N 9700-80003 12" x 66" without snap

PLATFORM SAFETY HOOKS

ALTEC SUPPLY Large Safety Hook



- Holds accessories on both the inside and outside of the platform
- Tough nylon provides strength and excellent cold resistance
- Virtually indestructible if used in normal conditions
- 11" x 5.75" (7" including small hook)

P/N 9701-85305 Black Hook (Sold Individually)

Large Safety Hook

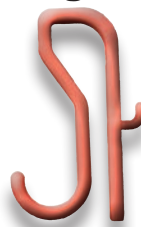

- Holds accessories on both the inside and outside of the platform
- Tough nylon provides strength and excellent cold resistance
- Virtually indestructible if used in normal conditions
- 11" x 5.75" (7" including small hook)

P/N 9701-85305 (Sold Individually)

Aerial "S" Hooks



- Fits most platforms with liners
- Molded from a mixture of plastics and nylon that give them high breaking strength and excellent cold resistance
- Holds platform accessories on both the inside and outside of the platform

- Virtually indestructible if used in normal conditions
- Stretches horizontally without breaking at 1,000 lbs.
- Retain physical properties up to 200° F and as low as -40° F

P/N 9000-01006 (Sold by the Pair)

Aerial "S" Hooks



- Holds accessories on both the inside and outside of the platform
- Tough nylon provides strength and excellent cold resistance
- Virtually indestructible if used in normal conditions

P/N 704-20456 (Sold by the Pair)

When tools are stored in these polyethylene tool trays, work is easier and more efficient. Made from high-density polyethylene, these trays are impervious to hydraulic oil, motor oil, and a broad range of chemicals. These trays are also cold resistant and UV protected. The trays have been designed to fit most platforms with or without a liner. Several sizes and shapes are available.

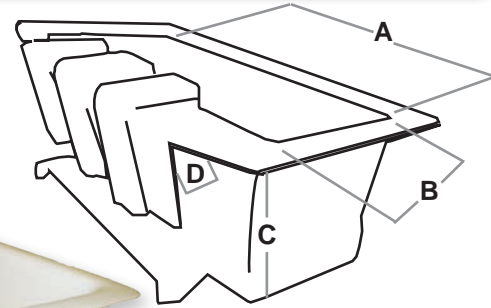

ALTEC SUPPLY Rectangular Tool Tray with Optional Pocket Pouch



- Dimensions: 18.5" (a) x 7.5" (b) x 8.25" (c) x 2 3/4" (d)
- Made from high-density polyethylene
- Cold-resistant and UV protected
- Designed to fit most platforms with or without a liner

P/N 9703-21837 Without Pockets, Outside Mount
 P/N 9703-21843 7 Pocket Pouch, Outside Mount
 P/N 9703-21844 9 Pocket Pouch, Outside Mount
 P/N 9703-53135 Magnetic Strip, Outside Mount

ALTEC SUPPLY Double Tool Tray with Outside Mount

- Dimensions: 20" (a) x 14" (b) x 8" (c) x 2 1/2" (d)
- Double tool tray with outside mount

P/N 9703-47486



ALTEC SUPPLY Deep Tool Tray with Outside Mount

- Dimensions: 15" (a) x 7" (b) x 17" (c) x 2 1/2" (d)
- Deep tool tray with outside mount

P/N 9703-47487



ALTEC SUPPLY Splicer Tool Tray with Outside Mount

- 19" long, 8" wide, 8" deep
- Designed for aerial life buckets
- Use with all types of rotating splicer baskets

P/N 9703-47488



BUCKET-MOUNTED PLATFORM TOOL TRAYS

When tools are stored in these polyethylene tool trays, work is easier and more efficient. Made from high-density polyethylene, these trays are impervious to hydraulic oil, motor oil, and a broad range of chemicals. These trays are also cold resistant and UV protected. The trays have been designed to fit most platforms with or without a liner. Several sizes and shapes are available.

Semi-Oval Tool Tray

- Dimensions 18" x 12" x 10"
- Adjustable tool straps
- Weather resistant
- Safe and convenient storage for tools and equipment
- Includes attached cover and ABH hooks

P/N 9701-34802

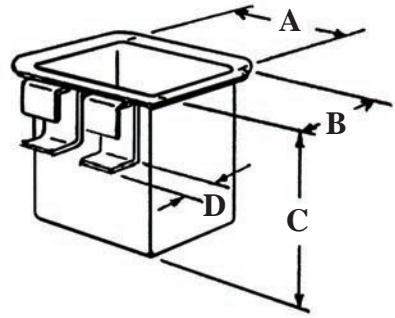

Soft Cover for Tool Trays



- Soft cover for tool trays
- P/N 9000-41110 and
- P/N 9000-41112
- P/N 9000-68710

Platform-Mounted Tool Tray with Lid

- Dimensions: 16.5" (a) x 9" (b) x 9" (c) x 2.5" (d)
- Platform mounted tray with lid

P/N 9000-41400



Tall Platform Tool Tray

- Dimensions: 7.5" (a) x 7.5" (b) x 14" (c) x 2.5" (d)
- Platform tray mounted outside
- Great for small hardware items

P/N 9000-41510



Platform Tool Tray

- Dimensions: 7.5" (a) x 4" (b) x 6" (c) x 2.5" (d)
- Platform tray mounted outside
- Great for small hardware items

P/N 9000-41500

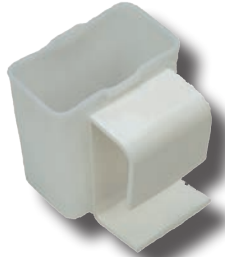

TOOL SPECIFIC CARRYING CASES & HOLDERS

ALTEC SUPPLY In-Line Crimping Tool Holders/Cases



P/N 9000-96164 shown left
P/N 9000-96165 shown middle
P/N 9000-96185 shown right

- Molded carrying case is designed to hold the Greenlee EK425 battery-powered crimping tool
- Fabricated out of vinyl, this pouch is a durable and convenient method of storage

- P/N 9000-96164 Vinyl Pouch for EK 425
- P/N 9000-96185 Vinyl Pouch for EK 425 with handle and belt strap
- P/N 9000-96165 Vinyl Pouch for EK 425 with handle, belt strap, and protective cover

ALTEC SUPPLY Platform-Mounted Chainsaw Scabbard



- This chain saw scabbard provides a safe and convenient storage place for either a gasoline or hydraulic powered chain saw
- 34.5" (a) x 16.5" (b) x 6" (c)

P/N 9703-35053 Heavy Duty Plastic

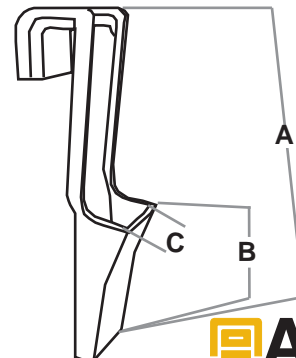

PLATFORM ACCESSORIES

USA: 1-877-GO ALTEC
(1-877-462-5832)

www.alteconnect.com



TOOL SPECIFIC CARRYING CASES & HOLDERS

Jameson Impact Tool Holder



- Adjustable clamp bracket allows holder to fit any size platform
- 10" x 6.5" x 8.75" tool holder
- Thermo-vacuum formed plastic
- A perfect fit for any impact wrench

P/N 9700-92607 Tool Holster
P/N 9700-92610 Holster with Scabbard

Hydraulic Impact Wrench/Drill Holster



- Attaches to the lip of any bucket, with or without a liner
- Can be mounted either inside or outside and used right or left handed
- Includes Velcro® hold down strap to keep wrench in place

P/N 8130-00204 05-832 Holster only
P/N 0704-20301 05-831 Holster with Scabbard

Impact Wrench Holder



- Specifically designed to stand up to weather and sunlight
- Made of a polymer material with excellent dielectric, cold weather and UV properties

P/N 9000-11200 Shallow Outside Mount
P/N 9000-11201 Shallow Inside Mount
P/N 9000-11203 Outside Mount with Locking Clips

Long Reach Chain Saw Holder



- Stores any standard hydraulic "stick saw"
- Keeps tool out of the platform when working around electrical lines
- Stores tools while vehicle is in transit
- ABS plastic withstands weather conditions and will not dull tool blades

P/N 8095-00204 Greenlee Style

Boom Mounted Hot Stick Holder



- Holds four hot sticks 1 1/4" - 2" diameter
- Ratchet load binders attach to square, rectangular, round and oval booms

P/N 7054-00287

Boom Mounted Circular Saw Holder



- Provides a safe and out of bucket storage location for all standard hydraulic circular saws
- Made of high impact plastic, the holder unit can be strapped to square or round booms and is adjustable to any convenient position

P/N 8780-10489

Hydraulic Pruner Holder



- Made from high impact plastic
- Stores any standard hydraulic pruner
- Mounts on both round and square booms

P/N 8130-00428

Chain Saw Scabbards

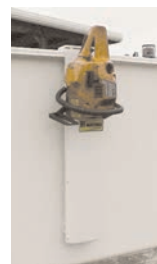

- These chain saw scabbards provide a safe and convenient storage place for either a gasoline or hydraulic powered chain saw

P/N 8130-00205 Fiberglass

Replacement Handle Holder



- Replacement handle holder for the hydraulic boom mounted tool holders
- Rubberized liner prevents the tool handle from sliding out of the upper holder box
- Fits both square and round booms

P/N 9000-24041

TOOL SPECIFIC CARRYING CASES & HOLDERS

Splicer's Box



- Designed to be used by splicer in a vault or any location where splice work is required
- Easy access to the interior of the bucket where tools and assorted supplies may be kept
- Features a 3" polymer molded bottom that keeps water out of the box
- Heavy duty polyethylene and covered in 1000 denier nylon

P/N 9701-34641

Hot Stick Hanging Rail & Tool Holder



- Rugged polyethylene and FRP construction for reliable, field-proven service
- Promotes rapid access to storage and retrieval of hot sticks, cutters, and other tools
- Carries multiple tools on rigid 3/4" diameter fiberglass rod

P/N 9700-71119 Outside Mount

P/N 9700-71120 Inside Mount

Streamlight Litebox Holder



- Designed to conveniently hold the Streamlight Litebox onto the platform
- Made of a polymer material with excellent dielectric, cold weather, and UV properties
- Mounts on the outside of the platform

P/N 7052-01144 For Liteboxes without D-rings on the handle

P/N 7052-01231 For Liteboxes with D-rings on the handle

P/N 9000-82815 For Liteboxes with D-rings, locking tabs

In-Line Crimping Tool Holder



- Fully conductive wrap-around housing offers maximum protection
- Constructed of high quality polyethylene plastic for durability and long service life
- Contains an ultra-violet inhibitor and is impervious to a broad range of chemicals
- Features a double bracket design to keep tool safely secured

P/N 9000-00568 219038

Burndy Patriot 600 & 750 Holder



- Specifically designed to hold the Burndy Patriot 600 and 750 battery-powered crimping tools
- Made of rugged high-density polyethylene, this holder is extremely durable
- Offers a maximum protection, through fully non-conductive wrap-around housing

P/N 9000-11920

In-Line Crimping Tool Holder



- Specifically designed to hold the Greenlee EK425 battery-powered crimping tool
- Made of rugged high-density polyethylene, this holder is extremely durable

P/N 9000-11910

Greenlee EK425 Pouch



- Fabricated out of durable vinyl
- Combine with "S" hooks to attach bag to the inside/outside of a platform (not included)
- Velcro® closures keep the tool clean
- Crimping jaws do not need to be removed when storing the tool

P/N 9000-11001 Greenlee CP1

PLATFORM ACCESSORIES

USA: 1-877-GO ALTEC
(1-877-462-5832)

www.alteconnect.com

TOOL ORGANIZER BOARDS

TOOL ORGANIZER BOARDS

- Save precious space in the platform and still keep tools within reach
- Made of co-extruded ABS, the tray is light and durable with superior cold weather characteristics
- Fits all platforms 18" x 20"



P/N 9000-11500



P/N 9000-11540
with Polyboard and Brackets



P/N 9000-11510



P/N 9000-11530



P/N 9000-11550



P/N 9000-11520



P/N 9000-11515

TOOL ORGANIZER BOARDS



P/N 9000-72401
Basic Model



P/N 9000-72400
with Vinyl Apron



P/N 9000-72405
with Tool Holders

- These tool boards not only help eliminate back strain, but also help keep tools organized
- These trays were designed to hang from the top lip of any platform and offer an ergonomic support
- Linemen are able to lean up against the support and brace themselves while working in the platform for long periods of time
- These tool organizers help eliminate the need for toe space in the platform

ALTEC SUPPLY Tool Apron



- 16 pocket vinyl apron
- Can be used in two-man buckets
- Large reinforced pockets a wide variety of tools including ratchet cutters, crimpers, and bolt cutters
- 2 plastic reinforced bit holders
- Tape sling, Hammer loop
- 28 1/2" x 26 1/2"
- The leather around the top edge protects fabric from

abrasion caused by frequent use of tools
P/N 9000-01829

ALTEC SUPPLY Tool Apron



- 24" x 24" with 18 pockets
- Leather knife sheath and snap, (8) tool holders, (3) socket holders, (2) tool pouches, (2) plastic reinforced bit holders, and (1) hammer loop
- P/N 9703-53123 features a magnetic strip

P/N 9000-50940

ALTEC SUPPLY Canvas Aerial Apron



- Made of durable natural canvas
- 4 tool pockets
- Hammer loop
- Large tool pouch
- 21" x 11"
- Ideal for use when

working with a smaller number of tools

- Snap from which worker can hang a knife

P/N 9000-50910

ALTEC SUPPLY Canvas Aerial Apron



- 9 pocket canvas aerial apron
- Ideal when a sizable complement of tools and other items are necessary for a job
- Durable natural canvas
- 7 tool pockets
- Bit holder
- Large pouch providing ample storage for tools
- Snap from which a knife can be hung
- 20" x 18"

P/N 9000-50925

ALTEC SUPPLY Tool Apron



- 24" x 30" 16 pocket vinyl aerial apron
- Features large reinforced pockets which allow workers to carry their tools with them while working
- Features: (5) socket holders, (4) tool pockets, (3) nut and bolt holders, (2) plastic-reinforced bit holders, (1) Hammer loop (1) Plastic-reinforced tool pouch, (1) Plastic-reinforced cable (1) Bolt cutter pocket

P/N 9000-50945 Yellow Tool Apron

P/N 9702-42311 Black Tool Apron

ALTEC SUPPLY Canvas Aerial Apron



- Linemen can use this two pocket canvas aerial apron for larger items that won't typically fit in other aprons
- Heavyweight canvas with nylon thread that won't rot.
- Dimensions: 18" L x 4" W x 10" H
- Dimensions of pockets: 6" x 8"

P/N 9000-01825

ALTEC SUPPLY Vinyl Tool Holder



- Features 6 reinforced pockets for easy storage of various drill bits
- The drill bit holder can be hung from any platform using two s-hooks (P/N 9000-01006)
- Vinyl covered weight stabilizer
- 12" x 22"

P/N 9000-42766

ALTEC SUPPLY Vinyl Crimper Tool Holder



- Features one pocket for a crimper tool and a second pocket for a bolt cutter

P/N 9000-59002

USA: 1-877-GO ALTEC
(1-877-462-5832)

www.atecconnect.com

ERGONOMIC LINERS & SCUFF PADS

ALTEC SUPPLY Standard Scuff Pads



P/N 9701-35684
Scuff Pad for 2 Man Liner



P/N 9701-35686
Scuff Pad for 1 1/2 Man Liner



P/N 9701-35685
Scuff Pad for 2 Man Liner

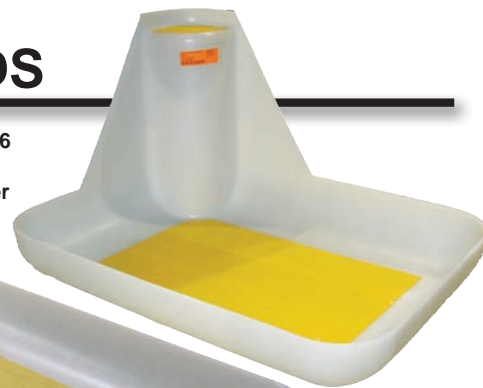

P/N 9701-34986
Scuff Pad for
1 1/2 Man Liner

Scuff Pad with Step	Scuff Pad without Step	Size	Specs	Fits Liners
8702-61354	704-20074	1 Man	24x24x42	704-20003
9701-34986	9701-35686	1 1/2 Man	23x41x29	704-20718
9701-34986	9701-35686	1 1/2 Man	24x30x41	704-20652
9701-34986	9701-35686	1 1/2 Man	28x22x41	704-20110
9701-35684	9701-35685	2 Man	46x22x41	704-20675
9701-35684	9701-35685	2 Man	46x22x41	704-20053
9701-35684	9701-35685	2 Man	20x46x41	9701-74801

- This liner-protecting fiberglass scuff pad has a rugged step built directly into it
- The surface is covered with non-skid material to eliminate slipping
- Extra sturdy construction ensures a long working life

Ergonomic Liner Pads

- Offer an excellent non-slip cushioning pad in a variety of sizes for linemen
- Help alleviate fatigue in worker's back, legs and feet
- Ergonomic liner pads also offer added safety
- Closed-cell foam base covered by non-slip polyurethane finish
- Fits platforms with or without liners
- Easily washable

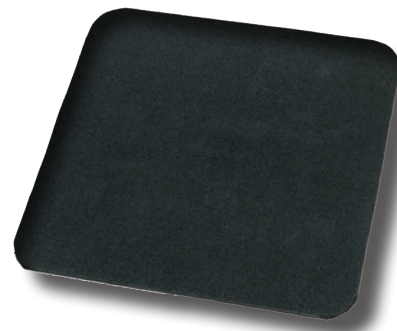

For Platforms without a Platform Liner Only:

P/N 9704-32147 For 24" x 24" Platform; 20" Long x 20" Wide x 1.13" Thick; With Foam Insulation

P/N 0704-20884 For 24" x 24" Platform; Fits most platforms; 22" x 22"*

P/N 7017-00150 For 20" x 30" Platform; 26" Long x 20" Wide x 1.13" Thick; With Foam Insulation

P/N 8130-01010 For 24" x 48" Platform; 44" Long x 20" Wide x 1.13" Thick; With Foam Insulation

*Dimensions for bottom of platform

For Platforms with a Platform Liner Only:

P/N 9000-31210 For 24" x 24" Platform; 18" Long x 18" Wide x 1.13" Thick; With Foam Insulation

P/N 9000-31200 For 24" x 30" Platform; 24" Long x 18" Wide x 1.13" Thick; With Foam Insulation

P/N 9000-31230 For 24" x 48" Platform; 24" Long x 48" Wide x 1.13" Thick; With Foam Insulation

P/N 9000-99319 For AP45 Platform; 27.5" x 27.5"

P/N 9000-31270 For Splicer Platform, One Size Accommodates All

For Older Platforms that may require slightly larger Liner Pads than above:

P/N 9704-90327 Exact Dimensions of 18" x 18"

P/N 9704-91078 Exact Dimensions of 18" x 24"

P/N 9704-90948 Exact Dimensions of 42" x 18"

Workmaster Industrial Mats



- Durable 3/4" heavy duty mat is made for industrial and commercial applications
- Drain holes and knob back construction make drainage easy
- High quality rubber compound with an open circular surface
- General purpose black color with standard edge; no bevel
- Available in sizes 24" x 36" and 36" x 60"

Altec P/N	Durable P/N	Description
P/N 7019-93009	424C0000	19.5" x 19.5"
P/N 9703-04563	427S2448BK	24" x 48"

Aerial Bucket Mount Tool Holders Keep Tools Off Bucket Floor

Jameson's heavy duty bucket mount tool holders offer safe, convenient storage for bucket truck tools. Water repellent and UV resistant, they are designed to withstand extreme weather conditions. Adjustable clamp bracket fits any size bucket.



Impact Tool Holder



Tool Tray



Tool Board

Boom Mount Tool Holders

Take the tools out of the bucket and mount them on the boom for safe, convenient access. Made from high impact plastic, Jameson's boom-mount tool holders can be strapped to round or square booms.



Long Reach Chainsaw Holder



Circular Saw Holder

Impact Tool Holder

- One-piece construction with adjustable clamp bracket
- Widest model available, Jameson's Impact Tool
- Holder accommodates most wrenches and drills

Impact Tool Holder with Scabbard

- Scabbard has two spare drill bit holders

Double Pocket Tool Holder

- New longer back accommodates a variety of tools
- Inner pocket measures 6.5 x 2.75 x 19
- Outer pocket measures 5.5 x 2.75 x 16

Tool Tray

- Removable dividers and fixed bucket mount
- 23" X 14" X 8"

Tool Board with Attachments

- Leather attachments to organize tools or hardware
- Fixed bucket mount
- 22.5" X 18"



Impact Tool Holder With Scabbard



Double Pocket Tool Holder

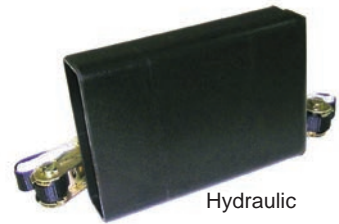

Hydraulic Pruner Holder

Altec P/N	Jameson Part	Description
9700-92607	24-12A	Impact Tool Holder
9700-92610	24-12AH	Impact Tool Holder w/Scabbard
9000-02415	24-15D	Double-Pocket Tool Holder
9700-97916	24-17	Tool Tray
9701-84534	24-25	Tool Board with Attachments
8780-10489	24-02	Circular Saw Holder with Locking Straps & Handle
8130-00428	24-04	Hydraulic Pruner Holder with Locking Straps & Handle
9817-02798	24-03	Long Reach Chainsaw Holder with Locking Straps & Handle Fits Stanley Style
8095-00204	24-03F	Long Reach Chainsaw Holder with Locking Straps & Handle Fits Greenlee Style

MISCELLANEOUS PLATFORM EQUIPMENT

Interior Step



- An ideal way to make exiting and entering a platform easy and safe
- Step fits in the corner of all standard platform forms
- Made of impact-resistant lexan
- Dielectrically safe
- Dimensions: 27 1/2" x 13 1/2" x 3/8"

P/N 9000-11100

Heavy Duty Fiberglass Step

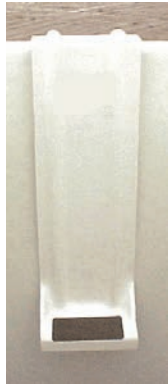

- Heavy duty fiberglass step makes it easier to get in and out of the platform
- Stepping surface has an anti-skid material to prevent possible foot slippage
- Tough durable, attractive, white plastic finish is easy to clean and maintain
- Dimensions: 26" x 8 1/2" x 8"

P/N 704-20302 For use with liner
P/N 704-20091 For use without liner

Heavy Duty Fiberglass Step - Inside Mount



- Step supports 300-400 lbs.
- Designed to fit on the inside, over the lip of the bucket
- Removable step is covered in durable, attractive, white plastic finish
- Features the black sure-step grit to prevent slipping
- 7.5" wide, 24.25" total length, 1/4" thick, 5.75" length of lip on back side

P/N 9000-06090

Rectangular Fiberglass Step



- Ergonomically designed
- Designed to fit on Altec platforms
- P/N 660-60011 anti-skid surfacing material may be added to the stepping surface to prevent possible foot slippage
- Stepping surface measures 1' x 4"
- Overall mounting surface is 3 1/2'

P/N 704-00101 Rectangular Fiberglass Step
P/N 660-60011 Anti-skid Surfacing Material

Tapered Fiberglass Platform Step



- Ergonomically designed
- Designed to fit Altec platforms
- P/N 660-60011 anti-skid surfacing material may be added to the stepping surface to prevent possible foot slippage
- Stepping surface measures 1' x 5 1/2"
- Overall mounting surface is 3 1/2'

P/N 704-00100 Tapered Fiberglass Platform Step
P/N 660-60011 Anti-skid Surfacing Material

Splicer's Seat & Toolbox



- 40% lighter than traditional wooden models
- Molded from durable, impact resistant plastic, it is virtually indestructible
- Impervious to oils, dirt, grease and a broad range of chemicals
- Opening is large enough to stow tools inside, but small enough to prevent them from falling out
- P/N 9701-75155

padded seat with tool pockets offers a large pocket that holds connectors, three tool pockets to store drivers, pliers and other small hand tools, and a leather knife sheath with a screwdriver holder and a quick release snap



P/N 9700-82370 SST-10 Splicer's Toolbox
P/N 9701-75155 212003 Seat - Extra Padding

PLATFORM COVERS

PLATFORM ACCESSORIES

Soft Vinyl Platform Cover with Drawstraps & Clamp



- Designed to fit Altec personnel platforms
- The nylon core is covered with black vinyl
- Drawstraps and clamps allow for securing the covers to the platform

	BLACK	YELLOW	ORANGE
24" x 24" 1 man soft vinyl cover	P/N 706-80049	P/N 9700-89632	P/N 704-20938
24" x 30" 1 1/2 man soft vinyl cover	P/N 704-20070	P/N 9700-89633	P/N 9700-89628
24" x 48" 2 man soft vinyl cover	P/N 704-20069	P/N 704-20940	P/N 9700-89629
Derrick soft vinyl cover*	P/N 706-80005	P/N 9700-89634	P/N 9700-89630
Derrick soft vinyl cover**	P/N 706-80616		

* For Derricks built before 01/2003

**For Derricks built after 01/2003

Vinyl-Coated Nylon Platform Cover with 2" Thick Foam Sewn In



- This soft, vinyl-coated water-shedding cover keeps rain, sleet, and snow out of the platform
- Includes a 4' lanyard with brass swivel snap and a 3/4" elastic rope sewn into the hem
- Reversible cover to give twice the life
- 2" thick piece of foam sewn in

	BLACK	YELLOW	ORANGE
24" x 24" 1 man vinyl-coated nylon cover	P/N 9000-67010	P/N 9700-89635	P/N 9700-89651
24" x 30" 1 1/2 man vinyl-coated nylon cover	P/N 0704-20810	P/N 9700-89641	P/N 9700-89653
24" x 48" 2 man vinyl-coated nylon cover	P/N 8130-00603	P/N 9700-89642	P/N 9700-89655

Heavy Vinyl-Coated Nylon Platform Cover



- This heavy vinyl coated cover comes equipped with a lanyard a snap hook to keep the cover with the truck
- Hem has a heavy bungee cord to maintain a tight fit

- Fits 1 or 1 1/2 man platform (circular)
- Fits 1 1/2 man platform (circular in shape)
- Fits 2 man platform
- Fits 6 sided platform
- Fits digger derrick platforms with brake cover

	BLACK	YELLOW	ORANGE
	P/N 7017-03102	P/N 8851-02711	P/N 9700-89685
	P/N 706-80468	P/N 9000-99959	P/N 9700-89696
	P/N 706-80469	P/N 8851-20004	P/N 9700-89705
	P/N 704-20071		
	P/N 706-80472		

Rigid Polyethylene Platform Cover



- Keeps the platform dry when not in use, sealing the bucket against rain, ice and snow
- Easy to install and remove
- May be installed with or without the liner in place
- Replacement strap sets are available

- P/N 0704-20067 Fits a one man platform
- P/N 0704-20695 Fits a 1 1/2 man platform
- P/N 0704-20066 Fits a two man platform
- P/N 9000-65400 Fits a 6-sided platform
- P/N 9000-99346 Replacement Strap for the P/N 704-20067 and P/N 9000-65400 cover
- P/N 9000-99983 Replacement Strap for the 704-20695 cover
- P/N 9000-99345 Replacement Strap for the 704-20066 cover

- Replacement strap sets are available

ALTEC SUPPLY Round Soft Spicer Platform Cover



- Soft cover with control guide
- Round spicer platform cover
- Black
- Replacement strap sets are available

P/N 9000-68410

Rigid Oversized Platform Cover



- 54.5" x 30"
- Shock cord ensures that lid will stay with platform
- Rigid, polyethylene material
- Includes strap to secure lid to platform

P/N 9000-41104 Two Man Platform Cover

USA: 1-877-GO ALTEC
(1-877-462-5832)

www.alteconnect.com

Bucket Stick Storage Case



Hold any size bucket stick.

- Molded from a tough waterproof polymer
- Clips to any size bucket with no drilling
- Includes drainage holes
- Lid is secured to base eliminating accidental dropping
- Fits stick probe in any direction
- Slant opening allows stick removal from the base

P/N 9702-11830 USBC-001 Bucket Stick Storage Case



USA: 1-877-GO ALTEC
(1-877-462-5832)

Boom Holster



Two-piece boom mounted hot stick holder. Spring loaded for easy access from platform. Adjustable and spring loaded to fit any size stick on any size boom.

P/N 9705-45595

USBC-002 Boom Holster Fits any size Boom

www.alteconnect.com

Bucket Mate Polymeric Hook



Extremely tough bucket hook.

- Machined from high performance polymer
- Blanket friendly tapered ends prevent cracks around holes
- Holds platform accessories from both inside and outside the platform

P/N 9703-35344 USBM-004 Bucket Mate Polymeric Hook

P/N 9703-35345 USBM-004W Wide Slot Bucket Mate Polymeric Hook





Heat Stress Solution Water Coolers & Ice Chests

Front of coolers & chests are imprinted with bilingual guidelines for avoiding heat stress



Legend 48 Heat Stress

- 52 Quarts/49 Liters
 - Holds 39 twenty oz sports bottles
 - Ultratherm® insulation keeps contents cold
- P/N 9705-88798 48228

Heat Stress Coolers

- Unsurpassed cold retention in the industry - maintains ice for over 3.5 days at 90°F!*

P/N 0685-00015 48153 5 Gallon *Jobsite "high performance" cooler!*
 P/N 9000-00213 48154 10 Gallon



Heat Stress Ultra™ 120 Qt Cooler

- 120 Quarts/114 Liters
- Holds 188 cans
- Ultratherm® insulated body and lid
- Holds ice up to 5 days

P/N 9704-51745 44266

Yukon 70 Qt Cold Locker

- Yukon 70 Qt Cold Locker
- 70 Quarts/66 Liters
- White w/ UV
- 3" foam in lid, 2" in body – 7 day performance*
- All stainless hinge rods and hardware

P/N 9706-01305 44667

*Under controlled test conditions



Workman 30

- 30 Quarts/28 Liters
- Holds 41 cans – Holds 2L bottles upright
- Cool Riser Technology™ improves cooling performance

P/N 9706-01307 43295



TRUCK ACCESSORIES

USA: 1-877-GO ALTEC
(1-877-462-5832)

www.alteconnect.com



PELICAN™

ProGear™ Elite Coolers / Ice Chest Series

Boasting **Best In Class 7-10 DAY Ice Retention** & Pelican's Unconditional Lifetime Guarantee.

PACK A TOUGHER, COLDER COOLER

- Injection Molded Swing handles with overmolded grip
- Best in class ice retention
- UV Protected Shell
- Durable Rotomolded Shell
- Made in the USA
- Unconditional Lifetime Guarantee
- Fish measuring ruler molded on lid
- Easy open locking latches
- Threaded leak proof recessed drain plug

ProGear™ Elite Coolers / Ice Chest Series

ALTEC	PELICAN	SIZE	COLOR	INTERNAL DIMENSIONS	EXTERIOR DIMENSIONS	WEIGHT
9706-22247 9706-22254	32-20Q-MC-WHT 32-20Q-OC-TAN	20Q	WHITE TAN	14.75"L x 10"W x 8.75"D	20.12"L x 15.07"W x 14.12"D	16 lbs.
9706-07780 9706-07789	32-35Q-MC-WHT 32-35Q-OC-TAN	35Q	WHITE TAN	15.75"L x 12.00"W x 11.50"D	26.41"L x 20.00"W x 18.75"D	32.28 lbs.
9705-95187 9705-87448	32-45Q-MC-WHT 32-45Q-OC-TAN	45Q	WHITE TAN	19.00"L x 12.00"W x 12.00" D	29.66"L x 20.00"W x 19.25"D	35.8 lbs.
9705-71107 9706-22257	32-65Q-MC-WHT 32-65Q-OC-TAN	65Q	WHITE TAN	26.50"L x 12.00"W x 12.50"D	37.16"L x 20.00"W x 19.75"D	47.91 lbs.
9705-71108 9705-22258	32-95Q-MC-WHT 32-95Q-OC-TAN	95Q	WHITE TAN	37.75"L x 20.00"W x 24.88"D	27.34"L x 12.00"W x 17.62"D	51 lbs.
9706-22265 9706-07789	32-150Q-MC-WHT 32-150Q-OC-TAN	150Q	WHITE TAN	34.00"L x 17.00"W x 15.75"D	44.88"L x 25.00"W x 24.68"D	66 lbs.
9706-22268 9706-22271	32-250Q-MC-WHT 32-250Q-OC-TAN	250Q	WHITE TAN	50.25"L x 17.00"W x 17.50"D	61.13"L x 27.50"W x 27.50"D	92 lbs.

Accessories

ALTEC	PELICAN	Description
9706-22272	35-45-65-WB	Dry Rack Wire Basket for 35, 45, 65, and 95 Quart Chests
9706-22273	150-250-WB	Dry Rack Wire Basket for 150 and 250 Quart Chests
9706-22274	C-TD-KIT	Cooler Tie-Down Kit

TRUCK ACCESSORIES

USA: 1-877-GO ALTEC
(1-877-462-5832)

www.alteconnect.com



P/N 9706-22268
250 Quart

P/N 9706-22265
150 Quart

P/N 9705-71107
65 Quart

P/N 9705-71108
95 Quart

P/N 9705-95187
45 Quart

P/N 9706-07780
35 Quart

138

P/N 9706-22247
20 Quart



COOLERS & ACCESSORIES



Igloo® 44677 Marine 25 Qt Cooler

- Ultratherm insulation keeps water food beverages or medical supplies cool and withstands tough job conditions or repeated use such as medical transport
- The insulated body keeps contents cold longer UV inhibitors guard against sun damage and the stain and odor resistant liner stays clean and odor free
- Can be secured by handles to the bed of a truck for safe transport
- Reinforced swing up handles with tie-down feature. All stainless steel screws



P/N 9704-69112 Igloo 44677

P/N 9700-42910 Custom Bracket Flat Bottom Tray for Igloo 44677 20.71" Long x 13.71" Wide x 6" High

Igloo® Breeze Max Cold Rolling Cooler

- 50 qt
- Maxcold five day performance
- Ice blue
- Telescopic handle
- Holds sixty nine cans
- Wide grip handles
- Molded side handles
- Tie down loops allow extra gear to be tied on top
- Insulated lid for maximum cold retention



P/N 9703-07118 45071

Igloo Water Coolers

- Sturdy plastic water coolers help keep plenty of fresh drinking water on hand at the job site
- Constructed of durable plastic that won't rust or fade in direct sunlight
- A sanitary white liner is surrounded by insulation, which helps keep beverages cool
- Wide-mouth, pressure fit lid with a mold-in contour handle for easy filling
- "Drinking water" imprint meets OSHA requirements



P/N 685-00012 2 Gallon
P/N 685-00025 3 Gallon

Rubbermaid 5 Gallon Water Cooler



- Built to take the rugged abuse working in the field can bring
- Splash seal prevents leaks
- Liner stands up to stains and odors
- Double wall construction with extra-thick insulation
- Fast-flow faucet is recessed to protect from breaking
- Heavy-duty, side-folding, no-pinch handles
- Insulated liner keeps drinks hot or cold

P/N 9007-50621 5 Gallon

Cup Dispenser

- This convenient black plastic cup dispenser is especially designed for cone-style cups.
- Fits all plastic water coolers except the 2-gallon cooler
- Designed for 4 or 4 1/2 oz, rolled-edge, cone style cups (P/N 9000-00189)

P/N 685-00005



Aluminum Water Cask Bracket



- Attaches to your truck for mobility of beverage coolers
- Made of sheet metal and features an easy-to-use bungee cord design

P/N 685-00077

TRUCK ACCESSORIES

USA: 1-877-GO ALTEC
(1-877-462-5832)

www.alteconnect.com

WHEEL CHOCKS

Wheel Chocks

OSHA requires wheel chocks for vehicles over 3/4 ton when parked on an incline or when being loaded or unloaded by a power lift. Make sure your vehicle or trailer is properly chocked with these sturdy chocks.



P/N 9000-70175



P/N 0660-01017



P/N 0660-01023



P/N 9000-70327



P/N 660-01044



P/N 8140-00728

Altec offers a wide selection of chocks with options that include shape of chock, hollow or solid, and handle configuration. To order a wheel chock style that is not listed, please call 1-877-GO ALTEC.

- P/N 9000-07280 Wheel Chock (Wooden) with Metal Handle
9" x 10" x 5" 9 lbs.
- P/N 9000-70175 Wheel Chock (Wooden), Metal Handle/Thru Bolts
9" x 10" x 5" 9 lbs.
- P/N 9000-06409 Spiked Shoes add extra grip for icy surfaces and loose dirt or gravel (order two per chock)
1 lb. each
- P/N 0660-01017 Rubber Wheel Chock with Metal Hairpin Handle
9 3/4" x 7 3/4" x 5" 10 lbs.
- P/N 8786-60011 Metal Wheel Chocks
9" x 11" x 5" 10 lbs.
- P/N 9000-70327 Wheel Chock (Hardwood) with Steel Tread
6" x 9" x 10" 11 lbs.
- P/N 660-01044 Steel Wheel Chock
9" deep x 10" high x 12 3/4" tall
- P/N 8140-00728 Rubber Wheel Chocks
Set of two chocks connected by rope
7 1/2" x 8" x 10"

OUTRIGGER PADS

Composite Outrigger Pads



- Lightweight, non-conductive, and moisture resistant
- Stronger than the average wood, plywood, or cast metal outrigger pads
- Pad will return to its original shape once load is removed
- Resistant to chemicals, solvents, oils

- P/N 0692-93078 ("A") Composite 22" x 22" x 1"
- P/N 9000-93078 ("B") Composite 22" x 22" x 1" (Non-Skid)
- P/N 9703-24726 18" x 18" x 1"

Composite Outrigger Pads for Altec Backyard Digger Derrick



- Lightweight, non-conductive, moisture-resistant
- Stronger than the average wood, plywood, or cast metal outrigger pads
- Pad will return to its original shape once load is removed
- Resistant to chemicals, solvents, and oils

- P/N 9701-09032 18" x 18"

Wooden Outrigger Pads



- Adds stability and safety in soft grass, acting as a "shoe" for the outrigger, reducing pits, depressions, cracks, and other damage to pavement and grass
- Dimensions: 24" x 24" x 3"
- Lightweight, compact, and easily stored on truck

- P/N 0692-93117 Wood 15" x 24" x 3"
- P/N 0692-93119 Wood 18" x 18" x 3"
- P/N 0692-93118 Wood 24" x 24" x 3"

Aluminum Outrigger Pads



- Aluminum/magnesium does not waterlog, crack, or splinter like wooden pads
- Dimensions: 24" x 24" x 3"
- Aluminum/magnesium pads are strong, yet lightweight
- Engineered design prevents slipping and sinking

- P/N 0692-93099 Aluminum 14" x 26" x 2 1/2"
- P/N 0692-93055 Aluminum 18" x 18" x 2 1/2"
- P/N 0692-93081 Aluminum 24" x 24" x 3"

AlturnaMATS®

"The Original Ground Protection Mat"

World's Largest
Manufacturer
of Ground
Protection Mats



ALTURNAMATS®

AlturnaMATS® virtually eliminate damage to lawns and landscaped areas and provide traction for vehicles operating in mud or sand. From North America, Asia, Australia, Europe and even Antarctica, these are the preferred mats among professionals across the industry. AlturnaMATS are easy to use, they lock into place to form a continuous, solid working roadway or platform, and they last for years.

- Prevent scarring and disruption of surfaces in yards, golf courses, parks, medians, other grassy or soft areas
- Durable 1/2" thick 100% polyethylene
- Withstands 120 ton loads and record heat/cold
- Reuse hundreds of times
- Will not splinter nor become slippery like plywood
- Proven best diamond plate design

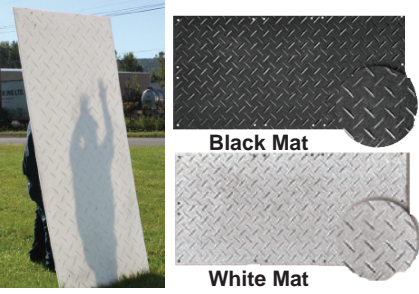

Mat Size	Weight	Black Mats	White Mats	Clear Mats
4'X 8'	86 lbs.	900021810	970071145	970650203
3'X 8'	64.5 lbs.	970021819	970071150	970650205
3'X 6'	51 lbs.	-	-	970650206
2'X 8'	43 lbs.	970029104	970071153	970650208
2'X 6'	32.25 lbs.	970071445	970071155	970650210
2'X 4'	21.5 lbs.	970071447	970071156	970650211

P/N 9700-39309 (Above Left)
P/N 9700-39328 (Above Right)

Mat Accessories	
970039308	Handi-Hook Accessory
970039309	Round Turn-A-Link - Single
970039325	Flat Turn-A-Link - Single
970039327	Flat Turn-A-Link - Double
970039328	Round Turn-A-Link - Double



(Left to Right: Clear Mat, White Mat, Black Mat)

AlturnaMATS now offers the CLEAR mat.

Grass needs sunlight and air to survive. Effects after 5 days: Black mats show heavy browning of grass & burnt leaves. White mats show moderate browning & slightly burnt leaves. Clear mats show NO damage. The choice is CLEAR!

OUTRIGGER PADS



- Solid construction; safety textured
- Lightweight, HEAVY-DUTY pads
- No delamination
- Safety orange rope handles
- No splinters
- Recovery memory
- No warping after bending

Part Number	Model	Load Capacity		Size
		Vertical	45° Angle	
P/N 9702-01144	PAD1515.75	45,000#	20,000#	15" x 15" x .75"
P/N 9701-33273	PAD18181	55,000#	30,000#	18" x 18" x 1"
P/N 9702-01146	PAD24241	60,000#	35,000#	24" x 24" x 1"
P/N 9701-08329	PAD24242	62,000#	40,000#	24" x 24" x 2"

Specialty Outrigger Pads are Available. Please call 1-877-GO ALTEC (1-877-462-5832) for more information.

MAT-PAKS

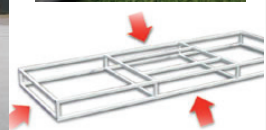

- All-in-one ground protection solution
- 12 - 4'x 8' or 3'x 8' Ground Protection Mats
- 1 - AMRK Turn-A-Rack Storage and Transportation Rack with four (4) way fork lift entry
- 20 - RTL-S Turn-A-Links Locking mats together
- 2 - AMHH Handi-Hooks
- Custom Nylon Ratchet Straps

Original Black Mats

P/N 9701-22731	AMCP4	4' X 8'	1132 lbs.
P/N 9701-80809	AMCP3	3' X 8'	847 lbs.

Original White Mats

P/N 9702-01147	WMCP4	4' X 8'	1132 lbs.
P/N 9702-01148	WMCP3	3' X 8'	847 lbs.

TRUCK ACCESSORIES

USA: 1-877-GO ALTEC
(1-877-462-5832)

www.alteconnect.com

Please contact your Altec Supply Account Manager for more information regarding quality Alturnamats products.





**GROUND COVER MATS & OUTRIGGER PADS
THAT GET YOU IN AND OUT
AND GET THE JOB DONE!**

PORTABLE ROADWAY SYSTEMS

TRUCK ACCESSORIES

USA: 1-877-GO ALTEC
(1-877-462-5832)

www.alteconnect.com

MUD-TRAKS®

- Strongest "Man-Handlable" mat in the industry
- Super strong, light weight fiberglass design
- Rigid panel reduces 75 psi tire load to 11 psi ground load
- Most aggressive traction surface available
- Cool Off-White color prevents heat damage to lawn
- Rope handles standard offer easy handling
- Non- conductive, great for power line work
- Unaffected by water, gas, oil or chemicals
- Steel Connectors available to create roadway

OFF-ROAD SUPER MATS: Vehicle Weight up to 100,000 lbs.

Off White	SVE	Dimensions	Weight
9704-44192	N3272HDS	32" X 6' X 0.40"	48 lbs.
9704-44193	N3296HDS	32" X 8' X 0.40"	66 lbs.
9704-44194	N4572HDS	45" X 6' X 0.40"	74 lbs.
9704-44195	N4596HDS	45" X 8' X 0.40"	103 lbs.

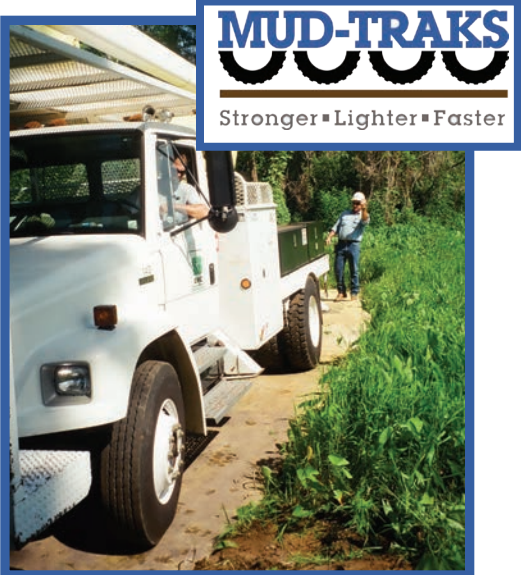

TRAKMAT®

- No ruts, Damaged Lawns, or Weather Delays
- Tough 1/2" thick polyethylene; Won't break!
- Superior Traction; "Power Cylinder" Tread Design
- "Cool Green" Color (prevents grass burnout) or Utility Black
- Easy Lifting with hand cutouts; standard
- Loads effortlessly with unique tread design
- Smooth surface on one side available
- Connectors & U-Stakes Available
- 6 Year Limited Manufacturer's Warranty

Cool Green	Utility Black	SVE	Dimensions	Weight
9704-44197	9703-64921	TM4496	44.5" X 8'	78 lbs.
9704-44198	9704-44202	TM3696	36" X 8'	64 lbs.
9704-44199	9704-44203	TM3672	36" X 6'	51 lbs.
9704-44200	9704-44204	TM2296	22.2" X 8'	39 lbs.

OUTRIGGER PADS

- Engineered Composite Fiberglass Pads
- Super Strong & Light Weight
- Non-skid surface traction surface
- Unaffected by Water, Oil or Chemicals

Small Backyard Units:

P/N 9704-44208 1616HD (16" X 16' X 5/16") 5 lbs.

Vehicles Up To 35,000 lbs; Single Rear Axle:

P/N 9704-44209 1818 (18" X 18" X 0.6") 10 lbs.

P/N 9704-44210 2424 (24" X 24" X 0.6") 20 lbs.

Vehicles Up To 70,000 lbs; Tandem Rear Axle:

P/N 9704-44211 3232 (32" X 32" X 0.6") 30 lbs.

Vehicles Up To 100,000 lbs; Tandem Rear Axle:

P/N 9704-44212 4545 (45" X 45" X 0.6") 60 lbs.



MAGNUM DIMENSIONS

Quiet, Pure, Rugged AC Power

Dimensions is proud to offer our premium, American made, pure sine inverters. Our patented low frequency design can handle the rigors of any industrial application. When the mission is critical, your reliable AC power is made by Dimensions.



LF Pure Sine - 4 Year Warranty		
P/N 8939-51500	ALT 12/400N	400 WATTS
P/N 7011-22129	ALT 12/800N	800 WATTS
P/N 8780-71067	ALT 12/1200N	1200 WATTS

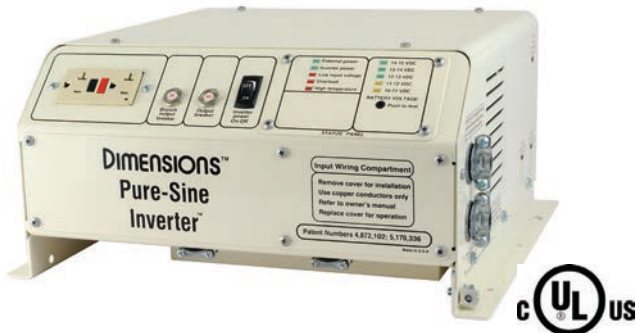

LF Pure Sine - 4 Year Warranty		
P/N 0604-60006	ALT 12/1800N	1800 WATTS
P/N 8939-64100	ALT 12/2400N	2400 WATTS
P/N 0604-60002	ALT 12/3000N	3000 WATTS
P/N 7011-22131	ALT 12/3600N	3600 WATTS

Sensata Series

HF Pure Sine - 2 Year Warranty		
P/N 9703-51621	SSI-12HF3.5N	350 WATTS
P/N 9702-15724	SSI-12HF7N	700 WATTS
P/N 9703-51626	SSI-12HF10N	1000 WATTS
P/N 9702-15726	SSI12HF15N	1500 WATTS



TRUCK ACCESSORIES

USA: 1-877-GO ALTEC
(1-877-462-5832)

www.alteconnect.com

Get Organized

with SVP Mobile Systems from Altec

TRUCK ACCESSORIES

USA: 1-877-GO ALTEC
(1-877-462-5832)

www.alteconnect.com



10-CVAN12 with Locking iPad Tray & Locking Console Arm Mount



10-SCE12
P/N 7012-09003 10-SCE12



10-PGE12
P/N 9704-43383 10-PGE12

AEP Tall & Xtreme Pedestal

Highly versatile mobile office workstation which allows the user to combine all of their electronics, storage, switch boxes, file management and radio. Works with any medium to large truck or van that has a removable center seat or existing space between the front seats.



10-AEPTall12
P/N 9703-98260 AEPTall12
(shown here with both Rugged Xtreme & Radio mounts)



Locking iPad Tray
P/N 9705-59119 4-iPad Tray-Lk
*easily mounted on consoles

MAKE THE RIGHT CHOICE

Comparison between the Rugged Heavy Duty & the SW1 Medium Duty pedestal mounts



Rugged heavy duty **SW1 medium duty**

All the differences between the SW1 Medium duty and the Rugged Heavy duty pedestal mounts are designed to stiffen the mount for heavy duty vehicles and off road driving. The SW1 pedestal is great for sedans, most vans and light duty trucks used on hard surface roads. The Rugged pedestal was designed for Utility companies who have heavy duty vans and trucks that regularly need to traverse unpaved and unimproved roads. Both systems work well when used in the proper vehicle and during the design scenario.

We hope this info helps you make the right choice for your situation

Leading the Way through Innovation & Quality



CONSOLES LAPTOP & IPAD MOUNTS MOBILE ACCESSORIES



*Rugged Xtreme
Spring-loaded
Laptop Tray*



SVP Mobile Systems
 **VETERAN OWNED BUSINESS**

Rugged Xtreme

Ergonomically friendly Laptop Mount, Safe & Secure Technology System employs a pedestal mount and non-locking top. Reduce strain on neck, shoulders and back to increase the health and well-being of mobile workers. Available in Drill or No-Drill Base options.



Rugged Fuzion

P/N 9703-98254 Drill Mount
 P/N 9703-98255 No-Drill Mount w/ Riser VB
 P/N 9703-98256 No-Drill Mount VB w/o Riser

Rugged Fuzion

Extremely Heavy Duty Laptop Stand, widely used by utility, service and safety professionals that need functionality and theft prevention. Heavy Duty performance with ergonomic benefits that increase productivity and provide a comfortable mobile computing experience. Includes locking top & pedestal. Available in Drill or No-Drill Base options.

Rugged Xtreme
 P/N 9703-98257 Drill Mount
 P/N 9703-98258 No-Drill Mount w/ Riser VB
 P/N 9703-98259 No-Drill Mount VB w/o Riser



10-CArm-Lk
 P/N 9705-59122 4-CArm-Lk
 (shown with Locking iPad Tray mounted on 10-CVAN12)

Heavy Duty work environments need an extreme mounting system to keep you working safely.

*Available for iPad/Tablet or Laptops



*Rugged Fuzion &
Locking Laptop Mount*

SVP Mobile Systems thru Altec Call Today
1-877-GO ALTEC

TRUCK ACCESSORIES

USA: 1-877-GO ALTEC
 (1-877-462-5832)

www.alteconnect.com





CONSOLES • LAPTOP & iPad MOUNTS • MOBILE ACCESSORIES



SVP Mobile Systems
VETERAN OWNED BUSINESS

Pedestals



Medium Duty SW1

P/N 9705-58880 Drill Mount
P/N 9705-58884 No-Drill Mount w/ Riser VB
P/N 9705-58886 No-Drill Mount w/ VB w/o Riser



Rugged Fuzion

P/N 9703-98254 Drill Mount
P/N 9703-98255 No-Drill Mount w/ Riser VB
P/N 9703-98256 No-Drill Mount w/ VB w/o Riser



Rugged Xtreme

P/N 9703-98257 Drill Mount
P/N 9703-98258 No-Drill Mount VB w/ Riser
P/N 9703-98259 No-Drill Mount VB w/o Riser

Consoles

= Locking Console



10-SCE12
P/N 7012-09003 10-SCE12



10-SFile12
P/N 9702-86800 10-SFile12



10-7000.12
P/N 9703-98263 10-7000.12



10-7000Bench12
P/N 9705-58862 10-7000BENCH12



10-Bench12
P/N 9705-58865 10-BENCH12



10-CVAN12
P/N 9703-98262 10-CVAN12



10-PGE12
P/N 9704-43383 10-PGE12



10-AEP12
P/N 9705-58870 10-AEP12



10-AEPTall12
P/N 9703-98260 10-AEPTall12



10-5000.12
P/N 9705-58879 10-5000.12



Locking iPad/Tablet Tray
P/N 9705-59119 4-iPad Tray-Lk



Locking Console Arm Mount
P/N 9705-59122 4-CArm-Lk



Trek Pedestal
P/N 9705-58934 Drill Mount
P/N 9705-58936 No-Drill Mount w/ Riser VB
P/N 9705-58938 No-Drill Mount w/ VB w/o Riser



10-SDGE12
P/N 9703-20098 10-SDGE.12

Locking Console Mount
P/N 9705-59110 4-CMount-Lk

TRUCK ACCESSORIES

USA: 1-877-GO ALTEC
(1-877-462-5832)

www.alteconnect.com

SVP Mobile Systems thru Altec Call Today
1-877-GO ALTEC



ALTEC BACK-UP CAMERA



P/N 9702-94018 Camera



P/N 9702-94017 Monitor



P/N 9702-94019 Cable

- 'Button-lock' anti tamper feature
- 2 Auto-triggers
- Mirror/normal switching from menu
- Audio
- Sun shield; Auto-dimmer
- Multi-lingual menus
- Auto-switching PAL/NTSC
- Monitor and camera include basic mounting equipment
- Power consumption: 8.4 Watts; Current: .28 Amps

Picture Quality

- Resolution: 480 x 3 x 234; Brightness: 450cd/m²; Contrast Ratio: 250:1
- Anti-glare screen; LED backlighting (20,000 hour life)
- Viewing angles: side 60° x top 30° x bottom 60°

Durability & Standards

- Mechanical vibration: 10G; Mechanical shock: 100G
- Operating temperature: -40° C to +70° C
- CE marked; EMC approved: E; ISO 13766:2006; ISO 16750

- P/N 9703-12497 Complete Kit
- P/N 9702-94017 Monitor
- P/N 9702-94018 Camera
- P/N 9702-94019 Cable

FEDERAL SIGNAL BACK-UP CAMERA

Rear Camera System



- Features (1) 5.6" color TFT LCD monitor, (1) rear camera with built-in microphone and day/night sensor, (1) 65.5' camera cable and accessories

P/N 9701-57236 CAMSET56-NTSC-2

Mobile Camera Systems



- TFT-LCD color monitor
- High-resolution, color Sony® CCD Camera
- Camera equipped with day/night sensor
- Three-year product warranty

P/N 9701-57236 CAMSET56-NTSC-2
5.6" monitor with 2 camera input, standard rear-view camera

P/N 9703-29767 CAMSET70-NTSC4B 7.0" monitor with 4 camera input, standard rear-view camera

TRUCK ACCESSORIES

USA: 1-877-GO ALTEC
(1-877-462-5832)

www.alteconnect.com



Console-X

The Console -X is the latest innovative mobile office solution to join the Mobile Desk brand family of products. This complete control, communication and convenience Utility Truck Console is becoming the new standard for fleets of all sizes. The design of the Console-X has originated from our years of experience of working directly with the lineman, supervisors, communications and fleet of some of the most notable utility companies in America.

The Console-X features a number of standard and optional integrations that maximizes your field force productivity. The integrated computer mount option features an ergonomic double articulating arm with height adjustment and a positive stop tilt and turn.

Choose from one our locking laptop trays with shock control, any of our available docking stations or bring your own dock. The tilt and turn hole patterns will match up with most major laptop docking stations.

P/N 9706-37347 VC-ALTCS-00 Console-X for Chevy and GMC Trucks 1500-5500

No Drill Base Mount, Cupholders, Large Storage Compartment with Filing Rails, Writing Surface, Spring Loaded Clipboard, 12 Port 200 amp Power Panel, Harness, 3 ea 12 Volt Outlets, 1 ea 2.1 Amp USB Radio Slot.

P/N 9706-37348 VC-ALTDR-00 Console-X for Dodge Ram Trucks 1500-5500

No Drill Base Mount, Cupholders, Large Storage Compartment with Filing Rails, Writing Surface, Spring Loaded Clipboard, 12 Port 200 amp Power Panel, Harness, 3 ea 12 Volt Outlets, 1 ea 2.1 Amp USB Radio Slot.

P/N 9706-37349 VC-ALTF150-00 Console-X for Ford F-150 Trucks

No Drill Base Mount, Cupholders, Large Storage Compartment with Filing Rails, Writing Surface, Spring Loaded Clipboard, 12 Port 200 amp Power Panel, Harness, 3 ea 12 Volt Outlets, 1 ea 2.1 Amp USB Radio Slot.

P/N 9706-37350 VC-ALTFSD-00 Console-X for Ford F-250-550 Super Duty Trucks

No Drill Base Mount, Cupholders, Large Storage Compartment with Filing Rails, Writing Surface, Spring Loaded Clipboard, 12 Port 200 amp Power Panel, Harness, 3 ea 12 Volt Outlets, 1 ea 2.1 Amp USB Radio Slot.

P/N 9706-37351 VC-ALTINTL4000-00 Console-X for International 4000-7000 Series Trucks

No Drill Base Mount, Cupholders, Large Storage Compartment with Filing Rails, Writing Surface, Spring Loaded Clipboard, 12 Port 200 amp Power Panel, Harness, 3 ea 12 Volt Outlets, 1 ea 2.1 Amp USB Radio Slot.

P/N 9706-37352 VC-ALT-FLM2-00 Console-X for Freightliner M2 Trucks

No Drill Base Mount, Cupholders, Large Storage Compartment with Filing Rails, Writing Surface, Spring Loaded Clipboard, 12 Port 200 amp Power Panel, Harness, 3 ea 12 Volt Outlets, 1 ea 2.1 Amp USB Radio Slot.

HIGHLIGHTS

- Consolidates all of your Electronics
- Facilitates and Simplifies Fleet Standards Protocols
- Use with Existing Bucket and Split Bench Seats
- Steel Construction with an Expected 25 Year Life Cycle
- No-Drill Base Installation
- Multiple Electronic Configurations
- Customizable to your Specifications

INCLUDES ALL OF THESE FEATURES:

- Console-X Shell
- Existing Radio Slot
- Integrated Cup Holders
- Integrated Storage
- File Rail System
- Integrated Spring Loaded Clipboard
- No-Drill Base Mount
- 200 Amp 12 Circuit ATC Block
- (3) 12 volt 10 AMP Receptacles
- (1) 2.1 Amp USB Charging Port
- Integrated 12 Circuit Electronics Wiring Harness (4 each for 12V ports)
- Integrated Laptop Mount Support (The external tube portion only)
- Internal Speaker Mounting w/Slotted Panels for Sound Distribution

OPTIONAL FEATURES:

- Optional Tough Desk Ultra Laptop Arm and Pedestal
- Optional Tough Desk Ultra High Security Laptop Tray
- Optional Tough Tab Ultra High Security Tablet Tray
- Optional Console Armrest Assembly and Bracket (driver side)
- Optional Magnetic Mic Clip
- Optional Hand Held Radio or Cell Phone Mount
- Optional Printer Mount for Printer Mount for Console-X
- Optional Electronics Switch Integration
- Optional Front Opening Screen
- Optional 600 Watt Pure Sine Wave Inverter
- Optional 75 Amp Relay Kit for 60 Watt Inverter
- Optional 75 Amp Automatic Timer For Electronics (PDU)



Screen Out

Patents Pending



TRUCK ACCESSORIES

USA: 1-877-GO ALTEC
(1-877-462-5832)

www.alteconnect.com

Screen Out™ Screen Blanking and Keyboard Disabler Technology

Screen Out is the latest safety innovation from Mobile Office Solutions to join the Mobile Desk brand.

Screen Out is a hardware/software solution that is designed to blank a mobile user's laptop screen and / or render the keyboard and mouse inactive when it senses the motion of the vehicle.

The connection is made by way of a wired or wireless connection through the Screen Out™ OBDII trigger device.

The robust features and capabilities of Screen Out have been developed and refined from our 10 years of extensive research and development working with the utility industry field force.

Screen Out addresses many of the driver distraction concerns of any company that has mobile computer users that work out of their vehicles.

Screen Out will make your fleet and communities safer by completely eliminating the in-vehicle computer as a distraction while the vehicle is moving.

Improve the Safety of Your Field Automated Workers with Screen Out Today!



Features

- Blanks the Computer Screen when the Vehicle is in Motion
- Will not Affect Users Outside of the Vehicle
- Works in Any Vehicle
- Transparent to the End User
- Disable your Keyboard and Mouse Only option
- You set the Activation Speed
- Wireless or Wired Technology
- Automatic Violation Reporting
- Plug, Pair and Play Technology
- Centrally or Locally Managed
- Works Instantaneously in Real Time
- Works In and Outside of the Vehicle
- No Monthly Subscription Fees
- Low Voltage Shut Off
- Does Not Interfere With Existing Softwares
- Eliminates the Computer as a Distraction
- Customizable Screen Overlay
- 100% Secure Bluetooth or Wired Technology
- Includes over 40 More Features

P/N 9706-37353 SCREENOUT For Windows OS
 P/N 9706-37354 SCREENOUTiOS For iPad or iPhone
 P/N 9706-38355 SCREENOUTiOs2 For iPad or iPhone



Tough Desk Ultra

The Tough Desk and Tough Desk Ultra is our latest Laptop Mount Innovation. The Tough Desk Series combines ergonomics and usability with a superior rugged design and high security.

The Tough Desk Ultra is rapidly becoming the new standard for fleets of any size. The ergonomic design of the Tough Desk line has originated from our years of experience working directly with the lineman, supervisors, communications, and fleets of some of the most notable utility companies in America.

Tough Desk Laptop Mounts feature a number of standard and optional integrations maximizing your field force productivity. Features include our ergonomic double articulating arm with height adjustment and a positive stop tilt and turn. Choose from one of our locking laptop trays with shock control, any of our available docking stations, or bring your own dock. Our tilt and turn hole patterns will match up with most major mfg docking stations.

Improve Your Mobile Office Environment Today



Features

- Perfect for All Laptops and Tablets Computers
- Double Articulating Arm
- Use with our Locking Laptop Tray or your Docking Station
- Fully Adjustable Height with Built in Stop
- High Security Locking Top Design (Pat Pending)
- Integrated Storage with Optional File Support
- Designed for Maximum Air Flow to your Computer
- Positive Stop Tilt and Turn (90 or 45 degree)
- Ergonomic Design /Reduces Fatigue and Injuries
- Stores Out of the Air Bag Zones for Safety
- Stable Super Heavy Duty Design
- Shock and Vibration Control Included
- Double Reinforced Channel Side Brackets
- Optional No-Drill Installation
- Optional Printer Mounts
- Optional Power Inverter and Bracket
- Optional Screen Holder Support
- Optional Stabilizer Supports
- Expected 25+ Year Life Span
- 5 Year Warranty (by Manufacturer)





LINK® Cat's Eye®

Tire Pressure Maintenance System

With the LINK CAT'S EYE® TIRE PRESSURE MAINTENANCE SYSTEM, dual tire pressures can efficiently be checked on walk-a-rounds with just a glance. The system attaches to the dual's hub or lug bolt and allows air transfer from one tire to the other. Its single airing point fills both tires at once, making the job quick, clean and easy. With just a glance, you'll instantly see changes in tire pressure.



Proper Inflation



Under Inflated



Severely Under Inflated

How to Read Your Cat's Eye:

- The bright yellow "eye" of the Cat's Eye opens up slightly if dual tire pressure falls 5-6% below the recommended pressure setting. When the eye is completely open, pressure has dropped 10-12% under the recommended pressure and needs immediate attention
- Internal check valve prevents both tires from going flat if one tire develops a leak, blows out, or a pressure hose is cut or broken
- Cat's Eye is available with rubber or stainless steel hoses in lengths of 12", 14" or standard 16"

	2 PACK - STAINLESS STEEL HOSES				4 PACK - STAINLESS STEEL HOSES			
	14" (19"-22" rims)		16" (22"-24" rims)		14" (19"-22" rims)		16" (22"-24" rims)	
60 PSI	970359383	6060AG00	970359397	6060AB00	970359411	6060BG00	970359426	6060BB00
65 PSI	970359384	6065AG00	970359398	6065AB00	970359412	6065BG00	970359427	6065BB00
70 PSI	970359385	6070AG00	970359399	6070AB00	970359413	6070BG00	970359428	6070BB00
75 PSI	970359386	6075AG00	970359400	6075AB00	970359414	6075BG00	970359429	6075BB00
80 PSI	970359387	6080AG00	970359401	6080AB00	970359415	6080BG00	970359430	6080BB00
85 PSI	970359388	6085AG00	970359402	6085AB00	970359416	6085BG00	970359431	6085BB00
90 PSI	970359389	6090AG00	970359403	6090AB00	970359417	6090BG00	970359432	6090BB00
95 PSI	970294264	6095AG00	970359404	6095AB00	970359418	6095BG00	970359433	6095BB00
100 PSI	970359391	6100AG00	970293019	6100AB00	970359419	6100BG00	970359434	6100BB00
105 PSI	970359392	6105AG00	970249912	6105AB00	970359420	6105BG00	970270709	6105BB00
110 PSI	970209369	6110AG00	970359407	6110AB00	970359421	6110BG00	970359436	6110BB00
115 PSI	970359394	6115AG00	970359408	6115AB00	970359422	6115BG00	970359437	6115BB00
120 PSI	970359395	6120AG00	970250371	6120AB00	970359423	6120BG00	970359438	6120BB00
125 PSI	970359396	6125AG00	970359410	6125AB00	970359424	6125BG00	970359439	6125BB00
130 PSI	-	-	-	-	970359425	6130BG00	970359440	6130BB00

12" Models, Accommodating 16-18" Rims, And Systems With Rubber Hoses Are Also Available.

THE REEL THING

- With higher load ratings stamped right on the tool, you can use The Reel Thing for a greater range of reel weights
- With a new flipping feature, this multi-use tool gives you more flexibility in the warehouse and in the field
- The Reel Thing allows one person to lift, stack, and spin cable spools
- P/N 9000-42000 and P/N 9000-40000 allow you to safely flip a reel from rolling to non-rolling position
- P/N 9700-56381 features a bearing swivel assembly to accommodate a weight of up to 12,000 lbs.
- Independent laboratory tested with the ASME code stamped right on the toggle bar

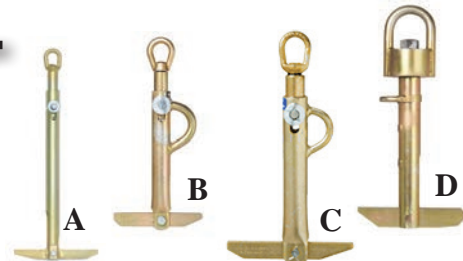

	Tulsa Power	Arbor Size	Capacity
A. P/N 9700-56375	RT-10	1.25" - 2"	500 lbs.
B. P/N 9000-42000	RT-20	2" - 4"	3,000 lbs.
C. P/N 9000-40000	RT-40	3" - 6"	4,500 lbs.
D. P/N 9700-56381	RT-60	2-5/8" - 6"	12,000 lbs.

TRUCK ACCESSORIES

USA: 1-877-GO ALTEC
(1-877-462-5832)

www.alteconnect.com

AIRCRAFT DYNAMICS™

TRUCK ACCESSORIES

USA: 1-877-GO ALTEC
(1-877-462-5832)

www.alteconnect.com

ROBO REELS

TRIPLEX AND GUY WIRE ROBOREELS ARE DESIGNED FOR LINEMEN TO PROVIDE AN EASY AND SAFE MEANS TO UNWIND AND REWIND CUMBERSOME WIRE AND CABLE. EXTREMELY RUGGED, ALL-WEATHER HEAVY-DUTY REELS. MADE OF STEEL AND E-COATED TO ENSURE LONG LIFE, ROBOREELS HAVE ADJUSTABLE ARMS THAT ALLOW AN EASY AND SECURE MEANS OF LOADING, UNWINDING AND REWINDING VARIOUS COILS WITH DIFFERENT DIAMETERS. COILS CAN BE SIMPLY ROLLED INTO THE STAND, AND WITH THE ADJUSTABLE ARMS, SECURELY CLAMPED INTO PLACE IN SECONDS. WIRE OR CABLE IS THEN EASILY PULLED OR REWOUND THROUGH SMOOTH CENTER GUIDES.



HORIZONTAL MOUNT TRIPLEX ROBOREEL

P/N 9703-89126 5456

- 4 adjustable arms
- Holds coils up to 8 3/4" Wide
- Accepts coil
 - Outside diameter 27" - 32"
 - Inside diameter 16" - 21"
- Dimensions: 14" H x 34" D x 34" W
- Weight: 37 lbs.
- ** Not compatible with quick change plate



PROUDLY MADE IN THE



TRIPLEX ROBOREEL

P/N 9701-02567 5478

- 8 adjustable arms
- Holds coils up to 10-1/4" Wide
- Accepts coil
 - Outside diameter 26" - 32"
 - Inside diameter 14" - 20"
- Dimensions: 34-1/2" H x 14" D x 33-1/2" W
- Weight: 58 lbs.

SMARTER

SAFER

STRONGER

AIRCRAFT ~~A~~ DYNAMICS™



GUY WIRE ROBOREEL

P/N 9701-04847 5276

- 4 adjustable arms
- Holds guy wire with 1/2" diameters
- Accepts coil
 - Outside diameter 22" - 31"
- Holds coils upto 4.75" wide
- Dimensions: 33 3/4" H x 9 1/4" D x 32 1/4" W
- Weight: 41 lbs.
- Wire can be pulled from either direction

LARGE GUYWIRE ROBOREEL

P/N 9701-98796 5415

- 4 adjustable arms
- Holds guy wire with 1/2" diameters
- Accepts coil
 - Outside diameter 32" - 36"
- Holds coils up to 8 3/4" Wide
- Dimensions: 36" H x 9 1/4" D x 34"
- Weight: 46 lbs.

ROBOREEL HITCH MOUNT ACCESSORY

P/N 9703-56907 5479

- Tight On Space? Securely mount RoboReels
- Fits 2" receiver hitch
- Swivel mount allows pulling any direction



ROBOREEL HITCH MOUNT ACCESSORY

P/N 9000-50214 5074

- Great space organizer.
- Ideal accessory for those who want a quick means to remove or remount your RoboReel



** Not compatible with horizontal reels

ROBO
REELS

TRUCK ACCESSORIES

USA: 1-877-GO ALTEC
(1-877-462-5832)

www.alteconnect.com

SMARTER

SAFER

STRONGER

REELTUFF™ INDUSTRIAL GRADE RETRACTABLE CORD REELS

RTB SERIES, 600V/30A RATED SLIP RING, UL LISTED

TRUCK ACCESSORIES

USA: 1-877-GO ALTEC
(1-877-462-5832)

www.alteconnect.com



REELTUFF INDUSTRIAL GRADE RETRACTABLE CORD REELS ARE DESIGNED FOR CONTINUOUS DUTY, HIGH CYCLE ENVIRONMENTS WHEN DELIVERING TEMPORARY POWER FOR REPAIR AND MAINTENANCE STATIONS, LEVEL TWO 240 VOLT FLEET CHARGING STATIONS, OR ENGINE BLOCK HEATERS.

NEMA 4 RATED FOR INDOOR OR OUTDOOR USE, INCLUDING WET LOCATIONS.
NEMA 2* RATED FOR INDOOR USE.

(*Cord reels are de-rated to NEMA 2 when accessories are added)

RTB REELS:

600-VOLT/30-AMP RATED
SLIP RING

ADJUSTABLE BALL STOP

6' FEEDER CORD INCLUDED

ALL STEEL CONSTRUCTION,
INCLUDING MOUNTING BASE

ADJUSTABLE RATCHET CAN BE
ENGAGED (POSITIVE LOCK) OR
DISENGAGED (CONSTANT
TENSION)AS NEEDED

MOUNT ON OPTIONAL PIVOT

BASE
FOR 345 DEGREE ROTATION

CORROSION RESISTANT POWDER
COAT FINISH IN EITHER STANDARD
SAFETY YELLOW OR NEW WHITE



Configuration (payout end)	Cord Length	Gauge/ Conductor	Cord Type/ Color	Volts	Max Amps	Slip Ring Rating	NEMA Plug	NEMA Rating	Altec	Model #
Yellow Powder Coated Cord Reels - NEMA 4 Indoor/Outdoor Use										
Blunt Ends	25'	16/3	SO/Blk	600	10	600V/30A	N/A	4	9705-88706	RTBA3L-WW-B16F
Blunt Ends	35'	16/3	SO/Blk	600	10	600V/30A	N/A	4	9706-03132	RTBA3L-WW-B16H
Blunt Ends	50'	16/3	SO/Blk	600	10	600V/30A	N/A	4	9705-88707	RTBA3L-WW-B16K
Blunt Ends	30'	12/3	SO/Blk	600	20	600V/30A	N/A	4	9705-88708	RTBB3L-WW-B12G
Yellow Powder Coated Cord Reels, Safety Yellow Outlet Box - NEMA 2 Indoor Use										
2-15A Duplex Outlet Box	25'	16/3	SJ/Blk	125	10	600V/30A	5-15P	2	9705-88709	RTBA3L-WDD515-J16F
2-15A Duplex Outlet Box	35'	16/3	SJ/Blk	125	10	600V/30A	5-15P	2	9705-88710	RTBA3L-WDD515-J16H
2-15A Duplex Outlet Box	50'	16/3	SJ/Blk	125	10	600V/30A	5-15P	2	9705-88711	RTBA3L-WDD515-J16K
2-15A Duplex Outlet Box	50'	14/3	SJ/Blk	125	15	600V/30A	5-15P	2	9705-88712	RTBA3L-WDD515-J14K
Blunt End	25'	12/3	SJ/Blk	125	20	600V/30A	5-20P	2	9705-88713	RTBB3L-WW-J12F
Blunt End	50'	12/3	SJ/Blk	125	20	600V/30A	5-20P	2	9705-88714	RTBB3L-WW-J12K
1-20A GFI Duplex Outlet Box	25'	12/3	SJ/Blk	125	20	600V/30A	5-20P	2	9705-88715	RTBB3L-WGB520-J12F
1-20A GFI Duplex Outlet Box	50'	12/3	SJ/Blk	125	20	600V/30A	5-20P	2	9705-88716	RTBB3L-WGB520-J12K
2-20A Duplex Outlet Box	25'	12/3	SJ/Blk	125	20	600V/30A	5-20P	2	9705-88717	RTBB3L-WDD520-J12F
2-20A Duplex Outlet Box	50'	12/3	SJ/Blk	125	20	600V/30A	5-20P	2	9705-88718	RTBB3L-WDD520-J12K
White Powder Coated Reels - NEMA 4 Indoor/Outdoor Use										
Blunt End	25'	12/3	SE/Wht	600	20	600V/30A	N/A	4	9705-88719	RTBB3LW-WW-H12F
Blunt End	50'	12/3	SJ/Wht	300	20	600V/30A	N/A	4	9705-88720	RTBB3LW-WW-P12K
White Powder Coated Reels, Matte Black Outlet Box - NEMA 2 Indoor Use										
2-20A Duplex Outlet Box	25'	12/3	SE/Wht	125	20	600V/30A	5-20P	2	9705-88721	RTBB3LW-1DD520-H12F
2-20A Duplex Outlet Box	50'	12/3	SJ/Wht	125	20	600V/30A	5-20P	2	9705-88722	RTBB3LW-1DD520-P12K
Accessories										
Pivot Base, 345° Rotation									9705-88723	RTBF-PVB

Custom configuration is available, call Altec for more information.



KH INDUSTRIES
PROVIDING POWERFUL SOLUTIONS FOR OVER 60 YEARS



REELTUFF™ INDUSTRIAL GRADE RETRACTABLE CORD REELS

RTF SERIES, 600V/35A RATED SLIP RING, UL LISTED



RTF REELS ARE RATED NEMA 4X FOR CORROSION RESISTANCE AND FEATURE ALL STEEL CONSTRUCTION.

DESIGNED FOR INDOOR OR OUTDOOR APPLICATIONS, INCLUDING UTILITY MAINTENANCE TRUCKS, CRANES OR HOISTS, OR ENGINE BLOCK HEATER STATIONS.

600-VOLT/35-AMP RATED SLIP RING

ALL STEEL CONSTRUCTION, INCLUDING MOUNTING BASE ADJUSTABLE CABLE GUIDE, BALL STOP, AND RATCHET

RATCHET CAN BE ENGAGED (POSITIVE LOCK) OR DISENGAGED (CONSTANT TENSION) AS NEEDED

BLUNT CUT CABLE ON FEEDER AND POWER ENDS FOR DIRECT HARD WIRING

MOUNT ON OPTIONAL PIVOT BASE FOR 345 DEGREE ROTATION

CORROSION RESISTANT YELLOW POWDER COAT FINISH

4' FEEDER CORD INCLUDED

Cord Length	Gauge/ Conductor	Cord Type	Slip Ring Rating	Max Amps	Altec	Model #
All RTF Reels are Yellow Powder Coated and NEMA 4X Rated for Indoor, Outdoor Use, including Corrosive Locations						
30'	16/3	SOOW	600V/35A	10	9705-88724	RTFD3L-WW-B16G
30'	14/3	SOOW	600V/35A	15	9705-88725	RTFD3L-WW-B14G
30'	12/3	SOOW	600V/35A	20	9705-88726	RTFD3L-WW-B12G
30'	10/3	SOOW	600V/35A	25	9705-88727	RTFD3L-WW-B10G
50'	16/3	SOOW	600V/35A	10	9705-88728	RTFD3L-WW-B16K
50'	12/3	SOOW	600V/35A	20	9705-88729	RTFH3L-WW-B12K
50'	10/3	SOOW	600V/35A	10	9705-88730	RTFH3L-WW-B10K
70'	16/3	SOOW	600V/35A	10	9705-88731	RTFB3L-WW-B16O
70'	14/3	SOOW	600V/35A	15	9705-88732	RTFJ3L-WW-B14O
70'	12/3	SOOW	600V/35A	20	9705-88733	RTFQ3L-WW-B12O
RTF Reels, 4 Conductors						
30'	16/4	SOOW	600V/35A	8	9705-88734	RTFD4L-WW-B16G
30'	14/4	SOOW	600V/35A	12	9705-88735	RTFD4L-WW-B14G
30'	12/4	SOOW	600V/35A	16	9705-88736	RTFD4L-WW-B12G
30'	10/4	SOOW	600V/35A	20	9705-88737	RTFC4L-WW-B10G
50'	16/4	SOOW	600V/35A	8	9705-88738	RTFD4L-WW-B16K
50'	12/4	SOOW	600V/35A	16	9705-88739	RTFH4L-WW-B12K
50'	10/4	SOOW	600V/35A	20	9705-88740	RTFP4L-WW-B10K
70'	16/4	SOOW	600V/35A	8	9705-88741	RTFA4L-WW-B16O
70'	14/4	SOOW	600V/35A	16	9705-88742	RTFQ4L-WW-B14O
60'	12/4	SOOW	600V/35A	20	9705-88743	RTFP4L-WW-B12M
Accessories						
Pivot Base, 345° Rotation					9705-88723	RTBF-PVB

Custom configuration is available, call Altec for more information.

CORD CADDIES

PORTABLE, TANGLE FREE POWER IN A RUGGED AND FLEXIBLE DESIGN

120 VOLT INPUT WITH EITHER 15-AMP OR 20-AMP DUAL DUPLEX OUTPUT IN A DURABLE DESIGN WHICH INCLUDES YELLOW POWDER COATED STEEL END PLATES AND SOLID STEEL FRAME. CORD CADDY CAN BE USED HORIZONTALLY OR VERTICALLY.



FULLY GROUNDED ASSEMBLY
DURABLE SOLID STEEL FRAME
DUAL DUPLEX RECEPTACLES

NO COLLECTOR RINGS, BRUSHES, OR SLIP RINGS
GROUND FAULT CIRCUIT PROTECTION (OPTIONAL)
RECEPTACLES/PLUG: NEMA 5-15 OR NEMA 5-20



Cord Length	Cord Gauge/ Conductor/Type	Amps	NEMA Configuration	Altec	Model #
No Cable	No Cable	15-Amps	(4) N515 GFCI	9705-88744	CCG-515-A
200'	14/3 Blk SOOW	15-Amps	(4) N515 GFCI	9705-88745	CCG-515-B14Y
200'	14/3 Yel SOOW	15-Amps	(4) N515	9705-88746	CCN-515-Y14Y
No Cable	No Cable	20-Amps	(4) N520 GFCI	9705-88747	CCG-520-A
100'	12/3 Yel SOOW	20-Amps	(4) N520 GFCI	9705-88748	CCG-520-Y12U
125'	12/3 Yel SOOW	20-Amps	(4) N520 GFCI	9705-88749	CCG-520-Y12V
125'	12/3 Blk SOOW	20-Amps	(4) N520	9705-88750	CCN-520-B12V



KH INDUSTRIES
PROVIDING POWERFUL SOLUTIONS FOR OVER 60 YEARS



HANNAY REELS & ACCESSORIES

TRUCK ACCESSORIES

USA: 1-877-GO ALTEC
(1-877-462-5832)

www.alteconnect.com

Hannay GCR 10-17-19 Spring Rewind Grounding Reel

- Independently tested to 43 kVA for 30 cycles
- Helps meet OSHA requirements for vehicle grounding
- Offers manual rewind with hand crank permanently attached to disc
- Internal rotary device

ALTEC P/N	BASE MODEL	CABLE CAPACITY OF REEL			APPROX. WEIGHT	
		Cable Size	ft.	m	lb.	kg.
7052-01178*	GCR10-17-19	#2	150	45.7	30	13.6
		1/0	90	27.4	30	13.6
		2/0	90	27.4	30	13.6

* Does not include cable

Hannay GC 10-17-19 Manual Rewind Grounding Reel

- Storage only
- Manual rewind with hand crank permanently attached to disc

ALTEC P/N	BASE MODEL	CABLE CAPACITY OF REEL			APPROX. WEIGHT	
		Cable Size	ft.	m	lb.	kg.
9703-22718*	GC10-17-19	#2	150	45.7	28	12.7
		1/0	90	27.4	28	12.7
		2/0	90	27.4	28	12.7

* Does not include cable



Hannay SGCR 10-17-19 Spring Rewind Grounding Reel

- Independently tested to 43 kVA for 30 cycles
- Helps meet OSHA requirements for vehicle grounding
- Fast, convenient, automatic spring rewind
- Ratchet mechanism locks the reel
- Built-in cable hoop
- Internal rotary device

ALTEC P/N	BASE MODEL	CABLE CAPACITY OF REEL			APPROX. WEIGHT	
		Cable Size	ft.	m	lb.	kg.
9701-33048*	SGCR10-17-19	#2	75	22.9	43	19.5
		1/0	75	22.9	43	19.5
		2/0	65	19.8	43	19.5

* Does not include cable

ALTEC P/N	BASE MODEL	REEL DIMENSIONS (INCHES)									
		A	B	C	D	E ¹	F ¹	G	H	X	Y
7052-01178*	GCR10-17-19	9	6	10.5	15	16.5	10.5	17.19	8.94	-	-
9703-22718*	GC10-17-19	9	6	10.5	15	16.5	10.5	17.19	8.94	-	-
9701-33048*	SGCR10-17-19	9	5.5	10.5	15	16.5	10.12	17.19	8.94	-	-

* Does not include cable

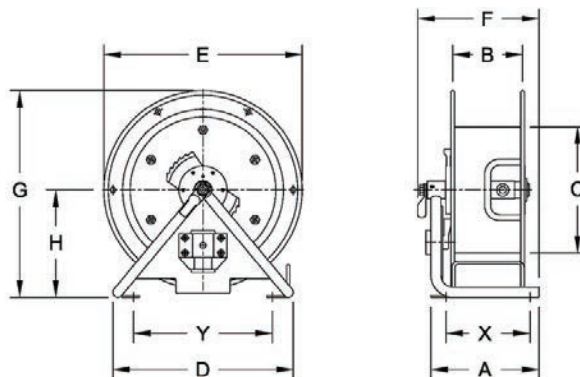



PAYOUT REEL FOR COILS OF GUY WIRE



- Specifically designed for line workers
- Manufactured of **no-rust, high-grade aluminum**
- Rugged and **lightweight** (Wall mount model only 24 lbs.)
- **Easy to load** 250 ft and 500 ft coils of 3/8, 5/16 guy wire and also 250 ft. coils of 7/16
- **Floor mount or wall mount model** for flexible installation anywhere in truck
- 5 removable brackets each of which includes 4 notches that **adjust to various coil outer diameters**
- Sealed bearing allows **smooth rotating payout or re-wind** of guy strand



BENEFITS

Safer handling of guy wire

Minimizes injuries

Eliminates spiral twist when paying out strand

Compact and efficient coil storage

REELS:

P/N 8180-00620 Wall Mount: 30" Wide x 30" Tall x 7" Deep; Weight: 24 lbs.

P/N 9700-65320 Floor Mount: 30" Wide x 32" Tall x 9" Deep; Weight: 40 lbs.



FLOOR MOUNT



WALL MOUNT

Heavy Duty Hose Reels

- Steel construction for long life
- Durable epoxy powder-coat finish
- Containerized mainspring for safe handling
- Weathertight design
- Adjustable guide arm with four-roller guide
- Brass & stainless steel fluid path and nitrile seals
- Ratchet lock
- Reel includes hose

P/N	Inlet Hose Fitting (NPT)	Hose Inner Diameter (in)	Hose Length (ft)	Hose Pressure (psi)
9703-59508	DB330	3/8	30	300
9705-88865	DB350	3/8	50	300
9705-88866	DB430	1/2	30	300
9705-88867	DB450	1/2	50	300



Grounding Reels with Cable

- Provide a simple, positive means for grounding line trucks or other vehicles parked in electrically hazardous areas
- Inverse loop design, silver-plated copper contact pressure under fault conditions
- Compression terminals connect the cable to the reel and ground clamp
- A removable plastic cover encases the shafts contacts to reduce contamination

Reels with Cable

- P/N 0692-96072 Aeromotive with 5' of #2 GA Cable, 60' long
- P/N 0692-96073 Aeromotive with 5' of #1/0 GA Cable, 60' long
- P/N 0692-96074 Aeromotive with 5' of #2/0 GA Cable, 60' long
- P/N 0692-96075 Aeromotive with 5' of #2 GA Cable, 40' long
- P/N 0692-96076 Aeromotive with 5' of #1/0 GA Cable, 40' long
- P/N 0692-96077 Aeromotive with 5' of #2/0 GA Cable, 40' long
- P/N 9701-60843 Aeromotive with 5' of #4/0 GA Cable, 50' long
- P/N 8110-00580 Copper U-Bolt (shown right)



Welding Reels

- Standard models cover the four most popular wire sizes
- Containerized mainspring for safe handling
- Weathertight design
- Adjustable guide arm with four-roller guide
- Permanent lubrication
- Ratchet lock
- Reel includes cable

Altec	Molex	AWG Size	Length (ft)	Amp Rating
9705-88868	ERA4250	2	50	250
9705-88869	ERA4150	1	50	250
9705-88870	ERA4040	1/0	40	350
9705-88871	ERA4940	2/0	40	375

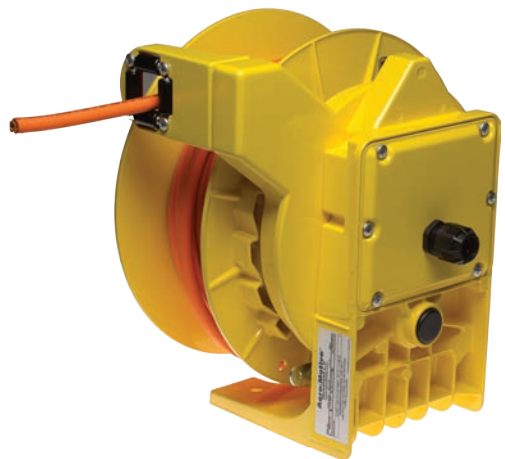



Hand Wind Reels

- This rugged hand wind reel is designed for heavy duty industrial storage applications, such as storing extension cords, power cables, and hoses
- Center cavity allows convenient access to the end of the conductor
- Capacity: for example, the unit can hold up to 100' of 3-conductor type SO cable, size #12 AWG
- Unit is UL listed

P/N 9700-64003 932D123

Woodhead

Woodhead Power Cord Reels

- Designed for optimum performance and a long service life, this durable cord reel is perfect for a wide variety of applications including hoists, electric tools and moving equipment
- The unit is factory assembled and includes Type SO or W cable
- Containerized main spring assures safety and easy handling
- Features include an adjustable cable guide with anti-cable "lock out", and a modular collector ring; Cable included



P/N	Rated Amps.	AWG Size	No. Conductors	Length	Weight
0683-70035	353D	18 12	3	25'	38 lbs.
0683-70154	435D	18 12	3	50'	49 lbs.
9703-46660*	105101303	18 14	3	70'	30 lbs.

* Cable is not included with this model

Watertite Cordsets

- Multiple seal plug/connector interface keeps out contaminants, resists vapor and water from high-pressure wash down to 1000 psi
- Plug & connector made of rubber
- Cord is SOW rubber jacket rated to 600V
- Face screws are stainless steel
- Blades & contacts are nickel plated brass
- NEMA rating 4X, 6P
- Molded Y & W version provide additional outlets

Altec	Molex	AWG Size	Length (ft)	Number of Outlets
9705-88872	14W47A163	16/3	25	1
9705-88873	14W47B163	16/3	50	1
9705-88874	14W47D163	16/3	100	1
9705-88875	14W47A143	14/3	25	1
9705-88876	14W47B143	14/3	50	1
9705-88877	14W47D143	14/3	100	1
9705-88878	14W47-Y	12/3	3	2
9705-88879	14W47-W	12/3	3	3

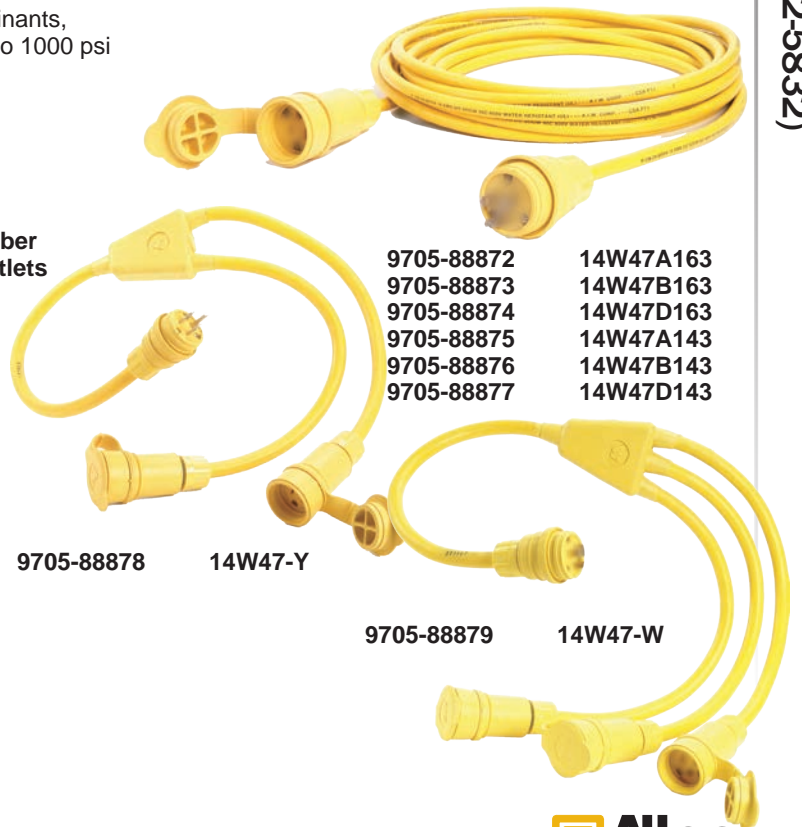

9705-88878

14W47-Y

9705-88879

14W47-W

9705-88872
9705-88873
9705-88874
9705-88875
9705-88876
9705-88877

14W47A163
14W47B163
14W47D163
14W47A143
14W47B143
14W47D143

REELS & ACCESSORIES

TRUCK ACCESSORIES

USA: 1-877-GO ALTEC
(1-877-462-5832)

www.alteconnect.com

Hydraulic Reels & Hydraulic Hoses

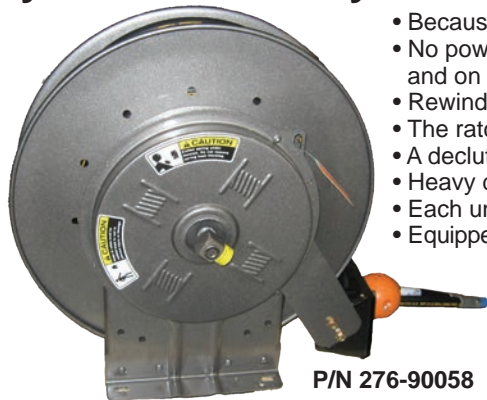

P/N 276-90058

- Because rewind power is self-contained, spring rewind reels are extremely versatile
- No power connections are required and the reels may be installed in almost any position and on all types of equipment
- Rewinds hose automatically when hose is pulled to release the ratchet
- The ratchet provides interval locking or may be detached for constant tension operation
- A declutching hub arbor prevents damage to the spring from reverse winding
- Heavy duty spring operates through thousands of cycles without power loss
- Each unit is equipped with rollers to protect the hose as it extends and retracts from the reel
- Equipped with two swivel joints, allowing use of two hoses simultaneously

Reels

- P/N 276-90002 Reel holds 50' of 1/2" hose and 65' of 1/4" - Hose not included
 P/N 276-90058 Reel holds 50' of 3/8" and 1/2" hoses - Hose and ball stop included

Replacement Hose Assembly

- P/N 9700-89626 Replacement Hose Assembly for P/N 276-90058

Reel Hose

- P/N 0271-39058 25' of 1/2" hose
 P/N 0271-39003 50' of 1/2" hose
 P/N 0271-29007 25' of 3/8" hose
 P/N 0271-29027 50' of 3/8" hose



P/N 276-90002



P/N 9703-64609

LD Payout Reel

- Designed for picking up wire cable in neat coils in addition to paying out
- Unit expands and contracts and is designed to work in any position in-between.
- Unit may be used alone or in a combination to pay in/out numerous coils. The reel is simply attached to any compatible base
- Loading and unloading is easily accomplished by folding up/down the spring-loaded fingers located on the outside of the reel
- Rope brake drags in one direction to ensure ease of rewinding and which aids in evenly paying out wire or cable
- May be mounted on your truck using very limited space
- Made of both high-strength steel and heat-treated aluminum
- Max Paddle ID: 21"; Min. Paddle ID: 14"; Paddle Width: 12";
- Unit Height: 39"; Unit Width: 20"; Weight: 46 lbs.

P/N 9703-64609 132513

Buckingham Reel Stand

- No loose parts or unnecessary metal bands
- Handles full coils with ease while storing partially used ones safely

- P/N 0692-99207 6150 6 1/2" depth x 30" width; weighs only 10 lbs.
 P/N 9700-95171 61501 8" depth x 36" width; weighs only 12 lbs.



P/N 692-99207

Hydraulic Reel Ball Swivel



- 1/2" swivel joint
- 90° - male to female
- Made from steel
- Rated to 3000 psi

P/N 276-99034

Hydraulic Reel Ball Stop



- Recommended with spring rewind reels and 4-way roller assemblies
- Each stop is easily assembled with the fasteners provided, without any special tools
- Two-piece molded plastic spheres, custom drilled to the size you specify

- P/N 276-90011 For dual 3/4" hose
 P/N 276-90051 For 3/8" and 1/2" hose



REELS & ACCESSORIES

Grounding Reels Without Cable

- Provide a simple, positive means for grounding line trucks or other vehicles parked in electrically hazardous areas
- Inverse loop design, silver-plated copper contact pressure under fault conditions
- Compression terminals connect the cable to the reel and ground clamp
- A removable plastic cover encases the shafts contacts to reduce contamination

Reels without Cable

P/N 0692-96069 Kearney for #2 GA Cable
P/N 0692-96070 Kearney for #1/0 GA Cable
P/N 0692-96071 Kearney for #2/0 GA Cable

**NOTE: Reels DO NOT
Include Cable**

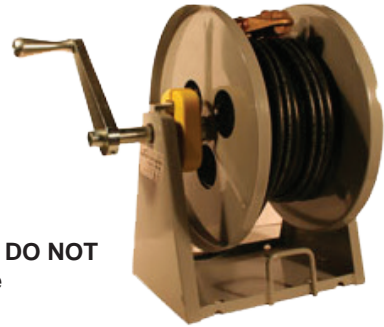

Collapsible Power Reel

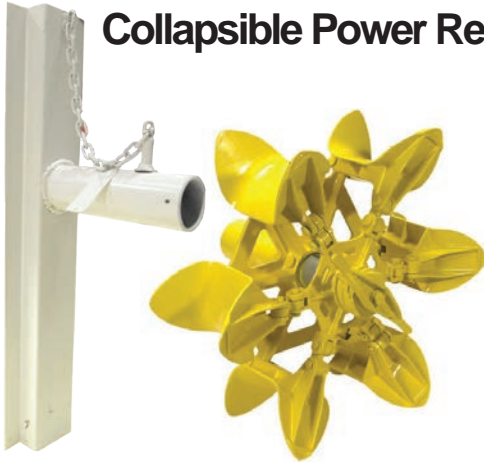

- Ideal for placing or removing aerial cable, taking down wire, or pulling winch line into conduits
- Reel may be used as a pulling capstan for pulling in poly rope or tape
- Has a capacity of 1,600' of 1/4" wire rope with a maximum allowable pull of 3500 lbs. Bare Drum; stores a 200 lb. coil of wire
- Mounts on the end of any 2 7/16" winch drum extension shaft, bayonet, or pin type mount unit
- Spindle has a fixed spider and sliding spider; six movable rim segments attached
- A half turn of the handle collapses all six moveable segments, allowing quick removal of coils
- Reel O.D.: 28" (expanded), 18 3/4" (collapsed); ID: 20"

P/N 9706-19921

Power Reel

P/N 3194-00201

Mounting Bracket

P/N 415-01079

Extension Shaft

NOTE: Do not use to store mule tape

Bolt-On Reel (4 Reel Capacity)

- Custom-fabricated wire reel with crank handle
- Reel accommodates up to 4 reels at one time
- 14" Length x 14" Tall
- Bolt-on Assembly

P/N 9706-04053 Altec White

P/N 9703-27597 Omaha Orange

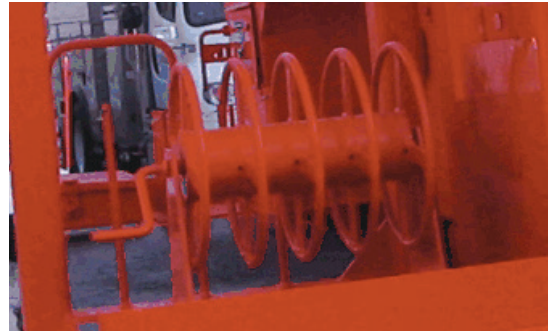

Bashlin Adjustable Payout Reel

- 32" Long x 10" Wide x 33" Tall
- Lightweight-only 54 lbs.
- Fits a wide range of coil sizes with an easy center adjustment
- Sturdy welded frame construction for years of service
- Easily change a coil by removing the out-side wheel.
- The versatile light-weight/rugged design allows it to be either bolted to a vehicle, or temporarily secured to a pole

P/N 9706-19935

TRUCK ACCESSORIES

**USA: 1-877-GO ALTEC
(1-877-462-5832)**

www.alteconnect.com



HASTINGS

A WORLDWIDE SUPPLIER OF
Hot Line Tools & Equipment

TRUCK ACCESSORIES

USA: 1-877-GO ALTEC
(1-877-462-5832)

www.alteconnect.com

Hastings Truck Safety Barricade Kit

- Barricade can be installed, positioned, or raised, and removed in minutes. Just drop in place in pre-located permanently attached steel brackets
- Fiberglass arm is easily positioned to adjust barricade for proper height above the ground and to compensate for parking on uneven terrain
- Design allows fiberglass arm to be quickly located in eight different positions
- Arm can be moved to "vertical travel position" when movement of truck for a short distance is required
- All metal components (except steel adapters attached to truck) are stainless steel or aluminum, to reduce corrosion problems from salt atmosphere and winter operations



- P/N 8140-00372 6795 Truck Safety Barrier Kit with 4' Arms
- P/N 9000-99601 6796 Truck Safety Barrier Kit with 6' Arms
- P/N 8140-00371 6798-1 Universal Weld on Adapter
- P/N 8140-00373 6795-1 4' Fiberglass Arm with Bracket
- P/N 9000-99602 6496-1 6' Fiberglass Arm with Bracket

Hastings Truck Barricade Arm

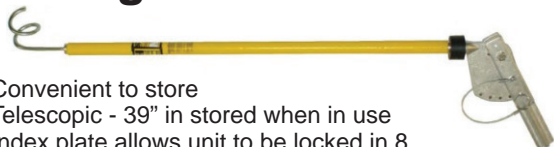

- Convenient to store
- Telescopic - 39" in stored when in use
- Index plate allows unit to be locked in 8 different positions
- Features rubber cushion base that helps prevent breakage in high traffic areas

P/N 7160-30543 6929

Hastings Sliding Barricade Bar

- 51" to 85"
- Telescopic barricade
- High visibility yellow and black
- Ideal visual barricade

P/N 9701-06915 6850

Hastings Tubular Storage Kit

CANISTER KITS

- Canister kits are manufactured to fit common sizes of schedule 30/40 PVC 4" and 6" pipe, and 6" drain pipe. All kits are designed for easy assembly

ALUMINUM LID ASSEMBLY AND END CAPS

- Kit consists of lid assembly, end cap, and 2 mounting brackets, adhesive kit, required mounting hardware, and instructions. The same kit is available with premium brackets in place of the standard brackets
- Latch pin is a captive component and is easily operated by a pull or push motion
- Latch pin hinge is stainless steel
- Water and dust proof seal

PVC LID ASSEMBLY AND END CAPS

- Kit consists of PVC lid, end cap, 2 mounting brackets, PVC glue, required mounting hardware, and instructions. The same kit is available with premium brackets in place of the standard brackets
- Stainless steel latching lever is spring-loaded and easy to operate
- Water and dust proof seal



Standard Aluminum Kit



Standard PVC Kit



Premium Aluminum Kit



Premium PVC Kit

Part Number	Hastings	Size	Description	Fits
P/N 692-98147	01-3200	4"	Standard Kit	4 1/2" O.D. Schedule 30/40 PVC (Aluminum Lid Assembly, End Cap)
P/N 7053-01209	01-3300	6"	Standard Kit	6 1/4" O.D. PVC Drain Pipe (Aluminum Lid Assembly, End Cap)
P/N 692-98074	01-3400	6"	Standard Kit	6 5/8" O.D. Schedule 30/40 PVC (Aluminum Lid Assembly, End Cap)
P/N 9700-66583	01-3500	4"	Standard PVC Kit	4 1/2" O.D. Schedule 30/40 PVC (PVC Lid, End Cap)
P/N 692-98276	01-3600	6"	Standard PVC Kit	6 5/8" O.D. Schedule 30/40 PVC (PVC Lid, End Cap)
P/N 9700-73541	01-3200-P	4"	Premium Kit	4 1/2" O.D. Schedule 30/40 PVC (Aluminum Lid Assembly, End Cap)
P/N 9700-73542	01-3300-P	6"	Premium Kit	6 1/4" O.D. PVC Drain Pipe (Aluminum Lid Assembly, End Cap)
P/N 0692-98074	01-3400-P	6"	Premium Kit	6 5/8" O.D. Schedule 30/40 PVC (Aluminum Lid Assembly, End Cap)
P/N 9701-97806	01-3500-P	4"	Premium PVC Kit	4 1/2" O.D. Schedule 30/40 PVC (PVC Lid, End Cap)
P/N 9701-97807	01-3600-P	6"	Premium PVC Kit	6 5/8" O.D. Schedule 30/40 PVC (PVC Lid, End Cap)
P/N 8786-60060*	Blaylock TCK8	8" Kit		

PRIORITYSTART!™ PROMAX

- Designed to prevent dead batteries and damaged alternators
- For all 12-volt applications
- Features only 3 connections; installs in minutes
- Will not disconnect the battery when the engine is running (by sensing electrical "noise" (30 mill volts))
- If a vehicle alternator or alternator belt fails, the "engine running" circuitry recognizes the condition and prevents disconnection at the 11.7-volt threshold, allowing the vehicle to continue on the reserve capacity of the battery
- Tested and certified to ISO, USCG and SAE standards
- The unit can handle up to 1000 Starting Amps; the continuous current rating is at 250 amps
- One universal design fits top-post or side-terminal batteries
- Contains upgraded circuitry protecting users from interference caused by complex computer systems found in all newer vehicles as well as aftermarket add-ons
- By using the PriorityStart! ProMax you will utilize the maximum service life of your battery and alternator. If a battery is allowed to run down--or jump-started--even once, this may damage a large portion of its operating service

STOPS DEAD BATTERIES!

3 EASY CONNECTIONS



Attaches in Minutes - NO Hard Wiring Required



How PriorityStart!™ ProMax Works:

If the battery voltage drops below 11.7 volts *for any reason*, it will automatically disconnect the entire electrical load from the battery (This might occur when accidental drain has occurred (e.g. lights or any other accessory left on) or perhaps the vehicle has been sitting for several days' in-between uses). Any aftermarket devices will also be automatically disconnected from the battery. When the load is disconnected, the battery recovers to its previous level, leaving starting power. The battery automatically reconnects when the user simply draws a load of 0.2mV directly to the battery. The unit will read this "request" and allow power to be restored. The load may be provided by using specific accessories on your vehicle such as activating headlights or pressing brake pedal.

P/N 9702-44736

TRUCK BARRICADE KITS

Hastings Truck Barricade Kit for Altec Units

- **Made exclusively for Altec Units**
- Barrier can be installed, positioned, or raised for moving truck and removed in minutes. Just drop in place in pre-located permanently attached steel brackets
- Fiberglass arm is easily positioned to adjust barricade for proper height above the ground and to compensate for parking on uneven terrain
- Arm can be moved to vertical travel position when short distance movement of a truck is required
- All metal components (except for steel adapters for attaching to trucks) are stainless steel or aluminum, to reduce corrosion problems from salt atmosphere and winter operations
- **Unique design of sector allows fiberglass arm to be quickly locked in eight different positions from 30 degrees above horizontal to 22 1/2" below horizontal in 7 1/2 degree increments through the use of a stainless steel quick release pin**



P/N 9702-91325 Made Exclusively For Altec Units

Includes: (4) 9701-18724 EX3-729 arms
(2) 7160-30542 6800 Danger Signs - Red,
(1) 7160-30546 3649 150' - 1/4" Polypropylene Rope (Yellow)

A.B. Chance / Hubbell Truck Safety Barricade Kit



- This kit keeps workers and onlookers away from the truck when the truck is being used in proximity to energized conductors
- Six rods, of bright orange Epoxirod®, provide a 6' air space around the entire perimeter of the truck
- The safety barricade also includes six pieces of 3" long steel tubing (to be welded to truck by the customer) to hold the barricade rods, 150' of yellow rope and a canvas storage bag
- The entire kit requires less storage than traffic cones and can be quickly installed and removed at each job site

P/N 9700-28250 Hubbell T3060006

163

Altec Supply

TRUCK ACCESSORIES

USA: 1-877-GO ALTEC
(1-877-462-5832)

www.alteconnect.com

MISCELLANEOUS TRUCK ACCESSORIES

TRUCK ACCESSORIES

USA: 1-877-GO ALTEC
(1-877-462-5832)

www.alteconnect.com

Wheel Check Locking Tab Wheel Lug Indicators

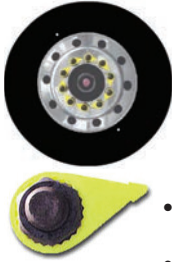

- Provides a simple, visual means of confirming proper wheel torque in seconds
- Reduce your risk of wheel detachment accidents (Protect the public, help prevent property and load damage)
- Lower your maintenance costs by eliminating unnecessary re-torquing
- Quickly identify a hot wheel possibly caused by bearing failure or brake drag
- Decrease equipment downtime
- Facilitates official roadside inspections
- Clearly visible at night and in rain, snow, muddy conditions
- Easy to install and costs only a few dollars per wheel
- Pays for itself in just one unnecessary re-torque procedure

P/N 660-02029

Mud Flaps



- Prevents your utility vehicles from kicking up damaging stones, dust and other road debris
- Constructed of rubber for long life
- Mud flaps are black, with Altec's logo and name printed in white

- P/N 9704-92022 24" x 24" with logo
 P/N 0660-02001 24" x 24" without logo
 P/N 9704-93016 24" x 30" with logo

Cargo Net

- Mounting this tough cargo net on the back of the truck helps catch items that become dislodged in the cargo area

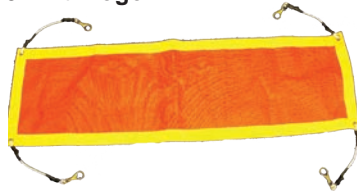

- Dimensions: 59" x 18"; made from a high visibility material

P/N 9000-11800

Safety Lightsticks

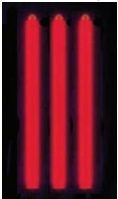

- Provide long distance illumination
- Visible in fog, rain, or snow
- Waterproof and windproof
- Non-toxic and non-flammable
- Easy Snaplight[®] activation

P/N 9700-20801 6" Snaplight[®] 30-minute Lightsticks, White
 P/N 9700-20800 10" Safety Glow lightsticks w/stand, Red

Safety Cones



- Rugged, brightly colored safety cones
- Designed for many years of outside use
- Cones are constructed of day-glow red/orange PVC with two reflective collars
- 18", 28", and 36" tall cones available

P/N 9000-00215 18" Cone Base 11" x 11"
 P/N 9000-00216 28" Cone Base 14" x 14"
 P/N 9000-3004236" Cone Base 14.5" x 14.5"



Platform Rest Tube



- This tube acts as an absorber while the truck is in motion
- Positioned under the bucket, these platform rests will help keep your platform in newer condition

P/N 704-20353 24" Long
 P/N 704-20463 36" Long
 P/N 704-21071 42" Long

LED Compartment Lighting



- Super bright, efficient white lighting
- Each section is 12" long with 24 LEDs
- Draws 80% fewer amps than incandescents
- Rated average working life: 100,000 hours
- LEDs are safe to touch and exceed NFPA standards
- Operate in full voltage range from

9.3 to 14 VDC

- Withstand road vibration and shock better than halogens
- Includes instructions, screws, male and female pigtail harnesses

P/N 9705-16703 24" LED Strip with 1" on Each End
 P/N 9705-16702 36" LED Strip with 1" on Each End
 P/N 9705-16701 48" LED Strip with 1" on Each End

18" & 28" Pack N' Pop Cones & Tote



- 13.5" x 13.5" x 8" plastic tote
- Durable, bright orange, flexible nylon
- Rubber base grips the road for stability
- Meets MUTCD standards
- Collapses flat for easy storage
- Internal light endures over 100,000 flashes or 36 hours of steady burn

P/N 9700-89530 Qty of 4 - 18" Cones/Nylon Bag Set
 P/N 9700-89527 Qty of 5 - 28" Cones/Nylon Bag Set
 * Cones are also available individually

Emergency Warning Triangle 3pk



- Weighted base anchors the triangles
- No tools required for set-up
- Kit includes 3 triangles that fold flat
- Includes a compact plastic storage container

P/N 660-21045

Manual Pouch

- Flannel coated polyester with bound edges
- Feature two back grommets for mounting to a truck cab

P/N 99-60038



MISCELLANEOUS TRUCK ACCESSORIES

ECO>ABSORB

- Environmentally safe and 100% all natural, non-toxic absorbent, 100% safe to use around humans, animals, and safe for the environment
- Oil spills, chemical spills, hazmat spills, food and beverage spills and all other commercial and residential spills are no match for this light-weight super absorbent.
- Completely cleans any spill leaving no residue, stain, or odor behind
- Using ECO>ABSORB satisfies Fat, Oil and Grease Best Management Practices.
- Can absorb all paint spills, grease, gas spills, motor oil spills, automotive fluid spills, body fluid spills plus an array of other fluids and all chemicals except hydrofluoric acid
- 100% safe to use around humans, animals, and safe for the environment
- This is a money saving and time-saving spill mitigation product, which cleans up any spill without hurting the environment in any way

P/N 9704-57313 13031-00188



Conoco Super-STA M



- Adhesive, multipurpose, extreme-pressure (EP) lithium grease with excellent extreme-pressure and antiwear properties; good oxidation resistance
- Contains a tackiness additive for improved retention, reduced leakage and resistance to water washout
- Manufactured with high quality paraffinic base oils and a lithium 12-hydroxystearate soap thickener
- Fortified with 1% molybdenum disulfide for extra protection under heavy or shock loading

P/N 99-00025 SUPER-STA M#2

Canadian Formula De-Icer



- Very effective in clearing ice, frost, and snow from windshields and mirrors
- Melts snow, frost, and ice on contact down to -60° without scraping
- Helps prevent re-freezing
- Will not harm paint, metal, plexiglass, or other surfaces found on motor vehicles, utility equipment

P/N 9700-81625

Ideal Wipes



- Pre-moistened wipes that require no water, cleans dirt, grease, glue, and grime
- Durable fabric scrubs without tearing
- Infused with natural hand moisturizers, vitamin E
- 82 wipes per can

P/N 9701-84350 38-500

Clean-N-Glaze



- Contains chemical cleaners and very fine polishing abrasives plus superior glazing materials
- Formulated to thoroughly clean and produce a durable, brilliant finish on all gel-coated or metal surfaces

P/N 0041-90002 1 Qt.

Anti-Skid Surfacing Material

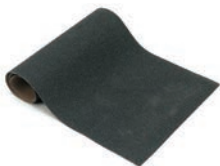

- The sure traction provided by this anti-skid tape prevents slipping and falling on wet or slick floors or stairs
- Tape surface coated with thousands of particles of durable aluminum oxide grit
- No extra edge sealing is necessary

- Rugged tape is an adhesive-backed plastic tape material
- Easy installation - just peel off protective liner and press in place

P/N 0660-60009 12" wide; 60' Roll

P/N 0660-60011 6" wide; 60' Roll

P/N 0099-00043 1 Gallon Gray Non-Slip

P/N 0099-00054 1 Gallon Black Non-Slip



Gear Shield



- Made for all types of open gears
- Designed for adverse conditions where gears are exposed to abrasive conditions such as quarry and mining operations
- NLGI Grade = 2
- 2000.0 SUS Viscosity at 100.0°F
- Drop Point (ASTM) = 370 °F
- Low-temp gear shield is for cold weather applications
- Anti-wear, anti-rust, anti-corrosion, anti-oxidation properties
- Thickener & grease type = lithium

• Specific gravity = 0.9500 [Min], 0.9800 [Max]
P/N 99-00017

Hydraulic Return Filter



- Spin-on filter
- It is the Altec quality that makes these filters be used as replacement parts for almost every make of heavy equipment

P/N 353-30007

TRUCK ACCESSORIES

USA: 1-877-GO ALTEC
(1-877-462-5832)

www.alteconnect.com

GENERAL MACHINE PRODUCTS

TRUCK ACCESSORIES

USA: 1-877-GO ALTEC
(1-877-462-5832)

www.alteconnect.com

Pole Trailer Light Kits



- Features compact design, secure attachments and maximum visibility
- Allow easy transport of utility poles with greater visibility while meeting DOT requirements and only

- adding minimal width to the trailer
- Frame is made from an aluminum extruded weldment with a durable bright yellow polyester powder coating
- DOT approved lights and reflectors are mounted on the back and sides
- The kit uses a Reflexite label with 3" high lettering and a standard legend
- Shock mounts provide greater bulb life and simplify bulb replacement
- The unit comes with a 40' 18 gauge S.O. trailer cord with a heavy-duty 4-way or 6-way trailer plug
- The width of the unit is minimized with up-right flags and cordage storage arms located within the outer dimensions of the frame
- Attachment to the pole is done with an over-center chain binder that uses 5' of chain and hardened steel spikes that bury in the pole when the binder is tightened

Part Number	Description	Weight
9000-70274	46" Wide; 4-way Plug	26 lbs.
9000-70276	46" Wide; 6-way Plug	26 lbs.
9000-70277	24" Wide; 4-way Plug	14 lbs.
9000-70278	24" Wide; 6-way Plug	14 lbs.
9000-26006	4-way Socket Only	2 oz.
9000-26007	6-way Socket Only	2 oz.

Fiber Optic Mid-Assist Capstan Head



- Specially designed to work with existing pulling equipment to provide faster, safer pulling of fiber optic cables
- May be used either as an end puller or a mid-assist booster puller
- Can pull rope, tape or the fiber cable itself and the large working diameters translate into good pulling speeds
- Torque limiting models limit pulling torque during fiber optic placement

- Slip range is factory set and wire locked for protection
- The 25" torque limiters can be calibrated to regulate tension within ranges of 500 - 700 lbs. or 750 - 1,000 lbs.
- The 32" torque limiter can be calibrated to regulate tension to maximum of 600 lbs.
- Mounting hub accommodates any 2 7/16" diameter shaft equipped with a bayonet or pin mount
- Feature either a 25" or 32" working diameter which gives a perfect bend radius for fiber optic cable
- Allows any reel loader, digger derrick unit to become a highly productive fiber placement unit

- P/N 9000-15472 GMP 15472 25" with 600 lb. torque limiter
- P/N 9000-15479 GMP 15479 25" with 1,000 lb. torque limiter
- P/N 9000-15470 GMP 15470 25" without torque limiter
- P/N 9000-70351 GMP 70351 32" with 600 lb. torque limiter

General Purpose Capstan Heads



- These bayonet mount capstans are available in ductile iron and aluminum for extension shaft winches
- May be used for almost any pulling application using roughly any type of material
- Will fit on any 2 7/16" diameter winch extension shaft
- Working surface is 7 1/4" diameter x 8" wide

P/N 9000-10727 GMP 10727 Aluminum 4,000 lbs. Rating

THROTTLE CONTROL SYSTEM & VOLTAGE REGULATOR

Automatic Throttle Control System



- Increases engine RPM, only while in park or neutral, in order to provide higher output of the alternator under heavy electrical loading conditions
- Auto-throttles can be used on many types of vehicles and are an excellent choice for applications

- using DC to AC inverters
- When equipped with the optional VoltGuard(R) Electronic Low Battery Voltage Actuator, the automatic throttle activates when the vehicle's voltage drops below 12.6 Vdc and returns to idle after voltage exceeds 13.2 Vdc
- Heavy Duty Automatic Throttle System consists of the solenoid/cable assembly and the control module assembly

P/N 683-70043 Inverter Throttle Control, complete

Solenoid/Cable Assembly



P/N 8110-00976 Solenoid/Cable Assembly with Chain and Tube, 12 VDC

A-Series Voltage Regulator



- A-Series Voltage Regulator, used on all A-30, A40, and A60 Models
- Also compatible with TA Series Dynamic inverter as a bypass regulator, for use when inverter has been removed

P/N 683-70053 Universal Regulator



PINTLE HOOKS

Pintle Hooks with Tethered Latch Pins

- High quality pintle hooks
- Strong, rugged, and built to last
- We offer a variety of spring and air-cushioned pintle hooks that are designed to pull a load of up to a maximum gross trailer weight of 100,000 lbs.
- These pintle hooks accept vertical loads up to 20,000 lbs.
- Tow shackles and hooks are also available



P/N 683-20160 PH-30SA51
Flange Mount with Swivel Hook
30,000 lb. max GTW

P/N 9000-99328 PH-30SB51
Under-Body Mount with Swivel Hook
30,000 lb. max GTW



Pintle Hook
P/N 7053-01443 PH-30RP51
Flange Mount with Rigid Hook
30,000 lb. max GTW



Pintle Hook
P/N 683-20006 PH-10RP41
Flange Mount with Rigid Hook
10,000 lb. max GTW



Pintle Hook
P/N 9702-81879 PH-10RP51
Flange Mount with Rigid Hook
and Tethered Lock
10,000 lb. max GTW

Ball type pintle hook
P/N 9701-85097 BH-200RN51
Combo Pintle Hook & 2" Ball Hitch



TRUCK BODY ACCESSORIES

Outrigger Pad Holders



P/N 3174-02906 Holds (1) Pad

- Keep outrigger pads secure during driving and are easily accessible
- Can be added underneath utility bodies for effortless storage of any size outrigger pad up to 18" x 18"

Wheel Chock Holders

- Designed to keep wheel chocks secure during transport and are effortless to store
- Made for mounting inside the fender panel close to the tires for easy accessibility when needed

P/N 3178-00112



Fiberglass Bumper Guide Sight Rods



- These rods provide drivers with the ability to assess where the front bumper of the truck is in relation to a close object
- Beneficial for inexperienced drivers or for maneuvering around or close to other objects
- Total assembly length is 38 7/8"
- Includes 7/16" diameter x 36"
- Yellow sight rod with a 1 7/8" threaded ferrule base

P/N 9700-95742 2 Rods & Hardware

Safety Cone Holders

Fold-down style (right)

Horizontal style (left)



- Provides easy access to cones
- **P/N 9000-80024** and **P/N 660-21028** are both flat-mount and do not include mounting brackets

P/N 9000-80024 Fixed - 12" x 12" x 19-3/4" Tall

P/N 660-21028 Fixed - 14" x 18" x 26" Tall

P/N 3172-01205 Fold-down

P/N 9700-32039 Horizontal

Bumper Sight Rods



- These rods provide drivers with the ability to assess where the front bumper of the truck is in relation to a close object
- Beneficial for inexperienced drivers or for maneuvering around or close to other objects

P/N 684-91001

TRUCK ACCESSORIES

USA: 1-877-GO ALTEC
(1-877-462-5832)

www.alteconnect.com

TRUCK BODY ACCESSORIES

TRUCK ACCESSORIES

USA: 1-877-GO ALTEC
(1-877-462-5832)

www.alteconnect.com

Cable Steps



- Altec weld-on cable steps provide workers a safe way to access various areas on the truck
- Made with grip strut tread to eliminate slippage from wet and muddy boots.
- These steps weld onto almost any body location
- Semi-flexible cables allow crossing ditches and hitting obstacles without permanent damage to the step

Single Step

P/N 3225-00103 9 1/2" x 7" x 12" *

P/N 3225-00107 12 1/2" x 7" x 7" *

P/N 9706-26254 12 1/2" x 7" x 12" *

P/N 3225-00102 17 1/2" x 7" x 12" *

Double Step

P/N 716-10069 12 1/2" x 7" (Top)*; 12 1/2" x 7" x 21 1/2" (Bottom)*

* Dimensions: width of step x depth of step x length of cable



Sahara Heater - Model VN-301



- Low watt model
- 800 watt reduced to 300 watt
- Solid steel construction
- Inrush: 13 amps reduced to 3 amps
- 5200 BTU
- 110 - 120 volts
- 6" x 5" x 5"

P/N 704-20409

Sahara Heater - Model TL-290



- 1500w reduced to 350 watt
- Solid steel construction
- Inrush: 13 amps reduced to 3 amps
- 5200 BTU
- 110 - 120 volts
- 6" x 5" x 5"
- Specifically designed for bucket trucks and aerial lifts

P/N 704-20399

Sauber Safety Swing (Breakaway) Step



- Forgives ditch-runners, indiscriminate backers, and many other trials that rigid or cable-type steps cannot
- Provides a firm, non-flexible step for operators, yet releases and swings away when the going gets rough
- Available in 7", 9", and 11" fixed heights as well as an adjustable step that allows height selection during installation
- Aluminum-bronze support with a hot-dipped galvanized step finish and stainless steel pivot rod make these safety steps impervious to the weather
- Installs easily with two fasteners in the face of your bumper or tailshelf

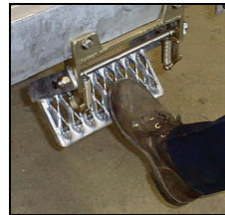

- P/N 716-10068 8467-7 7" Step with Springs
- P/N 716-10098 8467-9 9" Step with Springs
- P/N 716-10099 8467-11 11" Step with Springs
- P/N 8140-00947 8467-A 10" - 15" Adjustable Step w/Springs

120 Volt Outlet at Boom Tip



P/N 606-90005

- P/N 596-50009 features a reset button
- P/N 606-90005 is a commercial grade, gray aluminum cover plate that is weatherproof
- P/N 606-00019 features three holes and heavy duty, construction
- P/N 9703-89625 features a slim receptacle cover



P/N 606-00019



P/N 9703-89625



P/N 596-50009

- P/N 596-50009 Slim GFCI Outlet with Wallplate
- P/N 606-00019 Electronic Enclosure Box; Waterproof*
- P/N 606-90005 Electronic Enclosure Cover; Waterproof*
- P/N 9703-89625 Receptacle Cover; Waterproof*

* UL Listed "For use in wet locations"

3M™ Scotchlite™ Red & White Conspicuity DOT Tape



- Contains enough 3M™ Scotchlite™ tape to meet NHTSA requirements for marking trailer perimeter at side and rear
- Excellent visibility, even at a 45° angle
- Use on trailers up to 57' adhesive backing for easy application
- Includes (1) Roll of 2" x 75' roll of tape in an alternating

block pattern of 6" red and 6" white, (4) 2" x 12" corner strips, squeegee and instructions

• DOT certified

P/N 9703-77041

TRUCK BODY ACCESSORIES

TRUCK ACCESSORIES

USA: 1-877-GO ALTEC
(1-877-462-5832)

www.alteconnect.com

Federal Signal 2012 Series Alarms



- Available in 87 dB(A), 97 dB(A) and 102 dB(A) models with wires or stud terminals
- Alarms operate at 12/24 VDC, drawing only 0.5A
- Meets SAE J994, CE, OSHA and MSHA requirements
- Three-year product warranty

P/N 9703-92464 210238-S 87 dB(A) J994 Type D, Stud Terminals
 P/N 9703-92466 210239-S 97 dB(A) J994 Type C, Stud Terminals
 P/N 9703-92467 210240-S 102 dB(A) J994 Type F, Stud Terminals
 P/N 9703-92468 210238-W 87 dB(A) J994 Type D, Wires
 P/N 9703-92469 210239-W 97 dB(A) J994 Type C, Wires
 P/N 9703-92470 210240-W 102 dB(A) J994 Type F, Wires

Vehicle Back-Up Alarm



- Available with universal mounting and heavy gauge steel mounting brackets
- Alarms meet SAE J994 and OSHA requirements for motor vehicles and construction and material handling equipment
- 12-48 VDC, 97 dB
- 2.9" diameter x 2.4" deep
- Designed for multi-volt operation and low current draw
- The nickel-plated terminal inserts are hermetically sealed, and the housing is environmentally sealed offering superior resistance to the elements

P/N 608-70026 Federal Signal 210331

Vehicle Back-Up Alarm



- Durable, versatile vehicle back-up alarm emits a clear, strong signal that warns approaching drivers of reverse movement on the road
- Perfect for use on maintenance and utility vehicles, construction trucks and equipment trucks.
- Alarm rate is approximately 60 bpm
- Compact, made of ABS plastic housing

P/N 608-70040

Evacuator® Plus

- Solid-state design protects and resists the effects of vibration
- Alarms operate at 12/24 VDC drawing only 0.15A
- Meets SAE J994, OSHA and MSHA requirements
- Three-year product warranty



P/N 0608-70026 210331SSG 97 dB(A), SAE J994 Type C, Nickel-Plated Threaded Terminals

Fairleads



P/N 9910-05339

P/N 9910-05344

P/N 9910-04350

P/N 5275-00037

- Increases productivity
- Design enables better control and maneuvering for the placement of strand or cable
- Eliminates cable binding when the boom is working out to the side by its rotating, free-floating alignment; features hardened steel rollers for reduced wear and longevity and attaches to the existing bolt pattern on your fair lead tube

P/N 9910-05339 Standard Heavy Duty Fairlead (13" x 10") Large Single Axis (Swivel)

P/N 9910-05344 Miniature Fairlead (10" x 6") Features Latch Opening for Lasher

P/N 9910-04350 Heavy Duty Fairlead Model (16" x 10") Large Dual Axis (Rotating Axis and Swivel)

P/N 5275-00037 Heavy Duty Steel Fairlead w/Pin; 3" Gate

Cooler Truck Racks



- Attaches to your truck for mobility of beverage coolers, and is less bulky than the average rack
- The metal strips are lightweight, yet durable, and the loop holes fit a black belt fitted with a very strong metal clasp

P/N 8786-60059 Fits Coolers 685-00012, 685-00015

P/N 9700-04923 Fits Cooler 9000-00213

Cooler Truck Racks



- Made of sheet metal and features an easy to attach strap and buckle design
- Rack sizes are available to fit the 2, 5, and 10 gallon water coolers

P/N 685-00016 Fits cooler P/N 0685-00015

P/N 9700-04923 Fits cooler P/N 9000-00213

P/N 9700-47680 Replacement Strap

HINGES & RUBBER ACCESSORIES

Stainless Steel Center Hinge



- Rugged hinge can be used for boxes and doors that have 5/16" diameter hinge rods
- Dimensions: 1 1/4" high, 5/8" wide

P/N 8001-00095

Zinc Hinge



- Sturdy, heavy-duty weatherproof hinge replaces all truck body hinges exposed to weather
- Dimensions: 11/16" high, 2" wide

P/N 8001-00096

Top Door Hinge



- Sturdy corrosion-resistant hinge for truck tool cabinet doors that are hinged at the top
- Dimensions: 5/8" x 3/4" x 1/4"

P/N 8001-00908

Piano Hinge

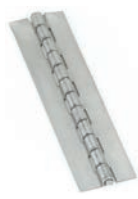

- The piano hinge is available for a wide range of opening and closing applications
- Dimensions: 1 1/2" W x 72" L open

P/N 8009-02000

Tailgate Hinge Kit



- Sturdy corrosion-resistant replacement hinge kit for truck tailgates

P/N 8001-01982

Rubber Fender



- Make sure that all the key points on your work truck are furnished and protected with these rubber fenders
- Made of high durability, UV-protected 100% gum rubber

P/N 8001-00062

Square Rubber Bumper

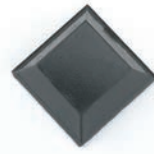

- The perfect replacement for worn out bumper guards
- This rugged square-shaped rubber bumper will provide years of protection for service vehicles
- Durable black stick-on rubber bumper features smooth non-marring surface
- Attaches easily to painted surfaces on most types of service vehicles
- Bumper dimensions: 13/16" x 13/16" x 5/16"

P/N 8001-00081

Round Rubber Cap



- Durable round rubber cap is ideal for a wide variety of applications
- Constructed of non-marring solid rubber
- Dimensions: 1 1/2" outside diameter x 7/8" deep

P/N 8001-00105

Round Rubber Bumper



- Solid round screw mounted bumper provides a full measure of protection to the vehicle
- Black bumper features a non-marring rubber surface that absorbs impact
- Dimensions: 1" wide x 1" deep

P/N 8001-00106

Rubber Door Seals

- Durable, heavy-duty material assures optimal interior insulation
- Black colored rubber seal complements all kinds of vehicle trim colors
- Seal measures 1/2" x 5/8" (sold by the foot)
- Door seals help keep the interior of the trucks warm and dry in all kinds of weather



P/N 8001-00116



P/N 8001-00136



P/N 8001-01758

Rubber Adhesive Stripping



- Sold by the foot
- Features rubber with an adhesive stripped back

P/N 8001-00146

TAIL LIGHTS - INCANDESCENT & LED

LED Tail Light



- Draws less current, resulting in increased battery & alternator life, allowing more power for other vehicle requirements
- Faster illumination offers significant safety benefit for following drivers to react quicker, resulting in an

average distance of 3' for every 10 mph

- LEDs have no filament, and are therefore extremely shock & vibration
- LED Super 44 S/T/T products 4" sealed
- Polycarbonate or acrylic lens, housing and flange
- PVC grommet, 16 gauge wire
- Designed at 14V, .03/.3 amp

P/N 684-40023

Incandescent Tail Light



- Flush mount grommets are designed for mounting in a 4 1/2" hole
- Polycarbonate or acrylic lens & housing
- ABS flange
- PVC grommet
- 16 gauge wire
- Light source: heavy duty bulb

- Designed at 13.5v, 2.16/.47 amp, 32/2 cp
- P/N 684-40017

STRIKERS, STRIKER PLATES, & SPRINGS

Striker Plate



- Replaces truck body striker plate worn from years of opening and closing doors continually in tough environmental conditions
- Dimensions: 2 7/8" L x 7/8" W

P/N 718-00381

Adjustable Striker Plate Assembly



- The 95 Series adjustable striker plate permits a perfect fit on nearly every vehicle accessory box
- Dimensions: 1" W x 3 1/2" L

P/N 8001-01964

LOCKS

Locking Door Handle



- This high quality locking handle provides convenient security for a wide variety of vehicles and equipment enclosures
- Sturdy handle and door plate constructed of rust proof steel
- Standard lock cylinder: 5" long
- Set includes two keys

P/N 8001-00004

Cylinder Lock



- Secure equipment enclosures with this rugged cylinder lock
- Cylinder is constructed of rugged rust proof metal
- Lock comes complete with 1 key

Cylinder Lock Button Plug (3/4")



- Manufactured from high quality chrome plated steel
- Extending 1/4" from outer ring are 13 sturdy teeth that provide a tight grip

P/N 8001-00588

Paddle Latch	T-Latch	Replacement Key	Lock Number
P/N 8001-00548	P/N 9000-99623	P/N 9000-00501	Lock 501CH
P/N 8001-00549	P/N 9000-99624	P/N 9000-00502	Lock 502CH
P/N 8001-00550	P/N 9000-99625	P/N 9000-00503	Lock 503CH
P/N 8001-00551	P/N 9000-99626	P/N 9000-00504	Lock 504CH
P/N 8001-00552	P/N 9000-99627	P/N 9000-00505	Lock 505CH
P/N 8001-00553	P/N 9000-99628	P/N 8001-00553	Lock 506CH
P/N 8001-00554	P/N 9000-99629	P/N 9000-00507	Lock 507CH
P/N 8001-00555	P/N 9000-99630	P/N 9000-00508	Lock 508CH
P/N 8001-00556	P/N 9000-99631	P/N 9000-00509	Lock 509CH
P/N 8001-00557	P/N 9000-99632	P/N 9000-00510	Lock 510CH
P/N 0692-92100	P/N 9000-99633	P/N 9000-00545	Lock 545CH

TRUCK ACCESSORIES

USA: 1-877-GO ALTEC
(1-877-462-5832)

www.alteconnect.com

LATCHES

Standard Paddle Door Latch



- Rugged door latch provides years of useful service
- Designed for use on Altec doors manufactured since 1995
- Smooth slide-bar action allows easy opening and closing
- Zinc plated steel construction
- Available in locking and non-locking styles

- Locking style comes with lock **P/N 692-92100** and mounting holes
- Dimensions: 4 1/4" W x 5 1/2" L x 1 1/2" deep



P/N 8001-01944 Locking
P/N 0231-80007 Non-locking

Latch w/Recessed, Folding Handle



- Sturdy latch with recessed folding handle mounts flush on door for a clean, neat appearance
- Constructed of zinc plated steel
- Dimensions: 4 3/4"W x 4 7/8"L x 2 1/2" deep
- Cylinder lock **P/N 9000-99633** included

P/N 8001-00164

Padlockable Paddle Latch



- This rugged latch allows a compartment to be secured with a padlock
- Zinc plated steel construction
- Smooth slide-bar action allows easy opening and closing
- Dimensions: 4 1/4" W x 5 1/2" L x 1 1/2" deep

P/N 8001-02342

Single Point Paddle Door Latch



- This sturdy latch is a great replacement for most Altec truck cabinet doors with smaller latches
- Stainless steel finish
- Non-locking design
- Dimensions: 3 3/4"W x 4 3/4"L x 1 1/4" deep

P/N 704-50080

Stryker Assembly



- Zinc-plated rotary latch
- Includes 2 screws and 2 washers

P/N 9701-02746

Box Door Latch



- When years of heat and sub-zero temperatures, rain, snow and dust have worn out even our tough original equipment box door locks, here is an equally well-made, sturdy, corrosion resistant replacement
- All eight parts come as a kit
- Easy to replace

P/N 8001-00002

Drawer Latch



- With years of opening and closing in the worst weather conditions, it's inevitable that one of the many drawer latches in your truck's tool cabinets will need a replacement
- This simple, sturdy lock is easy to install and gets your drawer locked tight again to protect your tools

P/N 8001-02326

Door Latch



- A sturdy, easy to install corrosion-resistant tool cabinet door latch replaces one worn out by years of use in tough conditions

P/N 8001-00056

Finger Latch



- Easy-slide zinc-plated latch replaces damaged or jammed finger latches on truck body tool cabinets

P/N 8001-00016

Rotary Paddle Latch



- Zinc-plated rotary latch
- Keyed CH545

P/N 8001-01980

Paddle Rotary Latch



- Galvanized rotary latch

P/N 9701-91068

REPLACEMENT ACCESSORIES

Galvanized Shelf Dividers 95 Series



P/N 2130-40001 Size: 14 3/4" x 2 3/8"

P/N 2130-40002 Size: 11 3/4" x 2 3/8"

P/N 2130-40003 Size: 12 3/4" x 2 3/8"

Drawer Slide



- This 14" drawer slide assures firm lid closure
- Manufactured of durable zinc plated steel
- Smooth raised tracks on inside retainer wall assures easy back and forth movement

P/N 8001-00188

Non-Locking Swivel Hook Assembly



P/N 3053-21054



P/N 3053-21001

- These rugged, swivel hooks give the user a variety of different uses for their equipment
- Hook assembly is constructed of 3/8" rod, and has a 4" throat
- The hooks are spaced 5" apart

P/N 3199-05040 Single Hook P/N 3053-21054 Four Hook
 P/N 3199-05041 Two Hook P/N 3053-21055 Five Hook
 P/N 9700-68453 Three Hook P/N 3053-21056 Six Hook



P/N 3199-05041

Limiter Assembly



P/N 3300-00901

- This rigid limiter will help keep truck body doors from opening too far
- This limiter will also help keep truck body doors closed while not in use

Flush Mount Light with Switch



P/N 684-30008

- Ideal for illuminating a cargo, cab area or as a map light
- Shock/Mount[®] protects the bulb filament
- Push button on-off switch on lens
- Chrome plated die cast housing
- Overall diameter is 5 1/4"

Recessed Tie Down



- Rugged zinc plated steel tie down features movable tie loop that recesses when not in use
- Provides a strong, secure and reliable tying surface when properly mounted to the service vehicle and other equipment
- Constructed of high quality 13 gauge zinc plated steel that resists corrosion and provides years of dependable use
- Attaches to vehicle or equipment surface
- Dimensions: 4" W x 3 3/4" L x 1" D

P/N 8001-00007

Weldnut



P/N 8001-00102

Pin Click



- Zinc plated steel pin with hinged finger ring provides strong, easy weatherproof securing of various exterior tool cabinets
- It clicks securely into place and a slight pull removes it
- Size: 1/4" dia. x 1 3/4" L

P/N 8180-00005

Universal Dome Lamp with Switch



- 6" diameter dome lamp fits most trucks
- Snap-on lens for easy bulb replacement
- Aluminum housing
- 5 1/8" polyethylene lens

P/N 8100-00001

Drip Railing



P/N 2000-00041 40" long
 P/N 2000-00042 60" long

- This railing helps prevent water from entering through the top and sides of cabinet doors
- Steel plated finish
- Available in 40" and 60" lengths

Rope Lighting



- Rope lighting luminates truck compartments for easier visibility and is mounted inside the compartment
- Available in any length (sold by the foot)

P/N 608-20003

TRUCK ACCESSORIES

USA: 1-877-GO ALTEC
 (1-877-462-5832)

www.alteconnect.com

Crane Accessories

Crane Outrigger Pads - UHMW Material

- Does not waterlog, crack, or splinter like wooden pads
- Stronger than the average wood, plywood, or cast metal outrigger pads
- Pad will return to its original shape once load is removed
- Resistant to chemicals, solvents, oils
- Radius Edge and Corner Design
- Safe and Effective Load Distribution
- Strong, yet lightweight

Altec	Sizing
9700-12780	24" x 24" x 1"
0692-93163	24" x 24" x 3"
9700-17580	30" x 30" x 1"
9700-80470	36" x 36" x 1"
9700-06218	36" x 36" x 2"
9702-40340	37" x 37" x 1"
9702-40341	37" x 37" x 2"
0692-93172	48" x 48" x 1"
9702-82833	48" x 48" x 2"
9702-63013	48" Round



Pivoting Aluminum Outrigger Shoe

- 24" Diameter
- The entire pad is non-rusting, including stainless steel fasteners
- Cast pads are the same every time, free of manufacturing variances

P/N 0791-00291 Pivoting Aluminum Outrigger Shoe

Spanner Wrench

- Tool used to adjust the rotation backlash on all Altec Cranes
- Includes 2 bolts

P/N 9702-12767 Spanner Wrench
P/N 9701-16257 Adjustment Stickers



P/N 9702-12767

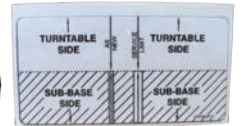

P/N 9701-16257

Pin



- Zinc-plated steel
- Shoulder-style quick-release pin
- Ring grip
- 5/8" diameter
- 5" usable length

P/N 9701-82738 98485A650 Pin

Lanyard

- Type 304 stainless steel wire rope lanyard
- Provide excellent corrosion resistance
- Sleeves and fittings are 300 series stainless steel
- Straight with loop each end
- 3/64" rope diameter
- 12" length

P/N 0234-10030 30345T36 Lanyard



LOADBLOCKS FOR MULTI-PARTING LOAD LINES

- P/N 9700-16745 Single Sheave for 9/16" Rope
- P/N 9700-16746 Double Sheave for 9/16" Rope, 4 or 5 Parting
- P/N 9700-98727 Triple Sheave for 9/16" Rope
- P/N 0791-00351 Single Sheave for 5/8" Rope, 2 or 3 Parting
- P/N 0791-00352 Double Sheave for 5/8" Rope, 4 or 5 Parting
- P/N 0791-00353 Triple Sheave for 5/8" Rope, 6 Parting

Count the number of times the load line goes either down to or up from the loadblock to determine parting number. Multiparting a load line increases the lifting capacity of the load line only, does not increase safe lifting capacity of the crane.

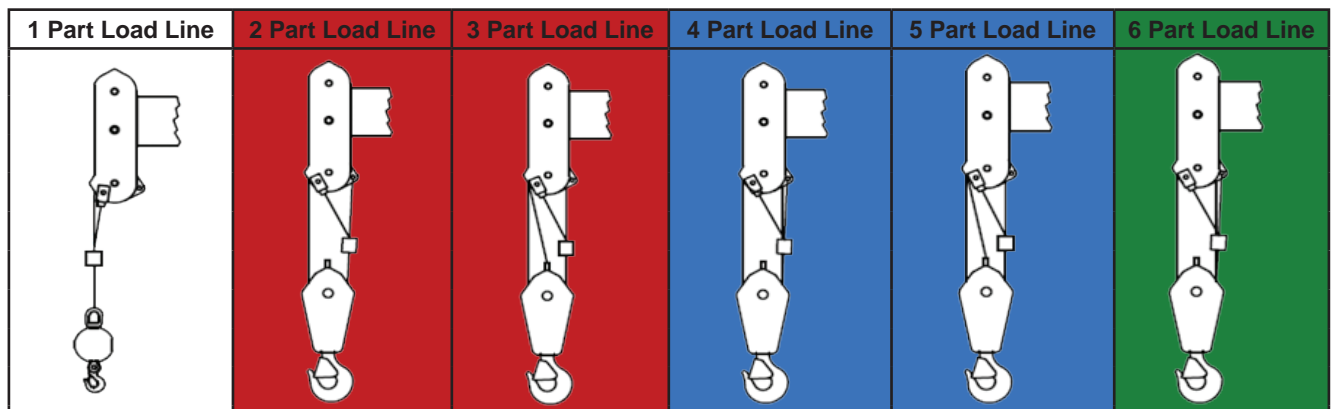

Altec Cranes:

Engineered to work hard.

And like it.



FACTORY DIRECT AND READY TO WORK, with the outstanding quality and dependability Altec is known for.



The lower winch control reduces slip/trip/fall hazards because the load hook can be disconnected without climbing to the crane controls.

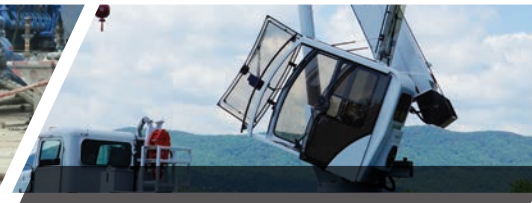

Altec's Dual Entry Cab features a 20-degree tilt which improves the operator's viewing area while reducing neck strain and associated fatigue when handling loads at height.



LMI reel is mounted at boom heel and protected by a metal cover while the A2B cable is routed through the boom, providing better reliability.

Altec.com/cranes

866.966.2969

sales@altec.com

Altec® and the Altec logo are registered trademarks of Altec Inc. in the United States and various other countries. © 2014 Altec Inc. All Rights Reserved.



STREAMLIGHT LITEBOX®



E-SPOT® LITEBOX®

- Three C4® LEDs and deep-dish parabolic reflectors produce a large spot pattern
- High: 540 Lumens, up to 7 hours; Low: 330 Lumens, up to 15 hours
- Zero-maintenance 6V, 12 Ah sealed lead-acid battery
- Fits existing Litebox® mounting racks
- IPX4 rated for weather-resistant operation
- Jumper selectable high or low setting allows higher light output or longer runtime

FL 1 STANDARD	HIGH	LOW
	540 LUMENS	330 LUMENS
	7h	15h
	469m	358m
	55,000 cd	32,000 cd

Standard System (120V AC/12V DC):

P/N 9702-46408 45851 E-Spot - Orange
P/N 9702-46412 45871 E-Spot - Yellow

Vehicle Mount:

P/N 9702-46527 45855 E-Spot 12V - Orange
P/N 9702-46530 45875 E-Spot 12V - Yellow

E-FLOOD® LITEBOX®

- Six (6) C4® LEDs
- High: 615 Lumens, up to 8 hours; Low: 330 Lumens, up to 18 hours
- Fits existing Litebox® chargers
- IPX4 Rated for weather-resistant operation
- Parabolic reflectors produce a smooth flood pattern
- Optimized electronics provide regulated intensity
- Jumper selectable high or low setting to allow higher light output or longer runtime

FL 1 STANDARD	HIGH	LOW
	615 LUMENS	330 LUMENS
	8h	18h
	126m	93m
	4000 cd	2150 cd

Standard System (120V AC/12V DC):

P/N 9702-46539 45801 E-Flood - Orange
P/N 9702-46544 45821 E-Flood - Yellow

Vehicle Mount:

P/N 9702-46557 45805 E-Flood LiteBox 12V - Orange
P/N 9702-46560 45825 E-Flood LiteBox 12V - Yellow

LITEBOX® Rechargeable Lantern



- Rechargeable, completely portable lantern
- Output: 8 watt spot = 80,000 peak beam candlepower, up to 9 hours per charge; 20 watt spot = 105,000 peak beam candlepower, up to 3.5 hours per charge
- 7.4 lbs. with 6 volt, 12 Ah sealed lead acid battery
- Standard System includes shoulder strap, AC and DC chargers, and charge rack
- Vehicle Mount Systems include truck-mountable 12 volt DC direct wire, mounting rack, and shoulder strap
- Locking device systems are available and are factory installed

Modify your existing incandescent LiteBox lanterns into LED models:

- Never replace lamps/bulbs
- LEDs are impervious to shock with a 50,000 hour lifetime
- Instructions included

The E-Spot Litebox:

- (3) C4 LEDs
- Deep-dish wide pattern parabolic reflectors produce a large spot pattern

The E-Flood Litebox:

- (6) C4 LEDs
- Wide pattern parabolic reflectors produce a smooth, uniform flood pattern



Standard System:

P/N 9702-79503 45845 Kit, E-Spot Upgrade
P/N 9702-90555 45842 Kit, E-Flood Upgrade

Standard System:

P/N 9000-21100 45117 8 Watt Spot, Yellow
P/N 9000-21101 45116 8 Watt Spot, Orange
P/N 9000-21105 45109 20 Watt Spot, Yellow
P/N 9000-21106 45110 20 Watt Spot, Orange

Vehicle Mount System:

P/N 9000-21110 45108 8 Watt Spot, Yellow
P/N 9000-21111 45107 8 Watt Spot, Orange
P/N 9000-21115 45104 20 Watt Spot, Yellow
P/N 9000-21116 45102 20 Watt Spot, Orange

Locking Device System:

P/N 9000-40164 Keyed Alike
P/N 9000-40163 Keyed Differently

Replacement Battery:

P/N 9000-99316 45937 Replacement Battery

LITEBOX® Holder (not manufactured by Streamlight)



- Designed to conveniently hold the Streamlight LiteBox® onto the platform
- Made of a polymer material with excellent dielectric, cold weather, and UV properties
- Mounts on the outside of the platform

STREAMLIGHT



E-Flood® LITEBOX® HL™ Rechargeable Lantern

- Six C4® LEDs and wide reflectors produce a uniform flood pattern
 - High: 3,600 lumens; 31,000 candela; 352m beam distance; runs 2 hours
 - Medium for an intense beam and longer run time: 2,400 lumens; 20,000 candela; 283m beam distance, runs 4 hours
 - Low for when a less intense beam is ideal and for longer run times: 1,200 lumens; 11,000 candela; 210m beam distance; runs 8 hours
- Selectable diffuser settings for two beam widths
- Optimum peripheral illumination for scene lighting; 90° swivel neck allows you to aim the beam where you need it for task lighting
- Battery will continue to charge while operating directly from an external 12V DC power source when using the remote cord so you can be confident that you will always have a light when you need it
- Indefinite run time when using 12V DC power cord
- Zero-maintenance 12V, 7.2Ah sealed lead acid rechargeable up to 500 times
- Integral D-rings allow attachment of the included shoulder strap
- High-impact ABS thermoplastic housing and weatherproof construction; elastomer impact bumper; cushioned-grip handle
- Length: 12.3 in. (31 cm)
- Weight with battery: 10.4 lbs (4.7 kg)
- Fits existing LiteBox charge racks
- Standard system includes shoulder strap, AC and DC charger cords and charge rack, and a 10ft (3 meter) external 12V DC power cord



P/N 9704-54076 Model 45661 120V AC/12V DC
P/N 9704-54077 Model 45665 12V DC

THE SIEGE®

Compact, Alkaline Hand Lantern

Ergonomic handle designed to lock in upright or stowed position; Incorporated hook allows for hanging on horizontal rope, cables and pipes

**-RUGGED-
-CORDLESS-
-BATTERY
POWERED-**

Recessed power button prevents accidental actuation; Features battery level indicator

340 Lumens



Removable, polycarbonate, glare-reducing cover provides soft, even 360° light distribution; Comfortable to use in close quarters without impairing vision

**360° Of Soft,
Even Light**



- Multiple modes:

WHITE LED (FOUR C4® LEDs) WITH COVER REMOVED:

- High for brightest light: 340 lumens; runs 30 hours
- Medium for bright light and longer run times: 175 lumens; runs 70 hours
- Low provides extended run times for when less light is needed: 33 lumens; runs 295 hours

RED LED (ONE RED C4® LED):

- Red LED High - Steady (night vision preserving mode): 10 lumens; runs 235 hours
- Flash SOS mode for emergency signaling: 10 lumens; runs 430 hours

- Night vision preserving mode extends run time for emergency preparedness
- Incorporated D-rings on top and bottom of lantern to hang it in either inverted or upright positions. They are spring-loaded to stow against the light, out of the way when not in use.
- Cover is removeable to illuminate large areas. Stand upright or to use as an overhead light, hang it with D-ring incorporated in base of lantern
- Uses three "D" cell alkaline batteries (sold separately)
- Keyed battery door facilitates battery replacement in the dark
- Battery level indicator changes from green, to yellow, to red, then to flashing red when batteries reach the end of their useable life
- Durable, polymer construction with rubber molded base that provides stability on slippery or uneven surfaces
- IPX7 waterproof to 1m submersion; it floats; 2m impact resistance tested
- 7.25 in.; 1 lb. 15 oz. with batteries

THE SIEGE® - COYOTE
P/N 9704-89899 Model 44931

STREAMLIGHT WAYPOINT®



- Powerful, long-reaching beam that illuminates a range of up to 678 meters
- Pistol-grip spotlight features 3 modes: High, low, and emergency signal
- C4® premium LED technology delivers 210 lumens (8.5 hour runtime) on high; 20 lumens (120 hour runtime) on low
- Unlimited runtime using 12V DC power cord (included)
- Optimized electronics provide regulated intensity
- IPX4 rated for water-resistance
- Integrated stand for hands-free scene lighting
- Requires four "C" sized alkaline batteries
- Available in black or yellow



FL1 STANDARD	HIGH	LOW
	210 LUMENS	20 LUMENS
	8h 30min	120h
	678m	245m
	115,000 cd	10000cd

Waypoint With Storage Mount
 P/N 9702-46563 44900 Yellow with Storage Mount; 12V DC
 P/N 9702-46565 44902 Black with Storage Mount; 12V DC

Waypoint Without Storage Mount
 P/N 9703-46622 44904 Yellow Waypoint; 12V DC
 P/N 9703-46623 44905 Black Waypoint; 12V DC

Emergency signal run time 120 hours.

WAYPOINT® RECHARGEABLE SPOTLIGHT

- Featuring a rechargeable Lithium-Ion battery (fully recharges in 4 hours)
- Waterproof to 2 meters and it floats (IPX8 rated)!
- Powerful, long-reaching targeting beam that illuminates a range of up to 610 meters
- Pistol-grip spotlight features 3 modes: high, low, and emergency signal
- C4® premium LED technology delivers 310 lumens (5 hour runtime) on high; 30 lumens (50 hour runtime) on low
- Optimized electronics provide regulated intensity
- Integrated stand for hands-free scene lighting
- Available in black or yellow

P/N 9703-81469* 44910 Yellow; 120V AC
 P/N 9703-81474* 44911 Black; 120V AC
 P/N 9703-81475 44918 Rechargeable Holder
 * Other Models Available

FL1 STANDARD	HIGH	LOW
	370 LUMENS	30 LUMENS
	5h	50h
	610m	170m
	93,000cd	7,200cd



KNUCKLEHEAD® SPOT

The Most Versatile Light You Will Ever Own!

- Rechargeable Work Light
- Circular rare-earth magnet surrounded by durable nickel plated steel housing
- Single parabolic reflector provides a tighter beam for longer range target illumination
- Shockproof C4® LED technology delivers 210 meters on high beam
- Rubber dome push-button actuator is easy to operate even when wearing heavy gloves
- High-impact, super-tough nylon polymer construction for exceptional durability
- Dual power source: accepts rechargeable NiCd battery pack or 4 "AA" alkaline batteries
- Features 4 modes - High, Low, Moonlight, and Flash

Steady Charge Model (AC/DC Charger/Holder)
 P/N 9703-81459*

Model 90757 Orange 120V AC/12V DC

Fast Charge Models

P/N 9703-81461*

Model 90761 Orange; AC Charger

P/N 9703-81466*

Model 90770 Orange; DC Charger 178

* Other Models Available

FL1 STANDARD	HIGH	LOW
	180 LUMENS	55 LUMENS
	3h 30min	16h
	210 m	115m
	11,000 cd	3,300cd



- Head rotates 360°
- Articulates 210°
- Powerful magnet is removable
- Includes a cover to protect painted surfaces
- Sturdy, spring-loaded clip grabs onto turnout gear and other surfaces
- USTC Class 1, Div 1 Rated



STREAMLIGHT KNUCKLEHEAD®

STREAMLIGHT

SEEING EVERY LAST THING

TAKES JUST A SINGLE KNUCKLEHEAD

The Most Versatile Light You Will Ever Own!

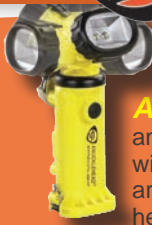

AIM IT
anywhere
with an
articulating
head



ATTACH IT
to steel surfaces
with a powerful
magnet



HANG IT
with an integrated,
stowable hook

Steady Charge Models
(with AC/DC Charger/Holder)

P/N 9702-85635 *
Model 90607 Black 120V AC/DC

P/N 9702-85637 *
Model 90627 Yellow 120V AC/DC
* Other Models Available

Alkaline Models

P/N 9702-91342 *
Model 90641 Black

P/N 9702-91338 *
Model 90642 Yellow
* Other Models Available

- Rechargeable, alkaline work light
- C4® premium LED technology delivers 200 lumens (3.5 hour runtime on high); 63 lumens (6 hour runtime on low)
- Moonlight mode runs 20 days; Flash runs 8 hours
- Features a 210 degree articulating head that rotates a full 360 degrees
- Dual power source: accepts rechargeable NiCd battery pack or 4 "AA" alkaline batteries
- Removable magnet with 135 lb. pull strength
- Optimized electronics provide regulated intensity
- High-impact, super-tough nylon polymer construction
- IPX4 rated for water-resistance
- Available in black or yellow
- Rated Class I & II, Division 2



FL1 STANDARD	HIGH	LOW
	200 LUMENS	63 LUMENS
	3h 30min	16h
	68 m	37m
	1150 cd	350cd

H.I.D. LITEBOX®

- 1,000,000 candela peak beam intensity
- Fully articulating head with deep-dish parabolic reflector that produces a long-range, high-intensity focused beam of light
- Up to 1.75 hours runtime
- 35 watt H.I.D. Xenon lamp
- High-impact ABS thermoplastic housing; weatherproof
- 12V, 7.2Ah sealed lead acid rechargeable up to 500 times
- Serialized for positive identification
- Kit includes 120 Volt AC Charger and 12 Volt DC Charger



P/N 9701-10679 45621 Black H.I.D. LiteBox® Kit
P/N 9701-10681 45601 Orange H.I.D. LiteBox® Kit
P/N 9701-92362 45637 Replacement H.I.D. Bulb Kit

LIGHTING EQUIPMENT

USA: 1-877-GO ALTEC
(1-877-462-5832)

www.alteconnect.com

STREAMLIGHT® FIRE VULCAN® LED



- C4® LED technology and 2 ultra-bright blue taillights
- Light output: High - 145 lumens; Low - 70 lumens
- Runtimes: Steady High LED and taillights - up to 3 hours on high; up to 7 hours on low
- Recharges in 5 hours
- Fits existing Streamlight Vulcan chargers
- 1.85 lbs.; lantern floats
- 8 modes of operation

P/N 9702-16643 44450 Orange LED Standard System 120V with quick release shoulder strap. AC/DC
 P/N 9701-91135 44451 Orange LED Vehicle Mount System 12V with quick release shoulder strap. DC
 P/N 9702-16647 44454 Orange LED Standard System (WITHOUT CHARGER) with quick release shoulder strap.

PORTABLE SCENE LIGHT

RAPIDLY DEPLOYED ~ EASILY STOWED

THE PORTABLE SCENE LIGHT BRINGS 3,600 LUMENS TO YOUR WORK AREA

- Selectable diffuser settings for two beam widths. Works with all three modes
- Optimum peripheral illumination for scene lighting; 90° swivel to aim the beam where you need it for task lighting
- Balanced design and easy setup:
 - Less than 30 seconds for full deployment
 - Pole extends to 72"; cord built into the pole to avoid snags
 - Stabilization legs provide balance on uneven surfaces
- Packs to a compact size (22"; 55.88cm) for easy stowage
- Six C4® LEDs and wide pattern parabolic reflectors produce a smooth flood pattern; optimized electronics provide regulated intensity
- Light output: High - 3,600 lumens, 31,000 candela, runs 5 hours; Medium - 2,400 lumens, 20,000 candela, runs 9 hours; Low - 1,100 lumens, 11,000 candela, runs 18 hours;
- Indefinite run time with 12V power cord



P/N 9705-95100 45670 Portable Scene Light with 120V AC/12V DC - Yellow

WITH ITS NARROW FOOTPRINT AND 72" EXTENSION POLE, THE LIGHT GOES ALMOST ANYWHERE, FROM WIDE OPEN PLACES TO TIGHT, CONFINED SPACES.

FL1 STANDARD	HIGH	MEDIUM	LOW
	3,600 LUMENS	2,400 LUMENS	1,100 LUMENS
	5h	9h	18h
	352m	283m	210m
	31,000cd	20,000cd	11,000cd



STREAMLIGHT HEADLAMPS



LIGHTING EQUIPMENT

ARGO®, TRIDENT®, SEPTOR® HEADLAMPS



ARGO®
Far-reaching beam illuminates objects at a distance

TRIDENT®
Versatile long-range beam with a soft flood pattern

SEPTOR®
A wide flood pattern illuminates your work area

NEW & IMPROVED!

- Multi-function push-button switch easy to use when wearing gloves and is recessed to prevent inadvertent activation
- 90° tilting head with a new, more durable ratcheting system, prevents neck fatigue
- Low-level battery indicator

ARGO® HEADLAMP

SHINES BRIGHTER & REACHES FARTHER!

When your task requires both hands and 150 lumens of bright light with a far reaching beam (190 meters).

- 3 lighting modes:
 - High for maximum output with a long-range beam distance
 - Medium for intense brightness and longer run time
 - Low for extended run times and when a less intense beam is ideal
- 1 C4 LED
- Powered by three "AAA" alkaline batteries
- C-ETL-US Classified Class I, Div 2, Groups A,B,C,D; Class II, Div 2, Groups F,G; Class III, T5

150 LUMENS!



FL1 STANDARD	HIGH	MEDIUM	LOW
	150 LUMENS	100 LUMENS	45 LUMENS
	3h	4h 30m	30h
	190m	160m	103m
	9250cd	6375cd	2750cd

Specifications and Models

P/N 9000-61301 Model 61301 Yellow

TRIDENT® HEADLAMP

When you need the versatility of switching between either a bright light to illuminate objects at a distance (126 meters) or a soft flood light for tasks at arm's length.

- Center C4® LED, 3 white 5mm LEDs
- 3 lighting modes:
 - C4 LED for super-bright light with strong beam distance
 - Three 5mm LEDs for intense brightness and longer run time
 - One 5mm LED for extended run times and when a less intense beam is ideal
- Powered by three "AAA" alkaline batteries
- C-ETL-US Classified Class I, Div 2, Groups A,B,C,D; Class II, Div 2, Groups F,G; Class III, T5

NOW SHINES BRIGHTER!
80 LUMENS!



FL1 STANDARD	C4 LED (WHITE)	3 WHITE LEDs	1 WHITE LED
	80 LUMENS	35 LUMENS	11 LUMENS
	5h	10h	53h
	126m	39m	22m
	4000cd	385cd	120cd

Specifications and Models

P/N 9000-61050 Model 61050 Yellow

SEPTOR® HEADLAMP

When you need a hands-free flood light for tasks at arm's length, the Septor gives you 120 lumens of a soft, wide beam to illuminate your work area.

- 3 lighting modes:
 - 7 LEDs for a soft flood light for tasks at arm's length
 - 3 LEDs for light without the glare and longer run time
 - 1 LED for extended run times and when a less intense beam is ideal
- 7 ultra bright 5mm LEDs
- Powered by three "AAA" alkaline batteries
- C-ETL-US Classified Class I, Div 2, Groups A,B,C,D; Class II, Div 2, Groups F,G; Class III, T5

SEVEN LED HEADLAMP!
120 LUMENS!



FL1 STANDARD	7 LEDs	3 LEDs	1 LED
	120 LUMENS	45 LUMENS	13 LUMENS
	3.5h	10h	55h
	60m	35m	20m
	900cd	375cd	100cd

Specifications and Models

P/N 9000-61007 Model 61052 Yellow



STREAMLIGHT HEADLAMPS

LIGHTING EQUIPMENT

USA: 1-877-GO ALTEC
(1-877-462-5832)

www.alteconnect.com

3AA HAZ-LO® Division 1 HEADLAMP SUPER HIGH-FLUX LED

- Parabolic reflector produces long range brilliance and smooth uniform beam pattern
- Impact-resistant housing - drop-test verified; 1 meter impact resistance tested
- Up to 34 lumens and 11 hours of continuous use
- C4® LED technology, impervious to shock with a 50,000 hour lifetime
- Powered by three "AA" alkaline batteries
- UL, C-UL Classified Class 1, Division 1, Groups A,B,C,D, Class II, Division 1, Groups E,F,G Class III, Temperature Code: T4
- Rubber hard hat strap and elastic strap (Included in purchase)
- 90 degree tilting head

Specifications and Models

P/N 9700-89240 Model 61200



FL 1 STANDARD	3AA HAZ-LO
	120 LUMENS
	11h
	165m
	6800 cd

3AA PROPOLYMER® HAZ-LO®

SAFETY RATED FLASHLIGHT This feature-laden, safety approved flashlight was designed to meet the stringent requirements of ANSI/UL 913 CAN/CSA C22.2 No. 157-92 intrinsically safe equipment for use in hazardous locations.

- High-performance, anti-static, thermoplastic material resistant to chemicals and solvents
- "Captured locking" set screw will not back out - prevents FOD (Foreign Object Debris)
- Safety measure: Set screw helps to avoid batteries being changed out, or the housing inadvertently being opened in a hazardous environment
- Visual and mechanical polarity protection helps ensure correct installation of batteries
- C4® LED technology - impervious to shock with a 50,000 hour lifetime - provides 120 lumens; runs 6.5 hours
- Sealed switch design protects it from corrosion caused by battery leakage
- Smooth parabolic reflector produces a tight beam with optimum peripheral illumination
- Regulated run time provides consistent performance throughout battery life
- IP67 rated for dust-tight and waterproof to 1 meter for 30 minutes; IPX4 for water spray
- 3 meter impact resistance tested
- Ergonomically designed for maximum hand comfort
- 7.00 in. (17.78 cm); 7.5 oz (213 grams) with batteries (included)
- Limited Lifetime Warranty



Specifications and Models

P/N 9704-35088* Model 68720 Yellow
 P/N 9704-35089* Model 68721 Black
 P/N 9704-35090* Model 68722 Orange

FL 1 STANDARD	3AA PROPOLYMER HAZ-LO
	120 LUMENS
	6h 30min
	237m
	14,000cd

STREAMLIGHT

POLYTAC[®] SERIES



POLYTAC[®]

- C4[®] LED technology within a parabolic reflector produces a concentrated beam with optimum peripheral illumination
- TEN-TAP[®] Programming: high/strobe/low; high only; low/high
- High: 275 lumens, 9,500 candela, 195m beam distance; runs 3 hours
- Low: 14 lumens, 500 candela, runs 65 hours
- Strobe for disorienting or signaling: runs 5.5 hours
- High impact super tough nylon polymer
- Superior grip texture for a comfortable but slip-resistant feel
- Available in Black, Coyote Tan, and Yellow
- IPX7 rated design; waterproof to 1 meter
- Powered by two 3-volt CR123A lithium batteries (included)

P/N 9702-16648 88850 Black
 P/N 9702-16649 88851 Coyote Tan
 P/N 9702-16650 88853 Yellow

FL1 STANDARD	HIGH	LOW
	275 LUMENS	14 LUMENS
	3h	65h
	195m	45m
	9,500cd	500cd



POLYTAC[®] HP

- The high-performance model of the PolyTac with a C4[®] LED for down-range illumination
- TEN-TAP[®] Programming:
 - 1.) high/strobe/low (factory default); 2.) high only; 3.) low/high
- High: 275 lumens, 19,000 candela, 275m beam distance; runs 3 hours
- Low: 14 lumens, 1,000 candela, runs 56 hours
- Strobe for disorienting or signaling: runs 5.5 hours
- Superior grip and texture for a comfortable but slip-resistant feel
- C4[®] LED technology, impervious to shock with a 50,000 hour lifetime
- Powered by two 3-volt CR123A lithium batteries
- High impact super tough nylon polymer
- Waterproof to 1 meter (IPX7 rated) for 30 minutes

P/N 9702-46581 88860 Black with Lithium Batteries
 P/N 9702-46585 88863 Yellow with Lithium Batteries

FL1 STANDARD	HIGH	LOW
	275 LUMENS	14 LUMENS
	3h	56h
	275m	63m
	19,000cd	1,000cd

PROTAC[®] TACTICAL SERIES



PROTAC[®] 2AA

- Ten-Tap[®] Programming: high/strobe/low, high only, or low/high
 - C4[®] LED illumination output and runtimes:
 - HIGH - 155 lumens/2 Hours
 - LOW - 11 lumens/36 Hours
 - STROBE - Runs 4 hours
 - Waterproof to 1 meter for 30 minutes
 - Includes two "AA" alkaline batteries
- P/N 9702-46566 88033



PROTAC[®] 2L

- Ten-Tap[®] Programming: high/strobe/low, high only, or low/high
 - C4[®] LED illumination output and runtimes:
 - HIGH - 260 lumens/3 Hours
 - LOW - 13 lumens/50 Hours
 - STROBE - Runs 6 hours
 - Includes 2 CR123A lithium batteries
 - Waterproof to 1 meter for 30 minutes
- P/N 9702-46575 88031



PROTAC[®] 1AA

- Ten-Tap[®] Programming: high/strobe/low, high only, or low/high
 - C4[®] LED illumination output and runtimes:
 - HIGH - 70 lumens/2 Hours
 - LOW - 5 lumens/32 Hours
 - STROBE - Runs 4 hours
 - Includes 1 "AA" alkaline battery
 - Waterproof to 1 meter for 30 minutes
- P/N 9702-46568 88032



PROTAC[®] 1L

- Ten-Tap[®] Programming: high/strobe/low, high only, or low/high
 - C4[®] LED illumination output and runtimes:
 - HIGH - 180 lumens/2 Hours
 - LOW - 12 lumens/24 Hours
 - STROBE - Runs 4 hours
 - Includes 1 3V CR123A lithium battery
 - Waterproof to 1 meter for 30 minutes
- P/N 9702-46578 88030

LIGHTING EQUIPMENT

USA: 1-877-GO ALTEC
 (1-877-462-5832)

www.alteconnect.com

STREAMLIGHT TACTICAL HAND-HELD SERIES

SCORPION® HL

FL 1 STANDARD	HIGH	LOW
	600 LUMENS	33 LUMENS
	1h 15 min	18h
	253m	57m
	16,000cd	800cd

- TEN-TAP® Programming: high/strobe/low; high only; low/high
 - C4® LED technology
 - High - 600 Lumens, 1.25 hours runtime; Low - 33 lumens, 18 hours runtime
 - Strobe (for disorienting or signaling) runs 2.5 hours
 - Two 3V CR123A lithium batteries (included)
 - 1 meter impact-resistance tested
 - Rubber-amored sleeve
- P/N 9705-95115 85400 Black



STINGER® SERIES

The series of Stinger® rechargeable flashlights offer you the advantages of a full-size light in a case the length of your palm. The lights are made of a machined aircraft aluminum that is anodized against corrosion inside and out. Streamlight's PolyStinger® flashlights provide you with the features and brightness you expect from a Stinger, in a super-tough, non-conductive nylon polymer with non-slip rubberized comfort grip.

STINGER® LED

- C4® LED technology with a 50,000 hour lifetime
- Runtime: High - up to 2 continuous hours; Medium - up to 3.75 continuous hours; Low - up to 7.25 continuous hours
- 3-cell, 3.6 Volt Ni-Cd sub-C battery, rechargeable up to 1000 times
- Fits existing Stinger snap-in chargers

P/N 9703-46631 75713 Black with AC/DC Standard Charger - 2 holders
P/N 9703-46632 75735 Black with AC/DC Fast Charger - 2 holders



FL 1 STANDARD	HIGH	MEDIUM	LOW
	350 LUMENS	175 LUMENS	85 LUMENS
	2h	3h 45min	7h 15min
	310m	219m	155m
	24,000cd	12,000cd	6,000cd

STINGER LED HL® / STINGER DS LED HL®

Streamlight's HL Series - now available in rechargeable systems! When you need maximum illumination with a wide beam to search a large area, the Stinger LED HL rechargeable, high lumen flashlight provides a blast of 640 lumens with 297 meters of beam distance.

- Multi-function On/Off push-button switch lets you choose three lighting modes and strobe
- Deep-dish parabolic reflector produces a concentrated beam with optimum peripheral illumination
- C4® LED technology, impervious to shock with a 50,000 hour lifetime
- DS mode features both a head-mounted switch and a second multi-function tactical tailswitch
- 3-cell, 3.6 Volt Ni-MH sub-C battery, rechargeable up to 1000 times
- Fits existing Stinger chargers
- Machined aircraft aluminum body with non-slip rubberized comfort grip; anti-roll rubber ring included
- IPX4 water-resistant; 1 meter impact resistance tested
- Unbreakable polycarbonate lens with scratch-resistant coating
- Stinger LED HL: 8.41"; 12.4 oz.
- Stinger DS LED HL: 8.85"; 12.8 oz.
- Serialized for positive identification
- Limited lifetime warranty



Specifications and Models

FL 1 STANDARD	HIGH	MEDIUM	LOW
	640 LUMENS	340 LUMENS	170 LUMENS
	1h 15min	2h	4h
	297m	210m	148m
	22,000cd	11,000cd	5,500cd

STINGER LED HL®
P/N 9704-35073* Model 75430
120V AC/12V DC Chargers (2 Holders)

STINGER DS LED HL®
P/N 9704-35083* Model 75454
120V AC/12V DC Chargers (2 Holders)
* Other Models Available



STREAMLIGHT'S HL SERIES
NOW AVAILABLE IN RECHARGEABLE SYSTEMS!



STREAMLIGHT

STREAMLIGHT JR.[®] & STRION[®] LED

LIGHTING EQUIPMENT

STREAMLIGHT JR.[®] LED



- Ultra-compact, lightweight flashlight
- C4[®] LED technology
- Up to 85 lumens output
- Runtime: "AA" Alkaline batteries - 4 hours; "AA" (L91) Lithium batteries - 5.25 hours
- Removable pocket clip
- Powered by two "AA" alkaline batteries (included)

P/N 9000-71500 71500 Streamlight Jr.[®] C4 LED with Holster
 P/N 9000-70129 71503 Stand Alone Holster

FL 1 STANDARD	STREAMLIGHT JR.
	85 LUMENS
	4h
	123m
	3800 cd

STRION LED HL[®]



- C4[®] LED technology
- Three modes and strobe: High - 500 lumens; 1 hour runtime
 Medium - 250 lumens; 2 hour runtime
 Low - 125 lumens; 3.5 hour runtime
 Strobe runs 2.5 hours
- Lithium ion battery, rechargeable up to 1000 times
- LED charge continuity indicator on charger base
- IPX4 rated design; water-resistant operation
- 2 meter impact resistance

P/N 9705-95555 74752 Black Strion LED HL w/120V AC/12V DC - 2 holders

FL 1 STANDARD	HIGH	MEDIUM	LOW
	500 LUMENS	250 LUMENS	125 LUMENS
	1h	2h	3h 30min
	200m	141m	100m
	10,000cd	5,000cd	2,500cd

STYLUS[®] SERIES



STYLUS PRO[®] USB



- Compact flashlight with C4[®] LED technology
- Rechargeable using supplied USB cord and AC wall adapter
- 70 lumens; 3.5 hours runtime
- Lithium ion battery fully recharges in-product in 2.5 hours; rechargeable up to 300 times
- Removable pocket clip and tear resistant nylon holster

P/N 9705-95119 66133 120V AC adapter, USB cord, nylon holster

FL 1 STANDARD	C4 WHITE LED
	70 LUMENS
	3h 30min
	50 m
	630cd

STYLUS PRO[®]



- Sleek, compact flashlight the size of a pen
- C4[®] LED technology
- 65 lumens median output; 6.5 hours runtime
- Powered by two "AAA" alkaline batteries (included)
- Tear-resistant nylon holster
- Unbreakable, removable pocket clip

P/N 9701-31481 66118 Black with C4 White LED

FL 1 STANDARD	C4 WHITE LED
	65 LUMENS
	6h 30min
	52m
	690cd

USA: 1-877-GO ALTEC
(1-877-462-5832)

www.alteconnect.com



Hazardous Location Wide-Area Lighting Quartz Halogen Stanchion

- Two 300W quartz halogen lamps provide 10,000 lumens
- Class 1, Division 1, Groups C, D; T3C temperature rating
- NEMA 4X enclosure
- Operating temperature range -25C to +40C
- Operating voltage 120V
- Rugged cast aluminum heads and unique rubber lens gasket provide strength and durability
- 600V rated SOOW cord
- Provided with hazardous location rated NEMA 5-15 plugs
- Includes sturdy collapsible tripod and case for easy storage



Altec	Molex	AWG Size	Length (ft)
9705-88880	S2300-HZX025163	16/3	25
9705-88881	S2300-HZX050163	16/3	50

LED Wide Area



- Four 20W LED arrays provide 5270 lumens at 5100K color temperature
- Class 1, Division 2, Groups B, C, D; T4A temperature rating
- NEMA 3 enclosure
- Operating temperature range -40C to +40C
- Operating voltage 120 to 277
- Rugged cast aluminum enclosure and rubber & polycarbonate lens
- 600V rated SOOW cord
- Provided with non-hazardous rated plugs
- Versatile mounting clamps provide mounting flexibility

Altec	Molex	AWG Size	Length (ft)
9705-88882	1076HZ25025143	14/3	25
9705-88883	1076HZ25050143	14/3	50

Stringlights

- SOOW rubber cord provides highest level of performance
- Guards pre-assembled on all but 5030
- Bulbs not included



Altec	Molex	Cord Type	Number of Light Sockets	Guard Included	Cord Length	Plug Type
9705-88884	323526	12/3 SOOW	5	Metal	50	NEMA 5-15, Watertite
9705-88885	323126	12/3 SOOW	10	Metal	100	NEMA 5-15, Watertite
9705-88886	302SRL	12/2 TC	10	Plastic	100	NEMA 1-15, Watertite
9705-88887	5030	14/2 SJTW	10	Plastic	100	NEMA 1-15, Molded

Wide Area Magnet Lights



- Heavy-duty mounting magnet means easy installation on many metal surfaces
- Feed-thru connector option makes it easy to string together multiple fixtures
- Choice of metal halide or high-pressure sodium
- Voltage 120V; 70W
- Suitable for wet locations
- Cast aluminum housing and polycarbonate lens
- Provided with NEMA 5-15 plug; Watertite connector on feed-thru models

Altec	Molex	Lamp Type	Primary Cord Length (Ft)	Secondary Cord Length (Ft)
9705-88751	8565F	HPS	10	1
9705-88752	8565F-MH	MH	10	1
9705-88753	8565	HPS	10	
9705-88754	8565-MH	MH	10	



Legend® LPX Discrete

- All-LED, discrete-traditional cable lightbar
- High-output Solaris® LED reflector technology
- LEDs offered in Amber, Blue, Green, Red and White
- Five-year LED warranty

P/N 9703-92450 LPX45D-00033 45" Lightbar, 14 Flashing Heads, Class 1
 P/N 9703-92815 LPX53D-00042 53" Lightbar, 18 Flashing Heads, Class 1
 P/N 9703-92817 LPX61D-00027 61" Lightbar, 22 Flashing Heads, Class 1



VPX SignalMaster™

- Eight high-powered LEDs in each Viper EXT module
- Available directional patterns include: left, right, center-out and flashing warning
- Fully-encapsulated, water resistant modules
- Five-year LED warranty on Viper EXT LED modules

P/N 9702-47006 320882 42", (8) LED Modules, 30-ft Cable
 P/N 9704-66026 320892 51", (8) LED Modules, 50-ft Cable
 P/N 7052-01298 331105-SB Full-featured SignalMaster™ Controller
 P/N 0684-55025 330104 Standard SignalMaster™ Controller

*SignalMaster™ controller is required to operate the unit



HighLighter™ LED

- Low profile; only 2.6" tall
- High-output Solaris® LED reflector technology
- Uniform 360° light distribution; 20 user selectable flash patterns
- Five-year LED warranty

P/N 9701-27407 454201-02SC Amber LEDs, Amber Dome, Permanent Mount, Class 1



HighLighter™

- Compact size; 15" long
- Two 55-watt halogen reflectors produce an effective 80,000 candelas each
- Raised base makes installation quick and easy
- Five-year product warranty

P/N 8939-11970 450112-02 Amber (2) 95 FPM Rotators Diagonal Mirror, Permanent Mount Class 1, Title 13



Latitude™ SignalMaster™

- High-output Solaris® LED reflector technology
- Left, right and center-out warning signals
- Comes equipped with economy SignalMaster controller
- Five-year LED warranty

P/N 9705-27156 SL6S-A 6-Head Latitude™ SignalMaster™, 24.2" Amber, Class 1, Title 13
 P/N 9705-11212 SL8S-A 8-Head Latitude™ SignalMaster™, 31.8" Amber, Class 1, Title 13



LED SignalMaster™

- Each module contains 32 powerful Amber LEDs, drawing 0.30 amps
- Available directional patterns include: left, right, center-out and flashing warning
- Corrosion-resistant black aluminum housing
- Five-year LED warranty

P/N 0684-55024 320772 42", 15-ft Cable
 P/N 9700-50659 320782 42", 30-ft Cable
 P/N 9700-11275 320792 51", 30-ft Cable
 P/N 7052-01298 331105-SB Full-Featured SignalMaster™ Controller
 P/N 0684-55025 330104 Standard SignalMaster™ Controller

*SignalMaster™ controller is required to operate the unit

SLR Beacon

- Rotating LED beacon with 12 high-powered LEDs
- Utilizes Federal Signal's patented SLR (Solaris® LED Rotator) technology
- 70/90/120 RPM
- Five-year LED warranty



P/N 9703-92461 272650-02 Amber LEDs, Amber Dome, Permanent Mount, Class 2

UltraStar® LED

- Industry standard mounting for quick and easy retrofits
- Longer dwell time to enhance visibility at a distance
- Fourteen selectable "strobing" flash patterns
- Five-year LED warranty



P/N 9700-41444 252650-02SC Amber Dome, 1-Inch Permanent/Pipe Mount, Class 1

Pulsator® LED

- LED technology for zero maintenance lighting; no bulbs or strobe tubes to replace
- Multi-voltage, 12-24 VDC
- Fourteen selectable “strobing” flash patterns
- Five-year LED warranty

P/N 9701-62088 212660-02SB Amber Dome, Tall, Permanent Mount, Class 1



Model 651

- Low-profile beacon available in LED or strobe
- Aluminum base and polycarbonate dome
- Branch guard and blackout lens
- Five-year warranty

P/N 0684-51218 420221-02 LED 651 Beacon, Class 2
P/N 0684-51081 420209-02 Strobe 651 Beacon, Class 2



UltraStar® US5

- Polycarbonate dome and die-cast aluminum base are durable and corrosion resistant
- Strobe tube is housed in a silicone base that absorbs vibration
- Five-year product warranty

Short Dome:

P/N 8100-00540 251121-02 13-Joule, Double Flash, Class 2
P/N 0684-51065 251821-02 14-Joule, Quad Flash, Class 2
P/N 0684-51039 251500 Replacement Tube

Tall Dome:

P/N 0684-51059 250121-02 13-Joule, Double Flash, Class 1
P/N 0684-51039 251500 Replacement Tube



Firebolt® LED

- Polycarbonate base and dome
- Multi-voltage, 12-24 VDC
- Fourteen selectable flash patterns
- Five-year LED warranty

P/N 9705-71088 220250-02 Permanent/PipeMount
P/N 9705-71105 220260-02 Magnet Mount with Cigarette-Plug



Model 100

- Powerful 80,000 candela rotator that draws only 4.3 amps
- Rotator assembly “floats” on a neoprene washer to absorb vibrations
- Five-year warranty

P/N 8939-14080 443112-02 Amber Dome, Tall, Permanent Mount, Class 1



MicroPulse™ 3/6/12

- Slim, low-profile design offers a wider range of mounting locations
- Twelve (MPS3), nineteen (MPS6), or twenty-five (MPS12) selectable flash patterns
- Single/multi-unit synchronization
- Three-year LED warranty

P/N 9703-63839 MPS300-A 3-LED Lighthouse, Surface Mount, Amber, Class 2
P/N 9704-10999 MPS300-W 3-LED Lighthouse, Surface Mount, White, Class 2
P/N 9703-46655 MPS600-AA 6-LED Lighthouse, Surface Mount, Amber/Amber, Class 1
P/N 9703-46654 MPS600-WW 6-LED Lighthouse, Surface Mount, White/White, Class 1
P/N 9705-70322 MPS1200-AA 12-LED Lighthouse, Surface Mount, Amber/Amber, Class 2



IMPAXX® 3/6

- High-output Solaris® LED reflector technology
- Twenty-three (IPX3) or twenty-five (IPX6) flash patterns available
- Compact size allows for a variety of mount locations
- Five-year LED warranty

P/N 9701-62089 IPX302-2 Amber LEDs, Off-Axis Lens, Class 2
P/N 9703-39965 IPX602-A Amber LEDs, Off-Axis Amber Lens, Horizontal Mounting, Class 1

P/N 9703-39969 IPX620-WA Amber/White LEDs, Off-Axis Lens, Horizontal Mounting, Class 1



Sentry®

- Compact size for a variety of mounting options
- Produces an attention-getting 80,000 candelas per flash
- Twist-off dome for easy maintenance
- Five-year warranty

P/N 0684-51058 448112-02 Permanent Mount, 95FPM
P/N 7052-01079 449112-02 Permanent Mount, 175FPM
P/N 8110-01231 448330 Branch Guard



In-Line Corner LED Systems



- Built-in 19 selectable flash patterns
- Mounts into a universal 1-inch diameter hole
- Waterproof and vibration resistant
- Three-year LED warranty

P/N 9702-90180 416200-22 Amber/Amber, (2) LED Heads with In-Line Flasher

P/N 9705-70324 416200-44 Red/Red, (2) LED Heads with In-Line Flasher

P/N 9703-46659 416200-55 Clear/Clear, (2) LED Heads with In-Line Flasher

VisiBeam®



- “Gradual start” enables pinpoint placement of the lightbeam
- Continuous 360° horizontal and 140° vertical adjustment
- Operated by a handheld remote control with an indicator light to show when spotlight is in use
- Three-year warranty

P/N 0684-35069 620122 100W, 12VDC Adjustable Spot Light, Surface Mount

P/N 9000-88954 620502 Replacement Bulb

Commander® Series



- LED spot and flood light capability
- Generates up to 20,000 lumens of super bright white light
- Innovative cooling fins provide higher efficiency and more light
- Five-year LED warranty

P/N 9705-60112 COM120-ON-530SW 20K Lumens, Side Mount Bottom-Raise Pole 120VAC, On, Off and Indicator Switch

P/N 9705-66322 COMLC15K-530SW 15K Lumens, Side Mount Bottom-Raise Pole 12/24 VDC, Indicator Switch

Additional Commander models and options available. Please contact your Altec Supply Account Manager or call 1-877-GO-ALTEC (1-877-462-5832) for additional information.

Evacuator® Plus



- Solid-state design protects and resists the effects of vibration
- Alarms operate at 12/24 VDC drawing only 0.15A
- Meets SAE J994, OSHA and MSHA requirements
- Three-year product warranty

P/N 0608-70026 210331SSG 97 dB(A), SAE J994 Type C, Nickel-Plated Threaded Terminals



2012 Series Alarms

- Available in 87 dB(A), 97 dB(A) and 102 dB(A) models with wires or stud terminals
- Alarms operate at 12/24 VDC, drawing only 0.5A
- Meets SAE J994, CE, OSHA and MSHA requirements
- Three-year product warranty

P/N 9703-92464 210238-S 87 dB(A) J994 Type D, Stud Terminals

P/N 9703-92466 210239-S 97 dB(A) J994 Type C, Stud Terminals

P/N 9703-92467 210240-S 102 dB(A) J994 Type F, Stud Terminals

P/N 9703-92468 210238-W 87 dB(A) J994 Type D, Wires

P/N 9703-92469 210239-W 97 dB(A) J994 Type C, Wires

P/N 9703-92470 210240-W 102 dB(A) J994 Type F, Wires

Mobile Camera Systems



- High-resolution, color Sony® CCD Camera
- Camera equipped with day/night sensor
- TFT-LCD color monitor
- Three-year product warranty

P/N 9701-57236 CAMSET56-NTSC-2 5.6" monitor with 2 camera input, standard rear-view camera

P/N 9703-29767 CAMSET70-NTSC4B 7.0" monitor with 4 camera input, standard rear-view camera

Amber Beacons, Lighthoods & Mini Lightbars



L21 Series Super-LED® Beacon

- SAE Class 1 Certified
- High profile beacon with a polycarbonate base
Combination mounting: permanent, pipe (1" NPT) and J-hook supplied with 6" pigtail
- Combination mount available with photocell Hi/Low, contact factory
- Multiple built-in Scan-Lock™ flash patterns plus SignalAlert™ default pattern
- BGH branch guard, high dome
- Five year LED Warranty

P/N 9705-70180 L21HAP with BGH



L31 Series Super-LED Beacon

- SAE Class 1 Certified
- High profile, permanent mount
- Heavy-duty powder coated die-cast base
- Multiple Scan-Lock flash patterns plus 4 simulated rotating patterns and cruise light. Alternately or simultaneously flash multiple patterns (Cross-Link™) with up to eight Whelen Super-LED 360° beacons
- Encapsulated electronics for moisture and vibration resistance
- L360BGB branch guard kit for L31 allows 1" NPT pole mounting
- Five year LED Warranty

P/N 9701-02931 L31HAF with L360BGB



Mini Century™

- SAE Class 1 Certified
- Permanent mount, Super-LED mini lightbar
- Extruded aluminum platform for rugged, long-life dependability
- Standard current switching with Scan-Lock flash patterns and pattern override
- Low profile with compression fit gasket for superior moisture resistance
- Five year LED Warranty

P/N 9704-11115 MC16PA



Responder® LP

- SAE Class 1 Certified
- Permanent mount includes 6" pigtail
- Super-LED low profile linear (LIN6™) mini lightbar
- Multiple Scan-Lock flash patterns with 4 simulated rotating patterns
- Polycarbonate dome with smooth exterior will not gather dirt and dust
- Five year LED Warranty

P/N 9701-62775 R2LPPA



500 Series

- LIN6 Super-LED horizontal mount, optional mounting required
- Designed to meet or exceed current and proposed SAE applicable standards
- Multiple Scan-Lock flash patterns plus steady-burn
- Encapsulated electronics for moisture and vibration resistance
- 5GROMMET rubber grommet kit
- Five year LED Warranty

P/N 9705-70292 50A02ZAR with 5GROMMET



4" Round Super-Led Lighthoods

- 4" Round, TIR6™ Super-LED flat lens
- Certified as system component to SAE specifications
- TIR6 includes steady-burn and the ability to alternately or simultaneously flash multiple lighthoods with optional LED flasher
- 2GROMMET rubber grommet kit
- Five year LED Warranty

P/N 9705-70192 2FA00ZAR with 2GROMMET



ION™ Super-LED V-Series™ (patent pending)

- Amber, single color warning only with combination 180° and TIR directional warning lights
- Surface mount with Black flange
- Multiple Scan-Lock flash patterns
- Five year HDP® Heavy-Duty Professional warranty

P/N 9705-70186 IONSV1A



V23 Series™

- SAE 845 Class 1 Certified
- Combination three-in-one surface mount light includes Class 1 color warning, white flood/work and ground illumination.
- 180° wide-angle warning
- Hard-coated lenses with HDO™
- Five year LED Warranty

P/N 9705-08851 V23ATPB



600 Series Rota-Beam™

- SAE Class 1 Certified surface mount lighthouse with hard-coated color lens. 180° horizontal light spread
- Multiple Scan-Lock flash patterns; some with varying flash rates for an almost unlimited choice of internally controlled warning patterns
- Moisture and vibration resistant
- Synchronize with up to eight like Whelen lighthoods.
- 6FLANGEB is a Black flange
- Five year warranty

P/N 9705-70190 6RBA with 6FLANGEB



Vertex™ Super-LED Hide-A-Way

- Amber. Ultra small, self-contained, hemispheric LED light with in-line lamp driver
- For surface mount or internal mount within composite head lamps, cornering lamps and taillight assemblies
- Multiple Scan-Lock flash patterns
- VTXFB is a Black flange
- Five year LED Warranty

P/N 9705-70197 VTX609A with VTXFB



White Illumination Products



LIGHTING EQUIPMENT

Pan & Tilt™ Super-LED® Spotlight



- Wired (PT360F) or wireless (PT360FW) controlled spotlight with polycarbonate base, flange mount and hard-coated lenses
- Proportional push-button control for quick and easy operation
- Low amp draw, 12VDC
- Tilts 90° up and 20° down. Pans 420° horizontally. Defaults to home position after use
- Five year LED Warranty

P/N 9703-89362 PT360F **Wired**
P/N 9703-89446 PT360FW **Wireless**

Pioneer Plus™ Surface Mount

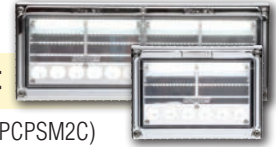

- Single panel (PCPSM1C) or dual panel (PCPSM2C)
- Combination spot/flood (patent pending) optic design projects light directly down at 5° producing illumination to the side of the vehicle arching upward to 90° pattern of light
- Solid-state electronics and LEDs are rugged and reliable, eliminating the high cost of lamp or ballast replacement
- Rugged extruded aluminum housing
- Five year LED Warranty

P/N 9705-70202 PCPSM1C **Single Panel**
P/N 9705-70208 PCPSM2C **Dual Panel**

Pioneer Micro™



- Rugged, die-cast aluminum powder coated housing in Black. Bail/stud mount
- Rated to last thousands of hours with remarkable bright light
- 8° spotlight pattern, comes standard. Includes three additional optic lenses for a light pattern choice of: 90° x 20° wide flood, 40° x 20° flood and 40° x 8° horizontal flood
- Optic lens changes easily via four screws in picture frame fixture
- Five year HDP® Heavy-Duty Professional warranty

P/N 9703-61864 MPBB

Pioneer Nano™ Series



- Available in 3 (NP3BB) or 6 (NP6BB) diode models
- Rugged, die-cast aluminum powder coated housing in Black
- Rated to last thousands of hours with remarkable bright light
- 8° spotlight pattern, comes standard. Includes additional optic lens for a light pattern of 40° x 20° flood. Optic lens changes easily via four screws in picture frame fixture
- Powder coated stainless steel bail bracket with 3/8" stud carriage bolt mount
- Five year LED Warranty

P/N 9705-70283 NP3BB **3 Diode**
P/N 9705-70285 NP6BB **6 Diode**

PAR-36 Super-LED Floodlight Lights



- Floodlight model
- Black heavy-duty cast aluminum housing. Pedestal/swivel mount. Stainless steel bracket and hardware included
- Ultra bright Super-LED with low current draw
- 12 diode
- Two intensities available
- Five year LED Warranty

P/N 9702-91056 PFBP12

Hand Held Spotlights



- Spotlight model
- Hand held work light
- 90# pull magnet mount with 8' coiled cord and cigar plug
- 18 diode
- 12VDC
- Waterproof durable built-in push-button On/Off switch
- Five year LED Warranty

P/N 9705-70287 P46HHS

Strip-Lite™ Series



- Compartment lights feature 18 Super-LEDs and clear frosted lens for increased light output and light spread
- Surface mounted. Only a small wire access hole and two screws to install
- Sturdy. Encapsulated, no glass or filaments to break
- Low current consumption
- Five year LED Warranty

P/N 9701-09584 PSC0CDCR

USA: 1-877-GO ALTEC
(1-877-462-5832)

www.alteconnect.com

THE TWINRAY™ CONTROLLER

INDEPENDENTLY CONTROL ONE OR TWO NIGHTRAY OR STARBEAM SPOTLIGHTS WITH ONE CONTROLLER!

GREEN OR RED INDICATOR LIGHTS DISPLAY WHICH LIGHT IS SELECTED.

STANDARD AAA BATTERY OPERATION



EMERGENCY LED FLASHLIGHT

CLEAR AND CONSISTENT NOISE FREE COMMUNICATION IS PROVIDED BY KH'S EXCLUSIVE MULTIPLE R.F. CODE SEQUENCING WITH POSITIVE IDENTIFICATION, ELIMINATING FALSE SIGNALS FROM OTHER R.F. TRANSMITTERS AND ENVIRONMENTAL NOISE.

EASY IN FIELD PROGRAMMING WHEN ADDING A SPOTLIGHT.

WILL CONTROL SPOTLIGHT FROM UP TO 100' AWAY.

BRIGHT, SAFETY YELLOW COLOR IS EASY-TO-FIND.

ERGONOMICAL DESIGN, LARGE BUTTONS FOR EASY GLOVED-HAND USE.



NightRay®

A/B

☺☹

OFF

KH

THE TWINRAY CONTROLLER WAS DESIGNED BY REQUEST OF UTILITY LINEMAN AND IS AVAILABLE EXCLUSIVELY WITH KH INDUSTRIES NIGHTRAY 2 AND STARBEAM 2 VEHICLE MOUNTED SPOTLIGHTS

MAKE THE SWITCH AND DISCOVER THE DIFFERENCE

MULTI DIRECTIONAL LIGHTING AT ANY ANGLE

TOGGLE BETWEEN LIGHTS TO CUSTOMIZE A BEAM PATTERN TO MATCH YOUR JOBSITE

CONTROL UP TO TWO NIGHTRAY 2 OR STARBEAM 2 WITH ONE CONTROLLER

EASILY ADD A SECOND NIGHTRAY 2 OR STARBEAM 2 SPOTLIGHT AT A LATER DATE

TOGGLES CONTROL BETWEEN TWO NIGHTRAYS OR STARBEAMS.

SWITCH BETWEEN SPOT AND FLOOD LIGHT FUNCTION FOR DUAL-FILAMENT NIGHTRAY MODELS.

URNS OFF LIGHT(S)

SHOWN AT ACTUAL SIZE: 8" X 2.75"

WIRELESS MODEL: 9704-87027



WIRED MODEL: 9704-87026



HANG OR CLIP CONTROLLER



KH INDUSTRIES

PROVIDING POWERFUL SOLUTIONS FOR OVER 60 YEARS



STARBEAM™ VEHICLE MOUNTED SPOTLIGHTS

BRIGHT DEPENDABLE ILLUMINATION IN A DURABLE DESIGN WITH WIRELESS CONTROL UP TO 100' AWAY



THESE RUGGED VEHICLE-MOUNTED SYSTEMS GENERATE FROM 720,000 TO 3-MILLION CANDLEPOWER OF LIGHT FROM TWIN ROTATING LAMP HEADS OFFERING 330° OF CONTROL IN BOTH THE HORIZONTAL AND VERTICAL AXES.

TWINRAY WIRELESS CONTROLLER WILL OPERATE EITHER ONE OR TWO STARBEAM 2 OR NIGHTRAY 2 SPOTLIGHTS INDEPENDENTLY FROM OVER 100'

MOTOR-DRIVEN DUAL LAMP HEADS ROTATE 330° (10°) ON HORIZONTAL AND VERTICAL AXES TO PROVIDE PRECISE PLACEMENT OF LIGHT OUTPUT

DURABLE DESIGN INCLUDES STAINLESS-STEEL LAMP HOUSING AND STAINLESS STEEL DRIVE SHAFTS

WEATHER RESISTANT POLYCARBONATE EXTERIOR HOUSING PROVIDES SAFE, DEPENDABLE OPERATION IN THE MOST DEMANDING ENVIRONMENTS

ILLUMINATION REDUNDANCY: DUAL LAMP HEADS PROVIDE NO SINGLE POINT OF FAILURE

WIRED CONTROLLER HAS NEW EASY-TO-INSTALL CAT5e CONNECTOR AND WEATHERPROOF HEAT SHRINK COVER 12 VDC STANDARD; 24 VDC AVAILABLE

Altec Model	KH Industries	Description
9706-03119	SB2-1H130-W	(2) LT-401 130 Watt, H3 Spot Lamps with TwinRay Wireless Controller, 720,000-cp total output, 12V
9706-01460	SB2-1D035-D	Wireless & Hardwired: (2) HID Xenon 35 Watt Lamps with TwinRay wireless and hardwired controller, automatic on/off switch, 1,200,000-cp total output, 12V
9706-01467	SB2-1H130-H	Hardwired: (2) LT-401 H3 Spot Lamps with TwinRay hardwired controller, 720,000-cp total output, 12V
Accessories and Replacement Bulbs		
9704-87027	NR2C-W	Additional TwinRay wireless controller
9706-03126	SB2C-H	Wired TwinRay Controller with 35' cable, dash-mount CAT5e connector & 6' coiled cord
9703-46665	KH200-00057	Replacement lamp for model LT401, Par 46 H3
9703-46666	KH200-00754	Replacement lamp for model LT433, 35W HID

Other models available, including 24V and higher lamp output options including emergency scene lighting and custom configurations.

LIGHTING EQUIPMENT

USA: 1-877-GO ALTEC
(1-877-462-5832)

www.alteconnect.com



KH INDUSTRIES
PROVIDING POWERFUL SOLUTIONS FOR OVER 60 YEARS



NIGHTRAY2™ WIRELESS SPOTLIGHT SYSTEM

THE LINEMAN'S SPOTLIGHT OF CHOICE

DESIGNED SPECIFICALLY TO MEET THE DAILY RIGORS OF THE UTILITY INDUSTRY, THE NIGHTRAY 2 SPOTLIGHT SYSTEM HAS BEEN REDESIGNED. THE NEW BASE AND CLUTCH HAVE BEEN FIELD TESTED TO WITHSTAND HEAVY VIBRATION IN THE ROUGHEST TERRAIN. ALL COMPONENTS ARE MADE WITH MARINE GRADE MATERIALS AND ARE SNOW, ICE, UV, AND SALTWATER RESISTANT.



FULL LAMP HEAD ROTATION: 370° OF MOTION ON HORIZONTAL AXIS AND 350° VERTICAL TILT
OPEN YOLK DESIGN ALLOWS FOR TROUBLE-FREE OPERATION IN SNOW AND ICE
DURABLE POLYCARBONATE EXTERIOR RESISTS BREAKAGE AND IS SNOW, ICE, UV, AND SALT WATER RESISTANT.

TWINRAY WIRELESS CONTROLLER WILL OPERATE EITHER ONE OR TWO STARBEAM 2 OR NIGHTRAY 2 SPOTLIGHTS INDEPENDENTLY FROM OVER 100'

CLEAR AND CONSISTENT NOISE FREE COMMUNICATION ON WIRELESS NIGHTRAY'S

WIRED CONTROLLER HAS NEW EASY-TO-INSTALL CAT5e CONNECTOR AND WEATHERPROOF HEAT SINK COVER

ELECTRICAL OPERATION: 12 VDC STANDARD; 24 VDC AVAILABLE

5 YEAR LIMITED WARRANTY*



LIGHTING EQUIPMENT

USA: 1-877-GO ALTEC
(1-877-462-5832)

www.alteconnect.com



KH INDUSTRIES

PROVIDING POWERFUL SOLUTIONS FOR OVER 60 YEARS





9704-91624 9704-91625 9704-91626 9704-91627 9704-87014 9704-84606 9704-87018 9704-87025

NIGHTRAY 2 SPOTLIGHT SYSTEM

LEGACY
NIGHTRAY

Light Package, Includes (1) NightRay Spotlight	Wireless TwinRay	Hardwired TwinRay	Wireless & Hardwired	2 Wireless TwinRay	Dash Mount Control Panel*
750,000-cp Total Output. Includes: One 50 Watt HID Spotlight with 750k-cp, 12V	9704-91624 NR4S-1D050-WS	9705-05179 NR4S-1D050-HS	9705-05161 NR4S-1D050-DS	9705-05167 NR4S-1D050-MS	9702-35252 NR955-20
360,000-cp Total Output. Includes: One H3 Spotlight with 360k-cp, 12V	9704-91625 NR4S-1H130-WS	9705-05178 NR4S-1H130-HS	9705-05160 NR4S-1H130-DS	9705-05166 NR4S-1H130-MS	8100-01061 775-20
200,000-cp Spot/50,000-cp Flood Total Output. Includes: One Par 46 Dual Filament Spotlight with 200k Spotlight/50k Flood light, 12V	9704-91626 NR4C-1C100-WS	9705-05177 NR4C-1C100-HS	9705-05162 NR4C-1C100-DS	9705-05165 NR4C-1C100-MS	7052-01715 675-20
100,000-cp Spot/50,000-cp Flood Total Output. Includes: One Par 36 Dual Filament Spotlight with 100k Spotlight/50k Flood light, 12V	9704-91627 NR3C-1C100-WS	9705-05176 NR3C-1C100-HS	9705-05163 NR3C-1C100-DS	9705-05164 NR3C-1C100-MS	0684-35038 475-20
Light Package, Includes (2) NightRay Spotlight	Wireless TwinRay	Hardwired TwinRay	Wireless & Hardwired	2 Wireless TwinRay	Dash Mount Control Panel*
1,500,000-cp Total Output. Includes: Two 50 Watt HID Spotlights with 750k-cp each and the TwinRay wireless controller, 12V	9704-87014 NR4S-1D050-WD	N/A	9705-05173 NR4S-1D050-DD	9705-05171 NR4S-1D050-MD	N/A
720,000-cp Total Output. Includes: Two H3 Spotlights with 360k-cp each and the TwinRay wireless controller, 12V	9704-84606 NR4S-1H130-WD	N/A	9705-05172 NR4S-1H130-DD	9705-05170 NR4S-1H130-MD	N/A
400,000-cp Spot/100,000-cp Flood Total Output. Includes: Two Par 46 Dual Filament Spotlights with 200k Spotlight/50k Flood light each and the TwinRay wireless controller, 12V	9704-87018 NR4C-1C100-WD	N/A	9705-05174 NR4C-1C100-DD	9705-05169 NR4C-1C100-MD	N/A
200,000-cp Spot/100,000-cp Flood Total Output. Includes: Two Par 36 Dual Filament Spotlights with 100k Spotlight/50k Flood light each and the TwinRay wireless controller, 12V	9704-87025 NR3C-1C100-WD	N/A	9705-05175 NR3C-1C100-DD	9705-05168 NR3C-1C100-MD	N/A

Customized NightRay packages are available with two different bulb configurations, contact Altec for pricing and model numbers.
* includes 20' wiring harness

ACCESSORIES	ALTEC	KH INDUSTRIES
Additional Wireless TwinRay Controller	9704-87027	NR2C-W
Hardwired TwinRay Controller w/35' cable, dash-mount CAT5e connector & 6' coiled cord	9704-87026	NR2C-H
Replacement 50 HID Spotlight	9703-46666	KH200-00754
Replacement Par 46 H3 Spotlight	9703-46665	KH200-00057
Replacement Par 46 Dual Filament Bulb	9703-42629	KH200-00059
Replacement Par 36 Dual Filament Bulb	7173-20205	KH200-134
Replacement or Additional NightRay 2 Spotlight		
NightRay 2 PAR46 Spot 50W HID 12V light only, no controllers	9705-88702	NR4S-1D050
NightRay 2 PAR46 Spot 130W H3 Halogen 12V light only, no controllers	9705-88703	NR4S-1H130
NightRay 2 PAR46 Spot/Flood 100W Incandescent 12V light only, no controllers	9705-88704	NR4C-1C100
NightRay 2 PAR36 Spot/Flood 100W Incandescent 12V light only, no controllers	9705-88705	NR3C-1C100

NightRay Spotlights are available in 24 VDC. Custom configuration is available, call Altec for more information.



KH INDUSTRIES
PROVIDING POWERFUL SOLUTIONS FOR OVER 60 YEARS



LIGHTING EQUIPMENT

USA: 1-877-GO ALTEC
(1-877-462-5832)

www.alteconnect.com

CLASS I DIVISION 1 LIGHTING FOR HAZARDOUS LOCATIONS

PORTABLE, INTRINSICALLY SAFE LED SPOTLIGHT AND WORK AREA LIGHT FOR CLASS I DIVISION 1 HAZARDOUS LOCATIONS

ON THE GO VERSATILITY: 340 DEGREE ROTATING HEAD WITH 70 DEGREE PIVOTING ANGLE FOR HANDS FREE INSPECTION, MAINTENANCE, AND REPAIR TASKS. SPECIFICALLY DESIGNED FOR PORTABLE TASK LIGHTING IN UNDERGROUND UTILITY OR PIPELINE INSPECTION AND MAINTENANCE



INTRINSICALLY SAFE DESIGN FEATURES:

10 HOUR RUN TIME

NO EXPOSED METAL

NO CHARGE CONTACTS; USES INDUCTION CHARGING

ONE-HAND RELEASE FROM CHARGING BASE

VERTICAL OR HORIZONTAL USE WITH ROTATING AND PIVOTING HEAD TO EASILY POSITION TOWARDS WORK AREA

TRIGGER-ACTIVATED FRONT LED LENS AND REAR SIGNAL LIGHTS

CERTIFIED AND LISTED FOR:

CLASS I DIVISION 1, GROUPS A, B, C & D

CLASS II, GROUPS E, F, & G

CLASS III, T4

cULus LISTED



REAR BLUE SIGNALING LIGHTS HAVE FIVE LIGHT PATTERNS: ON, OFF, FLASH, ROTATING AND SOS (FRONT & REAR)

FULL LANTERN PACKAGE:
405 LUMEN LANTERN,
CHARGING DOCK,
12 VDC AND 120 VAC
CHARGERS
P/N: 9703-46669

LAMP: LUXEON REBEL ES LEDS: 405 LUMENS WITH MEDIUM SPOT/FLOOD PATTERN
CHARGING: AC OR DC POWER SOURCES;
STEADY CHARGE; UP TO 8 HOURS
INCLUDED ACCESSORIES:
ADJUSTABLE CARRYING STRAP
120V CHARGER AND 12 VDC CHARGER WITH CHARGING DOCK
MOUNTING BRACKET

LIGHTING EQUIPMENT

USA: 1-877-GO ALTEC
(1-877-462-5832)

www.alteconnect.com

KH INDUSTRIES

PROVIDING POWERFUL SOLUTIONS FOR OVER 60 YEARS



Shield Mini Bar



- 17.63" L x 8.9" W x 2.94" T
- 10 High Intensity LED Light heads with 17 Flash Patterns
- Meets SAE J845 Class 1 and SAE J595

P/N 9703-32337 SHL10A Amber Lens with Amber LEDs Permanent Mount
 P/N 9703-32342 SHL10CA Clear Lens with Amber LEDs Permanent Mount
 P/N 9705-15542 SHL10CAW Clear Lens with Amber & White LEDs Permanent
 P/N 9703-32343 SHL10AM Amber Lens with Amber LEDs, 50 lb. Magnets
 P/N 9703-32352 SHL10CAM Clear Lens with Amber LEDs, 50 lb. Magnets
 P/N 9705-15543 SHL10CAWM Clear Lens with Amber & White LEDs, 50 lb. Magnets
 P/N 9703-32350 90LBMAG 90 lb. Magnet Kit
 P/N 9703-32362 SMKSMB Suction Magnet Kit

T-Rex Exterior Light



- 3 .85" L x 1.8" W x 1.34" D
- Extremely Bright with 6 LEDs per lighthead
- 27 user selectable flash patterns
- Synch up to 20 T-Rex light heads

P/N 9702-95623 TRX6A Torus Single Head, 6 LED's, Black Bezel, Flashing Amber
 P/N 9702-95633 TRX6W Torus Single Head, 6 LED's, Black Bezel, Flashing White
 P/N 9702-96867 TRX6AW Torus Single Head, 6 LED's, Black Bezel, Flashing Amber/White

CL199 Beacon



- 4.5" H x 6.5" D
- 12 Vertical LEDs in the body plus 12 Auxilliary LEDs in the top of the Beacon provide 360° Horizontal & 180° Vertical coverage

P/N 9701-74430 CL199AH 12/24 Volt, Permanent Mount Clear Lens with Amber LED's
 P/N 9702-96411 CL199AMH 12/24 Volt, Magnetic Mount Clear Lens with Amber LED's



LL400IASH Star Flash Strobe Beacon

- Polycarbonate Lens with State-of-the-Art Optics
- Amber Lens Standard. Red, Blue and Clear Lens Options Available. Green. Available in Tall Lens Only
- Field Replaceable Helix Strobe Tube
- Standard 1" Pipe Mount
- All Stainless Hardware
- 72 Quad-Flashes per Minute

- Heavy Duty Anodized Aluminum Base Minimizes Vibration and Heat
- Permanent or Magnetic Mount with 9 1/2' Coil Cord and Lighter Plug with On/Off Switch

P/N 0684-51137 LL400IASH Permanent Mount; Amber, Short Lens
 P/N 0684-51161 LL400IATH Permanent Mount; Amber, Tall Lens
 P/N 9703-32365 L400IASMH Magnetic Mount; Amber, Short Lens
 P/N 9706-37280 L400IATMH Magnetic Mount; Amber, Tall Lens

LED X™ Exterior Lights

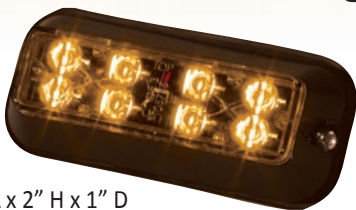

- 5" L x 2" H x 1" D
- Clear Lens with LEDs available in 4 Colors with Rust Proof Aluminum Housing
- Seven Flash Patterns

P/N 9700-14873 LXEXB1F-AH Single Head, Black Housing, Flashing, Amber, Directional Optic
 P/N 9703-32368 LXEXB1FW-AH Single Head, Black Housing, Flashing, Amber, Wide Optic
 P/N 9703-32372 LXEXB1F-WH Single Head, Black Housing, Flashing, White, Directional Optic
 P/N 9703-32374 LXEXB1FW-WH Single Head, Black Housing, Flashing, White, Wide Optic

XT3 NarrowStik Series



XT3 Exterior Lights



- 3.5" L x 1.3" H x 1" D
- Clear Lens with LEDs available in 5 colors
- Shock Resistant and Weather Protected

P/N 9703-32376 XT3AH Single Head, (3) LEDs, Black Housing, Flashing Amber
 P/N 9702-22689 XT3WH Single Head, (3) LEDs, Black Housing, Flashing White

- XT308: 28.6" Length
- 4 Amp Draw at Peak Input Current
- 12 Volt
- 5-Year Warranty on LEDs
- Meets SAE J595

P/N 9701-86675 XT308AS Amber



GOLIGHT®

Golight/RadioRay & Golight/RadioRay LED

NEW - LED Insert Available
370° Rotation x 135° Tilt
Portable or Permanent Mount
3 Year Limited Warranty
Wireless or Hard-Wired Remote Control



Stryker & Stryker H.I.D.

NEW - Available in Portable Mount
NEW - Available in H.I.D.
370° Rotation x 135° Tilt
Wireless or Hard Wired Remote Options
5 Year Limited Warranty



GXL

Multiple Illumination Options
Up to 7200 Lumen Output, 150,000 Candela
50,000 hr Life Expectancy
Instant On
Quick Adjust Mounting Cradle
Low Power Draw
Operating Temp Range -40° to 145° F
10 Year Limited Warranty



*Durable...
Powerful...
Versatile...
... Guaranteed!*



Golight /RadioRay Permanent Mount

Model 2000 - White, Wireless Handheld
Altec P/N - 7052-01491
Model 2020 - White, Wired Dash Remote
Altec P/N - 0684-35071

Golight/RadioRay Portable Mount

Model 7901 - White, Wireless Handheld
Altec P/N - 7173-30015

Golight RadioRay Accessories

P/N - 9703-36531 - LED Insert
P/N - 7173-30018 - Security Dome
P/N - 9701-93162 - Flood Lens Kit
P/N - 9000-01800 - Carrying Case
P/N - 7173-30034 - Wireless Dash Remote

Stryker & Stryker H.I.D. Permanent Mount

Model 3000 - White, Wireless Handheld
Altec P/N - 9701-05297
Model 30001 - White, Wireless Handheld H.I.D
Altec P/N - 9702-62822
Model 3100 - White, Wireless Dash Remote
Altec P/N - 9700-97437
Model 3067 - White, Dual Wireless Remotes
Altec P/N - 9700-51684

Stryker & Stryker H.I.D Portable Mount

Model 30002 - White, Wireless Handheld
Altec P/N - 9702-94235
Model 30003 - White, Wireless Hand Held H.I.D
Altec P/N - 9702-86894

Stryker Accessories

P/N - 7173-30034 - Wireless Dash Remote
P/N - 9700-81966 - Wireless Handheld Remote

**~NEW~
LED Models**

Golight /RadioRay Permanent Mount
Model 20004 - White, Wireless Handheld
Altec P/N - 9703-36536
Model 20204 - White, Wired Dash Remote
Altec P/N - 9703-36533

Golight/RadioRay Portable Mount
Model 79014 - White, Wireless Handheld
Altec P/N - 9703-36538

GXL
Model 4411 LED Spotlight
AltecP/N - 9703-36520
Model 4421 LED Floodlight
Altec P/N - 9703-36525





PELICAN™

LIGHTING EQUIPMENT

USA: 1-877-GO ALTEC
(1-877-462-5832)

www.alteconnect.com



9460 Remote Area Lighting System

- Using solid-state mounted LED's coupled with a thermally efficient light engine and our 1510 Pelican Protector™ Case, the RALS 9460 gives the user the ultimate maintenance free portable floodlight station
- Houses two of its light heads and it's multi-stage charger for that total self-contained convenience, and is equipped with a telescopic handle and rugged wheels for ease of transport.
- Comes with convenient low battery warning system and waterproof activation switch
- High Flux LED's with 50,000 expected hours; 6000 lumen (high), 3000 lumen (low)
- 2 Lampheads with 24 LEDs per head
- Battery- 40 hours runtime on low; 7 hours runtime on high
- 110 volt adaptor and international adaptor power leads included; 12-volt charger available

P/N 9703-66384 9460 Safety Yellow, 110V Charging System (12V Charging System Available)
 P/N 9703-09393 9460 Black, 110V Charging System (12V Charging System Available)

9430 & 9430 SL Remote Area Lighting Systems

- **9430 Models P/N 9702-43104 and P/N 9702-67996** each offer a wide 90° beam for large area coverage
- **9430SL Model P/N 9703-66385** each offer a Focused 10° beam with a 200 yard reach
- Impact-resistant polycarbonate lens
- Maintenance Free LED Array
- Life expectancy of 50,000 hours
- 110 Volt Charger Included; **12V charger available**
- Fully extendable mast with mast extension lock; 360 degree rotating head
- High Flux LED with 50,000 expected hours; 2000 lumens (low), 3000 lumens (high)
- Battery - 15 hours runtime on low; 8 hours runtime on high (will outlast the longest night of the year)
- Waterproof Rubber Activation Switch
- 1 Year Warranty

P/N 9702-43104



P/N 9703-66385

P/N 9702-67996

Model 9430 (Comes with 110V Charging Station - 12V System is Available):
 P/N 9702-43104 9430 Wide Beam, Safety Yellow (shown left)
 P/N 9702-67996 9430 Wide Beam, Black

Model 9430SL (Comes with 110V Charging Station - 12V System is Available):
 P/N 9703-66385 9430SL Focused Beam, Black (shown left)



9500 Shelter Lighting System

- Safe, secure, and silent LED interior shelter lighting in either red or white light
- Extremely rugged system is tested to a 3 meter drop-test, offering survivability not found in fluorescent lighting
- Light heads are linked and secured via hanging straps inside the temporary shelter
- Inline switch allows selection of light output color (red or white); each light head may be independently switched on or off
- Powered by the enclosed universal AC power supply or by an auxiliary 12-30 vdc power source such as the 9430 or 9460
- High Flux LED with 50,000 expected hours
- 1200 lumens (Red LED), 6000 lumens (White LED)
- 3 Lampheads with 36 LEDs per head (24 White/12 Red)
- 210° diffused beam spread
- RoHS (Restriction of Hazardous Substances) Compliant
- Complete Kit: 3 UV stable LED light heads, (3) 12' connector cables, hanging straps, power supply, and Pelican Protector Case

P/N 9704-24556 9500 Complete Kit

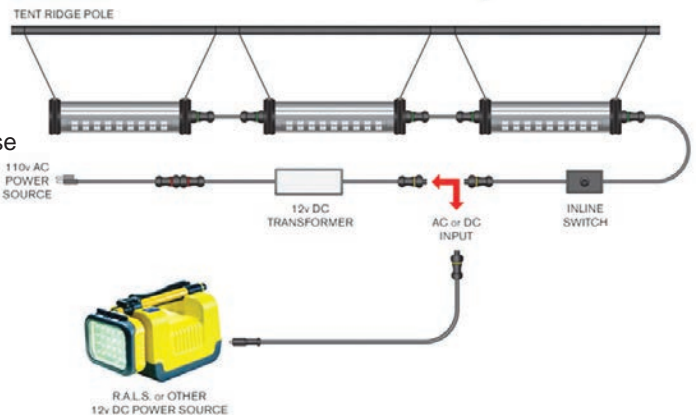

* Remote Area Lighting Systems feature a 1 Year Warranty



Pelican Products, Inc. guarantees its products (Exception: Remote Area Lighting Systems feature a 1 Year Warranty) for a lifetime against breakage or defects in workmanship. Pelican™ injection molded cases are guaranteed to be watertight to a depth of 3.3 feet (1 meter) for 30 minutes (IP 67) unless otherwise stated if properly closed with undamaged o-ring in place. Pelican's liability is limited to the case and not its contents or foam. This guarantee does not cover the lamp or batteries (rechargeable or disposable) for lights. Any liability, either expressed or implied, is limited to replacement of the product. This guarantee is void if the Pelican product has been abused beyond normal and sensible wear and tear. This guarantee does not cover shark bite, bear attack or damage caused by children under five.

* Remote Area Lighting Systems feature a 1 Year Warranty

StealthLite™ 2410 LED™ & 2410PL LED Photoluminescent Flashlight



P/N 9703-65010 2410 (left)
P/N 9702-67657 2410PL (right)

- P/N 9702-67657: Same features as the StealthLite 2410 LED Flashlight but outfitted with a lens ring that emits glow in the dark
- Photoluminescent material in the plastic absorbs the energy from any light source - fluorescent lights, sun, the flashlight's own beam
- Powered by 4 AA alkaline cells (included); 7.5 hour battery burntime, water and chemical resistant, 126 lumen output
- Class I II III Div. 1 Grps. ABCDEFG Operating Temp. Class T4
- Lifetime Guaranteed

P/N 9703-65010 2410
P/N 9702-67657 2410PL Photoluminescent Shroud

HeadsUp Lite™ 2690 Flashlight



- With 60 lumens of LED light, 10 hours of battery run time and weighing in at 4.1 ounces, it's brighter, more efficient, compact and lighter than other headlamps in its class

- Rotary bezel switch is easy to operate, even when wearing bulky gloves
- Impact, chemical resistant ABS; water resistant
- Features an adjustable and comfortable cloth strap, as well as a heavy duty rubber strap that will not slip off your climbing helmet
- 3 AAA Alkaline (Included); 10 hour battery run time
- II 1 D/G Ex ia IIC T4, Ex iaD 20 IP65 T65° C Certificate: TRL 08ATEX11184X and CL I, II, III, DIV1 GRPS ABCDEFG CL 1, Zone 0, Groups IIA, IIB, IIC SGS E1052012

P/N 9702-67986 2690

3610 Little Ed™ LED Flashlight



- Powered by 4 AA alkaline cells (included)
- 7.5 hour runtime
- 126 lumens, 6500 cd with 161m beam distance on high
- Water-proof and submersible
- 3610 uses Pelican's latest Deep Mount LED technology
- Made of tough ABS resin that corrosion proof and resistant to extreme temperatures

P/N 9703-66389 3610-Black Black Flashlight (Carded)
P/N 9703-66390 3610-Y Yellow Flashlight (Carded)
P/N 9703-66391 3610PL Recoil™ Flashlight w/ Photoluminescent Shroud

2360 LED Flashlight

- Aluminum w/Type II Anodized Body
- Powered by 2-AA Batteries (included)
- Runtime of 2 hours, 15 minutes
- Removable two way pocket clip
- Water-resistant
- High/Low light output is available (push of the tail button)
- Features a non-slip textured body for secure handling
- 6.2" Length
- 250 lumen (high), 24 lumen (low) with strobe feature



P/N 9703-66386 2360 Black

2760 LED Headlight

- Tough, lightweight, super bright and loaded with multiple lighting features that include high, low, flashing, downcast, and night vision red LED modes
- 133 lumens, 2 hour 15 minute runtime and 3415 cd with 117m beam distance (high); 90 lumens, 3.5 hour runtime and 1841 cd with 86m beam distance (low); 40 lumens, 14 hour runtime and 81 cd with 18m beam distance (downcast)
- Water-resistant



P/N 9706-41339 2760 Black

2720 LED Headlight

- Body Material: ABS
- Gesture Activation Control
- Variable Light Output
- Dual Red LED Night Vision
- Variable light output 100%-10%
- Signaling red (S.O.S) beacon light
- Gloved, wet, or oily hands are not an issue; turn on the light with a wave of a hand



- Low level red light preserves night vision, for nighttime applications
- Optical 4x magnification allows for a wide or penetrating beam
- 80 lumens, 8 hour runtime and 790 cd with 56m beam distance (high); 5 lumens, 175 hour runtime and 60cd with 15m beam distance (low)
- Water-resistant

P/N 9703-66388 2720 Black

9410L LED Lantern



- LESS THAN 3 LBS + 1131 LUMENS = BRIGHTEST & LIGHTEST IN ITS CLASS
- Four LEDs, powered by the latest generation Lithium-Ion batteries, illuminate a distance of 475 yards
- 120° rotating head
- Battery status indicator
- Run time: 9 hrs. (low)/3.75 hrs. (high)
- 3 mode switch (High, Low, Flashing)
- 8.75" L x 3.75" W x 4.0" H
- Shoulder strap included

P/N 9706-40794 9410L Safety Yellow, 110V
P/N 9706-40795 9410L Black, 110V

LIGHTING EQUIPMENT

USA: 1-877-GO ALTEC
(1-877-462-5832)

www.alteconnect.com

AIRCRAFT DYNAMICS™



LIGHTING EQUIPMENT

POLE TRANSPORTATION

USA: 1-877-GO ALTEC
(1-877-462-5832)

www.alteconnect.com

#1 Pole Transportation Safety System. Small and easy to store, yet extremely rugged with LED technology rated for 100,000 hours of heavy duty operation. Long range visibility of 5+ miles with four alternative flash patterns: Comet, Single, Steady Burn and Flare Flicker. Light modules are encapsulated for vibration and moisture resistance with front angled reflectors (front and side viewing). Easy to attach using a heavy duty strap that attaches to all poles. Additional features include powder coated metal components with dual flag holders. Powered by 3 alkaline C-cell batteries.

POLE BUG KIT



LED Strobe with Dual Flag Holder (shown):
 P/N 9701-54190 7015-R Red LED
 P/N 9701-86299 7015-A Amber LED

DUAL POLE BUG KIT



Dual LED Strobes with Dual Flag Holder:
 P/N 9701-86300 7026-R Red LED
 P/N 9701-86301 7026-A Amber LED

3 FLAG POLE BUG KIT



LED Strobe with Triple Flag Holder:
 P/N 9706-37379 7315-R Red LED
 P/N 9706-37380 7315-A Amber LED

CONE LIGHT KITS



Contains 4 lights in a crush proof case:
 P/N 9701-83193 7038-R 4 Red LED
 P/N 9701-86305 7039-A Amber LED

POLE TACKER KIT



Includes LED & T-screw & Batteries:
 P/N 9701-86317 7032-R Red LED
 P/N 9701-86318 7032-A Amber LED

AIRCRAFT DYNAMICS™



LIGHTING EQUIPMENT

360° LED strobes utilize 24 long lasting LEDs to create a highly visible 60 flashes per minute strobe. System is easy to attach and deploy, using a heavy duty strap that attaches to all types of poles and sizes. Strobe is protected by a rugged cage and includes powder coated metal components. Powered by 2 D cell alkaline batteries.

MID POLE 360



Mid Pole Strobes - Without Flags:
 P/N 9703-57286 7175-R Red LED
 P/N 9702-43402 7175-A Amber LED

STANDARD 360 KIT



Includes Flags & Batteries:
 P/N 9702-43401 7167-R Red LED
 P/N 9702-43264 7167-A Amber LED

3 FLAG 360 KIT



Includes Flags & Batteries:
 P/N 9706-37381 7360-R Red LED
 P/N 9706-37382 7360-A Amber LED

BOLT - THRU 360



BOLT - THRU W/ FLAGS 360



P/N 9706-37383 7219-R Red LED
 P/N 9706-37384 7219-A Amber LED

P/N 9706-37385 7177-R Red LED
 P/N 9706-37386 7177-A Amber LED

USA: 1-877-GO ALTEC
 (1-877-462-5832)

www.alteconnect.com

AIRCRAFT DYNAMICS™



LIGHTING EQUIPMENT

ROBO
S-TEG-
S

USA: 1-877-GO ALTEC
(1-877-462-5832)

www.alteconnect.com

NIGHT STALKER LED SCENE LIGHT

P/N 9706-37375 7002 Scene Light Only

P/N 9706-37376 5617 Combo Kit - Light, RoboPak & Charger

- 4 Heavy Duty 9 LED WorkLights
- 8,600 Total Lumens
- 12v 9amp operation
- Tough Waterproof Construction
- Aluminum Housing LED's
- Durable PMMA Lenses
- Operational Temp -40c to +60c
- Heavy Duty Stand w/ Adjustable Tripod
- Max Height - 12ft
- Nylon Carrying Bag included
- 1 year Warranty on parts and labor
- RoboPak - 12v 34aH

Overall Height:
12 Feet



Overall Height:
14 Feet

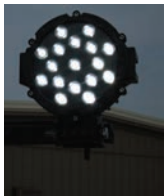

SUPER NIGHT STALKER LED SCENE LIGHT

P/N 9706-37377 7006 Scene Light Only

P/N 9706-37378 5611 Combo Kit - Light, RoboPak & Charger

- 2 Heavy Duty 13 LED WorkLights
- 7,400 Total Lumens
- 12v 13amp operation
- Tough Waterproof Construction
- Aluminum Housing LED's
- Durable PMMA Lenses
- Operational Temp -40c to +60c
- Heavy Duty Stand w/ Adjustable Tripod
- Max Height - 14ft
- 1 year Warranty on parts and labor
- RoboPak - 12v 34aH

GMP Pole Trailer Light Kits



- Features compact design, secure attachments and maximum visibility
- Allow easy transport of utility poles with greater visibility while meeting DOT requirements and only adding minimal width to the trailer
- Frame is made from an aluminum extruded weldment with a durable bright yellow polyester powder coating
- DOT approved lights and reflectors are mounted on the back and sides
- The kit uses a Reflexite label with 3" high lettering and a standard legend
- Shock mounts provide greater bulb life and simplify bulb replacement
- The unit comes with a 40' 18 gauge S.O. trailer cord with a heavy-duty 4-way or 6-way trailer plug
- The width of the unit is minimized with up-right flags and cordage storage arms located within the outer dimensions of the frame
- Attachment to the pole is done with an over-center chain binder that uses 5' of chain and hardened steel spikes that bury in the pole when the binder is tightened

Part Number	GMP	Description	Weight
9000-70274	70274	46" Wide; 4-way	26 lbs.
9000-70276	70276	46" Wide; 6-way	26 lbs.
9000-70277	70277	24" Wide; 4-way	14 lbs.
9000-70278	70278	24" Wide; 6-way	14 lbs.
9000-26006	26006	4-way Socket	2 oz.
9000-26007	26007	6-way Socket	2 oz.

Milwaukee BATTERY-POWERED LIGHTING

Nothing But HEAVY DUTY®

M18™ LED FLOOD LIGHT

- Up To 30% brighter than corded 250 halogen lights
- Up To 8 hours of run-time
- Limited Lifetime LED Warranty
- Innovative Roll Cage Design
- Multiple Hanging Features: EMT Hanger, Key Hole Hanger, Cross Bar Hanger, Handle Hanger
- Delivers up to 30% brighter light output than corded 250W halogen lights
- Designed to illuminate large workspaces on the jobsite, the cordless flood light uses 8 high-quality LEDs to provide 1,100 lumens and up to 1,300 lux
- Powered by the M18™ REDLITHIUM™ battery for up to 8 hours of runtime on a single charge
- Impact-resistant, replaceable lens
- it stands up to the toughest working conditions
- This compact flood light features an octagonal shape so the light may be used at multiple angles
- The versatile hanger provides hands-free use in a variety of application
- Carries a limited lifetime LED warranty.

P/N 9705-51242 2361-20

M18™ LED LIGHT

- REDLITHIUM™ Battery Technology: Superior pack construction, electronics, and performance deliver more work per charge and more work over pack life than any battery on the market
- Sealed aluminum head: Designed for impact- and weather-resistant durability
- 135° rotating head: Provides flexible, focused illumination
- Integrated hook: Leaves both hands free for work anywhere on the jobsite

P/N 9706-20113 2735-20



7" Round LED Headlamp



- When properly mounted, exceeds FMVSS-108 and CMVSS-108 requirements for low beam and high beam performance
- Excellent option for light, medium and heavy-duty trucks, off-road vehicles, classic cars, motorcycles and more
- Metalized reflector optics provide a lighting experience that's smooth and clean
- Provides a brighter, crisper and whiter light output, closer to the color temperature of daylight, dramatically improving light projection distance and overall visibility
- Military grade, die-cast aluminum housing and non-yellowing, polycarbonate lens offer optimum protection against damage from impact, roadside debris and other hazards
- Electronics are sealed in epoxy to resist from damage caused by corrosion
- Drop-in replacement for #6014, 6015, 6016, H6024 and Par 56 headlamp designs
- Uses standard, H4, 3-blade wiring connector

Altec P/N	Truck-Lite	Description
970346637	27270C	7" Round LED Headlamp, Multi-Volt

5"x7" Rectangular LED Headlamp



- When properly mounted, exceeds FMVSS-108 and CMVSS-108 requirements for low beam and high beam performance
- Excellent option for light, medium and heavy-duty trucks, off-road vehicles, classic cars, motorcycles and more
- Metalized reflector optics provide a lighting experience that's smooth and clean
- Provides a brighter, crisper and whiter light output, closer to the color temperature of daylight, dramatically improving light projection distance and overall visibility
- Military grade, die-cast aluminum housing and non-yellowing, polycarbonate lens offer optimum protection against damage from impact, roadside debris and other hazards
- Electronics are sealed in hardened epoxy to resist from damage caused by corrosion
- Drop-in replacement for #6052, 6053, H6054 and HP6054 headlamp designs
- Uses standard, H4, 3-blade wiring connector

Altec P/N	Truck-Lite	Description
970346638	27450C	5"x7" Rectangular LED Headlamp, Multi-Volt

81 Series 7" Round LED Auxiliary Lamp



- Two mounting options: one with an integrated mount and one designed for use with a secondary mounting bracket
- Spot pattern provides a targeted beam to brightly illuminate your specific area of interest
- Work light pattern provides a generous targeted beam to brightly illuminate your entire work area
- Flood light provides a wide lighting pattern for applications requiring a broadly cast pattern
- 1,300 Lumen output

Altec P/N	Truck-Lite	Description
970335503	81701	Spot Lamp, 12V
970346639	81711	Spot Lamp, Intgrtd. Mount, 12V
970277131	81702	Work Lamp, 12V
970322062	81712	Work Lamp, Intgrtd. Mount, 12V
970346640	81704	Flood Lamp, 12V
970346641	81714	Flood Lamp, Intgrtd. Mount, 12V

Signal-Stat Series LED Auxiliary Lamp



- Work pattern is ideal for off-road applications
- Operate from 9-36 volts without adjustment
- 8 diode pattern designed at 9-36v, 8w, 500-580 lumens
- 10 diode pattern designed at 9-36v, 10w, 750 lumens
- 9 diode pattern designed at 12-36v, 17.8w, 950 lumens

Altec P/N	Truck-Lite	Description
970346642	8150	4" Round 8 Diode
970346643	8155	4" Rectangular 8 Diode
970325501	8160	4" Rectangular 10 Diode
970324510	8170	5" Rectangular 9 Diode

Makita

INDUSTRIAL TOOLS

LXT[®]

LITHIUM-ION

70+ TOOLS



30 MINUTE CHARGE TIME

ONE BATTERY

LIGHTING EQUIPMENT

MAKITA 18V LXT[®] Lithium-Ion Cordless Flashlight

- Runs 4 Hours Per Charge
- High illumination Xenon bulb emits at 4,500 Lux
- 4-position head pivots for greater versatility
- Compact design at only 11-1/8" long and weighs just over 2 lbs.
- Soft grip handle provides increased comfort
- 1-year warranty on flashlight
- Battery and charger sold separately

P/N 9705-88755 BML185 Flashlight Only
 P/N 9702-16519 BL1830 Lithium Battery



P/N 9702-16519 BL1830



P/N 9705-88755 BML185



P/N 9705-88757
LXLM04

18V LXT[®] Lithium-Ion Cordless L.E.D. Flashlight

- High-luminance single L.E.D. flashlight provides 200 lumens
- 12 position pivoting flashlight head with positive stops from 60 - 110 degrees
- Aluminum flashlight head design for increased durability
- Metal hang hook is convenient and jobsite durable
- Up to 13 hours of continuous illumination on a single charge
- Multi-faceted reflector controls the direction and spread of the light casted by the L.E.D. and provides a sharp, round spotlight
- Compact design at only 10-3/4" long and weighs only 2.1 lbs. (with battery, sold separately)
- New redesigned rubberized soft grip provides increased comfort on the job
- 1-year warranty on flashlight

P/N 9705-88757 LXLM04 Flashlight Only
 P/N 9702-16519 BL1830 Lithium Battery



P/N 9702-16519 BL1830

18V LXT[®] Lithium-Ion Cordless 12 L.E.D. Flashlight

- High-luminance single L.E.D. flashlight provides 200 lumens
- 12 position pivoting flashlight head with positive stops from 60 - 110 degrees
- Aluminum flashlight head design for increased durability
- Metal hang hook is convenient and jobsite durable
- Up to 13 hours of continuous illumination on a single charge
- Multi-faceted reflector controls the direction and spread of the light casted by the L.E.D. and provides a sharp, round spotlight
- Compact design at only 10-3/4" long and weighs only 2.1 lbs. (with battery, sold separately)
- New redesigned rubberized soft grip provides increased comfort on the job
- 1-year warranty on flashlight

P/N 9705-88756 LXLM03 Flashlight Only
 P/N 9702-16519 BL1830 Lithium Battery



P/N 9702-16519 BL1830

P/N 9705-88756
LXLM03



USA: 1-877-GO ALTEC
(1-877-462-5832)

www.alteconnect.com

REFLECTIVE LAMPS

Truck-Lite 10 Series Reflectorized Marker & Clearance Lamp



- Lens & housing are sonically sealed
- High impact polycarbonate construction
- 12 volt 15,000 hour rated bulb life
- 15,000 hour rated 12v bulb life
- 12v designed at 14v, .33 amp, 2 cp
- 24v designed at 28v, .17 amp, 3 cp

P/N 684-21016 10205R Red, 2 1/2" Diameter; 12v

Truck-Lite Model 40 4" Sealed Lamp



- Polycarbonate lens & housing are vibration sealed
- Bulb is shock mounted for extended life
- Legal only for back-up function
- Not recommended for dome lamp use

P/N 7011-10017 40204 Clear, 12V

Truck-Lite 30 Series Marker & Clearance Lamp



- Wabash & Monon replacement
- "ABS" version complies with FMVSS 108 requirement for ABS malfunction indicator lamp on trailer and ABS

- braking systems
- 12 volt 15,000 hour rated bulb life
- Lamp designed for PC requirements on a 45° angle

P/N 684-21034 30200R Red, 2" Diameter; 12v

P/N 684-21044 30200Y Yellow, 2" Diameter; 12v

HOTLINE LIGHTING

LitLink



- By connecting it with any hot stick tool, the LitLink's high intensity LED provides lighting for work in dark or dimly lit areas
- Fits all major hot sticks and tools with splined universal slotted connector
- Weighs only 7 oz.
- Works with most universal tool accessories

P/N 9700-59056

LitFinger



- For use in hot stick operations in dark or unlit areas
- Increases visibility, making work on fuse barrels, cutouts, switches and disconnects safer and more efficient
- Lightweight, durable, and virtually

indestructible, even in extreme temperatures and conditions

P/N 9000-96192

BEACONS

Strobe Beacon with Universal Mounting Base



- Versatile and tough strobe with universal anodized aluminum mounting base.
- 5 1/2" lens provides greater visibility
- Accommodates surface, pipe, or magnetic mount options

P/N 684-51069 Strobe beacon

P/N 9000-88858 Replacement bulb

Single Flash Strobe Beacon with Heavy Duty Xenon Flash Tube



- 1/2" cast aluminum case, anodized aluminum case
- Heavy-duty Xenon flash tube
- 2.5 amps, 12 volts DC
- Dimensions: 7.75" high x 6" diameter
- Meets SAE requirements

P/N 684-51013 Strobe beacon

Rotating Halogen Beacon



- Built to withstand the toughest of conditions
- Rugged construction and corrosion resistant materials make this a light for the long term
- Meets SAE J845 Class 1 requirements
- Dimensions: 7.5" high x 8.5" diameter
- 35,000 candelas
- 4.7 amps

P/N 684-51003 Halogen beacon

P/N 9700-04250 Replacement bulb

P/N 8939-43170 Branch guard for P/N 684-51003, P/N 8939-14080

COMPARTMENT & ROPE LIGHTING

LED Compartment Lighting

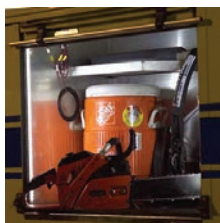

- Super bright, efficient white lighting
- 24 LEDs per 12" long section
- Draws 80% fewer amps than incandescents
- Rated average working life: 100,000 hours
- LEDs are safe to touch and exceed NFPA standard
- Withstand road vibration and shock better than halogens

- Full voltage range of 9.3 to 14 VDC
- Includes instructions, screws, male and female pigtail harnesses

P/N 9705-16703 24" LED Strip with 1" on Each End
 P/N 9700-89517 36" LED Strip with 1" on Each End
 P/N 9705-16701 48" LED Strip with 1" on Each End

Rope Lighting



- Rope lighting luminates truck compartments for easier visibility and is mounted inside the compartment
- Available in any length (sold per foot)

P/N 608-20003

MOUNTED LIGHTING

Permanent Mount Lights



- Features a rustproof deck mount with an adjustable bracket
- Replaceable halogen sealed beam
- Most frequently used by line service equipment and public utilities
- Dimensions: 6" x 7.8"
- Base dimension of 3.25"

P/N 684-35035 Floodlight, Honeycomb Lens
 P/N 684-35036 Spotlight, Clear Lens

Magnet Mount Light



- This handy and rugged magnet mount light lets you position your light allowing you to work with both hands in its bright light beam
- Features two light elements
- Has a nominal 100,000 candle power beam and 90 lb. magnet
- High durability rubber elastomer casing is impervious to hydraulic and automotive oils
- Light head and yolk are shock resistant
- Includes bulb guard and 10' power cord

P/N 9000-21500

POLE END LIGHTING

Pole End LED Light Bar

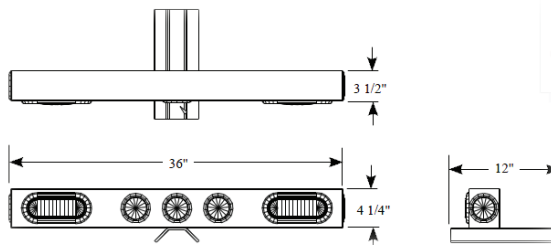

- Extremely rugged but light weight aluminum construction (about 17 lbs.)
- Includes all the lights normally found on the rear of a trailer, including stop/turn rear-facing marker lights and side marker lights.
- A 5000 lb 2" wide nylon ratchet strap securely fastens the light bar to any diameter pole
- Extends all the legally required lights to the end of your poles.
- 2" wide 5000 lb test ratchet and nylon strap for secure and flexible mounting
- Sealed, shock resistant, LED lights.
- 30' of cable
- Flag holders
- LED Lights

P/N 9702-66465

LIGHTING EQUIPMENT

USA: 1-877-GO ALTEC
(1-877-462-5832)

www.alteconnect.com

MISCELLANEOUS LIGHTING

1,250,000 CP Mighty Hand-Held Light



- Portable hand-held lights light up even the darkest of work areas
- 1,250,000 candle power, spot only
- Tough aircraft aluminum construction with 9' cigarette lighter cord
- Uses 100 watt H-1 spot bulb

P/N 9000-21910 Momentary

750,000 CP Mighty Hand-Held Light



- 750,000 candle power, dual stage
- Momentary rocker switch for spot or flood
- 100 watt H-2 spot bulb draws 7.8 amps; 55 watt H-2 flood bulb draws 4.3 amps
- Constructed from impact-resistant polycarbonate

P/N 9000-21990 Momentary

Decklight



- 30-watt decklight
- Heavy-duty chrome finish
- Rotates 360° horizontally and 180° vertically
- 50,000 candlepower with up to 100 hours of lamp life
- 5" spot
- Dimensions: 5.6" x 7.8"
- Base diameter of 3.0"

P/N 684-35003 Decklight
P/N 9000-04405 Replacement bulb

Halogen Sequential Traffic Indicator



- Wide angle lens provides warning in all directions
- Standard controls offer left, right, center-out, and flashing warning patterns
- Solid state LED control module 3" w x 2.75" h
- 8 lamp directional light with 30' cable
- Sturdy aluminum housing designed to block sunlight
- 42" in length

P/N 684-55010

Genesis Spotlight/Floodlight



- 1 hour spot and 6 hours flood run time with 8 hours recharge time
- Polycarbonate construction
- Removable handheld light
- 7.0 amp-hour battery with DC charge connector
- 3 position rocker switch standard

P/N 9700-81629
P/N 9700-81631 9' coiled cord

Versalite™ Model C Dual Beam Light



- 50,000/100,000 cp spotlight features a 12' straight cord that plugs into a cigarette lighter or other 12 volt power source
- 3 way switch for floodlight or spotlight
- 100 lb. "pull" magnet with mylar shield keeps unit in place on ferrous metal surfaces in any position

P/N 9701-14286 050-BG36

Streamlight Nano Light



- Micro-miniature key chain light is just 1.47" long
- Rotating on/off head switch
- Includes (4) IEC-LR41 coin cells
- Machined aircraft aluminum construction
- Up to 8 hours of declining usable output
- White LED delivers up to 10 lumens
- Non-rotating snap hook for easy one-handed operation
- Parabolic shaped LED area optimizes beam performance

P/N 9701-31480 73001

Golight Profiler II



- Lithium-ion rechargeable spotlight
- Precision, pressure cast, aircraft aluminum
- Exclusive NxT BlueFusion technology
- 115vAC charger and 12v direct run cord
- 12vDC docking station charging system
- 55w 4000K high color temperature blue vision searchlight beam; 1 watt LED convenience beam
- Dual light sources - searchlight (60 min. run time) or LED convenience beam (50+ hour run time); 2 hour recharge time

P/N 9700-89224

Klein Grips

Klein Grips

- Equipped with chain, toggle and shackle
- For support wire .134 and larger, use P/N 9000-16596
- Outside diameter of support wire includes thickness of polyethylene coating

Part Number	Klein	Capacity	Jaw Length	Maximum Safe Load	Weight
P/N 9000-16597	1684-5AT	.218" - .55" cable	5"	8000 lbs.	6.25 lbs.

(Identical to Bell-System type "L" strand puller)



Klein Chicago Grip for Bare ACSR, Aluminum, and Stranded Copper Cables

- Round, smooth inside jaw contour on this series of grips is ideal for bare ACSR, aluminum, and stranded copper cables
- Smooth jaws grip with maximum contact and are less likely to damage conductors

PART NUMBER	MODEL	WIRE SIZE	CAPACITY
P/N 9000-16562	1656-20	.20" x .40"	4500 lb. capacity
P/N 9000-16563	1656-30	.31" x .53"	4500 lb. capacity
P/N 9000-16564	1656-40	.53" x .74"	8000 lb. capacity
P/N 9000-16565	1656-50	.74" x .86"	8000 lb. capacity
P/N 9700-89413	1656-60	.86" x .53"	8000 lb. capacity



Klein Grips for Bare Wire



- A lightweight grip for working with solid and stranded bare wire from .08" to .20"
- Simple three-point jaws designed for use on small-diameter bare wire and cable
- Single "V" groove jaw
- Maximum safe load is 1,500 lbs.

P/N 9000-88912 Klein 1613-30 0.08" x 0.20"

Klein Curved-Jaw Grips for EHS Cable



- When pulling EHS (extra-high-strength) galvanized-steel cable, the galvanizing has a tendency to coat the jaws of any grip, causing the cable to slip; to reduce the possibility of slippage and damage to the cable, the jaws of this grip are milled on a curve with a double "V" contour
- Maximum safe load is 8,000 lbs.

P/N 9000-16847 Klein 1684-74 0.218" x 0.55"

KLEIN TOOLS®



Committed to manufacture the highest quality hand tools with unmatched durability and comfort for over 155 years

GRIPS, HOISTS, & RIGGING

USA: 1-877-GO ALTEC
(1-877-462-5832)

www.alteconnect.com

Grips for Weatherproof Wire



- Round jaws provide maximum contact and gripping power to minimize conductor damage
- Notches in jaw provide firm grip on insulation
- Round inside jaw contour for weatherproof coated wire
- Maximum safe load for P/N 9000-16112 and P/N 9000-16113 is 4,500 lbs.
- Maximum safe load for P/N 9000-16114 and P/N 9000-16115 is 8,000 lbs.

Note: Due to various types of weatherproof coatings available, selection of proper grips is determined by outside diameter of cable.

P/N 9000-16112	Klein 1611-20	0.20" x 0.40"
P/N 9000-16113	Klein 1611-30	0.31" x 0.53"
P/N 9000-16114	Klein 1611-40	0.53" x 0.74"
P/N 9000-16115	Klein 1611-50	0.78" x 0.88"

Grips for PVC-Covered Conductors



- The serpentine jaws of this grip series are specially machined to allow insertion of insulated conductors through the jaws, which reduces danger of slippage which might result in insulation damage
- Round inside-jaw contour
- Maximum safe load for P/N 9000-16592 and P/N 9000-16593 is 4,500 lbs.
- Maximum safe load for P/N 9000-16594 and P/N 9000-16595 is 8,000 lbs.

P/N 9000-16594 Klein 1659-40 0.49" x 0.79"

Grips for Extra-High-Strength Cables, Messenger, Guy Strand & Conductors



- A family of grips for cable sizes from 0.12" to 1.0"
- Double "V" grooves give four-point contact, reducing chance of slipping and providing proper alignment
- For larger conductors, see our grips with round inside-jaw contour
- Maximum safe load for P/N 9000-16134 is 4,500 lbs.
- Maximum safe load for P/N 9000-88910, P/N 9000-16925, and P/N 9000-16846 is 8,000 lbs.
- Maximum safe load for P/N 9000-16281, P/N 9000-16287 and P/N 9000-16288 is 15,000 lbs.

P/N 9000-16134	Klein 1613-40	0.12" x 0.37"	P/N 9000-16287	Klein 1628-17	0.50" x 0.75"
P/N 9000-88910	Klein 1684-5	0.218" x 0.55"	P/N 9000-16288	Klein 1628-18	0.75" x 1.00"
P/N 9000-16925	Klein 1692-5	0.218" x 0.55"			
P/N 9000-16846	Klein 1684-5F	0.16" x 0.55"			
P/N 9000-16281	Klein 1628-16	0.31" x 0.62"			

Klein Haven (Bull Dog) Grips



P/N 9000-88895 P/N 9000-16042 P/N 9000-16252
P/N 9000-16041

- Designed for use when light, compact grip is desired and where conductor damage is not a factor
- Gripping pressure of the knurled jaw is applied to 1/4" cable area
- P/N 9000-16042 features a swing latch to help hold cable in the jaw

PART NUMBER	MODEL	WIRE SIZE	CAPACITY
P/N 9000-16041	1604-10	.06" x .25"	2500 lb. capacity
P/N 9000-16042	1604-20L	.125" x .50"	5000 lb. capacity
P/N 9000-88895	1604-20	.125" x .50"	5000 lb. capacity
P/N 9000-16252	1625-20	.28" x .75"	8,000 lb. capacity

Klein Parallel Jaw Grips

- Longer jaws achieve a firm hold, reducing possibility of slippage
- Design includes a latch, plus a large diameter eye that accommodates large hooks on hoists, winches and tackle blocks

PART NUMBER	MODEL	WIRE SIZE	CAPACITY
P/N 9000-16711	1671-10	.37" x .75"	10,000 lbs.
P/N 9000-16712	1672-10	.37" x .75"	10,000 lbs.
Features knurled jaws			
P/N 9000-88911	1685-20	.157" x .886"	4,500 lbs.
Features round inside jaw contour and serrated lower jaw			
P/N 9000-16853	1685-31	.625" x 1.250"	7,500 lbs.
Features round inside jaw contour and serrated lower jaw			
P/N 9000-16861	1686-10	.20" x .40"	10,000 lbs.



P/N 9000-16711
P/N 9000-16861



P/N 9000-88911



P/N 9000-16712



P/N 9000-16853

Klein Wire Pulling Grips



P/N 9702-69935 Kit

Includes (1) of Each:

P/N 9702-66356 KT4800

P/N 9702-66351 KT4600

P/N 9702-43560 KT4500

KT4500 Series Parallel-Jaw Grips

Cable Range from .180" to .600"

- P/N 9702-43561 and P/N 9702-43574 are supplied with hot latches
- 5,000 lbs. maximum safe load

Part Number	Size	Features
P/N 9702-43560	KT4500	Spring
P/N 9702-43561	KT4501	Hot Latch, Spring, Locking Handle
P/N 9702-43574	KT4502	Hot Latch Only

KT4600 Series Parallel-Jaw Grips

Cable Range from .300" to .800"

- P/N 9702-66352 and P/N 9702-66356 are supplied with hot latches
- 10,000 lbs. maximum safe load

Part Number	Size	Features
P/N 9702-66351	KT4600	Spring
P/N 9702-66352	KT4601	Hot Latch, Spring, Locking Handle
P/N 9702-66355	KT4602	Hot Latch Only

KT4800 Series Parallel-Jaw Grips

Cable Range from .700" to 1.25"

- P/N 9702-66357 and P/N 9702-66368 are supplied with hot latches
- 12,000 lbs. maximum safe load

Part Number	Size	Features
P/N 9702-66356	KT4800	Spring
P/N 9702-66357	KT4801	Hot Latch, Spring, Locking Handle
P/N 9702-66368	KT4802	Hot Latch Only

KLEIN TOOLS®



Committed to manufacture the highest quality hand tools with unmatched durability and comfort for over 155 years

Klein Grips

Chicago® Grip -- Dual Conductor Transmission

- Designed specifically for VR2® (vibration-resistant) and TransPowr® T-2® dual conductor twisted pair cables.
- Machined upper and lower jaws eliminate scoring or damage to second conductor by contouring to second conductor.
- Round jaws shaped to provide maximum contact with circumference of cable and prevent cable deformation.
- Supplied with spring and locking loop handles, allows jaws to be held in open position for easier placement on cable.
- Grips maintain temporary tension until the wire or cable can be permanently terminated.
- Also for use on aluminum, copper, weatherproof coated wire and PVC covered conductors
- Available in U size. Made to order sizes also available
- Each grip is made for one size cable only
- VR2 is a registered trademark of Southwire Company
- TransPowr and T-2 are registered trademarks of General Cable Technologies Corporation
- Orders must specify exact outside diameter of cables, circular mills with strand combination, or manufacturer's code

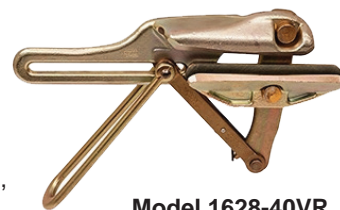

Model 1628-40VR

P/N 9706-47510 1628-40VR U SIZE*

* Made to order sizes are available:

Please Call 1-877-GO ALTEC (1-877-462-5832) with the exact outside diameter of cables, circular mills with strand combination, or manufacturer's code. Grips are made to specifications; therefore, these are special order items and non-returnable.

Warnings

CAUTION:

- (1) Proper maintenance and field inspection of all grips is necessary before each use
- (2) Check to be sure there is no accumulation of foreign material in the jaws which might cause slippage
- (3) Check mechanical condition of entire grip
- (4) Check grip to be sure it is the correct size and type for the application
- (5) Check and lubricate; DO NOT lubricate gripping surfaces of jaws
- (6) Check all parts for distortion or misalignment

WARNING: Before each use clean jaw area and inspect grip for proper operation to avoid slippage

WARNING: When used on/or near energized lines, ground, insulate, or isolate grip before pulling

WARNING: Do not exceed rated capacity

WARNING: Always match proper size and type grip to application

WARNING: Grips are to be used for temporary installation not permanent anchorage

Hoist

KN1500P-EX Web-Strap Ratchet Hoist

- Large, non-conductive dial (drum knob) allows web slack to be adjusted with ease
- 360° handle rotation
- 3/4 ton single line and 1-1/2 ton double line load rating
- Tight ratcheting mechanism allows precise tensioning
- Meets ANSI/ASME B30.21-2005 and B30.10-2009 standards

Single Line

Load rang: 1500 lbs. (675 kg)

Pulling distance: Max 138" (3500 mm)

Min 20" (500 mm)

Double Line

Load rang: 3000 lbs. (1350 kg)

Pulling distance: Max 79" (2000 mm)

Min 26" (700 mm)

Weight 12.5 lbs.

P/N 9000-16041 KN1500P-EX



ACSS/TW (Aluminum Conductor Steel Supported/Trapezoidal Wire)

For Cable Diameter

795 - 2627.3 MCM

.960" - 1.762" (24.38 mm - 44.75 mm)

25,000 lbs.
with bolt on jaw

MCM Cable Size	Diameter inches (mm)	No. of Alum. & Steel Strands	Code Word	Cat. No
795 MCM	.960" (24.38 mm)	17 x 7	Tern/ACSS/TW	1628-50P*
768.2 MCM	.977" (24.82 mm)	20 x 7	Maumee/ACSS/TW	1628-50P*
795 MCM	.980" (24.89 mm)	18 x 7	Puffin/ACSS/TW	1628-50P*
795 MCM	.993" (25.22 mm)	20 x 7	Condor/ACSS/TW	1628-50P*
762.8 MCM	.990" (25.15 mm)	20 x 7	Wabash/ACSS/TW	1628-50P*
795 MCM	1.010" (25.65 mm)	20 x 7	Drake/ACSS/TW	1628-50P*
954 MCM	1.049" (26.64 mm)	30 x 7	Phoenix/ACSS/TW	1628-50R*
957.2 MCM	1.060" (26.92 mm)	32 x 7	Kettle/ACSS/TW	1628-50R*
954 MCM	1.061" (26.94 mm)	32 x 7	Rail/ACSS/TW	1628-50R*
946.7 MCM	1.077" (27.36 mm)	35 x 7	Fraser/ACSS/TW	1628-50R*
954 MCM	1.084" (27.53 mm)	20 x 7	Cardinal/ACSS/TW	1628-50S*
1033.5 MCM	1.089" (27.66 mm)	30 x 7	Snowbird/ACSS/TW	1628-50S*
966.2 MCM	1.092" (27.73 mm)	21 x 7	Columbia/ACSS/TW	1628-50S*
959.6 MCM	1.108" (28.14 mm)	22 x 7	Suwannee/ACSS/TW	1628-50S*
1033.5 MCM	1.102" (27.99 mm)	32 x 7	Ortolan/ACSS/TW	1628-50S*
1033.5 MCM	1.129" (28.68 mm)	21 x 7	Curlew/ACSS/TW	1628-50S*
1113 MCM	1.129" (28.68 mm)	30 x 7	Avocet/ACSS/TW	1628-50S*
1113 MCM	1.143" (29.03 mm)	33 x 7	Bluejay/ACSS/TW	1628-50T*
1168.1 MCM	1.155" (29.34 mm)	30 x 7	Cheyenne/ACSS/TW	1628-50T*
1158 MCM	1.165" (29.59 mm)	33 x 7	Genessee/ACSS/TW	1628-50T*
1192.5 MCM	1.167" (29.64 mm)	30 x 7	Oxbird/ACSS/TW	1628-50T*
1192.5 MCM	1.181" (29.99 mm)	33 x 7	Bunting/ACSS/TW	1628-50T*
1113 MCM	1.185" (30.10 mm)	38 x 19	Finch/ACSS/TW	1628-50T*
1158.4 MCM	1.196" (30.38 mm)	25 x 7	Hudson/ACSS/TW	1628-50T*
1272 MCM	1.203" (30.56 mm)	30 x 7	Scissortail/ACSS/TW	1628-50T*
1272 MCM	1.203" (30.56 mm)	30 x 7	Catawba/ACSS/TW	1628-50T*
1257.1 MCM	1.213" (30.81 mm)	35 x 7	Nelson/ACSS/TW	1628-50U*
1272 MCM	1.220" (30.99 mm)	35 x 7	Bittern/ACSS/TW	1628-50U*
1192.5 MCM	1.225" (31.12 mm)	38 x 19	Grackle/ACSS/TW	1628-50U*
1233.6 MCM	1.245" (31.62 mm)	38 x 19	Yukon/ACSS/TW	1628-50U*
1371.5 MCM	1.248" (31.70 mm)	30 x 7	Truckee/ACSS/TW	1628-50U*
1351.5 MCM	1.256" (31.90 mm)	35 x 7	Dipper/ACSS/TW	1628-50U*
1272 MCM	1.264" (32.11 mm)	39 x 19	Pheasant/ACSS/TW	1628-50U*
1359.7 MCM	1.269" (32.23 mm)	36 x 7	Mackenzie/ACSS/TW	1628-50W*
1431 MCM	1.291" (32.79 mm)	36 x 7	Bobolink/ACSS/TW	1628-50W*
1467.8 MCM	1.292" (32.82 mm)	33 x 7	St. Croix/ACSS/TW	1628-50W*
1334.6 MCM	1.293" (32.84 mm)	39 x 19	Thames/ACSS/TW	1628-50W*
1351.5 MCM	1.300" (33.02 mm)	39 x 19	Martin/ACSS/TW	1628-50W*
1455.3 MCM	1.302" (33.07 mm)	36 x 7	Miramichi/ACSS/TW	1628-50W*
1569 MCM	1.334" (33.88 mm)	33 x 7	Platte/ACSS/TW	1628-50X*
1431 MCM	1.337" (33.96 mm)	39 x 19	Plover/ACSS/TW	1628-50X*
1433.6 MCM	1.338" (33.99 mm)	39 x 19	Merrimack/ACSS/TW	1628-50X*
1557.4 MCM	1.345" (34.16 mm)	36 x 7	Potomac/ACSS/TW	1628-50X*
1590 MCM	1.358" (34.49 mm)	36 x 7	Lapwing/ACSS/TW	1628-50X*
1533.3 MCM	1.382" (35.10 mm)	39 x 19	Rio Grande/ACSS/TW	1628-50X*
1657.4 MCM	1.386" (35.20 mm)	36 x 7	Schuylkill/ACSS/TW	1628-50X*
1590 MCM	1.408" (35.76 mm)	42 x 19	Falcon/ACSS/TW	1628-50Y*
1622 MCM	1.424" (36.17 mm)	39 x 19	Pecos/ACSS/TW	1628-50Y*
1758.6 MCM	1.427" (36.25 mm)	37 x 7	Pee Dee/ACSS/TW	1628-50Y*
1780 MCM	1.445" (36.70 mm)	37 x 19	Chukar/ACSS/TW	1628-50Y*
1730.6 MCM	1.465" (37.21 mm)	39 x 19	James/ACSS/TW	1628-50Z*
1949.6 MCM	1.504" (38.20 mm)	42 x 7	Athabaska/ACSS/TW	1628-50Z*
1926.9 MCM	1.545" (39.24 mm)	42 x 19	Cumberland/ACSS/TW	1628-50A*
2153.8 MCM	1.602" (40.69 mm)	64 x 19	Powder/ACSS/TW	1628-50B*
2156 MCM	1.608" (40.84 mm)	64 x 19	Bluebird/ACSS/TW	1628-50B*
2627.3 MCM	1.762" (44.75 mm)	64 x 19	Santee/ACSS/TW	1628-50D*

*Klein Tools recommends using the 1628-50 series grips for ACSS and ACSS/TW cable. Special order only. Application must be confirmed prior to ordering. Please allow 30 days for delivery. Jaw must be removed to insert cable.

GRIPS, HOISTS, & RIGGING

USA: 1-877-GO ALTEC
(1-877-462-5832)

www.alteconnect.com



Wire Sizing Index

Diameters, Stranding, & Ultimate Strength of ACSR and All-Aluminum Bare Cables

AWG or cmil Cable Size	Code Word	Number of Alum. & Steel Strands	Diameter	Ultimate Strength Diameter in Pounds Class A Galv Steel	Code Word	Number of Strands	Diameter	Ultimate Strength in Pounds
6	Turkey	6x1	.198"	1,190	Peachbell	7	.184"	563
4	Swan	6x1	.250"	1,860	Rose	7	.232"	881
4	Swanate	7x1	.257"	2,360	--	--	--	--
2	Sparrow	6x1	.316"	2,850	Iris	7	.292"	1,350
2	Sparate	7x1	.325"	3,640	--	7	--	--
1	Robin	6x1	.354"	3,550	Pansy	--	.328"	1,640
1/0	Raven	6x1	.398"	4,380	Poppy	7	.368"	1,990
2/0	Quail	6x1	.447"	5,300	Aster	7	.414"	2,510
3/0	Pigeon	6x1	.502"	6,620	Phlox	7	.464"	3,040
4/0	Penquin	6x1	.563"	8,350	Oxlip	7	.522"	3,830
266800 C.M.	Waxwing	18x1	.609"	6,880	Daisy	7	.586"	4,830
266800	Partridge	26x7	.642"	11,300	Laurel	19	.593"	4,970
300000	Ostrich	26x7	.680"	12,700	--	--	--	--
336400	Oriole	30x7	.741"	17,300	Tulip	19	.666"	6,150
336400	Linnet	26x7	.720"	14,100	--	--	--	--
397500	Lark	30x7	.806"	20,300	Canna	19	.724"	7,110
397500	Ibis	26x7	.783"	16,300	--	--	--	--
477000	Hen	30x7	.883"	23,800	Cosmos	19	.792"	7,360
477000	Hawk	26x7	.858"	19,500	Syringa	37	.795"	7,690
500000	Heron	30x7	.904"	24,950	Zinnia	19	.811"	8,760
500000	--	--	--	--	Hyacinth	37	.813"	9,110
556500	Eagle	30x7	.953"	27,800	Dahlia	19	.856"	9,750
556500	Dove	26x7	.927"	22,600	Mistletoe	37	.858"	9,940
600000	--	--	--	--	Meadowsweet	37	.891"	10,700
605000	Squab	26x7	.966"	24,300	--	--	--	--
605000	Peacock	24x7	.953"	21,600	--	--	--	--
636000	Egret	30x19	1.019"	31,500	Orchid	37	.918"	11,400
636000	Grosbeak	26x7	.990"	25,200	--	--	--	--
636000	Goose	54x7	.977"	23,300	--	--	--	--
666600	Flamingo	24x7	1.000"	23,700	--	--	--	--
715500	Redwing	30x19	1.081"	34,600	Violet	37	.974"	12,800
715500	Starling	26x7	1.051"	28,400	Nasturtium	61	.975"	13,100
715500	Crow	54x7	1.036"	25,900	--	--	--	--
795000	Mallard	30x19	1.140"	38,400	Arbutus	37	1.026"	13,900
795000	Drake	26x7	1.108"	31,500	Lilac	61	1.028"	14,300
795000	Condor	54x7	1.092"	28,200	--	--	--	--
874500	Crane	54x7	1.146"	31,000	Anemone	37	1.076"	15,000
874500	--	--	--	--	Crocus	61	1.077"	15,800
900000	Canary	54x7	1.162"	31,900	--	--	--	--
954000	Cardinal	54x7	1.196"	33,800	Magnolia	37	1.124"	16,400
954000	--	--	--	--	Godenrod	61	1.126"	16,900
1033500	Curlew	54x7	1.245"	36,600	Bluebell	37	1.170"	17,700
1113000	Finch	54x19	1.293"	39,100	Marigold	61	1.216"	19,700
1192500	Grackle	54x19	1.338"	41,900	Hawthorn	61	1.258"	21,100
1272000	Pheasant	54x19	1.382"	43,600	Narcissus	61	1.297"	22,000
1351500	Martin	54x19	1.424"	46,300	Colubine	61	1.339"	23,400
1431000	Plover	54x19	1.465"	49,100	Carnation	61	1.379"	24,300
1510500	Parrot	54x19	1.505"	51,700	--	--	--	--
1510500	--	--	--	--	Gladiolus	61	1.417"	25,600
1590000	Falcon	54x19	1.545"	54,500	Coreopsis	61	1.453"	27,000
80000	Grouse	8x1	.367"	5,200	--	--	--	--
101800	Petrel	12x7	.461"	10,400	--	--	--	--
110800	Minorca	12x7	.481"	11,300	--	--	--	--
134600	Leghorn	12x7	.530"	13,600	--	--	--	--
159000	Guinea	12x7	.576"	16,000	--	--	--	--
176900	Dotterel	12x7	.607"	17,300	--	--	--	--
190800	Dorking	12x7	.631"	18,700	--	--	--	--
203200	Brahma	16x19	.714"	28,400	--	--	--	--
211300	Cochin	12x7	.664"	20,700	--	--	--	--

GRIPS, HOISTS, & RIGGING

USA: 1-877-GO ALTEC
(1-877-462-5832)

www.alteconnect.com



COFFING[®] HOISTS

by Columbus McKinnon



GRIPS, HOISTS, & RIGGING

USA: 1-877-GO ALTEC
(1-877-462-5832)

www.alteconnect.com

Standard Spring-Loaded Grips



P/N 9000-04500 &
P/N 9700-43133

P/N 9700-47914

- Handle eye opening 1.25" x 1.75"
- Accept standard hooks and easily attach to tackle blocks
- Forged steel construction with yellow chromate finish to protect from rust and corrosion

PART NUMBER	LITTLE MULE	CAPACITY	WIRE SIZE/GAUGE
P/N 9000-04500	LMG4500	5,000 lbs.	.18" - .60" (6AWG - 4/0AWG)
P/N 9700-43133	LMG4600	10,000 lbs.	.30" - .80" (1AWG - 450MCM)
P/N 9700-47914	LMG4800	12,000 lbs.	.70" - 1.25" (397MCM - 1130MCM)

Hot Line Spring Loaded Grips, Notched Handles



P/N 9700-62695 &
P/N 9700-80827

P/N 9700-60000

- Hot Line Models also feature spring loaded gate with locking mechanism

PART NUMBER	LITTLE MULE	CAPACITY	WIRE SIZE/GAUGE
P/N 9700-62695	LMG4501	5,000 lbs.	.18" - .60" (6AWG - 4/0AWG)
P/N 9700-80827	LMG4601	10,000 lbs.	.30" - .80" (1AWG - 450MCM)
P/N 9700-60000	LMG4801	12,000 lbs.	.70" - 1.25" (397MCM - 1130MCM)

LSB Hoist

- 360° rotating handle provides versatile rigging options when used in confined spaces
- Impact resistant stamped steel housing withstands years of rigorous use
- Low handle effort provided by double reduction gearing and short handle
- Free wheeling mechanism allows one-handed take up and positioning of slack chain
- Meets or exceeds minimum 4:1 design factor and all requirements of ASME/ANSI Standard B-30.21

PART NUMBER	MODEL	CAPACITY	HOOK TO HOOK (Min)	AVERAGE HANDLE EFFORT	HANDLE LENGTH	LIFT
P/N 9000-15010	LSB1500B-10	1,500 lbs.	11 5/8"	46 lbs.	9.25"	10'
P/N 9700-81033	LSB3000B-10	3,000 lbs.	13"	59 lbs.	14.56"	10'
P/N 9700-81038	LSB6000B-10	6,000 lbs.	14 9/16"	75 lbs.	14.56"	10'



G Model Chain Hoists

- Malleable iron housings, key internal components made of heat treated alloy steel, riveted construction
- Free chain feature allows easy positioning and set-up; also features reversible handle
- 360° swivel hooks are equipped with safety latches for positive load engagement
- Double pawl models can be operated with half strokes of lever for use in close quarters



PART NUMBER	MODEL	CAPACITY	LIFT	STRANDS OF LOAD CHAIN	MIN. DIST. BETWEEN HOOKS	AVERAGE HANDLE EFFORT	MINIMUM INCREMENT	PAWL
P/N 9007-00100	AG	1,500 lbs.	56.5"	1	13"	56 lbs.	.624/.313	Single
P/N 9007-00123	ATG	3,000 lbs.	57"	2	15"	60 lbs.	.313/.156	Single
P/N 9701-05473	ATGI	3,000 lbs.	57"	2	15"	60 lbs.	.313/.156	Double
P/N 9007-00130	FTG	6,000 lbs.	57"	2	17 5/8"	120 lbs.	.500/.250	Single
P/N 9007-00140	ZG-6	12,000 lbs.	53"	4	25"	124 lbs.	.250	Single

TB602 & TB603 Mini Hoists

- Performs just like the larger hoists, but small enough to fit in a hard hat
- Weston type load brake
- Forged upper and lower hooks with latches standard
- Plated load chain is standard
- Free wheeling feature serves to quickly attach the load
- Hardened link type steel load chain

TB-602 Models feature a 550 lb. capacity:

P/N 9000-60205	TB602-5	5' lift
P/N 9000-60201	TB602-10	10' lift

TB-602 Models feature a 1100 lb. capacity:

P/N 9701-09680	TB603-5	5' lift
P/N 9701-09683	TB603-10	10' lift



COFFING[®]
HOISTS

LITTLE MULE[®]

**Altec
Supply**

Coffing Hoists/Little Mule Products offer the widest variety of hoists and support gear for Industrial Duty, Material Lifting and Pulling Applications

CM Bandit Ratchet Lever Hoist



- Rugged, yet lightweight, design and construction allow for easy transport and use in even the most confining spaces
- CM SmartID is available standard on all CM Bandit ratchet lever hoists for the U.S. market - making it the world's first HMI-Certified ratchet lever hoist with RFID technology
- Easy free chaining feature allows for quick take up and positioning of slack chain. Designed not to accidentally free chain while under load
- 360 degree rotating handle allows for versatile rigging options when working in tight spaces
- Double reduction gearing provides easy operation with low handle effort

Bandit Ratchet Lever Hoists						
Altec	Model	Capacity	Lift	Lever Pull To Lift Rated Load	Headroom	Handle Length
9706-48980	BAN07505	3/4 Ton	5'	45 Lbs.	12-7/8"	9-5/8"
9706-48983	BAN07510	3/4 Ton	10'	45 Lbs.	12-7/8"	9-5/8"
9706-48985	BAN07515	3/4 Ton	15'	45 Lbs.	12-7/8"	9-5/8"
9706-48986	BAN07520	3/4 Ton	20'	45 Lbs.	12-7/8"	9-5/8"
9706-48988	BAN15005	1-1/2 Ton	5'	64 Lbs.	14-1/4"	10-1/4"
9706-48991	BAN15010	1-1/2 Ton	10'	64 Lbs.	14-1/4"	10-1/4"
9706-48994	BAN15015	1-1/2 Ton	15'	64 Lbs.	14-1/4"	10-1/4"
9706-48995	BAN15020	1-1/2 Ton	20'	64 Lbs.	14-1/4"	10-1/4"
9706-48997	BAN30005	3 Ton	5'	3 & 6 Ton Bandit Ratchet Lever Hoists will be available in the Summer of 2015. Please call 1-877 GO ALTEC (1-877-462-5832) for availability and specifications at that time.		
9706-48998	BAN30010	3 Ton	10'			
9706-48999	BAN30015	3 Ton	15'			
9706-49000	BAN30020	3 Ton	20'			
9706-49003	BAN60005	6 Ton	5'			
9706-49004	BAN60010	6 Ton	10'			
9706-49005	BAN60015	6 Ton	15'			
9706-49010	BAN60020	6 Ton	20'			

Cable Hoist

- 360° swivel hooks are equipped with safety latches for positive load engagement
- Double-interlocking pawl mechanism assures one pawl is engaged at all times
- Special cast aluminum and zinc alloy housings with preformed, galvanized, extra-flexible aircraft cable

PART NUMBER	SINGLE LINE			DOUBLE LINE		
	MODEL	CAPACITY	HOOK TO HOOK (Min.)	CAPACITY	LIFT	HOOK TO HOOK (Min.)
P/N 9700-80120	115SB	1,000 lbs.	23' 20"	-	-	-
P/N 9700-80122	115DB	1,000 lbs.	23' 20"	2,000 lbs.	11.5'	27"
P/N 9700-80124	434WNB	1,500 lbs.	22' 20"	3,000 lbs.	11'	27"

Meets or exceeds minimum 4:1 design factor and all requirements of ASME/ANSI Standard B-30.21



RA Model Dual Ratchet and Pawl Design Hoist

- 360° swivel hooks are equipped with safety latches for positive load engagement
- Double-interlocking pawl mechanism assures one pawl is always engaged with the ratchet during lifting or lowering operations
- Meets or exceeds minimum 4:1 design factor and all requirements of ASME/ANSI Standard B-30.21

PART NUMBER	MODEL	CAPACITY	HOOK TO HOOK (Min)	HANDLE PULL AT RATED LOAD	HANDLE LENGTH	LIFT
P/N 9700-72886	RA15	1,500 lbs.	12.5"	59 lbs.	20.5"	60"
P/N 9000-20800	RA20	2,000 lbs.	12.5"	79 lbs.	20.5"	60"
P/N 9700-80115	RA30	3,000 lbs.	13.75"	82 lbs.	20.5"	60"
P/N 9700-80118	RA40	4,000 lbs.	13.75"	110 lbs.	20.5"	60"

6,000 lb. Series Lineman's Strap Hoist

- P/N 9000-96159 features standard hooks with safety latches, P/N 9700-40528 features hot stick rings with safety latches on all hooks, control surfaces, and quick disconnect shaft, and P/N 9701-13269 features standard hooks with heavy duty swivel gate latches

PART NUMBER	MODEL	CAPACITY	LIFT	DOUBLE LINE			NET WEIGHT
				MINIMUM HEADROOM	WEB STRAP LENGTH	HANDLE LENGTH	
P/N 9000-96159	6000A	6,000 lbs.	5'	27"	12'	30"	26.5 lbs.
P/N 9700-40528	6000DA*	6,000 lbs.	5'	27"	12'	30"	26.5 lbs.
P/N 9701-13269	6000CA	6,000 lbs.	5'	29"	12'	30"	26.5 lbs.

Meets or exceeds minimum 4:1 design factor and all requirements of ASME/ANSI Standard B-30.21

COFFING® **LITTLE MULE®**
HOISTS

Coffing Hoists/Little Mule Products offer the widest variety of hoists and support gear for Industrial Duty, Material Lifting and Pulling Applications

Altec Supply

GRIPS, HOISTS, & RIGGING

USA: 1-877-GO ALTEC
(1-877-462-5832)

www.alteconnect.com

COFFING[®] HOISTS

by Columbus McKinnon



Model 250 Lineman's Strap Hoists

- P/N 9701-13132 features standard hooks with safety latches, P/N 9700-40525 features hot stick ring hooks with safety latches, P/N 9701-13135 features standard hooks with heavy duty swivel gate latches, and P/N 9701-13140 features hot stick ring hooks with hot stick ring safety latches
- Unsurpassed in load spotting due to a friction brake design and fine tooth pawl
- Safety gate latches have been added; designed with a 4:1 safety factor

SINGLE LINE **DOUBLE LINE**

PART NUMBER	MODEL	CAPACITY	LIFT	HOOK TO HOOK (Min.)	CAPACITY	LIFT	MINIMUM HEADROOM
P/N 9701-13132	250A	1,000 lbs.	9'	21"	2,000 lbs.	4.25'	25"
P/N 9700-40525	250DA	1,000 lbs.	9.25'	18"	2,000 lbs.	4.25'	25"
P/N 9701-13135	250CA	1,000 lbs.	9'	21"	2,000 lbs.	4.25'	25"
P/N 9701-13140	250DHA	1,000 lbs.	9.25'	18"	2,000 lbs.	4.25'	25"

Model 300 Lineman's Strap Hoists

- Features fiberglass handle, polyester webbing, and 360° swivel hooks equipped with safety latches
- Double-locking pawl mechanism assures one pawl is engaged at all times
- Stainless steel springs and shafts are corrosion resistant and the hoist itself is durable and portable
- Insulated fiberglass handle with overload protection and polyester webbing adds non-conductivity
- P/N 9700-40531 features standard hooks with safety latches, P/N 9007-00300 features hot stick ring hooks with safety latches, P/N 9700-91801 features standard hooks with heavy duty swivel gate latches, and P/N 9700-91804 features hot stick ring hooks with hot stick ring safety latches on all hooks, control surfaces, and quick disconnect shaft

PART NUMBER	SINGLE LINE				DOUBLE LINE			
	MODEL NUMBER	CAPACITY	LIFT	MINIMUM HEADROOM	CAPACITY	LIFT	MINIMUM HEADROOM	WEB STRAP LENGTH
P/N 9700-40531	300A	1500 lbs.	9'	21"	3000 lbs.	4.25'	25"	10'
P/N 9007-00300	300DA	1500 lbs.	9'	18"	3000 lbs.	4.25'	25"	10'
P/N 9700-91801	300CA	1500 lbs.	9'	21"	3000 lbs.	4.25'	25"	10'
P/N 9700-91804	300DHA*	1500 lbs.	9.25'	18"	3000 lbs.	4.25'	25"	10'

*Includes Hot Stick Rings on All Hooks, Control Surfaces, and Quick Disconnect Shaft

Model 322 Lineman's Strap Hoists

- Insulated fiberglass handle with overload protection and polyester webbing adds non-conductivity
- P/N 9700-21966 features standard hooks with safety latches, P/N 9700-72840 features hot stick ring hooks with safety latches on all hooks and control surfaces and quick disconnect shaft, P/N 9701-13152 features standard hooks with heavy duty swivel gate latches, and P/N 9700-91641 features hot stick ring hooks with hot stick ring safety latches on all hooks, control surfaces, and quick disconnect shaft

PART NUMBER	SINGLE LINE				DOUBLE LINE		
	MODEL	CAPACITY	LIFT	MINIMUM HEADROOM	CAPACITY	HOOK TO HOOK (MIN)	
P/N 9700-21966	322B	1,500 lbs.	14'	20"	3,000 lbs.	7'	23"
P/N 9700-72840	322DB*	1,500 lbs.	14'	20"	3,000 lbs.	7'	23"
P/N 9701-13152	322CB	1,500 lbs.	14'	23"	3,000 lbs.	7'	27"
P/N 9700-91641	322DHB*	1,500 lbs.	14'	22"	3,000 lbs.	7'	26"

Meets or exceeds minimum 4:1 design factor and all requirements of ASME/ANSI Standard B-30.21

Model 344 Lineman's Strap Hoists

- P/N 9700-21965 features standard hooks with safety latches, P/N 9701-07369 features hot stick ring hooks with safety latches on all hooks, control surfaces, and quick disconnect shafts, P/N 9701-13146 features standard hooks with heavy duty swivel gate latches, and P/N 9701-13149 features hot stick ring hooks with hot stick ring safety latches on all hooks and control surfaces and quick disconnect shaft

PART NUMBER	SINGLE LINE				DOUBLE LINE		
	MODEL	CAPACITY	LIFT	MINIMUM HEADROOM	CAPACITY	LIFT	HOOK TO HOOK (Min)
P/N 9700-21965	344B	2,000 lbs.	11'	20"	4,000 lbs.	5 1/2'	23"
P/N 9701-07369	344DB*	2,000 lbs.	11'	20"	4,000 lbs.	5 1/2'	23"
P/N 9701-13146	344CB	2,000 lbs.	11'	23"	4,000 lbs.	5 1/2'	27"
P/N 9701-13149	344DHB*	2,000 lbs.	11'	22"	4,000 lbs.	5 1/2'	26"

*Includes Hot Stick Rings on All Hooks, Control Surfaces, and Quick Disconnect Shaft

GRIPS, HOISTS, & RIGGING

USA: 1-877-GO ALTEC (1-877-462-5832)

www.alteconnect.com

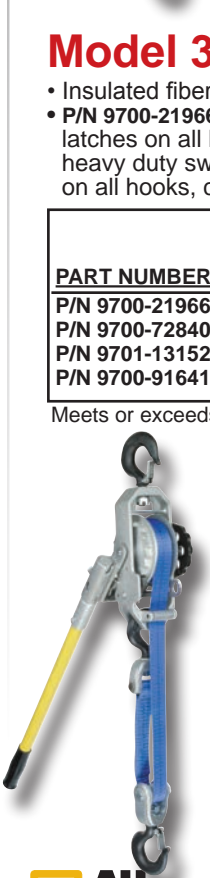

Coffing Hoists/Little Mule Products offer the widest variety of hoists and support gear for Industrial Duty, Material Lifting and Pulling Applications

HOISTS

GRIPS, HOISTS, & RIGGING

Mechanical Hoists



- Compact and portable, this hoist operates easily in close clearance work spaces
- Forged-steel load hooks at both ends swivel 360° for easy attachment and to help maintain axial alignment during use
- Two-way handle swings to either side and rounded stop at end helps keep hand on handle
- Standard lift is 5.5'
- Rounded stop at end helps keep hand on handle

Part Number	Chance	Handle Rating	Pull at Rating	Hook-to-Hook Minimum	Weight (lb.)
9000-90438	C3090438	3/4 ton	65 lb.	11"	14
9000-99410	3011S	1 ton	90 lb.	11"	14
9000-90439	C3090439	1 1/2 ton	60 lb.	16"	22
9000-04012	4012	2 ton	90 lb.	11"	28 1/2
9000-90440	C3090440	3 ton	60 lb.	19 3/4"	30 1/2
9000-90441	C3090441	4 1/2 ton	70 lb.	24 1/2"	47
9000-90442	C3090442	6 ton	70 lb.	24 1/2"	50

Chance Chain Hoist Repair Kit
P/N 9000-30903 C3090349

A.B. Chance Nylon Strap Hoists

- Designed with special features these hoists offer a choice of two handle options for utility maintenance and construction
- For rubber-glove work, select hoist with Plastisol cap on handle end
- For operation by hot line tools, specify hoist with swivel-eye on handle end
- Features hot stick rings on hooks and latches
- Single strap of 1-Ton units reach and lifts farther; 2-Ton units employ a sheave-mounted hook in a double-strap becket

P/N 9701-55355	PSC3090323	1 Ton Hoist, Regular Handle
P/N 9700-52052	PSC3090467	1 Ton Hoist, Hot Stick Handle
P/N 9700-53518	PSC3090468	2 Ton Hoist, Hot Stick Handle



Electrically Driven Capstain Hoists



P/N 415-10000

- Improved design features a multiple planetary drive/backstop clutch assembled on the center shaft of a steel gearcase with full-length internal teeth
- Handles more rugged jobs, extends service life and reduces maintenance
- Lightweight, powerful, and portable
- Moves many heavyweight tasks and can get into remote or difficult-access sites
- Designed for use with setting utility poles, pulling wheeled equipment over obstacles, raising transformers (even over fences in back lots), hoisting heavy insulators, stringing and tensioning conductors, pulling cable (indoors and underground)
- Operator effort remains low for typical loads simply by adding wraps on the capstan drum
- Control is so accurate, loads can be moved fractions of an inch
- Standard drum style
- P/N 415-10000 and P/N 7013-00035 feature load ratings of 1,000 lb.; P/N 7013-00040 features a load rating of 3,000 lb.

Altec P/N	Chance	Power Source	Rope Speed at Rated Load	Source (Min.)
P/N 415-10000	C3081172	12 V DC	22' per min.	90 Amps
P/N 7013-00035	C3081170	115 V AC	40' per min.	14 Amps
P/N 7013-00040	C3081370	115 V AC	2' per min.	14 Amps



P/N 7013-00035 &
P/N 7013-00040

USA: 1-877-GO ALTEC
(1-877-462-5832)

www.alteconnect.com

Please contact 1-877-GO ALTEC (1-877-462-5832) for additional information regarding Chance products.

HOISTS

Hydraulically Driven Capstain Hoists



P/N 9000-81180



P/N 9000-80900

- Improved design features a multiple planetary drive/backstop clutch assembled on the center shaft of a steel gearcase with full-length internal teeth
- Handles more rugged jobs, extends service life and reduces maintenance
- Lightweight, powerful, and portable
- Moves many heavyweight tasks and can get into remote or difficult-access sites
- Designed for use with setting utility poles, pulling wheeled equipment over obstacles, raising transformers (even over fences in back lots), hoisting heavy insulators, stringing and tensioning conductors, pulling cable (indoors and underground)
- Operator effort remains low for typical loads simply by adding wraps on the capstan drum
- Control is so accurate, loads can be moved fractions of an inch
- Standard drum style
- **P/N 9000-81180** features a load rating of 1,000 lb.
- **P/N 9000-80900** features a load rating of 3,000 lb.

Altec P/N	Chance	Rope Speed at Rated Load	Source (Gallons/Min.)
P/N 9000-81180	C3081180	93' per min.	8 gal.; 1,000 psi
P/N 9000-80900	C3080900	30' per min.	8 gal.; 1,000 psi

Capstan 1000 Lb. Gas Hoist

- Improved design features a multiple planetary drive/backstop-clutch assembled on the center shaft of a steel gearcase with full-length internal teeth
- This design handles more rugged jobs, extends service life and reduces maintenance
- Lightweight yet powerful, these portable hoists move many heavyweight tasks and can get into remote or difficult-access sites, for example: Setting utility poles, pulling wheeled equipment over obstacles, raising transformers (even over fences in back lots), hoisting heavy insulators, stringing and tensioning conductors, pulling cable (indoors and underground)
- Operator effort remains low for typical loads simply by adding wraps on the capstan drum
- Control is so accurate, loads can be moved fractions of an inch
- Rope speed at 1,000 lb. rated working load is 40' per minute
- Engine speed of 8,000 rpm

P/N 9007-30811 C3081190



Universal Bracket/Chain Clamp for Capstan 1000 Lb. Gas Hoist



P/N 9700-26860



P/N 9007-41703

- Recommended for use with Chance gasoline 1,000-lb. hoist (P/N 9007-30811)
- **P/N 9700-26860** also fits other 1,000-lb. Series 90 and earlier 750-lb. Chance hoists
- **P/N 9700-26860** bolts down or uses two P/N 9007-41703 chain clamps for mounting on poles, angles, or beams

P/N 9700-26860 C3080925 Universal Bracket

P/N 9007-41703 C4170346 Chain Clamp for Universal Bracket*

*2 chain clamps required for each P/N 9700-26860 bracket

Please contact 1-877-GO ALTEC (1-877-462-5832) for additional information regarding Chance products.

USA: 1-877-GO ALTEC (1-877-462-5832)

www.alteconnect.com

HOIST ACCESSORIES

GRIPS, HOISTS, & RIGGING

Capstan Brackets without Chain Clamps

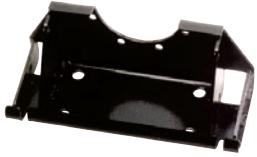

- Bolt-down bracket for 1,000 lb. hoists
- Does not include chain clamps
- 8.82 lb.

P/N 7013-00036 E3081321P



- Bolt-down bracket for 3,000 lb. hoists
- Does not include chain clamps
- 14 lb.

P/N 414-80003 E3081434P

Capstan Brackets with Chain Clamps

- All-purpose bracket Series 90 hoists
- Includes 2 chain clamps for poles, angles, or beams

P/N 9000-81335 C3081335 1,000 lb. rating
P/N 8040-00337 C3081443 3,000 lb. rating



“C” Bracket for Hoist Storage

- To store hoist on C-bracket, simply remove four bolts
- The C-bracket also can be bolted down for fixed-angle

P/N 415-11001 C3080890

Rope Lock Device Tool

- Includes two mounting bolts, washers, and a release lanyard
- Accepts 1/2", 5/8", and 3/4" rope

P/N 9000-80856 C3080856



Swivel Base Truck Mount



- Turntable design permits proper alignment without repositioning service vehicle
- Heavy-gauge steel base bolts directly to truck body wherever convenient
- Bracket can be pinned at every 15° interval around circular base for stringing, tensioning, adjusting sagging conductors, pulling in cable; hoisting equipment; setting poles; pulling vehicles

P/N 415-11000 C3080903

USA: 1-877-GO ALTEC
(1-877-462-5832)

www.alteconnect.com

Please contact 1-877-GO ALTEC (1-877-462-5832)
for additional information regarding Chance products.

HOIST ACCESSORIES

Hitch-Receiver Mount for Swivel-Base Mount

for 12V, 115V, 230V & Hydraulic 1,000-lb. Series 90 Capstan Hoists

Quick and convenient, fits 2"-square towing receivers

- Faster than any other method, job-ready mount puts capstan hoist in right position for pulling, stringing, and lifting jobs
- With hoist stored on it, mount's square tube simply inserts and pins in any 2"-square receiver of a Class III or IV towing hitch

Specially designed for swivel-base mount

- **P/N 9700-40980 T3080999** Hitch-receiver Mount features hole pattern specifically designed to fit Swivel-Base Mount **P/N 9701-23853 T3081506**
- Swivel mount's turntable design permits proper alignment without repositioning service vehicle
- Swivel mount permits pinning bracket at every 15-degree interval around circular base for: stringing, tensioning, and sagging conductors; pulling in cable; hoisting equipment; setting poles; and pulling vehicles

Utilize truck as portable power source

- Hitch-Receiver Mount is rated at 1,000 lb. to correspond with ratings of capstan hoists for which it is intended
- Only 12V, 115V and Hydraulic 1,000-lb.-rated hoists are recommended for truck mounting

P/N 9700-40980 T3080999 Hitch Mount for Capstan Hoist 21 lb./9.56 kg.

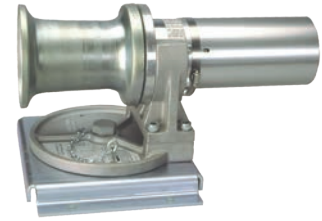

**PSC3081563
Hitch Mount Bracket
P/N 9700-40980
T3080999 with
Swivel Base
P/N 9701-23853
(T3081506)**

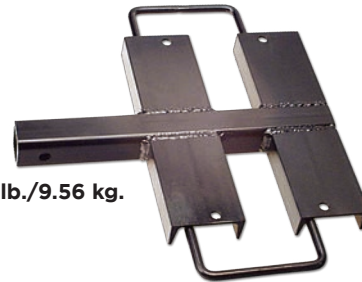
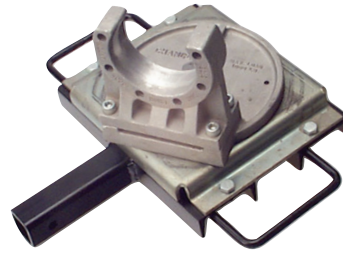

**1,000 lb. rating
Hitch-Receiver Mount
P/N 9700-40980
T3080999
as furnished**

Swivel Base Truck Mount

(Assembled Swivel Bracket and C-Bracket)

Sets at angles needed for variety of jobs

- Turntable design permits proper alignment without repositioning service vehicle
- Heavy-gauge steel base bolts directly to truck body wherever convenient
- Bracket can be pinned at 15-degree interval around circular base for: stringing, tensioning, and sagging conductors; pulling in cable; hoisting equipment; setting poles; and pulling vehicles

P/N 9701-23853 T3081506 23 lb. (10.35 kg.)



WARNING

This is not a personnel lifting device. A label on the unit warns against lifting people or loads directly above people.

Please contact 1-877-GO ALTEC (1-877-462-5832)
for additional information regarding Chance products.

Maasdam Long Haul Rope Pullers



- Uses highway-approved, 1/2" diameter wear resistant Dacron® polyester rope - twisted or braided
- Can accommodate an unlimited length of rope

PART NUMBER	MODEL	CAPACITY	MAXIMUM LIFT	LEVERAGE
P/N 9701-41778	A-0	1,500 lbs.	-	10:1
P/N 9701-41779	A-20	1,500 lbs.	20'	10:1
P/N 9701-41780	A-50	1,500 lbs.	50'	10:1
P/N 9701-41783	A-100	1,500 lbs.	100'	10:1

Maasdam POW'R-PULL® Strap Pullers



- Flexible and non-conductive strapping material conforms to and controls the load
- Precision-cast aluminum alloy ratchet wheel features one piece construction
- Interlocking, precision fit, steel alloy pawls with safety spacer and sleeve
- Cold-rolled, high strength, tempered steel frame and handle
- Drop-forged steel slip hooks with OSHA recommended safety latches
- "Notch-at-a-time" let-down



PART NUMBER	MODEL	CAPACITY	STRAP LENGTH	LEVERAGE
P/N 9701-41775	WS-1	2,000 lbs.	12'	10:1
P/N 9701-41776	WS-2	4,000 lbs.	6'	20:1
P/N 9701-41777	WS-25	2,000 lbs.	25'	10:1

PHOTOS:

P/N 9701-41775 Top Left
P/N 9701-41776 Bottom Left
P/N 9701-41777 Right

Harrington LB Lever Hoist



- Offers a low headroom, compact design that is perfect for use in tight quarters
- Rugged, all-steel construction actually weighs less than comparable aluminum models
- Weston style load brake incorporates 2 moisture resistant brake pads with four braking surfaces
- Patented spring-loaded freewheel mechanism permits easy adjustment of the load chain and safeguards against accidental freewheeling under load

PART NUMBER	MODEL	CAPACITY	LIFT	HEADROOM	AVERAGE PULL TO LIFT LOAD	LOAD CHAIN DIAMETER (mm)
P/N 9700-89414	LB008	1,500 lbs.	10'	11"	58 lbs.	5.6 x 1
P/N 9000-11215	LB015	3,000 lbs.	10'	13.8"	58 lbs.	7.1 x 1
P/N 9700-91548	LB030	6,000 lbs.	10'	16.5"	70 lbs.	10.0 x 1
P/N 9700-89415	LB060	12,000 lbs.	10'	22.4"	72 lbs.	10.0 x 2

Harrington LX Mini Puller

- Extremely compact and lightweight
- Design allows for fine adjustment of load tension
- Reliable heat treated carbon steel body
- Mechanical brake is completely enclosed
- Single step reduction gear assures load handling performance
- Low pulling force required for operation

P/N 9701-03275 LX003 40 lbs. Pull 1/4 Ton Capacity

P/N 9701-03291 LX005 62 lbs. Pull 1/2 Ton Capacity



A wide variety of hoists are available.

Please call 1-877-GO ALTEC for additional hoist options.

100% Made in the USA!



Lincoln Hoist®

The Original. Since 1949.

GRIPS, HOISTS, & RIGGING

Web Hoist Features:

- Models from 2000 lb. to 4000 lb. capacity.
- Hooks, grips and straps are color coded by capacity.
- Permanent ID plate with model number, serial number and capacity.
- Embedded RFID chip for improved asset tracking and inspection.
- Meets or exceeds ASME B30.21 specification for manual lever operated hoists.
- Double flanged drum - Keeps web strap from coming in contact with ratchet teeth.
- Breakable stress link - Alerts the operator to an overload condition. This Lincoln invention enables field replacement of an inexpensive link rather than a complete fiberglass handle.
- Open frame construction for easy inspection and cleaning.
- Four hook styles designed to meet application requirements and work practice standards.



Lineman's Web Hoist Model Specifications

ALTEC Part Number	Lincoln Hoist Model #	Handle Length inches	Single Line				Double line				Hoist Weight lbs.
			Capacity		Lift Dist. Feet	Hook to Hook Min. (In.)	Capacity		Lift Dist. Feet	Hook to Hook Min. (in.)	
			Lbs.	Tons			Lbs.	Tons			
P/N 9703-66360	2W10	30	1000	1/2	9	18	2000	1	4-1/2	23	10-1/4
P/N 9703-66361	2W10S	20	1000	1/2	9	18	2000	1	4-1/2	23	10-1/4
P/N 9703-47076	2W10B	30	1000	1/2	9	18	2000	1	4-1/2	23	10-1/4
P/N 9703-66362	2W10SB	20	1000	1/2	9	18	2000	1	4-1/2	23	10-1/4
P/N 9703-66363	2W10HB	30	1000	1/2	9	18	2000	1	4-1/2	23	10-1/4
P/N 9703-66364	2W10SHB	20	1000	1/2	9	18	2000	1	4-1/2	23	10-1/4
P/N 9703-66365	2W10U	30	1000	1/2	9	18	2000	1	4-1/2	23	10-1/4
P/N 9703-66366	2W10SU	20	1000	1/2	9	18	2000	1	4-1/2	23	10-1/4
P/N 9703-66367	3W08	30	1500	3/4	7	20	3000	1-1/2	3-1/2	24	10-1/4
P/N 9703-44625	3W08S	20	1500	3/4	7	20	3000	1-1/2	3-1/2	24	10-1/4
P/N 9703-66368	3W08B	30	1500	3/4	7	20	3000	1-1/2	3-1/2	24	10-1/4
P/N 9703-45705	3W08SB	20	1500	3/4	7	20	3000	1-1/2	3-1/2	24	10-1/4
P/N 9703-66369	3W08HB	30	1500	3/4	7	20	3000	1-1/2	3-1/2	24	10-1/4
P/N 9703-66370	3W08SHB	20	1500	3/4	7	20	3000	1-1/2	3-1/2	24	10-1/4
P/N 9703-66371	3W08U	30	1500	3/4	7	20	3000	1-1/2	3-1/2	24	10-1/4
P/N 9703-66372	3W08SU	20	1500	3/4	7	20	3000	1-1/2	3-1/2	24	10-1/4
P/N 9703-87524	3W15	30	1500	3/4	14	24	3000	1 1/2	6 1/4	31	
P/N 9703-89357	3W15B	30	1500	3/4	14	24	3000	1 1/2	6 1/4	31	
P/N 9703-89358	3W15U	30	1500	3/4	14	24	3000	1 1/2	6 1/4	31	
P/N 9703-89359	3W15HB	30	1500	3/4	14	24	3000	1 1/2	6 1/4	31	
P/N 9703-66373	4W12	36	2000	1	10	22	4000	2	5	30	14-3/4
P/N 9703-47075	4W12B	36	2000	1	10	22	4000	2	5	30	14-3/4
P/N 9703-66374	4W12HB	36	2000	1	10	22	4000	2	5	30	14-3/4
P/N 9703-66375	4W12U	36	2000	1	10	22	4000	2	5	30	14-3/4

USA: 1-877-GO ALTEC
(1-877-462-5832)

www.alteconnect.com

Hoist Options



"B" Option
This option adds hot stick rings to the hooks, pawl shafts and handle.



"HB" Option
This option adds hot stick rings to the hooks, latches, pawl shafts and handle.

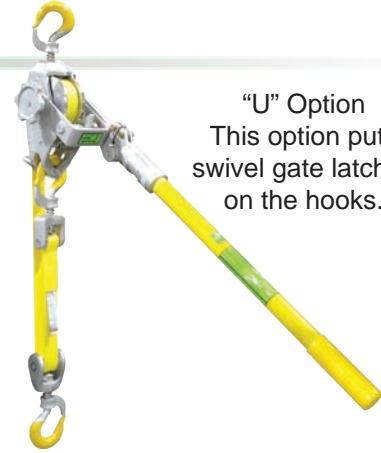

"U" Option
This option puts swivel gate latches on the hooks.

Model 30W08 Convertible Hoist

The 30W08 is designed to be quickly changed from single to double rigged. This way you don't have a block swinging freely on the strap or any extra parts to lose. These models are also available with all the options we offer on our other web strap hoists.



Lineman's Convertible Hoist Model Specifications

ALTEC Part Number	Lincoln Hoist Model #	Handle Length inches	Single Line				Double line				Hoist Weight lbs.
			Capacity		Lift Dist. Feet	Hook to Hook Min. (In.)	Capacity		Lift Dist. Feet	Hook to Hook Min. (in.)	
			Lbs.	Tons			Lbs.	Tons			
P/N 9703-66376	30W08	30	1500	3/4	7	23	3000	1-1/2	3-1/2	23	10
P/N 9703-66377	30W08S	20	1500	3/4	7	23	3000	1-1/2	3-1/2	23	10
P/N 9703-66378	30W08B	30	1500	3/4	7	23	3000	1-1/2	3-1/2	23	10
P/N 9703-66379	30W08SB	20	1500	3/4	7	23	3000	1-1/2	3-1/2	23	10
P/N 9703-66380	30W08HB	30	1500	3/4	7	23	3000	1-1/2	3-1/2	23	10
P/N 9703-66381	30W08SHB	20	1500	3/4	7	23	3000	1-1/2	3-1/2	23	10
P/N 9703-66382	30W08U	30	1500	3/4	7	23	3000	1-1/2	3-1/2	23	10
P/N 9703-66383	30W08SU	20	1500	3/4	7	23	3000	1-1/2	3-1/2	23	10

100% Made in the USA!



Lincoln Hoist[®]
The Original. Since 1949.

Please Call 1-877-GO ALTEC (1-877-462-5832) for Additional Information on Lincoln Hoist's Quality, 100% Made in the USA Hoists!

WEB STRAP PULLERS

Convertible Web Strap Pullers

All NEW Model

1 1/2 Ton
Small Frame
Convertible



Cast Bracket

1 1/2 Ton
Medium Frame
with Convertible Kit



Formed Bracket

2 Ton
Medium Frame
with Convertible Kit



With LUG-ALL's new convertible web strap pullers, all the parts needed to switch from a double line to single line are on the hoist, lessening the possibility of misplacing or losing parts.

Lighter Weight and More Headroom on Medium Frame Convertible Models

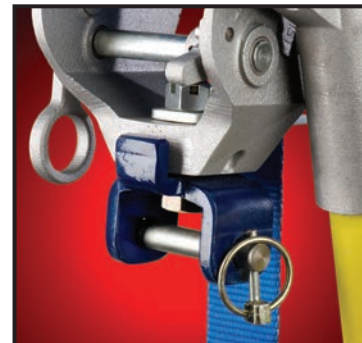

5 Hook Styles

- A - Standard Latching Hooks
- B - Hot Stick Rings and Latching Hooks
- U - Gate Type Hooks
- UB - Gate Type Hooks and Hot Stick Rings
- HB - Hot Stick Rings and Hook Latches

* All models equipped with quick release pulley block
* LUG-ALL grips, straps, and hooks are color-coded by capacity

ALTEC PART NUMBER	LUG-ALL MODEL	CAPACITY	SINGLE PULL DISTANCE		CAPACITY	DOUBLE PULL DISTANCE		STRAP LENGTH	HANDLE LENGTH	NET WEIGHT
			MIN	MAX		MIN	MAX			
P/N 9702-16488	2-CA	3/4 TON	20"	7'2"	1 1/2 TON	18"	3'6"	8'	30"	9.5
P/N 9702-16489	2-CB	3/4 TON	20"	7'2"	1 1/2 TON	18"	3'6"	8'	32"	9.75
P/N 9702-16490	2-CU	3/4 TON	22"	7'2"	1 1/2 TON	20"	3'5"	8'	30"	10
P/N 9702-16491	2-CUB	3/4 TON	22"	7'2"	1 1/2 TON	20"	3'5"	8'	32"	10.25
P/N 9702-16492	2-CHB	3/4 TON	22"	7'2"	1 1/2 TON	20"	3'5"	8'	32"	10.25
P/N 9702-16493	2-CA-1000	3/4 TON	20"	7'2"	1 1/2 TON	18"	3'6"	8'	20"	9.25
P/N 9702-16494	2-CB-1000	3/4 TON	20"	7'2"	1 1/2 TON	18"	3'6"	8'	22"	9.5
P/N 9702-16495	2-CU-1000	3/4 TON	22"	7'2"	1 1/2 TON	20"	3'5"	8'	20"	9.75
P/N 9702-16496	2-CUB-1000	3/4 TON	22"	7'2"	1 1/2 TON	20"	3'5"	8'	22"	10
P/N 9702-16497	2-CHB-1000	3/4 TON	22"	7'2"	1 1/2 TON	20"	3'5"	8'	22"	10
P/N 9702-16498	3-CA	3/4 TON	21"	11'1"	1 1/2 TON	21"	5'4"	11'5"	30"	13.25
P/N 9702-16499	3-CB	3/4 TON	21"	11'1"	1 1/2 TON	21"	5'4"	11'5"	32"	13.5
P/N 9702-16500	3-CU	3/4 TON	23"	11'1"	1 1/2 TON	23"	5'3"	11'5"	30"	13.75
P/N 9702-16501	3-CUB	3/4 TON	23"	11'1"	1 1/2 TON	23"	5'3"	11'5"	32"	14
P/N 9702-16502	3-CHB	3/4 TON	23"	11'1"	1 1/2 TON	23"	5'3"	11'5"	32"	14
P/N 9702-16503	4-CA	1 TON	21"	9'2"	2 TON	21"	4'5"	10'	36"	14.5
P/N 9702-16504	4-CB	1 TON	21"	9'2"	2 TON	21"	4'5"	10'	38"	14.75
P/N 9702-16505	4-CU	1 TON	23"	9'2"	2 TON	23"	4'4"	10'	36"	15
P/N 9702-16506	4-CUB	1 TON	23"	9'2"	2 TON	23"	4'4"	10'	38"	15
P/N 9702-16507	4-CHB	1 TON	23"	9'2"	2 TON	23"	4'4"	10'	38"	15

Specifications are subject to change without notice.

Meets ANSI B30.21

LUG-ALL®

WEB STRAP PULLERS

Standard Web Strap Pullers

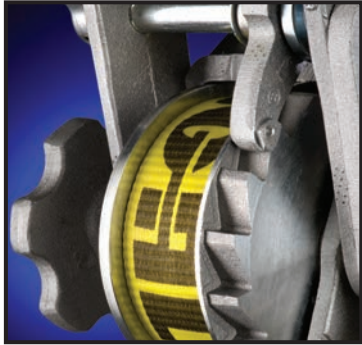

5 Hook Styles

- A - Standard Latching Hooks
- B - Hot Stick Rings and Latching Hooks
- U - Gate Type Hooks
- UB - Gate Type Hooks and Hot Stick Rings
- HB - Hot Stick Rings and Hook Latches

1 Ton
Small Frame



1 1/2 Ton
Small Frame



1 1/2 Ton
Medium Frame



2 Ton
Medium Frame



* All models equipped with quick release pulley block
 * LUG-ALL grips, straps, and hooks are color-coded by capacity

ALTEC PART NUMBER	LUG-ALL MODEL	CAPACITY	SINGLE PULL DISTANCE		CAPACITY	DOUBLE PULL DISTANCE		STRAP LENGTH	HANDLE LENGTH	NET WEIGHT
			MIN	MAX		MIN	MAX			
P/N 9701-09686	2-A	1/2 TON	16"	9'6"	1 TON	21"	4'5"	10'	30'	10.25
P/N 9701-09688	2-B	1/2 TON	16"	9'6"	1 TON	21"	4'5"	10'	32"	10.5
P/N 9701-00363	2-U	1/2 TON	18"	9'6"	1 TON	24"	4'4"	10'	30"	10.75
P/N 9701-09689	2-UB	1/2 TON	18"	9'6"	1 TON	24"	4'4"	10'	32"	11
P/N 9701-09691	2-HB	1/2 TON	18"	9'6"	1 TON	24"	4'4"	10'	32"	11
P/N 9700-99327	25-A	3/4 TON	16"	7'6"	1 1/2 TON	21"	3'5"	8'	20"	10
P/N 9701-09693	25-B	3/4 TON	16"	7'6"	1 1/2 TON	21"	3'5"	8'	22"	10.5
P/N 9701-09695	25-U	3/4 TON	18"	7'6"	1 1/2 TON	24"	3'4"	8'	20"	10.5
P/N 9701-09697	25-UB	3/4 TON	18"	7'6"	1 1/2 TON	24"	3'4"	8'	22"	10.75
P/N 9701-09699	25-HB	3/4 TON	18"	7'6"	1 1/2 TON	24"	3'4"	8'	22"	11
P/N 9701-09701	3-A	3/4 TON	19"	11'3"	1 1/2 TON	27"	5'1"	11'5"	30"	14
P/N 9701-09704	3-B	3/4 TON	19"	11'3"	1 1/2 TON	27"	5'1"	11'5"	32"	14.5
P/N 9701-09705	3-U	3/4 TON	21"	11'3"	1 1/2 TON	30"	5'0"	11'5"	30"	15
P/N 9701-09712	3-UB	3/4 TON	21"	11'3"	1 1/2 TON	30"	5'0"	11'5"	32"	15
P/N 9701-09713	3-HB	3/4 TON	20"	11'3"	1 1/2 TON	29"	5'0"	11'5"	32"	15.25
P/N 9701-09724	4-A	1 TON	19"	9'4"	2 TON	27"	4'1"	10'	36"	15.5
P/N 9701-09726	4-B	1 TON	19"	9'4"	2 TON	27"	4'1"	10'	38"	16
P/N 9701-00364	4-U	1 TON	21"	9'4"	2 TON	31"	4'0"	10'	36"	16
P/N 9701-09728	4-UB	1 TON	21"	9'4"	2 TON	31"	4'0"	10'	38"	16.5
P/N 9701-09730	4-HB	1 TON	20"	9'4"	2 TON	29"	4'0"	10'	38"	16.25

Specifications are subject to change without notice.

Please contact your Altec Supply Account Manager for more information regarding quality Lug-All Products.

GRIPS, HOISTS, & RIGGING

USA: 1-877-GO ALTEC
(1-877-462-5832)

www.alteconnect.com

HOOK A Huskie Tool Company

Manufacturers of Lifting & Pulling Equipment

DESIGNED FOR SAFETY

DURABLE • VERSATILE • HIGH QUALITY

Hook International manufactures the finest portable, Cable, Strap & Chain Hoists meeting and exceeding ANSI standards. These durable, high quality hoists are engineered for safe and easy operation suited for a variety of applications making it the top choice among utility companies and industrial distributors.

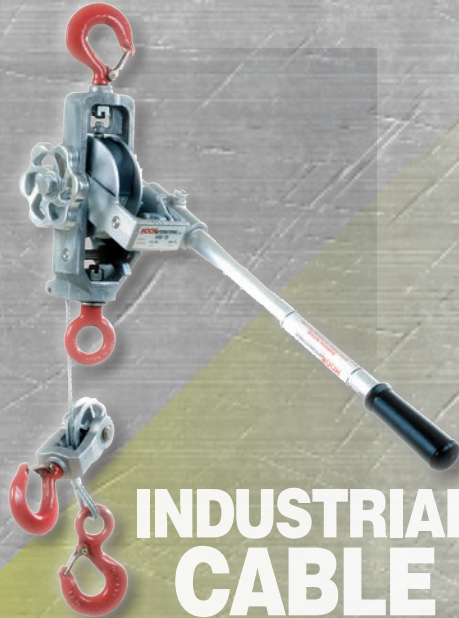

INDUSTRIAL CABLE HOISTS

INDUSTRIAL CABLE HOIST

- Durable, high quality hoists are engineered for safe and easy operation
- All rotating shafts are mounted on bronze bushing to reduce wear
- Hard coated anodized aluminum cable guide provides extra abrasive resistance
- Double interlocking pawl system assures precise load adjustments
- Aluminum winding wheel for slack cable take up is standard on all models
- Superior 360° drop forged swiveling hooks are equipped with safety latches
- Meets ASME/ANSI Standard B-30.21

PART NUMBER	MODEL	SINGLE LINE CAPACITY	LIFT FT.	DOUBLE LINE CAPACITY	LIFT FT.	CABLE DIA. IN.
P/N 9702-08484	H1-15	1,000 lbs.	15	-	-	7/32
P/N 9702-08517	H12-15	1,000 lbs.	15	2,000 lbs.	7.5	7/32
P/N 9702-08525	H153-13	1,500 lbs.	13	3,000 lbs.	6.5	7/32
P/N 9702-08539	H15-20	1,500 lbs.	20	-	-	7/32
P/N 9702-08544	H153-20	1,500 lbs.	20	3,000 lbs.	10	7/32
P/N 9702-08546	H153-30	1,500 lbs.	30	3,000 lbs.	15	7/32
P/N 9702-08548	H24-20	2,000 lbs.	20	4,000 lbs.	10	1/4
P/N 9702-08561	H24-12HD	2,000 lbs.	12.5	4,000 lbs.	6.25	9/32
P/N 9702-08565	H2.5-6			5,000 lbs.	6	9/32

LINEMAN'S RATCHET LEVER HOIST

P/N 9701-79315	FR500	1/4 Ton - 3' Lift
P/N 9702-07898	FR1000	1/2 Ton - 5' Lift
P/N 9702-07899	FR1505	3/4 Ton - 5' Lift
P/N 9702-07900	FR1510	3/4 Ton - 10' Lift
P/N 9702-07901	FR1515	3/4 Ton - 15' Lift
P/N 9702-07902	FR1520	3/4 Ton - 20' Lift
P/N 9702-07903	FR2005	1 Ton - 5' Lift
P/N 9702-07904	FR2010	1 Ton - 10' Lift
P/N 9702-07905	FR2015	1 Ton - 15' Lift
P/N 9702-07906	FR2020	1 Ton - 20' Lift
P/N 9702-07907	FR3005	1 1/2 Ton - 5' Lift

P/N 9702-07908	FR3010	1 1/2 Ton - 10' Lift
P/N 9702-07910	FR3015	1 1/2 Ton - 15' Lift
P/N 9702-07911	FR3020	1 1/2 Ton - 20' Lift
P/N 9702-07912	FR6005	3 Ton - 5' Lift
P/N 9702-07913	FR6010	3 Ton - 10' Lift
P/N 9702-07914	FR6015	3 Ton - 15' Lift
P/N 9702-07915	FR6020	3 Ton - 20' Lift
P/N 9702-07916	FR12005	6 Ton - 5' Lift
P/N 9702-07917	FR12010	6 Ton - 10' Lift
P/N 9702-07919	FR12015	6 Ton - 15' Lift
P/N 9702-07920	FR12020	6 Ton - 20' Lift

All Hook Ratchet Hoists use a Grade 100 Chain and are ANSI certified.



RATCHET LEVER HOISTS





**WHEN YOU NEED A TOUGH, DURABLE
HOIST THAT ENSURES THE BEST
FEATURES AND EASE OF OPERATION:**

HOOK A Huskie Tool Company

Manufacturers of Lifting & Pulling Equipment

LINEMAN'S STRAP HOIST

- Durable, lightweight hoists are engineered for safe and easy operation
- Heavy duty 360° drop forged swiveling hooks are equipped with safety latches
- P/N 9701-58422, P/N 9701-58429, and P/N 9701-58433 are standard strap hoists
- P/N 9701-58426 and P/N 9701-58430 feature hot stick ring hooks with safety latches
- P/N 9701-58428 and P/N 9701-58431 feature hot stick ring hooks with hot stick safety latches

PART NUMBER	MODEL	SINGLE LINE		DOUBLE LINE	
		CAPACITY	LIFT FT.	CAPACITY	LIFT FT.
P/N 9701-58422	E153-10	1,500 lbs.	10	3,000 lbs.	5
P/N 9701-58426	EH153-10	1,500 lbs.	10	3,000 lbs.	5
P/N 9701-58428	EHHS153-10	1,500 lbs.	10	3,000 lbs.	5
P/N 9701-58429	E24-12	2,000 lbs.	10	4,000 lbs.	7.5
P/N 9701-58430	EH24-12	2,000 lbs.	10	4,000 lbs.	7.5
P/N 9701-58431	EHHS24-12	2,000 lbs.	10	4,000 lbs.	7.5
P/N 9701-58433	E2.5-6	5,000 lbs.	6		
P/N 9705-88787	E12-10-30	1,000 lbs.	10	2,000 lbs.	5
P/N 9705-88788	E12-10	1,000 lbs.	10	2,000 lbs.	5
P/N 9705-88789	EH12-10-30	1,000 lbs.	10	2,000 lbs.	5
P/N 9705-88790	EH12-10	1,000 lbs.	10	2,000 lbs.	5
P/N 9705-88791	EHG12-10-30	1,000 lbs.	10	2,000 lbs.	5
P/N 9705-88792	EH12-10	1,000 lbs.	10	2,000 lbs.	5
P/N 9705-88793	EHHS12-10-30	1,000 lbs.	10	2,000 lbs.	5
P/N 9705-88794	EHHS12-10	1,000 lbs.	10	2,000 lbs.	5
P/N 9705-88795	EHG153-10	1,500 lbs.	10	3,000 lbs.	5
P/N 9705-88796	EHS153-10-30	1,500 lbs.	10	3,000 lbs.	5
P/N 9705-88797	EHHS153-10-30	1,500 lbs.	10	3,000 lbs.	5
P/N 9705-88799	EHG24-12	2,000 lbs.	12	4,000 lbs.	5

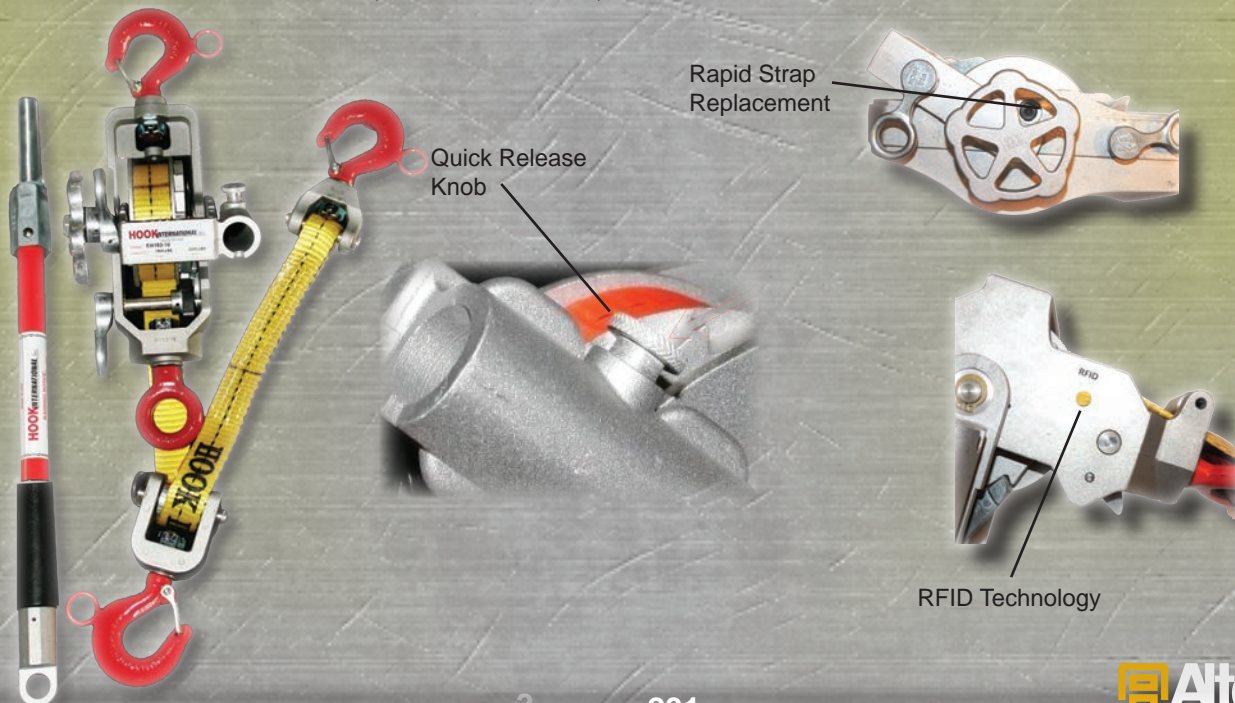

GRIPS, HOISTS, & RIGGING

USA: 1-877-GO ALTEC
(1-877-462-5832)

www.alteconnect.com

HOIST CONVERSION

Please note that the following comparisons are the closest available.

There are differences in specifications and dimensions between the builders, and one tool will not be an exact match for another. Please confirm the specifications to be sure that the tool is correct for the intended job.

CABLE HOISTS				
LINCOLN HOIST	LUG-ALL	LITTLE MULE	HOOK INTERNATIONAL	A.B. CHANCE
LH 1000-15	9702-14986 1000-15	115SA	9702-08484 H1-15	
LH 1500-25	1500-25		9702-08539 H15-20	
LH 2250-15	2250-15	115DA	9702-08525 H153-13	
LH 2250-20	2250-20		9702-08517 H12-15	
LH 2250-38	2250-38		-	
LH 3000-10	9704-70172 3000-10	202WNA	9702-08544 H153-20	
LH 3000-30	3000-30	434WNA	9702-08546 H153-30	
LH 4000-20	4000-20		9702-08548 H24-20	
WEB STRAP HOISTS				
LINCOLN HOIST	LUG-ALL	LITTLE MULE	HOOK INTERNATIONAL	A.B. CHANCE
9703-66360 2W10	9701-09686 2A		9705-88787 E12-10-30	
9703-66361 2W10S		9701-13132 250A	9705-88788 E12-10	
9703-47076 2W10B	9701-09688 2B		9705-88789 EH12-10-30	
9703-66362 2W10SB		9700-40525 250DA	9705-88790 EH12-10	
9703-66365 2W10U	9701-00363 2U		9705-88791 EHG12-10-30	
9703-66366 2W10SU		9701-13135 250CA	9705-88792 EHG12-10	
9703-66363 2W10HB	9701-09691 2HB		9705-88793 EHHS12-10-30	
9703-66364 2W10SHB		9701-13140 250DHA	9705-88794 EHHS12-10	
9703-44625 3W08S	9700-99327 2010920111 / 25A	9700-40531 300A	9701-58422 E153-10	
9703-45705 3W08SB	9701-09693 2010920109 / 25B	9007-00300 300DA	9701-58426 EH153-10	
9703-66372 3W08SU	9701-09695 2010930118 / 25U	9700-91801 300CA	9705-88795 EHG153-10	
9703-66370 3W08SHB	9701-09699 2010930137 / 25HB	9700-91804 300DHA	9701-58428 EHHS153-10	
9703-66376 30W08	30		9701-58426 EH153-10	9702-47165 PSC3090451
9703-66378 30W08B	30B		9701-58426 EH153-10	
9703-66382 30W08U	30U		9705-88796 EHG153-10-30	
9703-66380 30W08HB	30HB		9705-88797 EHHS153-10-30	9700-90448 PSC3090452
9703-66373 4W12	9701-09724 4A	9700-21965 344B	9701-58429 E24-12	
9703-47075 4W12B	9701-09726 4B	9701-07369 344DB	9701-58430 EH24-12	
9703-66375 4W12U	9701-00364 4U	9701-13146 344CB	9705-88799 EHG24-12	
9703-66374 4W12HB	9701-09730 4HB	9701-13149 344DHB	9701-58431 EHHS24-12	



Handline Equipment

GRIPS, HOISTS, & RIGGING

**USA: 1-877-GO ALTEC
(1-877-462-5832)**

www.alteconnect.com

Complete Hand Line Sets with 1/2" Polypropylene Rope



- Complete handline sets available with rope lengths of 60', 80', and 100'
- Features selected length of 1/2" polypropylene rope, (1) P/N 9000-99824 handline block, (1) P/N 7054-00515 handline hook, and (1) swivel snap hook

P/N 9701-14289 3555 60' overall length
P/N 9000-03556 3556 80' overall length
P/N 9700-23393 3557 100' overall length

Other lengths and styles of rope are available upon request. Please call 1-877-GO ALTEC (1-877-462-5832) for additional information.

Complete Hand Line Sets with 1/2" Soft Navy Braid Rope



- Complete handline sets available with rope lengths of 60' and 80'
- Features selected length of 1/2" soft navy braid rope, (1) P/N 9000-99824 handline block, (1) P/N 7054-00515 handline hook, and (1) swivel snap hook

P/N 9701-97802 CTO1732 60' overall length
P/N 9701-97804 CTO1733 80' overall length
P/N 9701-97805 CTO1789 100' overall length

Other lengths and styles of rope are available upon request. Please call 1-877-GO ALTEC (1-877-462-5832) for additional information.



Hand Line Block

- Block and sheave constructed of rugged nylon fiberglass reinforced high di-electric material
- Side opening block with swivel hook and safety snap
- 4" block size
- Rated with a 3-1 safety factor

P/N 9000-99824 Hastings 3550



Hand Line Block

- Block and sheave constructed of rugged nylon fiberglass reinforced high di-electric material
- Closed block with swivel hook and safety snap
- 4" block size
- Rated with a 3-1 safety factor

P/N 9000-03551 Hastings 3551

Hand Line Hook



- Constructed from manganese bronze alloy
- Use with up to 1/2" diameter rope
- 600 lb. working capacity

P/N 7054-00515 P10060



Hand Line Snap

- Drop-forged snap opening of 5/8"
- Rated capacity of 5,000 lbs.

P/N 9700-82779 P30142

Insulated Tackle Blocks



- Designed for all types of hoisting-related jobs
- Especially ideal for hot-line use
- Bodies are made from high-impac, dielectric thermoplastic material
- All hooks have full swivel capabilities
- Sheaves are made with fiberglass reinforced nylon material
- Shafts are stainless steel
- Swivel hooks are plated and include hot eye for application with hot sticks
- Maximum loading of blocks should not exceed 2,000 lbs.

Part Number	Hastings	Description	Upper	Lower
P/N 9702-06491	11361	Blocks only - no rope	2 Sheave	2 Sheave
P/N 9702-08088	11362	Blocks with 120' 1/2" Polydacron Rope	2 Sheave	2 Sheave
P/N 9701-29486	11367	Blocks only - no rope	3 Sheave	2 Sheave
P/N 9701-60072	11368	Blocks with 150' 1/2" Polydacron Rope	3 Sheave	2 Sheave
P/N 9702-08091	11052	Single Block Only	2 Sheave	
P/N 9702-08092	11051	Single Block Only	3 Sheave	

KLEIN TOOLS®



Committed to manufacture the highest quality hand tools with unmatched durability and comfort for over 155 years

Handline Equipment

Klein Swivel Anchor Hook



- Swivel prevents twisting and kinking of rope
- Swivel Hook is NOT an occupational protective hook

- Maximum safe load is 750 lbs.
- The swivel clevis on this drop-forged hook will engage with snap on block and tackle
- This is NOT an occupational protective hook, and is not for human support

P/N 9000-00259 259

Klein Swivel Hook Plunger Latch



- Drop-forged steel with swivel clevis and quick-acting plunger-style latch
- Designed to take 1/2" or lighter hand lines

- Swivel action prevents accidental fouling into secondary wires
- Throat opening is 5/8"
- Maximum safe load is 750 lbs.
- This is NOT an occupational protective hook, and is not for human support

P/N 9000-00470 470

Klein Anchor Hook



- This drop-forged hook is designed to slip under insulator and engage pin of cross-arm
- Throat opening is 3 1/4"
- Maximum safe load is 750 lbs.
- This is NOT an occupational

protective hook, and is not for human support

P/N 9000-00258 258

Klein Howe Wire Tool



- Strap is made of tough nylon webbing
- Swivel hook is forged steel with large opening
- Shank of hook lengthened to reach under insulator
- Other end has device to hold the load at any distance
- All metal parts are galvanized
- Maximum safe load is 500 lbs.

P/N 9000-17022 1702-20N

Klein Snap Hook



- General purpose drop-forged snap hook with eye at 90° to opening
- Throat opening is 1/2"

- Maximum safe load is 1,500 lbs.
- This is NOT an occupational protective hook, and is not for human support

P/N 9000-00443 443A

CAUTION: These hooks are NOT intended for use with occupational protective equipment.

Klein Blocks



P/N 9000-00267



P/N 9000-00268



P/N 9000-00269

- Blocks without ropes and hooks
- Made of light galvanized steel and aluminum alloy
- Sheaves have bronze bushings
- P/N 9000-00268 is a block with an eye to splice line to block and rope tie-off
- P/N 9000-00268 and P/N 9000-00269 feature an eye to splice line to block and rope tie-off hook
- Available with standard or guarded snap hooks
- Maximum safe load is 750 lbs.

P/N 9000-00267	267	Plain block
P/N 9000-00268	268	Standard Snap Hook
P/N 9000-00269	H268	Guarded Snap Hook

Klein Block and Tackle



- Maximum safe load is 750 lbs.
- P/N 9701-03293 is furnished with 25' of 3/8" rope, (1) P/N 9000-00267 block with a snap hook and (1) detachable forged anchor hook (P/N 9000-00258) on one end, and (1) block (P/N 9000-00268) with eye and rope tie-off hook on the other end
- P/N 9000-18023 has the same features as P/N 9701-03293, but with rope spliced to the P/N 9000-00268 block
- P/N 9007-18023 has the same features as P/N 9701-03293, except supplied with a detachable swivel anchor hook P/N 9000-00259 instead of hook P/N 9000-00258
- P/N 9701-00586 has the same features as P/N 9007-18023, but with the rope spliced to the P/N 9000-00268 block
- P/N 9702-02864 features 25' of 3/8" rope, (1) P/N 9000-00267 block with guarded snap hook, (1) detachable forged anchor hook (P/N 9000-00258) on one end, (1) block (P/N 9000-00268) with eye and rope tie-off hook on the other end
- P/N 9000-18024 has the same features as P/N 9702-02864, but with the rope spliced to the P/N 9000-00268 block

P/N 9701-03293	1802-30	
P/N 9000-18023	1802-30 S/R	
P/N 9007-18023	1802-30S	
P/N 9701-00586	1802-30S S/R	
P/N 9702-02864	H1802-30	
P/N 9701-15325	H1802-30S	
P/N 9000-18024	H1802-30 S/R	Guarded Snap Hook

HANDLINE EQUIPMENT

Slack Block Set with Swivel & 25' Twisted Rope



- 3/8" polypropylene twisted rope
- Also includes slack block with catch and swivel anchor hook
- 750 lbs. maximum safety capacity

P/N 9700-90219

Slack Block Set with Swivel & 25' Braided Rope



- 3/8" polyester/polypropylene blend rope
- Also includes slack block with catch and swivel anchor hook
- 750 lbs. maximum safety capacity

P/N 9700-90221

Complete Handline Sets



- Complete handline sets available with rope lengths of 60', 80', 100', and 120'
- Includes fiberglass reinforced nylon handline block, handline hook, and swivel snap hook
- Call 1-877-GO ALTEC to order custom lengths

P/N 9700-90222 60' long
 P/N 9700-90223 80' long
 P/N 9700-90224 100' long
 P/N 9700-97816 120' long

Handline Hook



- 500 lb. working load
- For use with up to 5/8" diameter rope
- Constructed from brass
- 1/2" and 3/4" diameter openings to accommodate rope

P/N 9700-90225

Handline Swivel Snap Hook



- 750 lb. working load
- Swivel hook with plunger latch
- Forged steel construction
- For use with up to a 1/2" diameter rope

P/N 9700-90227

Chance Flat Hook & Swivel Hook



- Rated for 750 lb. working load
- Not intended for human support
- Galvanized steel hook

P/N 9702-16792 PSC4032935 Flat Hook

RUEGG ROLLERS



Ruegg Slap-On #2 Overlash Cable Roller

- 1" Plastic Roller
- Spring steel latch keeps cable in roller
- Steel frame yellow chromate plating

P/N 9701-62914 SLAP-ON #2 PLAIN

Ruegg Slap-On #1

- 3" wide rubber roller
- Exclusive slide stop design (holds roller in place when pulling cable)
- Steel frame and yellow chromate plated

P/N 9701-62915 MODEL 100-1



Ruegg Pole Rollers

- 3" wide rubber roller
- Bolts onto strand clamp on pole
- Steel frame yellow chromate plating

P/N 9701-62916 POLE ROLLER



PULLING GRIPS

GRIPS, HOISTS, & RIGGING

Kellems Multiple Strength Type Pulling Grips



- Designed for pulling ACSR, Aluminum, or Copper bare conductor, ground wires, messenger strands, wire rope, and insulated cables
- High-strength galvanized steel strand, featuring double-weave mesh for greater strength and added mesh contact for longer or heavier pulling jobs
- Endless weave grip end lies flat on the cable and will not snag
- Ideal for overhead transmission and distribution line stringing where moderate loading is anticipated

Part Number	Hubbell	Range	Color Code	Eye Length	Mesh Length	Approximate Breaking Strength
P/N 9007-02044	03302044	.25"- .49"	Dark Green	9"	26"	6,800 lb.
P/N 9007-02046	03302046	.50"- .74"	Brown	9"	32"	10,000 lb.
P/N 9007-02048	03302048	.75"- .99"	Light Blue	11"	41"	14,400 lb.
P/N 9007-02050	03302050	1.00"-1.24"	Gold	12"	52"	24,600 lb.
P/N 9007-02052	03302052	1.25"-1.49"	Black	12"	56"	30,600 lb.
P/N 9701-11987	03302054	1.50"-1.74"	Red	12"	60"	30,600 lb.

Kellems DUA-Pull Type Pulling Grips



- DUA-Pull line accommodates ACSR, ACAR, and all aluminum and copper conductors
- The highest strength pulling grips manufactured for overhead transmission line stringing
- They may work both bare and insulated conductors, as well as synthetic rope
- Kellems's patented two-over, two-under weave design gives exceptional strength and gripping ability by putting more steel mesh in contact with the cable or rope surfaces
- Primarily used in overhead transmission line construction where loads and safety considerations require an extra high strength grip, and will mate with swivels and link-type connectors
- Also accommodates ground wires, messenger strands, wire ropes, and synthetic ropes
- Most commonly used for attaching pulling lines to conductors, conductors to running boards, and double socking" for conductor-to-conductor connections

Part Number	Hubbell	Range	Color Code	Eye Length	Mesh Length	Approximate Breaking Strength
P/N 9701-11992	033271037	.19"- .37"	Black	10"	24"	6,500 lb.
P/N 9701-01969	033271038	.38"- .62"	Dark Green	12"	36"	14,000 lb.
P/N 9701-01104	033271039	.63"- .87"	Red	13"	48"	20,000 lb.
P/N 9701-11995	033271040	.88"-1.12"	Blue	15"	60"	30,600 lb.

Kellems Pulling Grips



- High-strength galvanized steel strand, featuring double-weave mesh for greater strength and added mesh contact for longer or heavier pulling jobs
- Forged steel rotating eye mates with a swivel or shackle

Part Number	Hubbell	TYPE	RANGE	LENGTH
P/N 9007-41085	33041085	T-type	1.00" - 1.49"	33" overall (Top Photo)
P/N 9007-01027	03301027	Standard K-type	2.00" - 2.49"	45" overall (Bottom Photo)

Punch-Lok® Bands for Kellems Pulling Grips



- Punch-Lok® Bands are applied over the tail of a grip to prevent the mesh from being tripped or pulled loose
- They assure full gripping action by locking the mesh of the tail in tight contact with the cable or rope
- When the tail of a grip is the leading end, the bands are particularly important to prevent accidental release caused by tripping on obstructions

Part Number	Hubbell	Grip Banding Range	Band Width	Band Inside Diameter
P/N 9703-54599	20320050	1/4" - 1 1/8"	3/8"	1 3/8"
P/N 9703-54601	20320051	1 1/8" - 1 5/8"	3/8"	2"
P/N 9703-54602	20320052	1 5/8" - 2 1/4"	5/8"	2 1/2"
P/N 9703-54603	20320053	1 1/4" - 3-1/2"	5/8"	4"
P/N 9703-54604	20320054	3 1/2" - 5"	5/8"	6"

Please contact 1-877-GO ALTEC (1-877-462-5832) for additional information regarding Chance products.

USA: 1-877-GO ALTEC
(1-877-462-5832)

www.alteconnect.com

Pulling Grips Heavy Duty Rotating Eye

- Rotating eye can reduce rotational torque whenever pulling load is reduced
- Galvanized Steel mesh offers superior strength
- Forged Steel rotating eye will not bind when used with sheaves and blocks
- Shoulder protectors center the grip within a raceway and provide abrasion resistance
- Wide application for underground cables, communication and service lines
- Available as tool kit with all sizes below
- Mesh Material: Galvanized Steel mesh; Weave Type: Full double weave mesh; Mesh Type: Closed mesh



Altec	Woodhead	Order No.	Cable Diameter	Mesh Length	Eye Diameter	Approximate Break Strength
9705-88888	35865	130095-0124	12.70–15.49mm (.50–.61")	0.406m (16.00")	22.225mm (.875")	5,600 lb.
9705-88889	35866	130095-0125	15.88–19.05mm (.63–.75")	0.406m (16.00")	22.225mm (.875")	6,800 lb.
9705-88890	35880	130095-0135	19.05–25.15mm (.75–.99")	0.813m (32.00")	25.400mm (1.000")	9,600 lb.
9705-88891	35881	130095-0136	25.40–37.85mm (1.00–1.49")	0.838m (33.00")	34.925mm (1.375")	16,400 lb.
9705-88892	35882	130095-0137	38.10–50.55mm (1.50–1.99")	0.864m (34.00")	34.925mm (1.375")	16,400 lb.
9705-88893	35883	130095-0138	50.80–63.25mm (2.00–2.49")	0.914m (36.00")	41.275mm (1.625")	27,200 lb.
9705-88894	35884	130095-0139	63.50–75.95mm (2.50–2.99")	0.965m (38.00")	47.625mm (1.875")	33,000 lb.
9705-88895	35885	130095-0140	76.20–88.65mm (3.00–3.49")	0.991m (39.00")	47.625mm (1.875")	41,000 lb.
9705-88896	35886	130095-0141	88.90–101.35mm (3.50–3.99")	1.041m (41.00")	47.625mm (1.875")	48,000 lb.
9705-88897	35887	130095-0142	101.60–114.05mm (4.00–4.49")	1.067m (42.00")	47.625mm (1.875")	48,000 lb.
9705-88898	38897	130095-0143	114.30–126.75mm (4.50–4.99")	1.473m (58.00")	47.625mm (1.875")	48,000 lb.
9705-88899	35898	130095-0144	127.00–152.15mm (5.00–5.99")	1.524m (60.00")	47.625mm (1.875")	48,000 lb.
9705-88900	35899	130095-0145	152.40–177.55mm (6.00–6.99")	1.676m (66.00")	47.625mm (1.875")	48,000 lb.

Pulling Grips High Strength Flexible Eye

- Flexible eye works in both generous and tight spaces
- Galvanized, thick wire Steel mesh—highest strength pulling grip
- Shoulder protectors center the grip within a raceway and provide abrasion resistance
- Color-coded for easy identification
- Wide application for bare or insulated conductors, wire or synthetic rope



Altec	Woodhead	Order No.	Cable Diameter	Mesh Length	Eye Cable Thickness	Color	Approximate Break Strength
9705-88901	36610	130095-0272	4.83–9.40mm (.19–.37")	0.61m (24.00")	5.563mm (.219")	Black	6,500 lb.
9705-88902	36611	130095-0273	9.65–15.75mm (.38–.62")	0.66m (26.00")	9.525mm (.375")	Dark Green	14,400 lb.
9705-88903	36612	130095-0274	16.00–22.10mm (.63–.87")	1.219m (48.00")	11.125mm (.438")	Red	20,000 lb.
9705-88904	36613	130095-0275	22.35–28.45mm (.88–1.12")	1.524m (60.00")	12.700mm (.500")	Dark Blue	30,600 lb.
9705-88905	36614	130095-0276	28.70–34.80mm (1.13–1.37")	1.930m (76.00")	15.875mm (.625")	Yellow	46,800 lb.
9705-88906	36615	130095-0277	35.05–48.26mm (1.38–1.90")	2.261m (89.00")	19.050mm (.750")	Aluminum	66,500 lb.

Pulling Grips Multi-Weave Flexible Eye

- Galvanized Steel mesh offers superior strength
- Shoulder protectors center the grip within a raceway and provide abrasion resistance
- Color-coded for easy identification
- Wide application for bare or insulated conductors, wire rope and insulated cables for distribution line stringing and overhead transmission
- Flexible eye works in both generous and tight spaces
- Forged Steel rotating eye can reduce rotational torque whenever pulling load is reduced
- Forged Steel rotating eye will not bind when used with sheaves and blocks



Altec	Woodhead	Order No.	Cable Diameter	Mesh Length	Eye Cable Thickness	Color Code	Approximate Break Strength
9705-88907	36640	130095-0288	6.35–12.45mm (.25–.49")	0.66m (26.00")	6.350mm (.250")	Dark Green	6,800 lb.
9705-88908	36641	130095-0289	12.70–18.80mm (.50–.74")	0.813m (32.00")	7.925mm (.312")	Brown	10,000 lb.
9705-88909	36642	130095-0290	19.05–25.15mm (.75–.99")	1.041m (41.00")	9.525mm (.375")	Light Blue	14,400 lb.
9705-88910	36643	130095-0291	25.40–31.50mm (1.00–1.24")	1.321m (52.00")	12.700mm (.500")	Gold	26,600 lb.
9705-88911	36644	130095-0292	31.75–37.85mm (1.25–1.49")	1.422m (56.00")	12.700mm (.500")	Black	30,600 lb.
9705-88912	36645	130095-0293	38.10–44.20mm (1.50–1.74")	1.524m (60.00")	12.700mm (.500")	Red	30,600 lb.
9705-88913	36646	130095-0294	44.45–56.90mm (1.75–2.24")	1.778m (70.00")	15.875mm (.625")	Dark Blue	48,000 lb.
9705-88914	36647	130095-0295	50.80–63.25mm (2.00–2.49")	1.27m (50.00")	15.875mm (.625")	Yellow	48,000 lb.



Lewis Manufacturing Co.

GRIPS, HOISTS, & RIGGING

USA: 1-877-GO ALTEC
(1-877-462-5832)

www.alteconnect.com

Lewis U-Bail Grips, Tinned Bronze



These grips are used for bus drop and general suspension. These grips are constructed of **Non-Magnetic, Tin Coated Bronze**. Tin coated bronze is ideal for standard support applications under regular tension. Tin coated bronze grips should always be considered when corrosion resistance and non-magnetism are required.

U-BAIL - TB - SINGLE WEAVE							
Altec	Lewis	Description	Range	WL lbs.	UTS lbs.	Mesh	Eye
9705-88802	55-1064	U-25-SW-TB	¼" - ⅜"	325	650	5"	5½"
9705-88803	55-1065	U-37-SW-TB	⅝" - ½"	325	650	6"	5½"
9705-88804	55-1066	U-50-SW-TB	½" - ⅝"	375	750	8"	6"
9705-88805	55-1067	U-62-SW-TB	⅝" - ¾"	375	750	10"	7"
9705-88806	55-1068	U-75-SW-TB	¾" - 1½"	650	1,300	12"	8"
9704-49848	55-1069	U-100-SW-TB	¾" - 1¼"	650	1,300	14"	9"
9705-88807	55-1070	U-112-SW-TB	1⅞" - 1⅞"	675	1,350	14"	10"
9705-88808	55-1071	U-162-SW-TB	1⅞" - 2½"	750	1,500	16"	16"
9705-88809	50-2219	U-175-SW-TB	1¾" - 2½"	750	1,500	16"	16"
9705-88810	50-2691	U-200-SW-TB	2" - 2½"	850	1,700	16"	16"
9705-88811	55-1072	U-250-SW-TB	2½" - 3½"	850	1,700	18"	18"
9705-88812	55-1073	U-300-SW-TB	3" - 3½"	900	1,800	18"	18"
9705-88813	55-1074	U-350-SW-TB	3½" - 4½"	975	1,950	20"	20"
9705-88814	50-3020	U-450-SW-TB	4½" - 5½"	1,050	2,100	22"	20"

U-BAIL - TB - DOUBLE WEAVE							
Part No.	Lewis	Description	Range	WL lbs.	UTS lbs.	Mesh	Eye
9705-88815	50-4000	U-37-DW-TB	⅝" - ½"	650	1,300	6"	5½"
9705-88816	50-4001	U-50-DW-TB	½" - ⅝"	750	1,500	8"	6"
9705-88817	50-4002	U-62-DW-TB	⅝" - ¾"	750	1,500	10"	7"
9705-88818	50-4003	U-75-DW-TB	¾" - 1⅞"	1,300	2,600	12"	8"
9705-88819	50-2589	U-100-DW-TB	¾" - 1¼"	1,300	2,600	14"	9"
9705-88820	60-1493	U-112-DW-TB	1⅞" - 1⅞"	1,350	2,700	14"	10"
9705-88821	50-2766	U-162-DW-TB	1⅞" - 2½"	1,500	3,000	16"	16"
9705-88822	50-2130	U-200-DW-TB	2" - 2½"	1,700	3,400	16"	16"
9705-88823	55-1224	U-250-DW-TB	2½" - 3½"	1,700	3,400	18"	18"
9705-88824	50-4004	U-300-DW-TB	3" - 3½"	1,800	3,600	18"	18"
9705-88825	50-4005	U-350-DW-TB	3½" - 4½"	1,950	3,900	20"	20"
9705-88826	50-4006	U-450-DW-TB	4½" - 5½"	2,100	4,200	22"	20"





Lewis Manufacturing Co.

GRIPS, HOISTS, & RIGGING

USA: 1-877-GO ALTEC
(1-877-462-5832)

www.alteconnect.com

Lewis Conduit Riser Grips, LR Models

Cable Suspension in Conduits 1¼" to 6"

- Specially designed to suspend conductor by using the conduit as a means of support.
- With the conductor approximately 1/2" above the "in place" position, the grip is slipped into position and seats on the conduit edge, thus completing the installation.
- Ring size permits conduit couplings to be used.
- The ring and its components are constructed of investment cast, powder coated bronze.
- The plastic coated Aircraft Strand cable – plus the flexibility of design – permits a maximum of line surge without conductor damage.
- Patent No's. 3,216,682 and 3,399,853. Foreign and other patents are pending.



Conduit
Cut-Out View

CONDUIT SIZE	Model ▶ Range ▶	GRIP SIZE					
		0.75 ¾" - 1¼"	1.12 1¼" - 1¾"	1.62 1¾" - 2½"	2.50 2½" - 3½"	3.50 3½" - 4½"	4.50 4½" - 5½"
1¼"	Altec No. ▶ Lewis No. ▶ Description ▶ W. Load ▶	9701-18415 60-1089 LR 1¼ - .75 1,000 lbs.					
1½"		9701-18418 60-1087 LR 1½ - .75 1,000 lbs.					
2"		9701-18420 60-1091 LR 2 - .75 1,000 lbs.	9701-1842 60-1090 LR 2 - 1.12 1,250 lbs.				
* 2½"		9701-18425 60-1095 LR 2½ - .75 1,000 lbs.	9701-18428 60-1093 LR 2½ - 1.12 1,250 lbs.	9701-18429 60-1094 LR 2½ - 1.62 2,250 lbs.			
3"		9701-18434 60-1098 LR 3 - .75 1,000 lbs.	9701-18440 60-1096 LR 3 - 1.12 1,250 lbs.	9701-18442 60-1097 LR 3 - 1.62 2,250 lbs.			
‡ 3½"		9701-18454 60-1098 LR 3½ - .75 1,000 lbs.	9701-18455 60-1099 LR 3½ - 1.12 1,250 lbs.	9701-18457 60-1416 LR 3½ - 1.62 2,250 lbs.	9701-18458 55-1053 LR 3½ - 2.50 3,000 lbs.		
4"		9701-18460 60-1106 LR 4 - .75 1,000 lbs.	9701-18462 60-1103 LR 4 - 1.12 1,250 lbs.	9701-18541 60-1104 LR 4 - 1.62 2,250 lbs.	9701-18543 60-1105 LR 4 - 2.50 3,000 lbs.		
φ 4½"		9701-18544 60-1110 LR 4½ - .75 1,000 lbs.	9701-18611 60-1108 LR 4½ - 1.12 1,250 lbs.	9701-18597 60-1109 LR 4½ - 1.62 2,250 lbs.	9701-18598 60-1107 LR 4½ - 2.50 3,000 lbs.		
5"		9701-18599 60-1115 LR 5 - .75 1,000 lbs.	9701-18600 60-1111 LR 5 - 1.12 1,250 lbs.	9701-18607 60-1112 LR 5 - 1.62 2,250 lbs.	9701-18613 60-1113 LR 5 - 2.50 3,000 lbs.	9701-18754 60-1114 LR 5 - 3.50 4,500 lbs.	
§ 6"		9701-18759 60-1123 LR 6 - .75 1,000 lbs.	9701-18761 60-1118 LR 6 - 1.12 1,250 lbs.	9701-18762 60-1119 LR 6 - 1.62 2,250 lbs.	9701-18765 60-1120 LR 6 - 2.50 3,000 lbs.	9701-18773 60-1121 LR 6 - 3.50 4,500 lbs.	9701-18774 60-1122 LR 6 - 4.50 6,000 lbs.

* Maximum in 2½ inch conduit and 2 inch conductor
 ‡ Maximum in 3½ inch conduit and 3 inch conductor
 φ Maximum in 4½ inch conduit and 4 inch conductor
 § Maximum in 6 inch conduit and 5½ inch conductor



Lewis Manufacturing Co.

GRIPS, HOISTS, & RIGGING

USA: 1-877-GO ALTEC
(1-877-462-5832)

www.alteconnect.com

Lewis X-Series Grips

Single Wire Eye for Ball Bearing Swivels

X-Series Grips are made of plastic-coated or uncoated (as indicated) steel wires. They can be used overhead or for underground pulls. They incorporate a single wire bail which conforms to the tightest clearances and connects easily with either ball bearing swivels or drop forged friction swivels. The reverse weave of all X models insures that the grip and cable will pass smoothly through even the tightest blocks, sheaves, bullwheels, etc.

Lewis X Grips, Standard Duty Plastic-Coated with Metal Sleeves

The **X Grips** are used for **normal working load**. They feature metal sleeves near the top of the grip to reduce wear when pulling through clay conduit, gravel or other abrasive environments.

Also available in **Stainless Steel** and **Other Sizes**.

Part No.	Lewis	Description	Range	WL lbs.	UTS lbs.
9000-99468	50-1895	X-A-DW-24	¾"-1¼"	2,000	6,000
9000-99469	50-1904	X-B-TW-32	1¼"-2"	2,500	7,500
9000-99470	50-1910	X-C-TW-38	2"-2¾"	4,500	13,500
9000-99471	50-1993	X-D-TW-46	2¾"-3½"	5,500	16,500
9000-99472	50-1996	X-E-TW-52	3½"-4¼"	6,500	19,500
9000-99473	50-2000	X-F-TW-58	4¼"-4¾"	7,000	21,000



Lewis XS Grips, Standard Duty Plastic-Coated without Metal Sleeves

The **XS Grips** are used for **normal working load**. They do not have metal sleeves.

Also available in **Stainless Steel** and **Other Sizes**.

Part No.	Lewis	Description	Range	WL lbs.	UTS lbs.
9701-10766	50-1963	XS-A-DW-24	¾"-1¼"	2,000	6,000
9701-10781	50-1977	XS-B-TW-26	1¼"-2"	2,500	7,500
9701-10795	50-1983	XS-C-TW-32	2"-2¾"	3,500	10,500
9702-30577	50-1993	XS-D-TW-46	2¾"-3½"	5,500	16,500
9700-94961	50-1996	XS-E-TW-52	3½"-4¼"	6,500	19,500
9705-88827	50-2000	XS-F-TW-58	4¼"-4¾"	7,000	21,000



Lewis X-HDFE Grips, Heavy-Duty Uncoated with Metal Sleeves

The **Heavy-Duty X-HDFE Grips** are used for **large work loads and rugged conditions**. The heavy-duty X-HDFE models incorporate the use of exceptionally strong mesh, reverse weave, single wire bail and abrasion-resistant metal shoulders. These models are constructed of uncoated aircraft strand galvanized wire.

Part No.	Lewis	Description	Range	WL lbs.	UTS lbs.
9705-88828	50-1933	X-HDFE-¼-½	¼"-½"	1,200	6,000
9702-43197	50-1932	X-HDFE-½-¾	½"-¾"	2,400	12,000
9705-51049	50-1945	X-HDFE-¾-1¾	¾"-1¾"	5,700	28,800
9705-88829	50-1923	X-HDFE-1¾-2	1¾"-2"	9,600	48,000
9705-88830	50-1924	X-HDFE-2-2¾	2"-2¾"	11,500	56,600
9704-10534	50-1925	X-HDFE-2¾-3½	2¾"-3½"	13,500	67,200
9705-88831	50-1944	X-HDFE-3½-4¼	3½"-4¼"	15,300	76,800
9705-88832	50-1926	X-HDFE-4¼-5	4¼"-5"	17,900	86,400





Lewis Manufacturing Co.

GRIPS, HOISTS, & RIGGING

USA: 1-877-GO ALTEC
(1-877-462-5832)

www.alteconnect.com

Lewis JL-R Series Grips

For Secondary Light-Duty Cable Pulls



The **JL-R Series** is designed to be used in **secondary light duty cable pulls**. The neoprene cone at the front of the grip helps the grip and cable go around the tightest bends easily and smoothly. Once installed properly, the cone can also help eliminate possible cable lubricant migration by sealing off the end of the cable during a pull.

Part No.	Lewis	Description	Range	WL lbs.	UTS lbs.
9000-99483	50-2014	XS-JL-25-R	¼"-½"	600	1,200
9000-99484	50-2015	XS-JL-50-R	½"-¾"	1,250	2,500
9000-99485	50-2011	XS-JL-100-R	¾"-1"	1,400	2,800
9000-99486	50-2012	XS-JL-125-R	1"-1½"	2,250	4,500

Lewis OH Grips for Overhead Stringing

1/4" to 1000 MCM



The **OH Series** pulling grip is designed for the special demands of **overhead stringing crews**, with a basket constructed of woven **Nylon Coated Aircraft Strand** for maximum abrasive resistance. It has special tough **plastic boots at eye-end** to prevent abrasion between the conductor and pulling dollies. A steel thimble is manufactured into the eye and is furnished without swivel or steel thimble on request. It is easily adaptable to Lewis ball bearing swivels.

Part No.	Lewis	Description	Range	WL lbs.	UTS lbs.	Weave
9701-13450	50-1785	OH-DW-¼-½"	¼"-½"	1,500	4,500	Double
9705-88833	50-1788	OH-TW-½-¾"	½"-¾" 3/0 - .336 MCM	3,200	9,600	Triple
9000-50179	50-1790	OH-TW-¾-1"	¾"-1" .477 - .795 MCM	4,100	12,300	Triple
9702-63764	50-1791	OH-SW-1¼-1½"	1¼"-1½" .795 - 1.000 MCM	6,300	18,900	Penta

Lewis Pulling Collars

Reduce Stress On Conductors

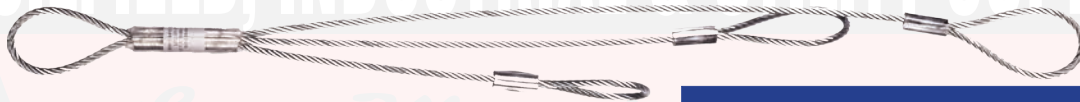

- Use the pulling collar's staggering feature to eliminate conduit stress while pulling multiple cables and grips together.
- These pulling collars allow you to attach various sized single grips together.
- The grips are attached to each collar head with a swing link or swivel.

Part No.	Lewis	Description	# of Legs	Total UTS lbs.
9000-99474	70-1006	LPC-S1-3L	3	5,500
9000-99475	70-1007	LPC-S1-4L	4	5,500
9000-99476	70-1010	LPC-S2-3L	3	8,200
9000-99477	70-1011	LPC-S2-4L	4	8,200
9000-99478	70-1014	LPC-S3-3L	3	9,800
9000-99479	70-1015	LPC-S3-4L	4	9,800

Lewis Swing Links

Drop-forged steel swing links are fabricated from the same high quality steel as Lewis Steel Swivels. They are used for adapting swivels to Lewis grips and/or winch lines.



Open

Closed

Part No.	Lewis	Description	Eye Size	Thickness
9000-99465	5118	5118	⅞"	⅝"
9000-99465	5119	5119	⅞"	⅞"
9000-99465	5120	5120	⅞"	⅞"



Lewis Manufacturing Co.

GRIPS, HOISTS, & RIGGING

**USA: 1-877-GO ALTEC
(1-877-462-5832)**

www.alteconnect.com

Lewis Pulling Grip Selection Guide for Overhead Cable Pulls

VOLTAGE CLASS	PART NUMBER	COND. SIZE AWG/KCMIL	STRANDING	NAME	NOM. O.D. IN.	RECOMMENDED LEWIS GRIP	LEWIS
Primary	9701-13450	#2	ACSR (6/1)	Sparrow	0.316	OH-DW-1/4"-1/2"	50-1785
Primary	9701-13450	#2	AAC (7)	Iris	0.292	OH-DW-1/4"-1/2"	50-1785
Primary	9701-13450	1/0	ACSR (6/1)	Raven	0.398	OH-DW-1/4"-1/2"	50-1785
Primary	9701-13450	1/0	AAC (7)	Poppy	0.368	OH-DW-1/4"-1/2"	50-1785
Primary	9701-13450	2/0	ACSR (6/1)	Quail	0.447	OH-DW-1/4"-1/2"	50-1785
Primary	9701-13450	2/0	AAC (7)	Aster	0.414	OH-DW-1/4"-1/2"	50-1785
Primary	9000-50178	4/0	ACSR (6/1)	Penquin	0.563	OH-TW-1/2"-7/8"	50-1788
Primary	9000-50178	4/0	AAC (7)	Oxlip	0.522	OH-TW-1/2"-7/8"	50-1788
Primary	9000-50178	266.8	ACSR (18/1)	Waxwing	0.609	OH-TW-1/2"-7/8"	50-1788
Primary	9000-50178	266.8	ACSR (26/7)	Partridge	0.642	OH-TW-1/2"-7/8"	50-1788
Primary	9000-50178	336.4	ACSR (26/7)	Linnet	0.721	OH-TW-1/2"-7/8"	50-1788
Primary	9000-50178	336.4	ACSR (30/7)	Oriole	0.741	OH-TW-1/2"-7/8"	50-1788
Primary	9000-50178	397.5	ACSR (26/7)	Ibis	0.783	OH-TW-1/2"-7/8"	50-1788
Primary	9000-50179	477	ACSR (18/1)	Pelican	0.814	OH-TW-7/8"-1 1/4"	50-1790
Primary	9000-50179	477	ACSR (26/7)	Hawk	0.858	OH-TW-7/8"-1 1/4"	50-1790
Primary	9000-50179	556.5	ACSR (18/1)	Osprey	0.879	OH-TW-7/8"-1 1/4"	50-1790
Primary	9000-50179	556.5	ACSR (26/7)	Dove	0.927	OH-TW-7/8"-1 1/4"	50-1790
Primary	9000-50179	605	ACSR (26/7)	Squab	0.966	OH-TW-7/8"-1 1/4"	50-1790
Primary	9000-50179	636	ACSR (26/7)	Grosbeak	0.990	OH-TW-7/8"-1 1/4"	50-1790
Primary	9000-50179	636	ACSR (30/19)	Egret	1.019	OH-TW-7/8"-1 1/4"	50-1790
Primary	9000-50179	666	ACSR (26/7)	Gannet	1.014	OH-TW-7/8"-1 1/4"	50-1790
Primary	9000-50179	715	ACSR (26/7)	Starling	1.051	OH-TW-7/8"-1 1/4"	50-1790
Primary	9000-50179	795	ACSR (26/7)	Drake	1.108	OH-TW-7/8"-1 1/4"	50-1790
Primary	9000-50179	795	ACSR (30/19)	Mallard	1.140	OH-TW-7/8"-1 1/4"	50-1790
Primary	9701-13454	954	ACSR (45/7)	Rail	1.165	X-HDFE-7/8"-1 3/8"	50-1945
Primary	9701-13454	954	ACSR (54/7)	Cardinal	1.196	X-HDFE-7/8"-1 3/8"	50-1945
Secondary	9704-65471	#2 (#4 neutral)	600V (45 mil insul.)	Cockle	0.760	XS-A-SW-24	50-1968
Secondary	9704-65471	#2	600V (45 mil insul.)	Conch	0.770	XS-A-SW-24	50-1968
Secondary	9704-65471	1/0 (#2 neutral)	600V (60 mil insul.)	Janthina	0.970	XS-A-SW-24	50-1968
Secondary	9704-65471	1/0	600V (60 mil insul.)	Neritina	0.980	XS-A-SW-24	50-1968
Secondary	9704-65471	2/0	600V (60 mil insul.)	Runica	1.080	XS-A-SW-24	50-1968
Secondary	9704-65471	3/0 (1/0 neutral)	600V (60 mil insul.)	Sanddollar	1.160	XS-A-SW-24	50-1968
Secondary	9704-65471	3/0	600V (60 mil insul.)	Cherrystone	1.190	XS-A-SW-24	50-1968
Secondary	9701-10781	4/0 (2/0 neutral)	600V (60 mil insul.)	Cuttlefish	1.270	XS-B-TW-26	50-1977
Secondary	9701-10781	4/0	600V (60 mil insul.)	Razor	1.310	XS-B-TW-26	50-1977

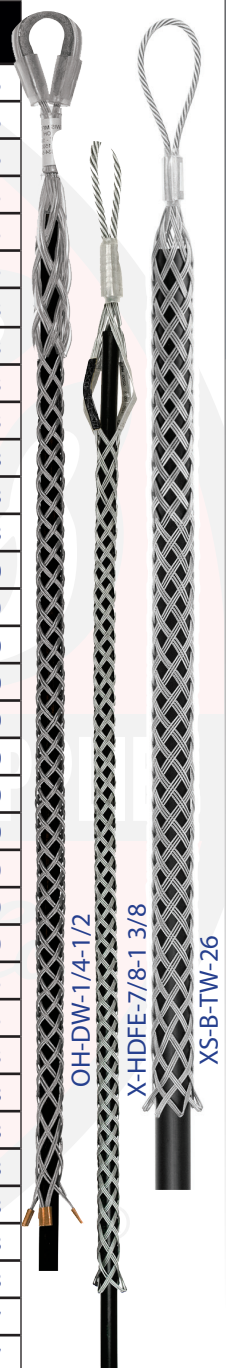



Lewis Manufacturing Co.

GRIPS, HOISTS, & RIGGING

USA: 1-877-GO ALTEC
(1-877-462-5832)

www.alteconnect.com

Lewis Sealed Directional Boring Ball Bearing Swivels

The **HD-S Sealed Directional Boring Swivels** prevent equipment's rotational torque from interfering with the product being pulled. In a typical boring application, the swivel is attached behind the reamer head and to the pipe or cable being pulled through the bore. **Permanently Sealed** to keep contaminants out, they **Never Require Lubrication**.



Part No.	Lewis	Description	WL lbs.	UTS lbs.
9000-99454	40-1003	HD-00-S	1,500	4,500
9000-99455	40-1001	HD-0-S	5,400	16,200
9000-99456	40-1005	HD-1-S	9,000	27,000
9000-99457	40-1007	HD-2-S	12,000	36,000

Lewis Heavy-Duty Ball Bearing Swivels

The **HD (Heavy-Duty) Series Swivels** are specifically designed for **tension stringing** to assure the conductor will remain in the neutral position during stringing of transmission and distribution lines. These swivels are manufactured from **high-grade pre-stressed steel**. Proper placement of thrust and radial bearing allow thrust & shock loads to be absorbed without affecting rotation of swivel. Pins are screwdriver removable.



Part No.	Lewis	Description	WL lbs.	UTS lbs.
9701-11023	40-1002	HD-00	1,500	4,500
9701-11027	40-1000	HD-0	5,400	16,200
9701-11029	40-1004	HD-1	9,000	27,000
9701-11033	40-1006	HD-2	12,000	36,000
9701-11035	40-1008	HD-3	21,000	63,000

Lewis Heavy-Duty Sealed Ball Bearing Swivels with Grease Zerk

The **HD-S-Z Sealed with Grease Zerk Swivel** is designed for **Directional Boring, overhead and underground applications** that require a **greasable swivel**. This is the high quality reliable choice. All the quality you have come to expect from the Lewis Swivel Line coupled with the greasable option.



Part No.	Lewis	Description	WL lbs.	UTS lbs.
9000-99460	40-1018	HD-0-S-Z	5,400	16,200
9000-99460	40-1019	HD-1-S-Z	9,000	27,000
9000-99460	40-1020	HD-2-S-Z	12,000	36,000
9000-99460	40-1021	HD-3-S-Z	21,000	63,000
9000-99460	40-1022	HD-4-S-Z	30,000	90,000

Please grease the swivel before & after each use.

Lewis Pull Back Knuckle Joint

The **Patent Pending Lewis Knuckle Joint** adapts a pulling swivel (or any other device) to the popular "Duckbill" style directional bits.

The **Knuckle Joint** allows the swivel to be pulled back in a straight line. This speeds up the process and reduces the amount of drag. It helps eliminate wear and tear on directional boring bits by maximizing the strength of the usable bolt size and minimizing bending of the attachment point hole. It can be ordered with either a saucer shaped deflector or the standard guard. The deflector and the guard help prevent shear loads and prevent costly pull back hangups.



Knuckle Joint installed on a "Duckbill" & connected to a HD Swivel

PATENT PENDING

Part No.	Lewis	Description
9701-14758	40-1016	LKJ-1



Lewis Manufacturing Co.

GRIPS, HOISTS, & RIGGING

Ouchless Lewis Grips™

The Ouchless Lewis Grips™ are made of plastic coated Aramid fiber strands. These popular and are widely accepted grips are traditionally used in overhead or underground operations when pulling electric or fiber optic cables.

- Non Conductive
- Lighter yet Stronger than Metal Grips
- Easier to Load & Remove
- No Wire Frays
- No Wire Cuts and Contusions

The Aramid fiber strand can be used in essentially all grip configurations. However when used around coastal areas or in corrosive environments the Stainless Steel option is still superior.

When using a pulling grip made of Aramid fibers or metal wire, always tape the bare end of the cable that will be inserted into the grip. This will eliminate a sharp edge exposure and prolong the life of your grip.



The Ouchless Lewis Grips™ do not have the metallic fraying as traditional grips do thereby eliminating the chance of being injured from metallic strands that have been abraded. Ouchless grips can also be used when a metallic grip is unsuitable, such as pulling in an energized environment.

Single Eye Models

Part No.	Lewis	Description	Range	Work Load	UTS lbs.	Weave	Mesh	Eye
9701-84660	50-2919	SE-LK-SW-¼-¾	¼"-¾"	830 lbs.	2,500 lbs.	Single	24"	4"
9701-84691	50-2920	SE-LK-SW-¾-1	¾"-1"	1,200 lbs.	3,600 lbs.	Single	24"	4½"
9701-84692	50-2921	SE-LK-SW-1-1½	1"-1½"	1,665 lbs.	5,000 lbs.	Single	44"	5"
9701-84693	50-2922	SE-LK-SW-1½-2	1½"-2"	1,940 lbs.	5,825 lbs.	Single	44"	5"
9701-84694	50-2927	SE-LK-DW-1-1½	1"-1½"	3,300 lbs.	9,900 lbs.	Double	44"	5"
9701-84695	50-2928	SE-LK-DW-1½-2	1½"-2"	3,965 lbs.	11,900 lbs.	Double	44"	5"
9701-84697	50-2929	SE-LK-DW-2-2½	2"-2½"	5,300 lbs.	15,900 lbs.	Double	44"	5"
9705-88834	50-2930	SE-LK-DW-2-3	2"-3"	5,300 lbs.	15,900 lbs.	Double	52"	5½"
9701-84700	50-2931	SE-LK-DW-3-4	3"-4"	5,300 lbs.	15,900 lbs.	Double	52"	5½"
9705-88835	50-4007	SE-LK-DW-4-4½	4"-4½"	5,888 lbs.	17,640 lbs.	Double	52"	5½"

Dual Eye Models

Part No.	Lewis	Description	Range	Work Load	UTS lbs.	Weave	Mesh	Eye
9701-84701	50-2923	DLE-LK-SW-¼-¾	¼"-¾"	830 lbs.	2,500 lbs.	Single	24"	4"
9701-84702	50-2924	DLE-LK-SW-¾-1	¾"-1"	1,200 lbs.	3,600 lbs.	Single	24"	4½"
9705-88836	50-2925	DLE-LK-SW-1¼-1½	1¼"-1½"	1,666 lbs.	5,000 lbs.	Single	24"	5"
9701-84703	50-2925	DLE-LK-SW-1-1½	1"-1½"	1,665 lbs.	5,000 lbs.	Single	44"	5"
9701-84704	50-2926	DLE-LK-SW-1½-2	1½"-2"	1,940 lbs.	5,825 lbs.	Single	44"	5"
9705-88837	50-2932	DLE-LK-DW-1¼-1½	1¼"-1½"	3,300 lbs.	9,900 lbs.	Double	24"	5"
9701-84706	50-2932	DLE-LK-DW-1-1½	1"-1½"	3,300 lbs.	9,900 lbs.	Double	44"	5"
9701-84707	50-2933	DLE-LK-DW-1½-2	1½"-2"	3,965 lbs.	11,900 lbs.	Double	44"	5"
9701-84708	50-2934	DLE-LK-DW-2-2½	2"-2½"	5,300 lbs.	15,900 lbs.	Double	48"	5"
9701-84710	50-2935	DLE-LK-DW-2½-3	2½"-3"	5,300 lbs.	15,900 lbs.	Double	48"	5"
9701-84711	50-2936	DLE-LK-DW-3-4	3"-4"	5,300 lbs.	15,900 lbs.	Double	48"	5"
9705-88838	50-4008	DLE-LK-DW-4-5	4"-5"	5,888 lbs.	17,640 lbs.	Double	52"	5"

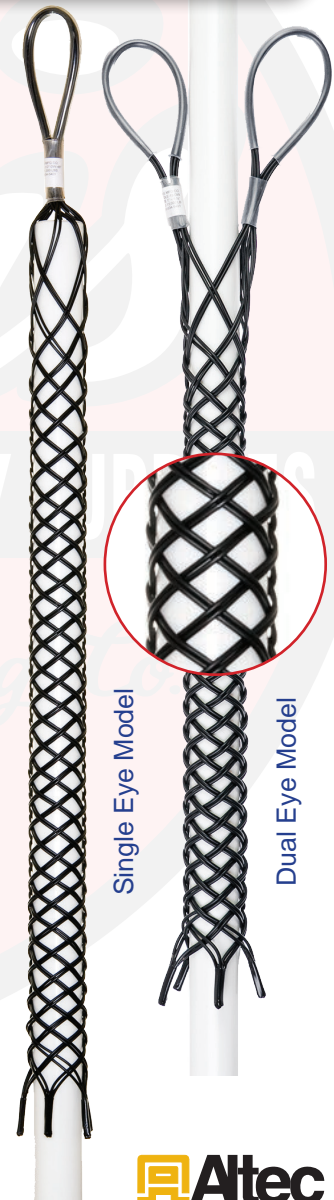

USA: 1-877-GO ALTEC
(1-877-462-5832)

www.alteconnect.com





Lewis Manufacturing Co.

GRIPS, HOISTS, & RIGGING

USA: 1-877-GO ALTEC
(1-877-462-5832)

www.alteconnect.com

Lewis Jobsite Debris Tarps

Maximum Work Load 1000 lbs.



Lewis' tarps are a convenient way of keeping the job site cleaner, saving time on back-fills. The tarps are made of **Heavy-Duty, Heat-Selaeed Rubberized Canvas**. Equipped with lifting handles. The tarp can be filled with dirt or other worksite debris. The handles, made of tough tubular nylon webbing, can be used to lift the tarp using a crane or other similar devices for **backfilling or taking the debris away**.

WARNING

DROP/CRUSH HAZARD, Never stand under a tarp when moving dirt or debris. DO NOT EXCEED the recommended Maximum Work Load



Lewis Rowdy's DirtBall™

Rowdy's DirtBall models come in two configurations in a variety of sizes and colors to suit your needs. The V-notch models allow you to get the tarp even closer to your work.



DirtBall in Action Installing a Utility Pole

Part No.	Lewis	Description	Size	WL lbs.	Canvas	Notch
9705-88839	90-2000	RDB-6x6-18	6' x 6'	1,000	18 oz.	-
9705-88840	90-2001	RDB-7x7-18	7' x 7'	1,000	18 oz.	-
9705-88841	90-2002	RDB-8x8-18	8' x 8'	1,000	18 oz.	-
9705-88842	90-2006	RDB-6x6-18V	6' x 6'	1,000	18 oz.	V
9705-88843	90-2007	RDB-7x7-18V	7' x 7'	1,000	18 oz.	V
9705-88844	90-2008	RDB-8x8-18V	8' x 8'	1,000	18 oz.	V
9705-88845	90-2003	RDB-6x6-22	6' x 6'	1,000	22 oz.	-
9705-88846	90-2004	RDB-7x7-22	7' x 7'	1,000	22 oz.	-
9705-88847	90-2005	RDB-8x8-22	8' x 8'	1,000	22 oz.	-
9705-88848	90-2009	RDB-6x6-22V	6' x 6'	1,000	22 oz.	V
9705-88849	90-2010	RDB-7x7-22V	7' x 7'	1,000	22 oz.	V
9705-88850	90-2011	RDB-8x8-22V	8' x 8'	1,000	22 oz.	V

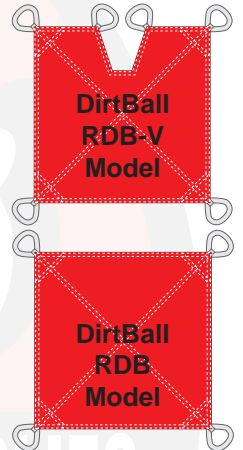

Lewis Rowdy's Auger Tarp



The Auger Tarp is similar to Rowdy's DirtBall but has a center opening. One side of the tarp has an overlapping slit that allows the tarp to be installed or removed from around a pole to keep the jobsite cleaner while digging. The overlapping slit on the side is secured using hook-loop closures and **Heavy-Duty Quick Release** buckles.

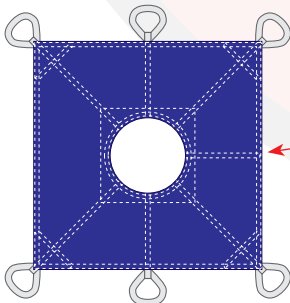

Overlapping Slit with Hook-Loop Fastener & Quick Release Buckles

Part No.	Lewis	Description	Size	WL lbs.	Canvas	Hole Dia.
9705-88851	90-2015	RDB-A18-6x6-18	6' x 6'	1,000	18 oz.	18"
9705-88852	90-2016	RDB-A24-6x6-18	6' x 6'	1,000	18 oz.	24"
9705-88853	90-2017	RDB-A18-6x6-22	6' x 6'	1,000	22 oz.	18"
9705-88854	90-2018	RDB-A24-6x6-22	6' x 6'	1,000	22 oz.	24"
9705-88855	90-2019	RDB-A24-7x7-18	7' x 7'	1,000	18 oz.	24"
9705-88856	90-2020	RDB-A30-7x7-18	7' x 7'	1,000	18 oz.	30"
9705-88857	90-2021	RDB-A24-7x7-22	7' x 7'	1,000	22 oz.	24"
9705-88858	90-2022	RDB-A30-7x7-22	7' x 7'	1,000	22 oz.	30"
9705-88859	90-2023	RDB-A30-8x8-18	8' x 8'	1,000	18 oz.	30"
9705-88860	90-2024	RDB-A36-8x8-18	8' x 8'	1,000	18 oz.	36"
9705-88861	90-2025	RDB-A42-8x8-18	8' x 8'	1,000	18 oz.	42"
9705-88862	90-2026	RDB-A30-8x8-22	8' x 8'	1,000	22 oz.	30"
9705-88863	90-2027	RDB-A36-8x8-22	8' x 8'	1,000	22 oz.	36"
9705-88864	90-2028	RDB-A42-8x8-22	8' x 8'	1,000	22 oz.	42"



Lewis Manufacturing Co.

GRIPS, HOISTS, & RIGGING

Lewis Heavy-Duty Bulk-Bag™

Maximum Work Load 3000 lbs.

Hi-Capacity, Heavy-Duty, 3000 lbs.

With 47 Cubic Feet of Secure Storage, Lewis

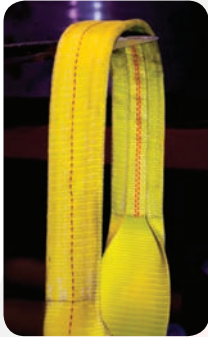

High-Strength 4" Wide Reinforced Lifting Straps

Bulk-Bag™ is ideal for storing or organizing your equipment and heavy-duty debris removal. The bag keeps your valuable gear organized and helps to reduce cluttered trip hazards. Also it is excellent for debris removal or storage.



Can be moved with a forklift thus reducing lifting & back injuries.

Part No.	Lewis	Description
9705-94905	90-2031	90-2031

LEWIS BULK-BAG SPECIFICATIONS:

- Heavy-Duty 22 oz. Vinyl-Coated Nylon
- 3000 lbs. Maximum Load Capacity
- Bag measures 44" x 44" x 42" high with a volume of 47 cubic feet or 1.74 cubic yards
- 24" high, 4" Wide High-Strength Nylon Webbing Lifting and Support Straps
- 2" Top Rim High-Strength Nylon Web Reinforcement
- Double-Layered Bottom for extra strength
- **NOT for use with liquids**



2" Rim Web Reinforcement

⚠ WARNING

1. **STAY CLEAR WHEN TRANSPORTING A LOADED BULK BAG.**
2. Do not allow personnel or equipment beneath the bulk bag at any time, this is a **DROP/CRUSH HAZARD**.
3. Do not alter, cut or modify this bulk bag in any way.
4. Do not use the bulk bag for hoisting personnel. This is **NOT A PERSONNEL LIFT** device.
5. Carefully inspect the straps and nylon material before each use for any signs of wear.
6. Do not place sharp objects in bulk bag.
7. Remove the bulk bag from service immediately if it has any rips or tears or if it has torn seams.
8. All Support / Lifting straps must be on the outside of bag before use.
9. Do not expose the bulk bag to any heat source. This bag is not fire proof.
10. Do not transport liquids, as the bag is not watertight.
11. If you do not understand how to properly use this bulk bag, ask your supervisor.



DANGER
FALLING OBJECTS



WARNING
NOT A PERSONNEL LIFT

USA: 1-877-GO ALTEC
(1-877-462-5832)

www.alteconnect.com

PULLING EYES

- Facilitates safe, fast installation of guy-grip dead-ends at the anchor rod
- Constructed of corrosion resistant nodular iron
- Large eye is offset to position the hook of the chain hoist safely to one side and permit easy, uncrowded application of the dead-end
- Eye is adjustable for rod size

P/N 9007-03000 - 3,000 lb. Working Load
P/N 9007-00096 - 6,000 lb. Working Load



CHAIN SLINGS & LIFTING ACCESSORIES

Chain Slings



G = Clevis Grab Hook
O = Master Ring
L = Lock-pin Coupling Link
W = Welded Coupling Link

- All slings use 1/2" Grade 80 alloy chain
- Maximum rated working load is 12,000 lbs.
- Available in various lengths and attachments

P/N	Length	1st End	2nd End
8938-82850	3'	7/8" O	5/8" W
8938-82851	2'	7/8" O	5/8" W
8938-82852	7'	7/8" O	5/8" W
8938-82853	9'	3/4" O*	1/2" G
8938-82854	10'	3/4" O*	1/2" G
8938-82855	15'	3/4" O*	1/2" G
8939-31370	25'	1/2" G	1/2" G
8939-31380	10'	1/2" G	1/2" G
8939-31390	22'	5/8" L*	5/8" L*

* Connected to chain with Lock-pin Coupling Link

For custom lengths or attachments call 1-877-GO ALTEC (1-877-462-5832)

DCD Wire Rope Bridle Sling

- Allows multiple simultaneous pulls by attaching 2, 3 or 4 cables or ducts to the puller
- Features aircraft quality wire rope
- Various "legs" are staggered in length to prevent the individual connections from interfering with each other
- The lead coupler can be dismantled to change out a leg or to add another leg
- Each leg is marked with load capacity and they are pull tested to 3 times that rating
- The safety factor of 3:1 is based on equal pull on all cables (horizontal pull only)

P/N 9701-57566 23375-030 3/8" Wire Diameter 3 legs 14,400 lb. Capacity



6 x 19 IWRC Cable



- Utilizes the Flemish eye splice, which is secured by a metal sleeve
- Designed for use as a choker
- Highest rated capacity of any spliced sling
- 1.6 ton capacity
- Sliding choker for better adjustment
- Wide range of sizes and lengths available

P/N 9702-13365 4' Length
P/N 9700-71857 7' Length

Steel Choker with Loops on Both Ends



- Eye and eye wire rope sling
- Wire rope construction is 6 x 19, IWRC, Right Regular Lay (industry standard)

P/N 9000-12400	1/2" x 4'
P/N 9000-12600	1/2" x 6'
P/N 9000-12800	1/2" x 8'
P/N 9000-38400	3/8" x 4'
P/N 9000-38600	3/8" x 6'
P/N 9007-38800	3/8" x 8'

Available in Numerous Sizes

3/8" Pole Sling with Slide Hook



- Will not kink like cable or fray like rope
- Slides down pole easily
- Fittings are grade 8 alloy
- 4 - 1 design factor
- 5' long

P/N 9700-42903

2 Ply Nylon Slings

- Capacities: Vertical is 6,400 lbs.; Basket hitch - 12,800 lbs.; Choker - 5,000 lbs.
- Capacities are determined according to ANSI standard B30.9, Section 9-5.2
- Industry standard twisted eye and eye nylon web sling

P/N 9000-28024 2" x 4' Nylon Sling
P/N 9000-28026 2" x 6' Nylon Sling
P/N 9000-28028 2" x 8' Nylon Sling



CHAIN SLINGS & LIFTING ACCESSORIES

Tuflex Endless Gel Round Slings



- 10' long
- Load stability and balance achieved by spreading sling legs
- Wear points may continually be shifted for maximum sling life

CAPACITIES

	<u>Vertical</u>	<u>Choker</u>	<u>Basket</u>
P/N 9700-92102	10,600 lbs.	8,500 lbs.	21,200 lbs.

Tuflex Endless Polyester Round Slings



P/N 9700-71858

P/N 9700-71860

- 6' long
- Light, versatile, flexible synthetic slings
- Wear points may continually be shifted for maximum sling life

CAPACITIES

	<u>Vertical</u>	<u>Choker</u>	<u>Basket</u>
P/N 9700-71858	2,650 lbs.	2,120 lbs.	5,300 lbs.
P/N 9700-71860	5,300 lbs.	4,240 lbs.	10,600 lbs.

Utility Pole Specialized Rigging Sling

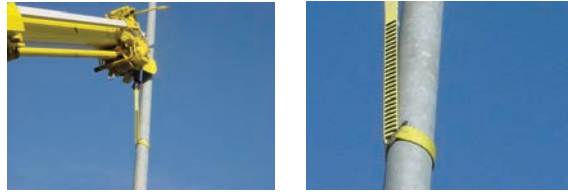

- 70" working length
- 1,900 lb. rated capacity
- Designed to offer a good grip on the shaft of a tapered pole without rigging up a clamping device
- Designed by bonding patented slip-resistant polymer traction bars to a nylon sling, using a proprietary process
- When slipped around a pole and pulled taught, its polymer grippers are forced into the surface of the pole; more force produces an even tighter grip
- Saves time and manpower, because now crews can simply pick a spot anywhere above the pole's "tipping point," fasten the sling, and be ready to lift

P/N 9701-97787

Polyester Web Slings



- A light, versatile, flexible synthetic sling with eyes on both ends
- Wear points can continually be shifted for maximum sling life
- Vertical capacity: 3,200 lbs.
- Choker capacity: 2,500 lbs.
- Basket capacity: 6,400 lbs.

P/N 234-80005 1" Wide x 9' Long

P/N 234-80004 1" Wide x 10' Long

TRANSFORMER SLINGS

Hastings Transformer Slings

Altec	Hastings	Description
9701-55186	06-178	34" Transformer Sling
9701-55188	06-179	38" Transformer Sling
9700-92015	06-180	48" Transformer Sling, 2" Wide Web; 3 Steel Triangles



Transformer Slings

- Features eye on each end
- Adjustable from 3" to 15" to accommodate various sizes and types of transformers
- Chafe collar in middle of sling protects against abrasion and snagging
- Each end has a crown splice to prevent eye from pulling out while under load
- Standard length is 4 ft.; other lengths available
- Adjustable from 24" to 28"
- Rope is 100% high tenacity polyester, constructed in a single braid and coated with Rhino-Lote for increased abrasion resistance

Altec P/N	Diameter	Vertical Lift	Basket Lift	Color
9705-71112	1/2" Diameter	2,200 lbs.	4,400 lbs.	Blue
9705-71115	5/8" Diameter	3,200 lbs.	6,400 lbs.	Red
9705-71116	3/4" Diameter	4,200 lbs.	8,400 lbs.	Green



GRIPS, HOISTS, & RIGGING

USA: 1-877-GO ALTEC
(1-877-462-5832)

www.alteconnect.com

Campbell®

ALLOY SUPERIOR STRENGTH

Campbell's Portfolio of anchor shackles is now even more robust. Our new line of mid to large sizes of Screw Pin and Bolt Type Anchor Shackles features innovative design changes in our forgings to meet growing industry needs.

- Proudly made in the USA
- Alloy Shackles meet all requirements for CE Compliance
- Bows, Pins, and Bolts are galvanized to ASTM A-153 specifications
- Meet or exceed all manufacturing requirements of ASME B30.26
- Meet design requirements of federal specification RR-C-271F, Type IVA for Class 2 and Class 3
- Drop forged for superior strength and performance
- 5:1 design factor
- Working Load Limit (WLL) rated in metric tons (t)



Screw Pin Style

Bolt Style (shown left) is available. Please call 1-877-GO ALTEC (1-877-462-5832) for more information.



Radial draft design increases cross-sectional area of the shackle ear for greater strength while improving fit and function between the pin and shackle body.

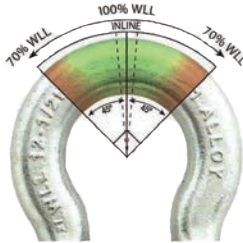

Lettering placement is strategically located to avoid top of shackle bow to prevent fraying of synthetic slings.

Included angle between markings provides a quick visual guide for checking the load angle for double and single leg hitches.

Date code, "WLL" (Working Load Limit), and Size are permanently forged on one side of shackle bow while "Campbell," "USA," and "CE" are permanently forged on the opposite side.

Campbell®

Alloy Screw Pin Anchor Shackles, Galvanized, A-419-G

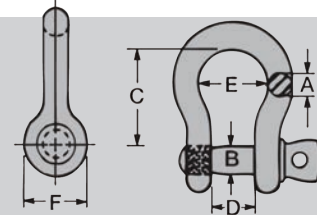

TRADE SIZE	ALTEC	CAMPBELL	WORKING LOAD LIMIT (METRIC TONS)	LENGTH TOLERANCE (+/-)	WIDTH TOLERANCE (+/-)	B DIMENSIONS	C DIMENSIONS	D DIMENSIONS	E DIMENSIONS	F DIMENSIONS	WEIGHT EACH (LBS.)
3/8"	9706-37581	5410695	2 T	1/8"	1/16"	7/16"	1-7/16"	21/32"	31/32"	15/16"	0.31 lbs.
1/2"	9706-37582	5410895	3-1/3 T	1/8"	1/16"	5/8"	1-15/16"	13/16"	1-1/4"	1-1/4"	0.70 lbs.
5/8"	9706-37583	5411095	5 T	1/8"	1/16"	3/4"	2-3/8"	1-1/16"	1-11/16"	1-1/2"	1.40 lbs.
3/4"	9706-37584	5411295	7 T	1/4"	1/16"	7/8"	2-13/16"	1-1/4"	1-13/16"	1-3/4"	2.00 lbs.
7/8"	9706-37585	5411495	9-1/2 T	1/4"	1/16"	1"	3-5/16"	1-7/16"	2-9/32"	2-3/32"	3.60 lbs.
1"	9706-37586	5411695	12-1/2 T	1/4"	1/16"	1-1/8"	3-3/4"	1-11/16"	2-1/2"	2-3/8"	5.70 lbs.
1-1/4"	9706-37587	5412095	18 T	1/4"	1/16"	1-3/8"	4-1/2"	2"	3-1/4"	3"	10.50 lbs.
1-3/8"	9706-37588	5412295	21 T	1/4"	1/8"	1-1/2"	5-1/4"	2-1/4"	3-5/8"	3-5/16"	13.30 lbs.
1-1/2"	9706-37589	5412495	30 T	1/4"	1/8"	1-5/8"	5-3/4"	2-3/8"	3-7/8"	3-5/8"	18.90 lbs.
2"	9706-37590	5413295	55 T	1/4"	1/8"	2-1/4"	7-3/4"	3-1/4"	5-3/4"	4-7/8"	50.00 lbs.

- Shackle Bodies Are Drop-Forged Alloy Steel
- Galvanized to Meet ASTM A-153 Specifications
- A-419-G Shackles Meet the Design Requirements of Federal Specification RR-C-271, Type IVA, Grade B, Class 2
- A-999-G Shackles Meet the Design Requirements of Federal Specification RR-C-271, Type IVA Grade B, Class 3
- Statistically Tested for Impact Resistance, Tensile Strength, Hardness, Ductility and Fatigue
- Working Load Limit, Size, Manufacture Name, Date Code and USA Permanently Marked on Each Shackle
- Certification Available Upon Request

- 5 to 1 Design Factor
- Pins and Bolts Are Heat-Treated and Made of Alloy Steel
- 419 and 999 Series Shackles Meet or Exceed All Manufacturing Requirements of the ASME B30.26 "Rigging Hardware". These Include the Material Ductility Requirement (Section 26-1.1.2), the Design Factor Requirement (Section 26.1.2), the Identification Requirement (Section 26-1.5.1), and the Effective Temperature Range (Section 26-1.6.1). the Shackles Can Be Proof Tested in Accordance with Section 26-1.4
- DO NOT EXCEED THE WORKING LOAD LIMIT

Campbell®

Campbell's Portfolio of anchor shackles is now even more robust. Our new line of mid to large sizes of Screw Pin and Bolt Type Anchor Shackles features innovative design changes in our forgings to meet growing industry needs.



- Shackle Bodies Are Drop-Forged Carbon Steel
- Self Colored (Painted Blue)
- C-419-S Shackles Meet the Design Requirements of Federal Specification RR-C-271, Type IVA, Grade A, Class 2
- Working Load Limit, Size, Manufacture Name, Date Code and USA Permanently Marked on Each Shackle
- Statistically Tested for Impact Resistance, Tensile Strength, Hardness, Ductility and Fatigue
- 419 Series Shackles Meet or Exceed All Manufacturing Requirements of the ASME B30.26 "Rigging Hardware". These Include the Material Ductility Requirement (Section 26-1.1.2), the Design Factor Requirement (Section 26.1.2), the Identification Requirement (Section 26-1.5.1), and the Effective Temperature Range (Section 26-1.6.1). the Shackles Can Be Proof Tested in Accordance with Section 26-1.4
- Certification Available Upon Request
- 6 to 1 Design Factor
- Pins and Bolts Are Heat-Treated and Made of Alloy Steel
- DO NOT EXCEED THE WORKING LOAD LIMIT

CARBON

Campbell®

Carbon Screw Pin Anchor Shackles, Self-Colored, C-419-S

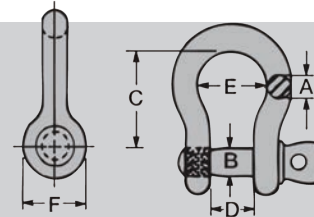

TRADE SIZE	ALTEC	CAMPBELL	WORKING LOAD LIMIT (SHORT TONS)	LENGTH TOLERANCE (+/-)	WIDTH TOLERANCE (+/-)	B DIMENSIONS	C DIMENSIONS	D DIMENSIONS	E DIMENSIONS	F DIMENSIONS	WEIGHT EACH (LbsS.)
1/4	9706-40814	5410405	1/2 T	1/16"	1/16"	5/16"	1-1/8"	15/32"	25/32"	11/16"	0.10 lbs.
5/16	9706-40815	5410505	3/4 T	1/16"	1/16"	3/8"	1-1/4"	17/32"	27/32"	3/4"	0.20 lbs.
3/8	9706-40816	5410605	1 T	1/8"	1/16"	7/16"	1-7/16"	21/32"	31/32"	15/16"	0.30 lbs.
7/16	9706-40817	5410705	1-1/2 T	1/8"	1/16"	1/2"	1-3/4"	23/32"	1-5/32"	1-1/8"	0.52 lbs.
1/2	9706-40818	5410805	2 T	1/8"	1/16"	5/8"	1-15/16"	13/16"	1-1/4"	1-1/4"	0.80 lbs.
5/8	9706-40819	5411005	3-1/4 T	1/8"	1/16"	3/4"	2-7/16"	1-1/16"	1-9/16"	1-7/16"	1.50 lbs.
3/4	9706-40820	5411205	4-3/4 T	1/4"	1/16"	7/8"	2-13/16"	1-1/4"	1-13/16"	1-3/4"	2.00 lbs.
7/8	9706-40821	5411405	6-1/2 T	1/4"	1/16"	1"	3-1/8"	1-7/16"	2-1/16"	2"	3.20 lbs.
1	9706-40822	5411605	8-1/2 T	1/4"	1/16"	1-1/8"	3-3/4"	1-11/16"	2-1/2"	2-3/8"	5.00 lbs.
1-1/8	9706-40823	5411805	9-1/2 T	1/4"	1/16"	1-1/4"	4-1/4"	1-13/16"	2-15/16"	2-5/8"	7.00 lbs.
1-1/4	9706-40824	5412005	12 T	1/4"	1/16"	1-3/8"	4-1/2"	2"	3-1/4"	3"	10.00 lbs.
1-3/8	9706-40825	5412205	13-1/2 T	1/4"	1/8"	1-1/2"	5-1/4"	2-1/4"	3-1/2"	3-1/4"	13.00 lbs.
1-1/2	9706-40826	5412405	17 T	1/4"	1/8"	1-5/8"	5-3/4"	2-3/8"	3-7/8"	3-1/2"	16.00 lbs.
1-3/4	9706-40827	5412805	25 T	1/4"	1/8"	2"	7"	2-7/8"	4-3/4"	4"	26.00 lbs.
2	9706-40828	5413205	35 T	1/2"	1/8"	2-1/4"	7-3/4"	3-1/4"	5-3/4"	4-7/8"	41.00 lbs.

USA: 1-877-GO ALTEC
(1-877-462-5832)

www.alteconnect.com



Columbus McKinnon Screw Pin Midland Carbon Anchor Shackle



- Screw Pin Anchor/Chain Shackles allow quick and easy removal of the screw pin and can be useful in applications where the shackle is frequently removed, but not so much in applications where the pin is subject to torque or twisting
- Meet requirements of Federal Specification RR-C-271D Amendment 1
- All shackle pins are forged from alloy steel, heat treated and tempered to give greater strength
- Available in painted, galvanized and self-colored finishes (Dacromate coating upon special request only)
- All shackles are marked with size (inches and millimeters) and working load limit in tons
- Ultimate strength equals 5 times working load limit

- All bolt, nut & cotter shackles have thread protected ends
- Galvanized per ASTM A153
- Standard industry tolerances apply
- Design factor 5:1
- Pin Type: Screw

Part Number	CM	Working Load Limit
P/N 9703-66345	MC649	1 1/2 Ton
P/N 9703-66346	MC650	2 Ton
P/N 9703-66347	MC651	3 1/4 Ton
P/N 9703-66348	MC652	4 3/4 Ton
P/N 9703-66349	MC654	8 1/2 Ton

Columbus McKinnon Carbon Web Sling Shackle



- Designed for use with web slings up to 6" in width and available in capacities up to 12 tons
- Finish: hot dip galvanized
- Klik pin (zinc plated) as shown furnished as standard-cotter or hair pin can be furnished on special order

- Shackle body: carbon steel, heat treated
- Shackle pin: alloy steel, heat treated
- Tolerances: 11/32" unless otherwise indicated
- Design ultimate strength equals 4 times the working load limit

Part Number	CM	Size	Webbing Width	Working Load Limit
P/N 9703-66350	M702	5/8"	2"	8,050 lbs.
P/N 9703-66351	M703	3/4"	3"	13,050 lbs.
P/N 9703-66352	M704	3/4"	4"	10,800 lbs.
P/N 9703-66353	M705	7/8"	5"	18,000 lbs.
P/N 9703-66354	M706	1"	6"	18,000 lbs.

Columbus McKinnon Alloy Web Sling Shackle



- Designed for use with web slings up to 6" in width and available in capacities up to 12 tons
- Web Sling Shackles can be used on web slings from 3 to 6 inches in width
- Utilize a bolt and nut with linch style pin to secure the assembly in place

- Galvanized for longer life
- Marked with working load limit (WLL) and size
- Pin Type: Bolt, Nut and Cotter

Part Number	CM	Size	Working Load Limit
P/N 9703-66356	M703A	3/4"	13,500 lbs.
P/N 9703-66357	M704A	3/4"	14,500 lbs.
P/N 9703-66358	M705A	1"	19,000 lbs.
P/N 9703-66359	M706A	1-1/8"	22,500 lbs.

Crosby Screw Pin Shackles



- Working load limit permanently shown on every shackle
- Forged - quenched and tempered, with alloy pins
- Self-colored
- Fatigue rated

P/N 9000-99580	1018446	7/16"	1 1/2 Ton Capacity, 1/2" Pin
P/N 9007-10184	1018464	1/2"	2 Ton Capacity, 5/8" Pin
P/N 9000-99581	1018482	5/8"	3 1/4 Ton Capacity, 3/4" Pin
P/N 9000-99582	1018507	3/4"	4 3/4 Ton Capacity, 7/8" Pin
P/N 234-21005	1018523	7/8"	6 1/2 Ton Capacity, 1" Pin

BLOCKS



Campbell® Nylon Blocks for Manila Rope

- Nylon Shells and Sheaves
- Single 3101F, Double 3102F
- Fittings Are Drop-Forged
- Plated Strap and Connections
- Working Loads are Resultant Working Loads
- DO NOT EXCEED THE WORKING LOAD LIMIT

Altec	Campbell	Block Size	Number of Sheaves	Fitting Type	Rope Diameter	Sheave Size - OD	Sheave Size - Time Thickness	Bearing Diameter	Sheave Size - Center Pin Diameter	Working Load Limit	Weight Each (lbs.)
9705-16571	7222213	2"	Double	Flat Eye Loose Hook "F"	3/8" - 1/2"	2"	1-1/8"	5/8"	3/8"	1000 lb.	1.22 lb.
9705-16570	7220214	2"	Single	Swivel Hook with Latch "G"	3/8" - 1/2"	2"	1-1/8"	5/8"	3/8"	500 lb.	0.44 lb.
9705-16572	7222214	2"	Double	Swivel Hook with Latch "G"	3/8" - 1/2"	2"	1-1/8"	5/8"	3/8"	1000 lb.	1.60 lb.

Campbell® 3" Aluminum Alloy Handline Block

- Best in Class - 1,500 lb. working load
- 3:1 load safety design factor
- Lightweight aluminum alloy construction
- 3" permanently lubricated sheave
- Up to 5/8' rope capacity

P/N 9706-37557 7380303



Campbell® 3" Fiberglass-Nylon Handline Block

- 1,000 lb. working load
- 3:1 load safety design factor
- Lightweight fiberglass body
- 3" permanently lubricated sheave
- Up to 5/8' rope capacity

P/N 9704-98440 7380300



Crosby Snatch Blocks

- Hook and shackle assemblies can be interchanged
- Opening feature permits insertion of rope while block is suspended from gin-pole
- Blocks have exclusive bolt retaining spring to assure no lost bolts
- Forged alloy heat treated hooks
- Forged steel swivel tees, yokes and shackles
- Furnished with bronze bushings
- Pressure lube fittings
- May be furnished with a hook latch
- Feature dual rated wireline sheaves
- Fatigue rated



Part Number	Model	Sheave Diameter	Capacity
P/N 9701-52119	108038	3"	2 Ton Capacity
P/N 9000-99578	108065	4 1/2"	4 Ton Capacity
P/N 9000-99579	108127	6"	8 Ton Capacity
P/N 9701-57619	108225	8"	8 Ton Capacity

Handline Block

- Fiberglass reinforced nylon construction
- 1000 lb. working load
- Pull pin with detent ball for easy opening and securing
- Safety orange
- Open body design for easy rigging
- 3" sheave, 5/8" rope capacity
- Swivel eye allows 360° rotation

P/N 9700-57425



BLOCKS



Chance Block with Insulated Rope

- Shells and sheaves are made of high dielectric, fiber-filled natural nylon
- Shaft is of silicon bronze and the sheave bearings are oil impregnated bronze
- Dielectric rating in dry weather is 30,000 volts between the bearing and the mounting bolt nut
- Maximum 1/2" rope
- Maximum load is 3,500 lb. for both double and triple blocks

P/N 9000-40919 C4009019 Double Block with Becket
P/N 9000-00918 C4000918 Triple Block without Becket

Chance Double Nylon Rope Blocks

- The shells and sheaves are made of high dielectric, fiberfilled natural nylon
- Shaft is made of silicon bronze and sheave bearings are oil impregnated bronze
- Maximum 1/2" rope
- Blocks available with either polypropylene or Poly-Dacron rope for minimum stretch and long service life
- Dielectric Strength: Dielectric rating in dry weather is 30,000 volts between the bearing and the mounting bolt nut



P/N 9700-53521 C4000925 Double/Triple Blocks Set; 150' Rope
P/N 9700-53555 C4000924 Double Blocks Set; 120' Rope



Chance Snatch Blocks

- Light-weight cast-aluminum housing and sheave with a hinged, cotterlock yoke and either forged steel or steel meat hook, makes for quick, easy rigging in diversified applications
- Handline and block and tackle efficiency is increased with a forged steel swivel-eye suspension ring and a 3" sheave operating on bronze oilite bearings
- Maximum rope size is 5/8"
- Maximum load capacity is 1,250 lb.

P/N 9700-53519 2230-1 Single Block 1,250 lb. Capacity

Hand Line Block, Safety Orange

- 1,000 lb, working load
- Safety orange color
- Fiberglass reinforced nylon body and sheave
- Side-opening body design for easy rigging
- 3" diameter sheave accepts up to 5/8" diameter rope
- Plated steel swivel eye allows 360 degree orientation
- Plated forged steel hook has 3/4 throat opening, plus spring-loaded safety latch
- Side-opening design includes high-strength detent ball pin that is easy to remove and is secured to body with a lanyard

P/N 9702-46424 PSC4033478 1,000 lb. Working Load
P/N 9702-46425 PSC4033479 Lanyard & Pin Kit
P/N 9705-67208 PSC4033480 Spring Latch Kit



USA: 1-877-GO ALTEC
(1-877-462-5832)

www.alteconnect.com

Please contact 1-877-GO ALTEC (1-877-462-5832)
for additional information regarding Chance products.

ALTEC SUPPLY Stringing Block

- Latch is positive locking and can be opened and closed easily with a hot stick
- Frame is "I Beam" design and will support the rated load with the gate open
- Weighs 10 lbs.
- 2,500 lb. rated work load

P/N 9703-48641 Stringing Block
 P/N 9703-48647 CrossArm Bracket
 P/N 9703-48648 Wide Yoke
 P/N 9703-48649 Clevis Yoke



Bethea BTTV Convertible Series Travelers Stringing Blocks

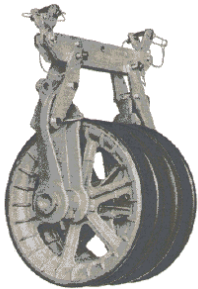

- Polished aluminum; urethane lining
- Safe working load is based on single resultant vertical load on center (pulling line) sheave
- P/N 9000-31181 features a working load of 15,000 lbs.
- P/N 9000-31148 features a working load of 8,000 lbs.
- The ultimate in cost efficiency
- Major load supporting members are alloy
- Precision ground, deep-groove Conrad type shielded ball bearings increase the efficiency of each traveler, and simplify the sagging operation
- Urethane of the highest grade and of the proper hardness is used for lining the conductor sheaves
- Pulling line sheaves are lined with high strength, wear-resistant urethane which under normal use outlasts most steel and iron linings
- These components are secured to the traveler with welded closed link chain
- Safe rapid attachment to supporting hardware is accomplished with captive pushbutton ball lock pins or safety pins
- All ferrous components are protected from corrosion, depending on application by hot dip galvanized, electro-cadmium plating, or rust-inhibiting enamel

P/N 9000-31181 BTTV-31-UL18-12 22" diameter
 P/N 9000-31148 BTTV-31-UL14-8 16" diameter

Bethea Stringing Block



- Shaft is high strength A356 alloy steel (.668" diameter) - twice the strength of a 1/2" bolt
- Latch is positive locking and can be opened and closed easily with a hot stick
- Frame is "I Beam" design and will support the rated load with the gate open
- Weighs 9.4 lbs.
- 2,500 lb. rated work load

P/N 9700-44378

Pole Top Block with Screw Pin Adapter



- Ideal for light duty
- Equipped with two polished all-aluminum alloy rollers to support the conductor during straight stringing and angles up to 10°
- Features a clamp top to keep the wire or pulling line from coming out where an uplift exists
- Limited use block
- Fits down onto standard NEMA pins 1" to 1 3/8" and with adapter will screw directly onto standard 1" NEMA pin

P/N 9700-92171

Stringing Controller with Reel & Rope

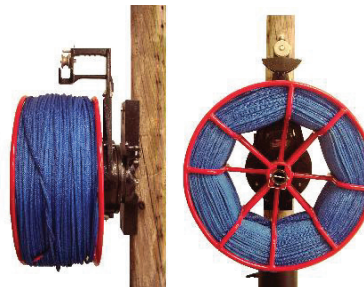

- Durable steel reel
- Capacity: 3000' of 5/16" poly plus pilot line
- Parts are interchangeable with other popular brands
- Eliminates the need for finger lines, which prevents the need to tie and untie the pilot lines
- This system saves time by preventing extra climbs and keeps the pilot lines safe from vandalism
- Complete system consists of a controller, a light-weight reel with 3000' of 5/16" Poly Plus rope available in black, red, green, or blue (may also be purchased separately)

P/N 9701-19305

STRINGING EQUIPMENT

AT75 Pilot Line Controller by **ALASKAUG AUGERS** by Auger Tech



Auger Tech Pilot Line Controllers were invented, patented, and manufactured by Alaskaug in the 1960's for installation of overhead pulling lines.

The Auger Tech Pilot Line System consists of a positive braking controller and a storage reel of rope, which mount on the lead pole at any desired height. This unique system saves labor and eliminates dangling "finger lines".



P/N 9706-37407	AT-75C S-75	Controller for 3000' Reel and Rope
P/N 9706-37408	AT-75-SR AT-75	Storage Reel for 3000' of Rope
P/N 9706-37409	AT-75 3000	Rope 3000' - 5/16" Braided Rope
P/N 9706-37410	AT-75CRR	AT-75 Pilot Line Controller, Reel W/Rope
P/N 9706-37411	AT85 C	Controller for 6000' Reel and Rope
P/N 9706-37412	AT85 SR	Fabricated Steel Reel for 6000' of Rope
P/N 9706-37413	AT85 Rope	6000' 5/16" Braided Rope
P/N 9706-37414	AT85 CRR	Pilot Controller. Reel with Rope
P/N 9706-37415	AT-75WA	AT-75 Adapter, Winch Shaft with Spring

SPIDER PILOT LINE SYSTEM



The S&R Spider® System eliminates finger lines, vandalism, and extra climbs! It consists of a positive braking controller and a storage reel of rope that mount on the lead pole at any desired height. Once the controllers and storage reels are mounted on the lead pole, the lineman takes the pilot lines up with him and lays them in the stringing blocks as he frames the pole. After these lines are pulled out, they can be tied off under tension and left until time for stringing the conductor. When the pulling line is ready to be installed, the same storage reel can be mounted on either a pole-mounted winch or on a line truck winch.

S-7500 SPIDER® SYSTEM (Includes Reel With Spiderflex Rope (5/16" Diameter x 3000' Length)			
P/N 9705-14308	600080	Black Rope	(Replacement Rope Only - P/N 9704-02151)
P/N 9705-14309	600081	Green Rope	(Replacement Rope Only - P/N 9704-02150)
P/N 9706-03045	600082	Blue Rope	(Replacement Rope Only - P/N 9703-53165)
P/N 9706-03048	600083	Red Rope	(Replacement Rope Only - P/N 9704-02151)

Individual Components for S-7500 Spider® System:

P/N 9700-50838	700423	Storage Reel (Holds 3,000' of 5/16" Spiderflex Rope)
P/N 9700-50843	701134	S-75-WA Spider® Winch Shaft Adapter
P/N 9703-47081	700438	S-75-C Controller

S-8500 SPIDER® SYSTEM (Includes Reel With Spiderflex Rope (5/16" Diameter x 6000' Length)

P/N 9706-03051	600080	Black Rope	(Replacement Rope Only - P/N 9706-03073)
P/N 9706-03056	600081	Green Rope	(Replacement Rope Only - P/N 9700-55868)
P/N 9706-03055	600082	Blue Rope	(Replacement Rope Only - P/N 9700-55852)
P/N 9706-03054	600083	Red Rope	(Replacement Rope Only - P/N 9706-03075)

Individual Components of S-8500 Spider® Pilot Line System:

P/N 9703-64229	S-85-SR	Storage Reel (Holds 6,000' of 5/16" Spiderflex Rope)
P/N 9706-03069	700438	S-85-C Controller

SPIDER® TREE - CONVENIENT STORAGE

P/N 9703-64226	SST-7585	Spider® Tree (Cover not Included)
P/N 9704-85292	SST-7585	Cover for Spider® Tree



HAND TOOLS

Blanket Clamp



P/N 9701-34816



P/N 9702-97519



P/N 9703-33765

- Holds insulating blankets and cover ups securely
- Blanket pin opens to a full 5 1/2"
- Features springs for resistance, tapered ends, and molded rubber tips
- Excellent slip resistance

P/N 9701-34816 Standard Clamp

P/N 9702-97519 Clamp for use with External Rod Clampsticks

P/N 9703-33765 Blanket Clamp with Pin Boots

Ergonomic Knife



- Tempered-steel blade with the blade back ground flat for scraping copper wire
- Large finger guard helps keep fingers away from blade
- 8" in length
- Built extra strong for line work

P/N 9000-11806

Hastings Hammer Head Wrench



- The perfect tool for power linemen, telecommunications linemen, construction workers, maintenance workers
- Reduces your inventory and replacement of standard adjustable wrenches due to breakage

P/N 9700-71135 Hastings 10-312

Ideal 9-Piece Insulated Kit



Includes (1) of each of the following:

- 30-9430 9-1/4 in. Insulated Side Cutting Linesman Pliers
- 35-9029 8 in. Insulated Diagonal Cutting Pliers with Angled Head
- 35-9038 8-1/2 in. Long-Nose Pliers
- 45-9120 Insulated Premium T-Stripper
- 35-9147 Slotted 7/32 in. x 5 in. Insulated Screwdriver
- 35-9150 Insulated Screwdriver 1/4 in. x 4 in. Slotted
- 35-9151 Insulated Screwdriver 1/4 in. x 4 in. Slotted
- 35-9193 Insulated Screwdriver #1 x 3-3/16 in. Phillips
- 35-9194 Insulated Screwdriver #2 x 4 in. Phillips
- 35-9350 Tool Roll Case for 9-Piece Basic Insulated Kit

P/N 9706-40800 35-9108

Ideal 21-in-1 Twist-a-Nut™ Screwdriver



- Wire-Nut® connector wrench reduces finger fatigue and gets in tight spots
- Premium screwdriver ratchet mechanism can handle high torque without failure
- Ergonomic, slip resistant comfort grip
- Heavy-duty chrome vanadium shafts provide robust strength and long life for professional use
- Textured Santoprene™ grip provides excellent torque and resists perspiration, water, oil and chemicals
- Accu-Loop™ Wire Looping Hole
- Includes #1 Phillips, #2 Phillips, #3 Phillips, 3/16" Slot., 1/4" Slot., 5/16" Slot., #1 Square, #1 Square, #2 Square, #15 Star, #20 Star, #25 Star, #30 Star, 3/32" Hex, 1/8" Hex, 3/16" Hex, 5/32" Hex, 1/4" Nut, 5/16" Nut, 7/16" Nut

P/N 9706-40801

35-688

HAND TOOLS
SMALL HAND TOOLS

USA: 1-877-GO ALTEC
(1-877-462-5832)

www.alteccconnect.com

GREENLEE TOOL KITS

Professional Hand Tools

Designed with linemen, contractors, and cable technicians in mind, Greenlee professional hand tools are a natural extension to Greenlee's existing product lines. With a comprehensive assortment of custom-designed pliers, saws, screwdrivers, wrenches, drivers, tool bags, accessories, tool kits, and more, Greenlee hand tools meet and exceed quality expectations.



Master Electrician's Tool Kit, 28 Piece

Part Number	Greenlee	Description
9700-82087	0158-13	18" Heavy Duty Multi-Pocket Bag
9700-80799	0258-11	Heavy Duty 8 Pocket Leather Pouch
9700-81632	0358-11L	High Dexterity Gloves Size Large
9700-82092	9858-11	Heavy Duty Leather Tool Belt
9700-82054	GT-11	Voltage Tester (for kits only)
9700-80821	333A	12" Heavy Duty Hacksaw
9700-82043	1955	Pro Plus Wire Stripper 10-18 AWG
9700-82088	0153-26C	Dual NM Cable Ripper
9700-82044	1927	Stripping & Crimping Combination Tool
9700-82046	727	Cable Cutter
9700-82091	0652-11	Heavy Duty Utility Knife with Blades
9700-80731	9753-12C	Scratch Awl 3"
9700-80783	0154-10	Adjustable Wrench 10"
9700-80785	0254-11	9-Piece Folding Hex-Key Set
9700-82052	L107	Torpedo Level
9700-80797	156-11	18 oz. Electrician's Hammer
9700-82055	0153-11C	Heavy Duty Keystone Tip, Square Shank 1/4" x 4" Flat Blade Screwdriver
9700-82058	0153-15C	Heavy Duty Keystone Tip, Square Shank 5/16" x 6" Flat Blade Screwdriver
9700-82061	0153-22C	Heavy Duty Cabinet Tip, Round Shank 3/16" x 6" Flat Blade Screwdriver
9700-82068	0153-26C	Heavy Duty Cabinet Tip, Round Shank 1/4" x 6" Flat Blade Screwdriver
9700-82069	0153-31C	Heavy Duty Phillips Tip #1 - 3/16" x 3" Screwdriver
9700-82071	0153-33C	Heavy Duty Phillips Tip #2 - 1/4" x 4" Screwdriver
9700-82095	0453-14C	Screw-Holding Screwdriver 3/16" x 6"
9700-80794	0155-25	Power Return Tape Measure, Double Tang/Sided, 25'
9700-80736	0451-10M	Pump Pliers 10" Molded Grip
9700-80816	0151-09M	High Leverage Side-Cutting Pliers 9" Molded Grip
9700-81634	0251-08M	High Leverage Diagonal Cutting Pliers 8" Molded Grip
9700-80733	0351-08M	High Leverage Long Nose Pliers/Side Cutting 8" Molded Grip

P/N 9700-81673 0159-11
Complete Kit

Electrician's Tool Kit, 12 Piece



- 2" Leather Tool Belt
- 8-Pocket Leather Pouch
- 25' Tape Measure
- 9" Side-cutting Pliers
- 8" Long Nose Pliers
- 10" Pump Pliers
- 8" Diagonal Cutting Pliers
- Pro Plus Wire Stripper 10-18 AWG
- Phillips Tip #1 - 3/16" x 3" Screwdriver
- Phillips Tip #2 - 1/4" x 4" Screwdriver
- Cabinet Tip Round Shank 3/16" x 6" Flat Blade Screwdriver
- Keystone Tip Square Shank 1/4" x 4" Flat Blade Screwdriver

P/N 9700-98040 0159-13

Journeyman's Tool Kit, 17 Piece



- 20-Pocket Tool Caddy
- 25' Tape Measure
- 8" Long Nose Pliers
- 10" Pump Pliers
- NM Cable Ripper
- 9" Side-Cutting Pliers
- 8" Diagonal Cutting Pliers
- 18 oz. Electrician's Hammer
- Pro Plus Wire Stripper 10-18 AWG
- Keystone Tip Square Shank 1/4" x 4" Flat Blade Screwdriver
- Cabinet Tip Round Shank 3/16" x 3" Flat Blade Screwdriver
- GT-11 Voltage Tester, Torpedo Level
- Phillips Tip #2 - 1/4" x 4" Screwdriver
- Phillips Tip #1 - 3/16" x 3" Screwdriver
- Stripping/Crimping Combination Tool and Cable Cutter

P/N 9700-80803 0159-12

HAND TOOLS
SMALL HAND TOOLS

USA: 1-877-GO ALTEC
(1-877-462-5832)

www.alteconnect.com

GREENLEE

Hand Tools

Professional Hand Tools

HAND TOOLS
SMALL HAND TOOLS

USA: 1-877-GO ALTEC
(1-877-462-5832)

www.alteconnect.com

Heavy Duty Leather Pouches



P/N 9700-80801



P/N 9700-80800



P/N 9700-80799

For your tool storage and access needs, Greenlee has designed 3 top grain leather pouches that will not fade or stain. Featuring a minimum of four compact pockets for tool organization, tapered compartments for tool stability, a tape chain, washer rivets for extra strength, and a metal tool clip, these pouches are what every lineman needs. P/N 9700-80799 and P/N 9700-80800 feature large, divided main pockets for easy tool storage and access as well as a heavy duty tape measure holder that accepts and holds any size tape securely. Each pouch will fit belts up to 3" wide.

P/N 9700-80801 Greenlee 0258-14 4 Pocket Leather Pouch
P/N 9700-80800 Greenlee 0258-13 5 Pocket Leather Pouch
P/N 9700-80799 Greenlee 0258-11 8 Pocket Leather Pouch

13" PVC Saw



P/N 9700-17288 Greenlee 00113

- "V" tooth design enables straight cuts on both push and pull strokes
- Resharpenable blade
- Pointed blade nose makes drywall surface penetration easy
- Ergonomic handle is interchangeable with most PVC saw brands

12" Heavy Duty Hacksaw



P/N 9700-80821 Greenlee 0333-A

- Complete with bi-metal blade
- Fully adjustable blade tension up to 30,000 psi for longer blade life and faster, accurate cuts

- Overmolded rugged design
- Alternative 45° blade mounting allows for flush cutting
- Mounting for most reciprocating saw blades for extra versatility

Rothenberger Heavy Duty Pipe Wrenches



- One-handed ratchet-like use, self-clamping
- Monoblock cast body with high strength, double T profile; forged jaw and hook
- Fine polished teeth set against turning direction
- Induction hardened, tempered, and anti-slip adjustment screw
- Complies with US standard GGG-W-651 Type 1 Class A
- Quick and simple presetting

P/N 9701-55213 70152 12" 2" Max O.D.
P/N 9701-55214 70153 14" 2" Max O.D.
P/N 9701-55215 70154 18" 2 1/2" Max O.D.
P/N 9701-55216 70155 24" 3" Max O.D.
P/N 9701-55217 70156 36" 5" Max O.D.

Scissors & Knife Kit with 2-Pocket Pouch



- Tough, tempered steel knife blade holds its edge longer
- Knife has a short, coping-type blade made of the finest cutlery steel
- Full-sized knife handle provides greater comfort
- Scissors have an upper blade with two stripping notches to strip most insulations from 19-24 AWG

P/N 9000-45085 PT-K01

GREENLEE

Hand Tools

Professional Hand Tools

HAND TOOLS
SMALL HAND TOOLS

USA: 1-877-GO ALTEC
(1-877-462-5832)

www.alteconnect.com

Power Return Tape Measure



- Double sided tape with double foot can be read from above or below
- Easy to use Click Lock holds tape securely without moving the blade
- Stainless steel side panels
- Rigid 1" wide blade on all models
- Tough ABS case is over-molded with TPR for added protection
- Abrasion resistant nylon coated hardened steel blade
- Four rivets on foot resist pull-off, adjust for inside, outside readings
- 16" and 19.2" stud markings
- 0155-7MA contains a dual unit blade and metric, English units

P/N 9700-80794 Greenlee 0155-25A 25' long

P/N 9700-80795 Greenlee 0155-16A 16' long

Cushion-Grip Screwdriver Set, 5 Pc.



- Handle marked for size identification
- Precision machined black phosphate tips prevent chipping and slipping
- High grade, rust resistant, chrome finish
- 3/16" x 6" Cabinet, 1/4" x 4" Keystone, 1/4" x 6" Cabinet, 5/16" x 6" Keystone and #2 x 4" Phillips

P/N 9700-80769 Greenlee 0153-01C

Cushion-Grip Square Recess Tip Driver Set, 4 Piece



- Precision tip for accurate fastener fit
- Handle marked for easy identification
- High grade, rust resistant, chrome finish
- Contains #0, #1, #2, #3

P/N 9700-80772 Greenlee 353-01C

Folding Hex Key Set, 9 Key



- One-piece, powder-coated handle and case for corrosion resistance
- Heat-treated and tempered for extra strength and durability
- Exceeds ASME/ANSI specifications
- Including sizes 5/64", 3/32", 7/64", 1/8", 9/64", 5/32", 3/16", 7/32", 1/4"

P/N 9700-80785 Greenlee 0254-11

Ball End Folding Hex Key Set, 9 Key



- Ball-end design allows for angled use up to 30°
- Heat-treated and tempered
- Exceeds ASME/ANSI specifications
- Including sizes 5/64", 3/32", 7/64", 1/8", 9/64", 5/32", 3/16", 7/32", 1/4"

P/N 9700-80786 Greenlee 0254-12

Electrician's Hammer



- Elongated neck and narrow striking face for use in confined areas
- Long straight claws for electrical fixture removal
- Fiberglass handle for shock resistance
- Cushioned grip and flared handle end
- This is not an insulated tool

P/N 9700-80797 Greenlee 0156-11

Cushion-Grip Screwdriver Set, 7 Pc.



- Handle marked for size identification
- Precision machined black phosphate tips
- High grade, rust resistant, chrome finish
- 3/16" x 4" Cabinet, 3/16" x 6" Cabinet, 1/4" x 4" Keystone, 1/4" x 4" Cabinet, 5/16" x 6" Keystone, #1 x 3" Phillips and #2 x 4" Phillips

P/N 9700-80817 Greenlee 0153-02C

Cushion-Grip Nut Driver Set, 7 Piece



- Hollow shaft for screw clearance
- Heavy duty high grade, rust resistant, satin chrome finish
- Precision heads for accurate fastener fit
- Includes 3" shank in sizes 3/16", 1/4", 5/16", 11/32", 3/8", 7/16" and 1/2"

P/N 9700-80818 Greenlee 0253-01C

3" Scratch Awl



- Heavy duty construction for piercing and scribing
- Cushion grip for extra comfort
- Steel cap for longer life
- High grade, rust resistant, chrome-plated finish
- 7 7/8" long

P/N 9700-80731 Greenlee 9753-12C

6-in-1 Multi-Tool



- High grade, rust resistant, chrome finish
- Includes bit sizes 3/16" & 1/4" flat-tip, #1 & #2 Phillips and 5/16" & 1/4" hex
- Precision machined hardened bits
- Soft, cushioned grip for extra comfort and torque
- 7 1/8" long

P/N 9700-80820 Greenlee 0153-42C

P/N 9700-80771 Greenlee 9953-13 Replacement Bits

High Leverage Diagonal Adjustable Wrench Cutting Pliers



- Dual cutting edges for optimum performance
- Wider grip provides large load bearing area
- Effectively cuts most hardened wire, ACSR, bolts, screws, and nails
- Forged from chrome vanadium steel

P/N 9700-81634	Greenlee 0251-08M	8" Molded Grip
P/N 9700-80729	Greenlee 0251-08AM	8" Angled Molded Grip
P/N 9701-15171	Greenlee 0251-08D	8" Dipped Grip
P/N 9701-15172	Greenlee 0251-08AD	8" Angled Dipped Grip



- Patented lightweight ergonomic design
- Precision machined for smooth operation
- Wide capacity jaw provides versatility
- Exceeds ASME/ANSI specifications

P/N 9700-80775	Greenlee 0154-08C	8" Composite
P/N 9700-80777	Greenlee 0154-10C	10" Composite
P/N 9700-80781	Greenlee 0154-12C	12" Composite
P/N 9701-15176	Greenlee 0154-08D	8" Dipped Grip
P/N 9701-15177	Greenlee 0154-10D	10" Dipped Grip
P/N 9701-15178	Greenlee 0154-12D	12" Dipped Grip

High Leverage Side-Cutting Pliers



- Location of handle ridge allows user to "choke up" for greater control
- Forged from chrome vanadium steel
- Effectively cuts most hardened wire, ACSR, bolts, screws, and nails
- Diamond serrated jaws

P/N 9700-80816	Greenlee 0151-09M	9" Molded Grip
P/N 9701-15170	Greenlee 0151-09D	9" Dipped Grip

Long Nose Pliers/Side Cutters



- Flared handles for comfort and leverage
- Diamond serrated jaws and hardened cutting edges for optimum performance
- Forged from chrome vanadium steel
- Effectively cuts most hardened wire, ACSR, bolts, screws, and nails

P/N 9700-80733	0351-08M Molded Grip
P/N 9701-15173	0351-08D Dipped Grip

Adjustable Wrench



- Precision machined for smooth operation
- Wide capacity jaw provides versatility
- Corrosion-resistant finish
- Exceeds ASME/ANSI specifications

P/N 9700-80782	Greenlee 0154-08	8"
P/N 9700-80783	Greenlee 0154-10	10"
P/N 9700-80784	Greenlee 0154-12	12"

Double-Dipped Grip 16" Pump Pliers



- Double dipped grips for slip resistance
- Precision machined and through hardened for consistent performance
- Riveted process ensure joint integrity
- Right angled teeth for gripping in both directions

P/N 9700-80768	Greenlee 0451-16D
----------------	-------------------

Pump Pliers



- Precision machined and through hardened for consistent performance
- Right angled teeth for gripping in both directions
- Riveted process ensures joint integrity
- Slip-proof ergonomic grip
- User identification allowed on custom grip

P/N 9700-80736	Greenlee 0451-10M	10" Molded Grip
P/N 9700-80767	Greenlee 0451-12M	12" Molded Grip
P/N 9701-15174	Greenlee 0451-10D	10" Dipped Grip
P/N 9701-15175	Greenlee 0451-12D	12" Dipped Grip

Utility Knife



- Over-molded for secure grip
- Retractable, three position blade
- Easy front-loading design
- Pop-up holder for blade storage
- Packaged with 3 heavy duty blades

P/N 9700-80724	Greenlee 0652-11-CP	Knife w/3 blades
P/N 9700-80728	Greenlee 9952-11	5 Replacement Blades

Conduit-Reaming Screwdriver



- Deburs ID and OD of 1/2", 3/4" and 1" thin wall conduit
- Hooded, flat-tip driver used to fasten EMT fittings
- Soft, cushioned grip for extra torque
- 7 7/16" long

P/N 9700-80773	Greenlee 9753-11C	Screwdriver
P/N 9700-80774	Greenlee 9953-11	Replacement Blade

6" Keyhole Saw



- Integrated blade and handle design
- Hardened steel blade with clog-free teeth
- Pointed tip punches through drywall
- Blade cuts on both push and pull strokes
- Hole in handle may be used for lanyard or for convenient storage

P/N 9700-80730	Greenlee 301A
----------------	---------------

KLEIN TOOLS®



Committed to manufacture the highest quality hand tools with unmatched durability and comfort for over 155 years



HAND TOOLS
SMALL HAND TOOLS

SCREWDRIVERS

Cushion-Grip Screwdrivers

- Cushion-Grip screwdrivers are exceptionally strong and made of carefully heat treated and tempered steel
- The Cushion-Grip handle resists slippage which allows you to apply greater torque
- Bolster on blade at handle provides added strength and rigidity for heavy duty Cushion-Grip screwdrivers
- Blades are fully chrome-plated with black-tips
- Available with Round or Square shank
- Cushion-Grip is resistant to oil, gas, and water

11-in-1 Screwdriver/Nut Driver



- Integrated screwdriver/nut driver shaft holds 8 popular tips and converts to 3 nut driver sizes.
- Interchangeable blade for quick and easy switch out.
- Industrial strength, heat treated bits.
- Blast finish bit tips provide a firm hold and reduce cam-out.
- The following replacement bits are available: see Cat. No. 32482 (#1 Phillips & 3/16" Slotted), Cat. No. 32483 (#2 Phillips & 1/4" Slotted), Cat. No. 32484 (#1 Square & #2 Square), and Cat. No. 32485 (T10 Torx® & T15 Torx®). Assembled in USA of US and imported components. TORX® is a registered trademark of Acument Intellectual Properties, LLC.

Contains: 3/8", 5/16" and 1/4" nut drivers, #1 and #2 Phillips, 1/4" and 3/16" slotted, T10 and T15 TORX®, and #1 and #2 square recess

Cushion-Grip handle for greater torque and comfort

P/N 9701-20237 32500



P/N 9000-06004 600-4 Square-Shank Keystone-Tip; 1/4" x 4"

P/N 9000-06006 600-6 Square-Shank Keystone-Tip; 5/16" x 6"

P/N 9000-06008 600-8 Square-Shank Keystone-Tip; 3/8" x 8"

P/N 9000-06012 600-12 Square-Shank Keystone-Tip; 1/2" x 12"

Round-Shank Phillips-Tip:

P/N 9000-06034 Klein 603-4 No.2 x 4"

P/N 9000-06036 Klein 603-6 No.3 x 6"

7 Piece Cushion-Grip Screwdriver Set

- A convenient selection of popular screwdrivers including three cabinet tip, two Phillips tip and two keystone tip styles, all with Cushion-Grip high quality design and construction features
- Set is provided in recloseable seal tight vinyl pouch
- Cushion-Grip is resistant to oil, gas, and water

P/N 9000-85076 Klein 85076

DEMOLITION DRIVERS

Heat-treated shaft runs length of handle to metal strike cap



Save your other tools from the abuse these screwdrivers are designed to take. A plated metal strike cap protects the handle from hammer blows. Unique screwdriver design transfers impact force directly to the work surface. These slotted screwdrivers are available in 4" and 7" blade lengths and 1/4" and 5/16" tip sizes.

- Patented Tip-Ident® quickly identifies the type of screwdriver and screwdriver tip orientation
- Heat treated metal shaft runs complete length of handle to metal strike cap to transfer metal strike force
- Premium chrome plated for smooth feel and corrosion resistance
- Internal flanges inside handle provide solid, twist-resistant blade anchor
- Cushion-Grip handle allows for greater torque and comfort
- Meets or exceeds applicable ASME / ANSI specifications
- Special heat-treated shafts
- Precision-machined tip for exact fit

P/N 9703-77682 602-7DD 7" Demolition Driver 5/16" Keystone

USA: 1-877-GO ALTEC
(1-877-462-5832)

www.alteconnect.com

INSULATED TOOLS

Cushion-Grip Insulated Screwdriver Kit



- Individually tested to exceed standards
- Two layers of insulation provide protection against electric shock
- Highly durable, black, nylon case with custom-fitted tool pockets
- Overall case dimensions: 15-1/2" W x 11" D x 2-1/2" H

P/N 9706-37039 33528

Includes: 601-4-INS; 601-7-INS; 612-4-INS; 602-4-INS; 602-7-INS; 602-8-INS; 633-4-INS; 603-4-INS; 633-7-INS; 33538

Insulated Lineman's Skinning Knife



- Clearly marked with the official 1000-volt rating symbol

- Durable two-layer insulation
- Klein's exclusive design features molded measuring marks on back of handle to help measure stripping length of wire
- Large molded handle for an easier, more comfortable grip
- Tough, tempered steel blade provides maximum sharpness and durability to withstand frequent cable scoring
- Made in the USA
- Meets or exceeds ASTM F1505-10, IEC 60900:2012, CAN/ULC-60900-09, NFPA-70E, 2012 ed. CSA Z462-08 work

P/N 9706-40798 1571INS

Utility Insulated 13-Piece Tool Kit with Roll-Up Case



- Assortment of 13 professional, insulated tools
- Light, compact, soft roll-up carry case (with padded, adjustable carry strap) provides protective storage with custom-fitted pockets for each tool
- Kit includes a padded, adjustable shoulder strap
- Overall carrying case dimensions: Opened 24.5" x 24.5"; Closed 24.5" x 5.5"

Includes: D2000-9NE-INS; D2000-28-INS; D2000-48-INS; D203-8-INS; 602-4-INS; 602-7-INS; 602-8-INS; 633-4-INS; 603-4-INS; 633-7-INS; 63050-INS; D502-10-INS; 1571-INS; 33535SC

P/N 9706-40797 33525SC

High Leverage NE-Type INSULATED Side Cutter



- Flame retardant, impact resistant, bright orange outer coating
- Provides greater cutting and gripping power
- Smooth, streamlined nose with knurled jaws
- Rated up to 1,000 volts
- 9 1/4" length

P/N 9000-92000 D2000-9NE-INS

CUTTERS & PLIERS

Long-Nose Cutters



- Long-nose design with cutting knives
- Permits wrapping, looping, and cutting
- Plastic-dipped handles

P/N 9000-42036 D203-6
6 5/8" x 1 15/16" x 11/16" x 3/8" x 1/2" x 3/32"

P/N 9000-42037 D203-7
7 1/8" x 2 7/16" x 11/16" x 3/8" x 1/2" x 3/32"

6" Long-Nose Side Cutting Pliers



- Induction hardened cutting knives for long life
- Knurled jaws for sure wrapping and looping
- Slim head design for working in confined areas
- Hot-riveted joint ensures smooth action and no handle wobble
- Curved handles provide greater tool control
- Plastic-dipped handles for comfort and ease of identification
- Custom, US-made tool steel

P/N 9704-19684 D203-6C
6 5/8" x 1 7/8" x 11/16" x 3/8" x 1/2" x 3/32"

KLEIN TOOLS®



Committed to manufacture the highest quality hand tools with unmatched durability and comfort for over 155 years

SIDE CUTTERS & PLIERS

High Leverage NE-Type Side-Cutters

- Smooth, streamlined nose with knurled jaws
- High-leverage design
- Blue plastic-dipped handles

P/N 9000-21393 Klein D213-9NE New England Nose 9 1/4" x 1 19/32" x 1 5/16" x 5/8" x 25/32"

P/N 9000-20009 Klein D2000-9NE Heavy-Duty Cutting 2000 Series® 9 1/4" x 1 19/32" x 1 5/16" x 5/8" x 25/32"



P/N 9000-21393 P/N 9000-20009

High-Leverage Side-Cutting Pliers - Lineman's Bolt Thread Holding



- Hinge opening holds and cleans 5/8" pole line and hardware bolts or threaded rods.
- High-leverage design. Rivet is closer to the cutting edge for 46% greater cutting and gripping power than other plier designs
- Streamlined design with rounded nose and sure-gripping, cross-hatched knurled jaws
- 2000 Series - Heavy-duty cutting knives; cuts ACSR, screws, nails and most hardened wire

P/N 9000-02009 D2000-9NETH

Bolt-Thread Holding Side-Cutters



- Hinge opening holds and cleans 5/8" pole line and hardware bolts or threaded rods
- High-leverage design. Rivet is closer to the cutting edge for 46% greater cutting and gripping power than other plier designs
- Streamlined design with rounded nose and sure-gripping, cross-hatched knurled jaws
- 9 3/8" overall length

P/N 9000-02193 D213-9NETH

High-Leverage Diagonal Cutters



- High-leverage design
- Ultra-durable cutting knives
- Plastic-dipped handles

P/N 9000-20048 D2000-48
Features Angled Head
8" x 13/16" x 1 3/16" x 7/16"

High Leverage NE-Type Side-Cutters



- Smooth, streamlined nose with knurled jaws
- High-leverage design
- Blue plastic-dipped handles
- Soft, light blue handle material on outer surface for comfort and a firm grip
- Hard, black material on inner surface and handle ends for toughness and durability
- Hot-riveted joint for smooth action and no handle wobble

P/N 9000-90002 J2000-9NE 9 3/8" overall length

Pump Pliers



- Wide range of jaw opening sizes
- Jaws cannot slip under heavy pressure
- Yellow plastic-dipped handles

P/N 9000-50210 D502-10
10" long 1 3/4" jaw

P/N 9000-50212 D502-12
12" long 2 1/8" jaw

WARNING: Plastic-dipped or slip-on plastic handles are NOT intended for protection against electrical shock. This warning includes heavy-duty plastic-dipped handles. Never use any pliers or cutters on live electrical circuits.

HAND TOOLS
SMALL HAND TOOLS

USA: 1-877-GO ALTEC
(1-877-462-5832)

www.alteconnect.com

Miscellaneous

Pole Punch

- Ergonomic handle with overstrike protection
- Thermoplastic handle withstands harsh conditions and is resistant to oil and grease
- Large strike plate transfers force directly into the hardware, reducing vibration
- Chamfered tip assists centering and reduces drag

P/N 9704-46299 66326



Wrenches

4-in-1 "Bone" Wrench



P/N 9703-29889

- P/N 9703-29889 meets the ASTM standard 1000V rating
- "See-through" handle confirms metal ends are not connected
- Textured grooves in handle prevent slipping
- 1/2", 9/16", 5/8" and 3/4" sizes; 12-point sockets
- Reverse ratcheting action by reversing switches
- Made in USA
- Side 1: 5/8" & 3/4"; Side 2: 9/16" & 1/2"

P/N 9703-29889 KT223X4-INS Insulated Version

Individual Ratcheting Box Wrenches

- For use in confined spaces and on long studs
- Laminated construction for greater strength
- Ratchet is reversed by turning wrench over
- Different size openings at each end
- Available in single or double-hex
- Chrome-plated finish



P/N 9000-68202 Klein 68202 6 1/2", Single 1/2" x 9/16"

P/N 9000-68203 Klein 68203 8", Double 5/8" x 11/16"

P/N 9000-68204 Klein 68204 8", Double 5/8" x 3/4"

Compact 5-in-1 Lineman's Wrench

- Bolt-Through Design
- Reversible, Ratcheting Action
- Fits most common utility pole hardware (lag bolts, "C" clamps, and suspension bolts)
- 3/4" & 1" X 1-1/8" combo square socket for most common utility hardware
- 9/16" & 3/4" combo 12-point socket
- Made in USA

P/N 9702-32048 KT155T 9 3/8" Overall Length



P/N 9702-32048

Heavy Duty 5-in-1 Lineman's Wrench



- Bolt-through design allows bolts to pass through the socket
- 3/4" and 1" x 1-1/8" combination square socket
- Offers two popular hex sizes: 9/16" and 3/4"
- Bright yellow socket for easy visibility
- Heavy duty design

P/N 9703-29870 KT155HD

KLEIN TOOLS®



Committed to manufacture the highest quality hand tools with unmatched durability and comfort for over 155 years

HAND TOOLS
SMALL HAND TOOLS

USA: 1-877-GO ALTEC
(1-877-462-5832)

www.alteconnect.com

Wrenches



Adjustable-Head Construction Wrench

- Fits nuts and bolts to 1 1/2"
- Eliminates the need for carrying several fixed-size wrenches
- Forged from select alloy steel with continuous taper handle
- Industrial black finish for corrosion resistance
- 16" length

P/N 9700-20224 Klein 3239



1/2" Drive Ratcheting Construction Wrench

- Accepts 1/2" square-drive hex socket
- Reversible ratchet
- Eliminates the need for carrying several fixed-size wrenches
- Forged from select alloy steel
- Continuous-taper handle for aligning bolt holes
- Industrial black finish for corrosion resistance

P/N 9700-22541 Klein 3238

Klein Adjustable Wrenches



- Rail is ground for precision fit
- Chrome-plated to resist rust
- High polish chrome finish
- Heat-treated for long life
- Knurl turns smoothly for easy operation
- Contoured handles for comfortable use
- Forged heat-treated alloy steel

for maximum strength and light weight

- Extra capacity allows use of a smaller size wrench to handle bigger jobs, especially in confined spaces
- Precision-machined jaws are individually chosen and assembled by hand for smooth operation

Part Number	Klein	Description
P/N 9700-71327	507-8	8" Extra Capacity
P/N 9000-50710	507-10	10" Extra Capacity
P/N 9000-50712	507-12	12" Extra Capacity

Models Featuring Plastic Handle:

Part Number	Klein	Description
P/N 9000-50711	D507-10	10" Extra Capacity
P/N 9000-50713	D507-12	12" Extra Capacity

WARNING: Plastic-dipped or slip-on plastic handles are NOT intended for protection against electrical shock.

10" Adjustable Spud Wrench



- Versatile wrench fits nuts and bolts up to 1-5/16"
- Convenient and handy size (11" total length) with a continuous-taper handle (8") for alignment of bolt and rivet holes
- Forged from select alloy steel
- Handy lanyard hole
- Eliminates the need for carrying several fixed-size wrenches
- Made in the USA
- Heat-treated for long life
- Precision-machined jaws are individually chosen and assembled by hand for smooth operation
- Knurl turns smoothly for easy operation
- Rail is ground for precision fit

P/N 9706-40799 Klein 3227

Lineman's Standard Wrenches



- Forged from special bar steel and heat treated
- Each end has 2 different size openings
- Hole at larger end for turning in standard pole steps
- Wrench is particularly suited for use on the heavier three-bolt guy clamps on which clearance is limited
- Wrench is 13" long
- Available for 5/8" or 3/4" hardware
- Dark blue painted finish

P/N 9000-88893 3/4" Klein 3146A

17-Piece Ratcheting Box Wrench Set



- Set of the ratcheting box wrenches in heavy plastic roll-up pouch
- Both ends are offset 25° for more convenient use in confined spaces and on long studs
- Different size at each end
- Laminated construction for greater strength
- Reverse ratcheting action by simply turning wrench over
- Chrome-plated finish for rust resistance

266 P/N 9700-22542 68222

Measuring Tools

Folding Fiberglass Rule



- Positive locking joints and stainless steel spring hinges add strength
- Black markings on yellow; red stud center markings every 16"
- Measurements are marked on both sides and both edges, graduated to 1/16"
- Tough nylon reinforced with glass fibers (for added durability and resistance to weather abrasion and most chemicals)
- Engraved graduations on both sides
- Length: 6'

P/N 9700-41927 910-6 Inside Reading
P/N 9700-22314 911-6 Outside Reading

Folding Wood Rule

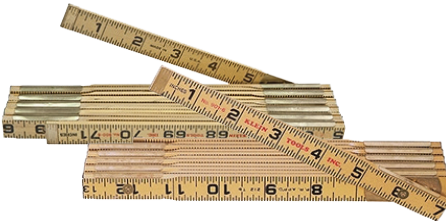

- Strong 6' long hardwood rules
- Black markings on yellow, with stud center in red
- Measurements are marked on both sides and both edges, graduated to 1/16"
- Markings are imbedded in the wood
- Tough, clear abrasion, resistant coating
- All metal parts are brass plated

P/N 9000-09006 900-6 Inside Reading
P/N 9000-00573 901-6 Outside Reading

Extension Rule



- Strong, 6' long hardwood rules with clear abrasion-resistant coating
- Black markings on yellow, with red stud center markings every 16"
- Riveted lock joints are designed for long wear and accuracy
- Engraved graduations on both sides
- Measurements are marked on both sides and both edges, graduated to 1/16th inch

P/N 9000-09056 905-6

Sockets

3-in-1 Impact Socket & Socket Adapter



P/N 9703-30033:

- Includes 3/4", 1" and 1-1/8" square sizes
- 7/16" hex quick-change adapter included
- Improved ball detent on socket adapter
- 13/16" diameter, 6" long hollow shaft for use on long threaded bolts

P/N 9703-30034:

- 7/16" hex quick-change adapter
- Improved ball detent on socket adapter

P/N 9703-30033 NRHD 13/16" Diameter
3-in-1 Impact Socket
P/N 9703-30034 NRHDA Impact Socket Adapter

3-IN-1 IMPACT SOCKET - TRANSMISSION



- Features three square socket sizes: 1-1/8, 1-5/16, and 1-1/2"
- 7/16" hex quick-change adapter included
- Fine-tuned ball detent provides improved retention, minimizing drops
- 11" length, 1" diameter, 7" long hollow shaft allows use on long, threaded bolts

P/N 9704-88104 NRHD2 **

** Adapter for 3-in-1 Impact Socket is P/N 9704-88106 NRHDA2

IMPACT SOCKET ADAPTER - TRANSMISSION

- 7/16" hex quick-change adapter included
- Fine-tuned ball detent provides improved retention, minimizing drops
- Do not exceed 200 ft. lbs.

P/N 9704-88106 NRHDA2



KLEIN TOOLS®



Committed to manufacture the highest quality hand tools with unmatched durability and comfort for over 155 years

HAND TOOLS
SMALL HAND TOOLS

USA: 1-877-GO ALTEC
(1-877-462-5832)

www.alteconnect.com

Knives

Lockback Pocket Knives



9700-99480



9701-22728



9703-30473



9700-72338

- Compact and durable, fitting comfortably in your pocket
- Opens quickly and safely with one hand via a textured thumb stud
- Corrosion resistant, premium quality AUS 8 stainless steel blades, 58-59 Rc.
- P/N 9700-99480 is also available in brushed silver (P/N 9700-96131)

P/N 9700-99480 44001-BLK 2 1/2" Drop Point Blade

P/N 9701-22728 44002 2 3/8" Drop Point Blade

P/N 9700-72338 44005 2 5/8" Sheepfoot Blade, Lightweight

P/N 9703-30473 44006 2 5/8" Sheepfoot Blade

P/N 9700-99480 44008 2 1/2" Drop Point, Screwdriver Blades

Cable-Splicer's Knife



- Special-purpose short blade with comfortable, full-sized, heavy-duty handle
- Coping-type blade made of the finest cutlery steel, tough and carefully tempered to hold its edge
- Handle is textured for comfort and firm grip
- Hang hole for easy storage and portability
- Overall length: 6 1/4"
- Blade length: 1 3/4"

P/N 9700-20869 Klein 44200

Klein Kurve® Skinning Knife



- 2" blade for increased control when scoring and slitting cable jacket
- Ergonomic handle for maximum comfort
- Oversized ring for strength and easy storage
- Notch on blade back for scraping or removing wire insulation

P/N 9706-40796 1580-3

Lineman's Knife Holder

- Leather construction
- Designed for Klein skinning knives

P/N 9000-15703

- Riveted to assure long life

P/N 9000-51630 5163



Compact Pocket Knife - 2 5/8" Stainless Steel Sheepfoot Slitting Blade



- Extra-large curved sheepfoot slitting-blade 2 5/8" long
- Ideal for heavy-duty line work
- Woodgrain plastic handle
- Blade locks open

P/N 9700-60999 1550-4 Carbon Steel

P/N 9700-59789 1550-44 Stainless Steel

Lineman's Skinning Knife



- Built extra strong for line work
- Tempered-steel blade with the blade back-ground flat for scraping copper wire
- Large finger guard helps keep fingers away from blade
- 8" in length

P/N 9000-15703 Klein 1570-3

Hacksaws



“Dual-Purpose” Hacksaw

- Powerful, efficient cutting action
- Handle design and rigid steel box frame concentrate force at the blade edge
- Easy, fingertip tensioning on all blades
- Tough, die cast aluminum handle and front end
- Excellent design for two hand sawing
- Blade cuts fully through to a flat surface; converts easily from vertical to 45° angle
- Front end holds blade for use as jab saw
- 16” length, 12” blade length
- Box frame stores extra blades
- Supplied with blade

P/N 9701-00673 701-S

High Tension Hacksaw



- Adjustable blade tension up to 30,000 PSI for fast, precise cuts
- Soft touch grips offer comfort
- Convenient blade storage in handle
- Alternative 45° mounting for flush cutting
- Front mount for reciprocating saw blades
- Includes 12” x 24 TPI bi-metal hacksaw blade and 6” x 24 TPI bi-metal reciprocating saw blade

P/N 9000-88896 702-12

Hammers

Heavy Duty Straight and Curved-Claw Hammers



Straight Claw

Curved Claw

- Durable plastic-alloy jacketing helps to protect neck from fraying and splintering if incorrectly struck or overstruck
 - High-strength fiberglass shaft absorbs shock and keeps head tight
 - Comfortable, perforated neoprene grip bonded to handle
- P/N 9000-80820 Klein 808-20 20 oz. Straight-Claw
P/N 9000-81816 Klein 818-16 16 oz. Curved-Claw

Lineman’s Hammer with Milled Face



- Designed for pole-line work
- Features a milled face on one side with a 1 3/4” round crown driving surface and smooth face on the other
- Forged, tempered-steel head is only 3 3/4” long for use in tight areas
- Rugged and well-balanced with the weight to drive lag bolts

P/N 9703-24203 809-36MF



The 1 3/4” milled face side of the hammer allows the user to drive staples straight into the pole without slipping.

While the smooth face is still important (as it should be used for hammering heavier duty hardware such as lag screws), using a smooth face for driving in staples (due to slipping potential - see staples above) can lead to staples easily being bent awkwardly while trying to hammer into the pole. Klein Tools brings the best in efficiency and quality to the worksite - and this NEW Klein Lineman hammer is no exception! Klein once again implements versatility, offering the best of both worlds in one convenient tool!



Ball-Peen Hammer

- High-carbon steel head, drop-forged and hardened
- Crowned face with uniform bevel
- Smoothly-rounded peen
- Straight-grain hickory handle, stained and lacquered

P/N 9000-80332 803-32 32 oz.

ARMSTRONG Screwdrivers are Made in the USA - Quality and Availability

- Precision Machined, Blasted Tips Provide Superior Fit Between the Tip and the Fastener Reducing Slippage and Fastener Wear
- Full Shaft Heat Treat Provides Superior Strength That Resists Tip Wear and Shank Twisting / Breakage
- Fully Polished Chrome Plated Blade Provides a High Luster That Prevents Corrosion
- Larger Than Average Handle Lengths and Diameters for Optimal Power and Comfort
- Domed Handle for Comfortably Applying Added Pressure
- Solid Impact Resistant Acetate Handle Core for Uncompromising Durability
- Cushioned Rubber Cover Preferred by Electricians for Comfort and Slippage Control



Cushion Grip, Round Shank Slotted Screwdriver

P/N 9706-37603 66-501 1/4 X 4" P/N 9706-37605 66-507 3/8 X 8"
P/N 9706-37604 66-504 5/16 X 6" P/N 9706-37606 66-510 3/8 X 12"

Cushion Grip, Round Shank Cabinet Screwdriver - 7 Pc. Set

- Includes: Round Shank-Cabinet (3/16 X 3" & 4" & 6"), -Phillips (#1 X3", #2 X 4"), Slotted 5/16 X 6", Square Shank 1/4 X 4"
- P/N 9706-37607 66-614



Electrician's, Phillips Tip, Round Shank Screwdrivers

P/N 9706-37608 66-526 #2 X 6" - Slotted
P/N 9706-37609 66-530 #3 X 6" - Slotted

ARMSTRONG 7 Pc. Ratcheting Screwdriver Set

- Made in the USA - Quality and Availability
- Smooth, Silent Clutch-Based Ratcheting Action
- In-Handle Storage for Six Bits
- Precision Machined, Blasted Tips Provide Superior Fit Between the Tip and the Fastener Reducing Slippage and Fastener Wear
- Full Shaft Heat Treat Provides Superior Strength That Resists Tip Wear and Shank Twisting / Breakage
- Fully Polished Chrome Plated Blade Provides a High Luster That Prevents Corrosion
- Larger Than Average Handle Lengths and Diameters for Optimal Power and Comfort
- Domed Handle for Comfortably Applying Added Pressure



Dual Material Phillips® Screwdriver Set:

- Includes: Phillips #1 (10-12 Slotted Bit) and Phillips #2 (5-6 Slotted Bit)
- P/N 9706-37610 66-580



CRESCENT 2000 Cushion Grip Screwdrivers

- Crescent® Series 2000 Screwdriver Set
- Set Contains 10 Popular-Sized Screwdrivers
- Available in Convenient Reusable Plastic Pouch

P/N 9706-37611 2010 Set of 10 Screwdrivers

GEARWRENCH 7 Pc. Hollow Shaft Cushion Grip Nutdriver Set - SAE



- Ergonomic Cushion Grip for Reduced Hand Fatigue and Greater Comfort
 - Includes: 3/16"-1/4"-5/16"-11/32"-3/8"-7/16"-1/2"
- P/N 9706-37612 82765 Cushion Grip, Hollow Shaft Nutdriver Set - SAE - 7 Pc. Set

GEARWRENCH 8 Pc. Ratcheting Nutdriver Set - SAE

- Precision, Fine Tooth, Reversible Ratcheting Mechanism
 - Interchangeable, Color Coded Nutdriver Shafts
 - Contoured, Dual Material Comfort Grip
 - Oil and Solvent Resistant
 - Includes: Stubby ratcheting handle, Shaft sizes 3/16-1/4-5/16-11/32-3/8-7/16-1/2"
- P/N 9706-37613 8908D 8 Pc. Ratcheting Nutdriver Set



CRESCENT Cushion Grip Tongue and Groove Pliers, Straight Jaw

- Made from finest quality alloy tool steel
- Designed to grip all shapes like rods, pipes and cable connections
- Precision-milled ribs for smooth, positive interlock between two halves
- Riveted joint will not separate or jump out of grooves
- Straight jaws and self-locking jaw adjustment
- Forged, hardened and tempered
- Red non-slip cushion handle grips
- Induction hardened angled gripping teeth
- Meets or exceeds ASME B107.23M-2004



P/N 9701-06329 R210CV 10" OAL; 1-13/16" Jaw Capacity
 P/N 9704-98457 R212CV 12" OAL; 2-1/4" Jaw Capacity
 P/N 9704-98458 R216CV 16" OAL; 4-1/2" Jaw Capacity
 P/N 9704-98459 HL120P 20" OAL; 6" Jaw Capacity

CRESCENT 8" Long Nose Pivot Pro Pliers



The NEW Crescent Pivot Pro pliers feature a unique compound action that requires 40% less effort to cut. These pliers are manufactured from forged steel for superior strength and durability. The cutting edges have been induction hardened extended life of the tool.

- Anti-rust coating
- Professional easy-clean grips
- Machined, cross checked jaw pattern for gripping and twisting
- Meets or exceeds applicable ASME performance requirements

P/N 9706-37616 CCA6548 8" Length

CRESCENT Lineman's Pliers, Side Cutting



- Designed for Electrical Work
- Electronically Induction Hardened, Durable and Keen Side Cutting Edges
- Made of Forged Alloy Tool Steel
- Polished Head
- Spring Tempered Handles with Non-Slip Cushion Handle Grips

P/N 9706-37618 507CVN 7.25" Length
 P/N 9706-37619 508CVN 8.312" Length

CRESCENT 9" Lineman's Pivot Pro Pliers



The NEW Crescent Pivot Pro pliers feature a unique compound action that requires 40% less effort to cut. These pliers are manufactured from forged steel for superior strength and durability. The cutting edges have been induction hardened extended life of the tool.

- Anti-rust coating
- Professional easy-clean grips
- Machined serrated jaws grip work tightly
- Meets or exceeds applicable ASME performance requirements

P/N 9706-37620 CCA20509

CRESCENT Diagonal Cutting Pliers, Heavy-Duty

- Designed for Heavy-Duty Wire Cutting
- Electronically Induction Hardened Hand-Honed, Long Lasting Cutting Edges
- Made of Forged Alloy Tool Steel
- Individually Tested for Strength and Cutting Ability
- Polished Head; Tapered Nose
- Red Non-Slip Cushion Handle Grips
- Angled Head for Offset Cutting
- Standard or Flush Cutting Edges

P/N 9706-37614 5428CVN 8" Length
 12 AWG Cut Capacity



CRESCENT Pivot Pro Diagonal Cutting Pliers, Heavy-Duty

The NEW Crescent Pivot Pro pliers feature a unique compound action that requires 40% less effort to cut. These pliers are manufactured from forged steel for superior strength and durability. The cutting edges have been induction hardened extended life of the tool.

- Anti-rust coating
- Professional easy-clean grips
- Designed with standard bevel edges for general wire cutting
- Meets or exceeds applicable ASME performance requirements

P/N 9706-37615 CCA5428 8" Length;
 Std./12 AWG Cut Capacity



CRESCENT 6547CVN Long Chain Nose Side Cutting Pliers

- Designed for reaching confined areas
- Long chain nose with fine serrated jaws to make wire loops and bends
- Electronically induction hardened and hand-honed, keen side cutting edges
- Polished head

P/N 9706-37617 6547CVN 7.5" Length

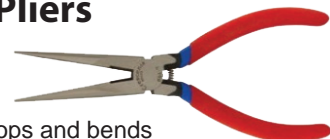

WISS Flip Joint Cable Cutters



- Designed to cut vinyl coated or bare, multi-strand copper/aluminum, up to size 10/3 cable
- Unique "Flip" design; the head flips over to be used as a cable sheath knife
- Specially designed cutting knife ensures a sharp, clean cut every time.
- 3 tools in 1: cable cutter, sheath knife, and wire stripper
- Single dipped, cushioned handles for comfort grip
- Handles flip nearly 360 degrees
- Non-insulated handles

- Smaller notches in blades for limited stripping applications and cutting smaller cable
 - Sheath Knife for slicing vinyl cable sheath
- P/N 9706-37621 0890CSFW 8" Length

271



HAND TOOLS
 SMALL HAND TOOLS

USA: 1-877-GO ALTEC
 (1-877-462-5832)

www.alteconnect.com

CRESCENT Chrome Plated Adjustable Wrenches, 1st Generation



- World famous Crescent® brand, made in the USA
- For professional, industrial or home use
- Wide capacity jaw allows each tool to work with more fastener sizes
- Wider handle provides more comfort and less stress to the hand
- Tension spring stabilizes jaw and knurl adjusts easily
- Alloy steel and heat treated
- Proportioned dimensions for greatest strength and minimum weight
- Chrome plated finish resists rust and corrosion
- Polished head and satin finished handle

P/N 9706-37622 AC18 8" OAL; 1.125" Jaw Capacity
 P/N 9706-37623 AC110 10" OAL; 1.313" Jaw Capacity
 P/N 9706-37624 AC112 12" OAL; 1.5" Jaw Capacity
 P/N 9706-37625 AC115* 15" OAL; 1.68" Jaw Capacity
 P/N 9706-37626 AC118* 18" OAL; 2.063" Jaw Capacity
 P/N 9706-37627 AC124* 24" OAL; 2.438" Jaw Capacity
 * Features Tapered Handle

CRESCENT Construction Wrench, Black Oxide Finish



- World famous Crescent® brand
- Tension spring stabilizes jaw and knurl adjusts easily
- Tapered tang for aligning bolt holes or other mating parts
- Alloy steel and heat treated for toughest jobs
- Black oxide finish resists corrosion

P/N 9706-37631 AT10SPUD 10" OAL; 1-1/8" Jaw Capacity
 P/N 9706-37632 AT115SPUD 16" OAL; 1-1/2" Jaw Capacity

ALLEN 9-Key Long Arm Metric Ball-Plus™ Magnetic Hex Key Set

- Ball-plus™ hex keys permit an entry angle up to 25° to work in hard-to-reach areas
- Magnetic head provides efficiency in holding fasteners in tight work areas
- Heat treated, tempered alloy steel provides high strength and resistance to rotational distortion
- All hex keys are precision formed to exact dimensional tolerances for precise fit
- Longer length keys for additional leverage, extended reach
- Non-interference hinged caddy provides easy access to each key



P/N 9706-37634 56600G
 Key Sizes 1.5, 2, 2.5, 3, 4, 5, 6, 8, 10

CRESCENT Oxide Cushion Grip Adjustable Wrenches, 2nd Generation



- World famous Crescent® brand
- Wider knurl for easier adjustment
- Laser etched scale provides a quick and convenient way to determine fastener size in either sae or metric
- Wide capacity jaw allows each tool to work with more fastener sizes
- Wider handle provides more comfort and less stress to the hand
- Tension spring stabilizes jaw and knurl adjusts easily
- Alloy steel and heat treated
- Proportioned dimensions for greatest strength and minimum weight
- Black oxide finish resists corrosion
- Polished head and regular handle, non-slip grip

P/N 9706-37628 AT28BK 8" Length; 1.125" Jaw Capacity
 P/N 9706-37629 AT210BK 10" Length; 1.313" Jaw Capacity
 P/N 9706-37630 AT212BK 12" Length; 1.5" Jaw Capacity

CRESCENT 3 Pc Chrome Plated Adjustable Wrench Set - 1st Generation



- World famous Crescent® brand, made in the USA
 - For professional, industrial or home use
 - Wide capacity jaw allows each tool to work with more fastener sizes
 - Wider handle provides more comfort and less stress to the hand
 - Tension spring stabilizes jaw and knurl adjusts easily
 - Alloy steel and heat treated
 - Proportioned dimensions for greatest strength and minimum weight
 - Chrome plated finish resists rust and corrosion
 - Polished head and regular, satin finished handle
- P/N 9706-37633 AC3 Set of 3 (6", 8", 10")

ALLEN 13-Key SAE Magnetic Ball-Plus™ Hex Key Set

- Ball-plus™ hex keys permit an entry angle up to 25° to work in hard-to-reach areas
- Magnetic head provides efficiency in holding fasteners in tight work areas
- Heat treated, tempered alloy steel provides high strength and resistance to rotational distortion
- All hex keys are precision formed to exact dimensional tolerances for precise fit
- Longer length keys for additional leverage, extended reach
- Non-interference hinged caddy provides easy access to each key



P/N 9706-37635 56601G
 Key Sizes 0.050, 1/16, 5/64, 3/32, 7/64, 1/8, 9/64, 5/32, 3/16, 7/32, 1/4, 5/16, 3/8

CRESCENT 12 Pc Socket Wrench Set, 1/2" Drive, SAE, 12 Point

- 1/2" Drive Ratchet handle, 72T, CRV
- 1/2" Drive 3" Extension bar, CRV
- 1/2" Drive 12 Pt. Socket, CRV: 7/16", 1/2", 9/16", 5/8", 11/16", 3/4", 13/16", 7/8", 15/16", 1"
- Storage case



P/N 9706-37636 192-CSWS11

CRESCENT 14 Pc Combination Wrench Set, 12 Pt, SAE

- Includes; 3/8", 7/16", 1/2", 9/16", 5/8", 11/16", 3/4", 13/16", 7/8", 15/16", 1", 1-1/16", 1-1/8", 1-1/4", Storage Roll



P/N 9706-37637 192-CCWS4

GEARWRENCH 8 Pc Set-Reversible Ratcheting Wrench Set

- Includes: 5/16", 3/8", 7/16", 1/2", 9/16", 5/8", 11/16", 3/4"



P/N 9706-37638 9533N

CRESCENT 148 Pc. 1/4", 3/8", and 1/2" Drive 6 and 12 Point SAE/Metric Mechanics Tool Set



- Carefully selected assortment of Crescent® brand hand tools
- Set contains all the tools needed for most industrial applications, including 1/4", 3/8", and 1/2" quick-release ratcheting drives, with a wide selection of standard and deep sockets in the most common SAE and metric sizes
- All tools in this industrial-quality tool set meet stringent new ANSI and ASME specifications and come with a full satisfaction guarantee

P/N 9706-37639 CTK148MP

CRESCENT Straight Jaw Locking Pliers



- World famous Crescent® brand
- Maximum jaw opening per ASME specs
- Angled tooth pattern for better grip
- Nickel-plated finish resists rust and corrosion
- Compound action for powerful non-slip locking grip
- Versatile curved jaw also features integral wire cutter

P/N 9706-37640 C10SV

ARMSTRONG Micrometer Torque Wrenches



- Made in the USA - quality and availability
 - Innovative linear ball bearing design mechanism for improved performance; 1) eliminates friction between spring and case for greater accuracy, 2) eliminates speed sensitivity errors, and 3) produces a "crisp audible click" over the entire range
 - Twist detent locking ring allows easy setting of desired pre-set torque and prevents accidental change of the torque setting while in use
 - Rubber seal between the ratchet head and tube keeps lubrication in and contaminants out of the torque mechanism assuring accuracy and repeatability
 - Ratchet head is specifically designed for torque wrenches with more material in high stress areas
 - Enclosed head design with 10 degree ratcheting arc seals out contaminants for improved performance and longer life
 - Torque wrap ratchet head design reduces stress on gear and pawl teeth for greater strength and durability
 - Lightly knurled and grooved handle provides a comfortable, non-slip grip
 - Accuracy; +/- 3% cw from 20% to 100% of wrench capability
 - Meets or exceeds ASME B107.14M 1994 and ISO 6789
- P/N 9706-37641 64-046 3/8" Torque Wrench 10-100 ft/lb
P/N 9706-37642 64-086 1/2" Torque Wrench 25-250 ft/lb

CRESCENT Locking Pliers Set

- World famous crescent® brand
 - Maximum jaw opening per ASME specs
 - Angled tooth pattern for better grip
 - Nickel-plated finish resists rust and corrosion
 - Compound action for powerful non-slip locking grip
 - Long nose with wire cutter gets to hard-to-reach spots
 - Versatile curved jaw also features integral wire cutter
- Includes:
- 6" long nose locking plier with wire cutter
 - 9" long nose locking plier with wire cutter
 - 7" curved jaw locking plier with wire cutter
 - 5" curved jaw locking plier with wire cutter
 - 10" curved jaw locking plier with wire cutter

P/N 9706-37643 CLP5SET

HAND TOOLS
SMALL HAND TOOLS

USA: 1-877-GO ALTEC
(1-877-462-5832)

www.alteccconnect.com

ARMSTRONG Sledge Head One-Piece Dead Blow Hammers



- Made in the USA - quality and availability
- Steel shot filled canister creates a dead blow effect; sustains impact, maximizes force, reduces / eliminates rebound, and absorbs the shock of impact
- Non-sparking hot cast urethane covers steel shot chamber and steel reinforced handle; no exposed metal
- Hot cast urethane sledge head face will not mar surfaces or absorb liquids. Resists chipping and splitting while reducing noise when striking metal objects such as slugging / striking wrenches
- Meets or exceeds US Federal Spec. GGG-H-33A

• Weighs 10.5 lbs.
P/N 9706-37644 69-552 30" Length; 8" Head Length

NICHOLSON Chain Saw Files - Round

- American pattern round chainsaw file
- Tighten tension on chain to firmly support cutters when filing
- File from inside to outside of cutter
- Place file against beveled cutting surface of teeth 20° to 45° with saw
- Follow saw manufacturers' specifications
- Sharpen all left hand cutters on one side of chain
- Then move to the other side and file all the right hand cutters
- Check depth gauge height every 2 or 3 sharpenings
- Height between cutting teeth and depth gauge is between 0.020" To 0.030"

P/N 9706-37645 02144N 6" Length, 1/8" Diameter
P/N 9703-11171 02147N 8" Length, 1/4" Diameter
P/N 9706-37646 02229B 8" Length, 3/16" Diameter
P/N 9706-37647 02228B 8" Length, 5/32" Diameter
P/N 9703-11173 02230B 8" Length, 7/32" Diameter

File Handle - Fits all Chain Saw Files Above

P/N 9706-40829 21474H



GEARWRENCH 12 pc. Punch and Chisel Set



- Chisel for cutting rivets, bolts, and nuts
- Pin punch for final removal to drive out pins and rivets
- Center punch for marking Center lines and pilot drill locations
- Long taper punch to install

and remove pins and shafts and to align holes
• Starter punch for both starting and installing pins and rivets
P/N 9706-37648 82305

Plumb Premium Ripping Claw



- High-luster, full-polished finish
 - Virtually unbreakable fiberglass handle
 - Contoured handle for increased comfort and reduced fatigue
 - Enlarged handle base for butting material
 - New grip material reduces handle slickness
 - Factory balanced for maximum striking power
 - Permabond® construction between head and handle
- P/N 9706-37649 11415N 13" Length, 16 oz.
P/N 9706-37650 11414N 13.5" Length, 22 oz.
P/N 9702-60792 11417N 15" Length, 22 oz.

NICHOLSON 9 Pc. Ergonomic File Set

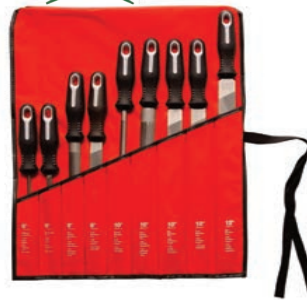

- Includes 9 tools with rubber-coated ergonomic handles for better comfort and control:
- (1) 10" Mill Bastard Cut
- (1) 6" Slim Taper File
- (1) 8" Half Round Bastard Cut
- (1) 10" Half Round Bastard Cut
- (1) 8" Flat Bastard Cut
- (1) 12" Mill Bastard Cut
- (1) 10" Flat Bastard Cut
- (1) 6" xx Slim Taper File
- (1) 10" Round Bastard File

P/N 9706-37651 22030HNN

GEARWRENCH Extendable Indexing Pry Bars



14 Locking Head Positions for Unmatched Access

Extendable handle gives greater access and leverage, and collapses so it can be stored easily



- For demolition, repositioning equipment, aligning steel components, engine repositioning, and other heavy-duty applications
- Grooved head profile provides additional traction
- Head indexible through 180° for greater leverage
- Retracts for easy storage on your truck

P/N 9706-37652 82220 18"/29" Length
P/N 9706-37653 82248 29"/48" Length

NICHOLSON 4-in-1 Pro Series Hacksaw Frame

- Standard 90 degree for general use
 - 45 degree angle for flush cuts
 - Low profile position for tight spaces
 - Jab saw configuration for a variety of inside cuts
 - High tension for tightening the blade up to 30,000 psi
 - Cushion grip handle for better control and comfort
 - Magnetic blade storage inside frame
- P/N 9706-40830 80975



NICHOLSON General Purpose Hacksaw Frame

- Instantly adjustable for 10"/250 mm to 12"/300mm blades
 - Adjusts 90° for vertical or horizontal cuts
- P/N 9706-40832 80951



NICHOLSON Double Edge Pruner

- Lightweight, economy pruner
 - Dual-purpose pruner
 - Special steel constructed blade
 - Fine teeth on one edge for light trimming
 - Teeth on opposite edge for heavier limbs
 - Wood handle
 - Plastic sleeve for blade protection
- P/N 9705-16569 80269



Lufkin® Series P1000

- Hi-viz® orange case - easy to find on the job
- Rubber cushion case exterior protects tape from impact and improves grip
- Fits easily into most tape holsters
- Bright yellow blade has clear easy-to-read numerals
- Toggle lock is positioned for convenient operation
- Holds the blade securely in any position
- Cushioned blade return

P/N 9706-40833 PHV1312 3/4" X 12' Blade Length
P/N 9704-98474 PHV1425 1" X 25' Blade Length

Lufkin® Fiberglass Tapes

- Open four-arm frame design protects blade, does not trap dirt in case
 - Lightweight but strong case is easy to handle and rewind
 - Two-material grip is comfortable to use
 - Hi-viz® orange case is easy to find on the job site
 - Folding end hook for true-zero measurements
 - Yellow clad fiberglass blade impervious to moisture
- P/N 9706-40835 FE050 1/2" x 50' Blade Length
P/N 9000-00387 FE100 1/2" x 100' Blade Length



NICHOLSON Cushion Grip Hacksaw Frame

- Rugged, lightweight frame built for professional tool users
 - High tension reading, increased blade beam strength
 - Uses high tensile strength Nicholson® Bi-Metalloy® hand hacksaw blades
 - Screw-operated lever for tensioning the blade up to 30,000 PSI
 - Blade can be positioned for 45° or 90° cutting
 - Spare blades can be stored inside frame
 - End of frame can be used as a jab saw
- P/N 9706-40831 80965



NICHOLSON Curved Pruner

- General-purpose pruner for fast cutting of small limbs
 - A favorite in citrus groves and vineyards
 - Silver Steel® constructed blade with polished finish
 - Easy-to-grip knife-type wood handle trimmed with aluminum screws
 - Full cardboard sleeve protects the blade
- P/N 9705-16567 80263



NICHOLSON Silver Flash Pruner

- Heavy-duty
 - Preferred by utility crews and tree surgeons
 - Silver Steel® constructed blade, flat ground
 - Concave cutting edge has precision set and bevel filed teeth
 - Teeth cut fast on the pull stroke
 - Extra large teeth and gullets for speed cutting large limbs
 - Wood handle
 - Full cardboard sleeve protects blade
- P/N 9705-16566 80299



Wiss® Quick-Change Folding Blade Utility Knife

- Blade safely folds into handle for compact size and easy storage
 - Quick blade change for easy and fast replacement
 - Soft grip ergonomic handle design for increased comfort
 - Accepts all standard type utility knife blades
 - Includes bonus 10 pack of blades
- P/N 9706-41341 WKF1



Lufkin® Red End® Folding Wood Rule

- Marked both sides, both edges
 - 066Fn has inside markings; numbering begins on inside of rule; measurement lies close to the work
- P/N 9706-40836 066FN 5/8" X 6' Blade Length





HAND TOOLS

THE MILWAUKEE ADVANTAGE

Nothing But HEAVY DUTY®

HAND TOOLS
SMALL HAND TOOLS

COMPACT HACK SAW

- Features a compact design that is ideal for small cutting applications
- Tool Free Blade Change - Change Blades up to 10X Faster
- Compact Design - Ideal for versatile cutting in tight spaces
- Adjustable Blade Length - Easier flush cutting
- Rubber Over Mold Grip - Increased Comfort
- Includes (1) Compact Hack Saw and (1) 10" Blade

P/N 9703-51135 48-22-0012



48-22-0012

PVC/ABS HAND SAW

- Complete with rubber-over-mold for comfort, the saw offers unmatched durability with a metal core body and clamshell handle design to prevent damage from abusive job site conditions
- Tool Free Blade Change - Change Blades up to 10X Faster
- Includes (1) PVC/ABS Hand Saw and 18" Blade

P/N 9703-51136 48-22-0223



48-22-0223

FOLDING JAB SAW

- Tool Free Blade Change - Change Blades up to 10X Faster
- Folding Blade - Easier and safer storage
- Rubber Over Mold Grip - Increased Comfort
- Accepts All Sawzall® Blades - Increased Versatility
- Uses standard Sawzall® blades and includes a metal, wood and multi purpose blade for added customer value
- Includes (1) Folding Jab Saw and (3) Reciprocating Blades

P/N 9703-51139 48-22-0305



FASTBACK™ UTILITY KNIFE

- One Handed Blade Opening - Flip Blade Open up to 3X Faster
- Tool Free Blade Change - Change Blades up to 5X Faster
- Wire Stripper - Strip up to 10 Gauge Wire
- Integrated Gut Hook - Cut Without Opening Knife
- Thin Body Design - Easy Pocket Storage
- Includes (1) Fastback™ Utility Knife and (5) Utility Blades

P/N 9702-99160 48-22-1901



SLIDING UTILITY KNIFE

- Tool Free Blade Change - Change Blades up to 5X Faster
- Side Slide Blade Activation - Less Accidental Activations
- Wire Stripper - Strip up to 10 Gauge Wire
- Blade Storage - Store up to 5 Blades
- Rubber Over Mold Grip - Increased Comfort
- Includes (1) Sliding Utility Knife and (5) Utility Blades

P/N 9702-99161 48-22-1910



FASTBACK™ HAWK BILL FOLDING KNIFE

- Press-and-flip operation: Permits one-handed opening
- Stainless steel curved blade: Resharpener edge for extended tool life
- Liner lock: Secures the blade in the open position
- Slim, compact body: Stores easily yet withstands jobsite abuse
- Piercing tip: Allows controlled piercing and smooth cutting
- Lanyard hole: Permits safe, convenient storage on a lanyard
- Reversible wire-form belt clip: Secures to your pants for quick access without damaging the fabric

P/N 9706-37281 48-22-1985



USA: 1-877-GO ALTEC
(1-877-462-5832)

www.alteconnect.com

HAND TOOLS

THE MILWAUKEE ADVANTAGE

Nothing But HEAVY DUTY®

6-IN-1 LINEMAN'S PLIERS

- Reaming Head Design-Smooth Edges of Metal Pipe From 1/2" to 1" (Patent Pending)
- Bolt Cutter-Thread and cut #6 and #8 bolts to preferred length (Patent Pending)
- Fish Tape Puller - Designed For Improved In-Line Fish Tape Pulling
- High Leverage Design - For cutting power and performance
- Laser Hardened Cutting Edges - Cuts wire, bolts, screws, and nails
- Smooth Transition Grips - Minimize wear tear and improve pouchability
- Rust Protection - Increases tool life by reducing corrosion

P/N 9703-51047 48-22-3309 9"



REAMING PLIERS

- Exposed Reaming Handles - Up to 1" Conduit (Patent Pending)
- Reaming Head Design - Smooths out rough edges of up to 1-1/2" Pipe (Patent Pending)
- Quick Adjust Jaws - V-groove jaws create a more precise fit with up to 1-1/2" Jaw Capacity
- Forged Alloy Steel - For Maximum Tool Strength
- Rust Protection - Increases tool life by reducing corrosion
- Smooth Transition Grips - Minimize wear tear and improve pouchability
- Rust Protection - Increases tool life by reducing corrosion

P/N 9703-51049 48-22-3108 8"

P/N 9703-51050 48-22-3110 10"

P/N 9703-51051 48-22-3112 12"



TONGUE & GROOVE PLIERS



- Reaming Head Design - Smooths out rough edges of up to 2" Pipe (Patent Pending)
- Forged Alloy Steel - For Maximum Tool Strength
- Induction Hardened Jaws - Long lasting toughness and consistent performance
- Smooth Transition Grips - Minimize wear tear and improve pouchability
- Rust Protection - Increases tool life by reducing corrosion

P/N 9703-51052 48-22-3210 10"

P/N 9703-51055 48-22-3212 12"

6-IN-1 LONG NOSE PLIERS

- Reaming Head Design-Smooth Edges of Metal Pipe From 1/2" to 1" (Patent Pending)
- Loop Maker - Built in loop maker for up to 10GA wire (Patent Pending)
- Wire Stripper - Strip 10-14 AWG (Solid Wire); 12-16 AWG (Stranded Wire)
- Laser Hardened Cutting Edges - Cuts wire, bolts, screws, and nails
- Rust Protection - Increases tool life by reducing corrosion
- Forged Alloy Steel - For Maximum Tool Strength
- Rust Protection - Increases tool life by reducing corrosion

P/N 9703-51058 48-22-3068

P/N 9703-51059 48-22-3069



6-IN-1 DIAGONAL PLIERS

- Reaming Head Design-Smooth Edges of Metal Pipe From 1/2" to 1" (Patent Pending)
- Bolt Cutter-Thread and cut #6 and #8 bolts to preferred length (Patent Pending)
- High Leverage Design - For cutting power and performance
- Laser Hardened Cutting Edges - Cuts wire, bolts, screws, and nails
- Offset Head Design - 15 Degree offset head for easier and quicker prying and pulling (Patent Pending)
- Rust Protection - Increases tool life by reducing corrosion

P/N 9703-51060 48-22-4106 6"

P/N 9703-51063 48-22-4107 7"

P/N 9703-51066 48-22-4108 8"



Please contact your Altec Supply Account Manager for more information regarding Milwaukee's Power Tools.



HAND TOOLS
SMALL HAND TOOLS

USA: 1-877-GO ALTEC
(1-877-462-5832)

www.alteconnect.com

TORQUE LOCK™ LOCKING PLIERS

- TORQUE LOCK™: Faster setup and easy release
- Hardened Jaws: Better grip force on jobsite material
- Forged Alloy Steel: For Maximum Tool Strength and Durability
- Rust Protection: Increases tool life by reducing corrosion
- Curved Jaw: Maximizes pressure points for any bolt, nut or locking tool application
- Straight Jaw: Maximizes contact points on jobsite work surfaces

P/N 9706-37282 48-22-3420 10"; Curved Jaw
P/N 9706-37283 48-22-3507 7"; Straight Jaw
P/N 9706-37284 48-22-3510 10"; Straight Jaw



P/N 9706-37282 48-22-3420



P/N 9706-37284 48-22-3510

8 Pc SCREWDRIVER SET



- ECX™ Bit (Patent Pending) - Superior Fit in Specialty Tools
- Wire Stripper (Patent Pending) - Strip up to 12 Gauge Wire
- Wire Bending Hole - Bend up to 12 Gauge Wire
- Shock Resistant Steel Cap
- Bits Marked on Top - Quick Identification
- Includes 8 Screwdrivers: #1 and #2 ECX™ (4") #1 and #2 Phillips (3", 4"), 1/4" and

5/16" Slotted (4", 6"), 3/16" Cabinet (3", 6")
P/N 9703-51140 48-22-2008

STILETTO 14 oz. TITANIUM HAMMER

- Milled face
- Curved handle (very lightweight)
- 45% less weight than a steel hammer
- Delivers 97% of swing energy compared to steel at 70%
- Titanium provides 10X greater dampening of harmful recoil shock (less recoil less pain)



P/N 9703-55511 TI14MC

SHOCKWAVE™ IMPACT RATED DEEP WELL SOCKETS



- Milwaukee® SHOCKWAVE Impact Duty™ Sockets are engineered for extreme durability and up to 10x life. Made from proprietary steel and heat treated to control hardness, the SHOCKWAVE Impact Duty™ Socket Adapters provide fastening capabilities with all impacts
- Chromoly steel and custom heat treatment for maximum durability in high torque applications
- Radius Corners: Drives on flats to reduce stripping and breakage
- Thin wall construction for impact strength in tight clearance applications

SHOCKWAVE™ 1/2" DEEP WELL IMPACT RATED SOCKET SET

Includes (1) 1/4" Hex to 1/2" Square Adapter AND
Includes (1) of each the following sizes of SHOCKWAVE™ Impact Sockets:

3/8" 5/8"
7/16" 11/16"
1/2" 3/4"
9/16" 7/8"

P/N 9706-37297 49-66-4484

TAPE MEASURES

- Nylon bond blade protection
- 5-Point reinforced frame
- Finger stop - protects finger during blade retraction
- Dual magnets - prevents roll off when measuring steel studs, EMT, and threaded rod
- Blueprint scale - calculates 1/4" and 1/8" drawings
- Wire form belt clip - reduces pocket tearing
- 2-Sided printing - increases measurement readability
- Up to 9' stand out
- 360 Degree hook attachment

P/N 9706-37298 48-22-5116
P/N 9705-28421 48-22-5125
P/N 9706-37299 48-22-5130
P/N 9706-37300 48-22-5135

16' Magnetic Tape Measure
25' Magnetic Tape Measure
30' Magnetic Tape Measure
35' Magnetic Tape Measure



SHOCKWAVE™ 1/2" Deep Well Socket				
Altec	Milwaukee	Drive Size	Size	Length
9706-37285	49-66-4461	1/2"	3/8"	3"
9706-37286	49-66-4462	1/2"	7/16"	3"
9706-37287	49-66-4463	3/8"	1/2"	3"
9706-37288	49-66-4464	3/8"	9/16"	3"
9706-37289	49-66-4465	3/8"	5/8"	3"
9706-37890	49-66-4466	3/8"	11/16"	3"
9706-37291	49-66-4467	3/8"	3/4"	3"
9706-37292	49-66-4468	3/8"	13/16"	3"
9706-37293	49-66-4471	3/8"	1"	3"
970637294	49-66-4472	3/8"	1-1/16"	3"
9706-37295	49-66-4473	3/8"	1-1/8"	3"
9706-37296	49-66-4475	3/8"	1-1/4"	3"



WRENCHES

NUT RUNNER - Lineman's Ratchet Wrench



- Unique bolt thru socket
- Reversible ratchet
- Heavy duty construction
- Eliminate the need to use slower open-end wrenches
- Fits nuts for both 5/8" & 3/4" machine bolts, and eliminates the need for multiple wrenches
- 3-in-1 combination includes 1/2" machine bolts
- Quick and easy to use. No more inconvenient re-positioning
- Ensures a dependable and long field life

P/N 9702-69010	GP3458	2-in-1 Combination Square Socket
P/N 9702-69014	GP345812	3-in-1 Combination Square Socket
P/N 9704-64120	LGP345812-C	3-in-1 Combination Square Socket, Compact

RATCHET FARGO® Connector Wrench

- Sturdy polypropylene handle provides protection from incidental contact
- Specially constructed for proper and fast installation of mechanical connectors
- See-through port in handle confirms that the two ends are not electrically connected

P/N 9000-22300	GP223	9/16", 3/4" ratchets
P/N 9000-22100	GP221	9/16", 3/8" ratchets
P/N 9000-02212	GP2212	9/16", 1/2" ratchets



ALLEN Ratchet Wrenches



- P/N 9000-24000 is a reversible ratchet wrench
- P/N 9000-20900, P/N 9000-02093 feature eye loops
- P/N 9000-02090 is 3/8" with a penta head
- P/N 9000-20930 is 5/16" with a 90° penta socket

P/N 9000-02090	GP2090P
P/N 9000-20930	GP2093P-90
P/N 9000-24000	GP240 5/16", 3/8" ratchets
P/N 9000-20900	GP209 3/8" ratchets
P/N 9000-02093	GP2093 5/16"

P/N 9000-24000	P/N 9000-02093	P/N 9000-20930
	P/N 9000-20900	

For additional combinations of Chance wrenches, please turn to the following page.

HAND TOOLS
SMALL HAND TOOLS

USA: 1-877-GO ALTEC
(1-877-462-5832)

www.alteconnect.com

Please contact 1-877-GO ALTEC (1-877-462-5832) for additional information regarding Chance products.

WRENCHES

HAND TOOLS
SMALL HAND TOOLS

USA: 1-877-GO ALTEC
(1-877-462-5832)

www.alteconnect.com

- Design optimized for lineman use - handle separates both ends. (GP201204 & GP216 are 1 piece style)
- Specially constructed for proper and fast installation of mechanical connectors in utility distribution applications
- Sturdy polypropylene handle provides protection from incidental end-to-end or energized line contact (all models except as noted)
- Nine available wrench heads

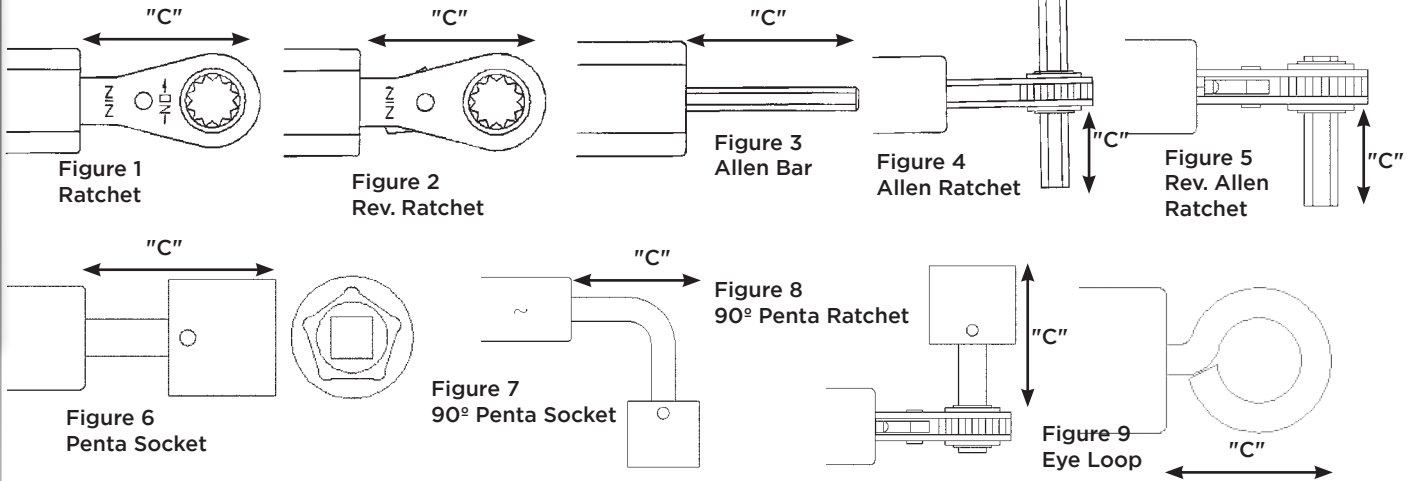

Distribution Connector Wrenches

Altec Part Number	Chance Part Number	"A" End Description	Figure	"C" Inches	"B" End Description	Figure	"C" Inches	Overall Approx. Length "L"
9702-16515	GP-201*	3/8" Ratchet	1	1-pc	9/16" Ratchet	1	1-pc	6.75"
9700-99939	GP-203*	9/16" Ratchet	1	1-pc	3/4" Ratchet	1	1-pc	6.25"
9703-66317	GP-2031*	1/2" Ratchet	1	1-pc	9/16" Ratchet	1	1-pc	6.75"
9700-70544	GP-204*	3/4" Ratchet	1	1-pc	7/8" Ratchet	1	1-pc	9.25"
9000-20900	GP-209	3/8" Allen Ratchet	4	1.21	Eye Loop	9	1.00	7.50"
9000-02090	GP-2090P	3/8" Allen Ratchet	4	1.21	Penta Socket	6	2.00	8.75"
9703-66318	GP-2090P4	3/8" Allen Ratchet	4	1.71	Penta Socket	6	2.00	8.75"
9703-66319	GP-2090P90	3/8" Allen Ratchet	4	1.21	90° Penta Socket	7	2.50	9.25"
9703-66320	GP-2091P	Penta Socket	6	1.91	Eye Loop	9	1.00	7.50"
9703-66321	GP-2091P90	90° Penta Socket	7	2.37	Eye Loop	9	1.00	8.00"
9000-02093	GP-2093	5/16" Allen Ratchet	4	1.46	Eye Loop	9	1.00	7.75"
9702-30075	GP-2093P	5/16" Allen Ratchet	4	1.46	Penta Socket	6	2.00	9.00"
9000-20930	GP-2093P90	5/16" Allen Ratchet	4	1.46	90° Penta Socket	7	2.50	9.25"
9703-66322	GP-216*	11/16" Ratchet	1	1-pc	15/16" Ratchet	1	1-pc	9.25"
9000-22100	GP-221	3/8" Ratchet	1	2.25	9/16" Ratchet	1	2.25	9.00"
9703-66323	GP-2210	3/8" Ratchet	1	2.25	7/16" Ratchet	1	2.25	9.00"
9000-02212	GP-2212	1/2" Ratchet	1	2.25	9/16" Ratchet	1	2.25	9.00"

* These wrenches do not have a polypropylene handle.

Please contact 1-877-GO ALTEC (1-877-462-5832) for additional information regarding Chance products.

WRENCHES

Ratchet Fargo Connector Wrenches

Altec Part Number	Chance Part Number	"A" End Description	Figure	"C"	"B" End Description	Figure	"C" Inches	Overall Approx. Length "L"
9703-66324	GP-2213	5/16" Ratchet	1	2.00	3/8" Ratchet	1	2.00	8.50"
9703-66325	GP-2213AR	3/8" Allen Ratchet	4	1.21	5/16" Allen Ratchet	4	1.21	9.00"
9703-66326	GP-2214	3/8" Ratchet	1	2.00	1/2" Ratchet	1	2.00	8.50"
9703-66327	GP-2215P	3/8" Reversible Ratchet	2	2.25	Penta Socket	6	2.00	8.75"
9000-22300	GP-223	9/16" Ratchet	1	2.25	3/4" Ratchet	1	2.25	9.00"
9703-66328	GP-2231	9/16" Ratchet	1	2.25	11/16" Ratchet	1	2.25	9.00"
9700-19180	GP-2232	3/4" Ratchet	1	2.25	11/16" Ratchet	1	2.25	9.00"
9000-22301	GP-2233	9/16" Ratchet	1	2.25	5/8" Ratchet	1	2.25	9.00"
9703-20939	GP-2234	1/2" Ratchet	1	2.25	5/8" Ratchet	1	2.25	9.00"
9703-66329	GP-2235	5/8" Ratchet	1	2.25	11/16" Ratchet	1	2.25	9.00"
9700-18058	GP-2236	5/8" Ratchet	1	2.25	13/16" Ratchet	1	2.75	9.50"
9700-17048	GP-2237	5/8" Ratchet	1	2.25	3/4" Ratchet	1	2.25	9.00"
9701-14963	GP-2238	3/4" Ratchet	1	2.25	13/16" Ratchet	1	2.75	9.50"
9700-75941	GP-2239	3/4" Reversible Ratchet	2	2.25	5/16" Rev. Allen Ratchet	5	1.00	9.00"
9000-02240	GP-224	3/4" Ratchet	1	2.25	7/8" Ratchet	1	2.75	9.50"
9703-66330	GP-2240	13/16" Ratchet	1	2.75	7/8" Ratchet	1	2.75	10.00"
9703-66331	GP-2241P90	13/16" Ratchet	1	2.75	90° Penta Socket	7	2.50	9.75"
9703-66332	GP-2242	11/16" Ratchet	1	2.75	15/16" Ratchet	1	2.75	9.50"
9700-18061	GP-2243	13/16" Ratchet	1	2.75	15/16" Ratchet	1	2.75	10.00"
9703-66333	GP-2245	7/8" Ratchet	1	2.75	15/16" Ratchet	1	2.75	10.00"
9703-66334	GP-239	5/16" Rev. Allen Ratchet	5	1.00	5/16" Rev. Allen Ratchet	5	1.00	9.00"
9000-24000	GP-240	5/16" Rev. Allen Ratchet	5	1.50	3/8" Rev. Allen Ratchet	5	1.38	9.00"
9703-66335	GP-240P1	3/8" Rev. Allen Ratchet	5	1.00	Penta Socket	6	2.00	8.75"
9703-66336	GP-241P	5/16" Rev. Allen Ratchet	5	1.50	Penta Socket	6	2.00	8.75"
9703-66337	GP-241P1	5/16" Rev. Allen Ratchet	5	2.00	Penta Socket	6	2.00	8.75"
9703-66338	GP-241P2	5/16" Rev. Allen Ratchet	5	1.00	Penta Socket	6	2.00	8.75"
9703-66339	GP-241P3	5/16" Rev. Allen Ratchet	5	2.50	Penta Socket	6	2.00	8.75"
9702-83351	GP-241P90	5/16" Rev. Allen Ratchet	5	1.50	90° Penta Socket	7	2.00	9.25"
9703-66340	GP-241PS-58	5/16" Rev. Allen Ratchet	5	0.63	Penta Socket	6	2.00	8.75"
9700-40180	GP-241S	5/16" Rev. Allen Ratchet	5	1.50	Eye Loop	9	1.00	7.75"
9703-66341	GP-241S3GP	3/8" Rev. Allen Ratchet	5	1.00	Eye Loop	9	1.00	9.00"
9703-66342	GP-241S-58	5/16" Rev. Allen Ratchet	5	0.63	Eye Loop	9	1.00	7.75"
9703-66343	GP-242P	5/16" Rev. Allen Ratchet	5	1.75	90° Penta Rev. Ratchet	8	2.75	9.00"
9702-84975	GP-242P-1	3/8" Rev. Allen Ratchet	5	1.38	90° Penta Rev. Ratchet	8	2.75	9.00"
9700-16829	GP-242P2	5/16" Rev. Allen Ratchet	5	2.00	90° Penta Rev. Ratchet	8	2.75	9.00"
9703-66344	GP243P	5/16" Rev. Allen Ratchet	5	1.00	90° Penta Socket	7	2.50	9.25"

HAND TOOLS
SMALL HAND TOOLS

USA: 1-877-GO ALTEC
(1-877-462-5832)

www.alteconnect.com

Please contact 1-877-GO ALTEC (1-877-462-5832)
for additional information regarding Chance products.



LOWELL CORPORATION

One wrench does the work of many!

Lineman's Triple Square Double End Wrenches

One tool works with power, cable, and telephone lines

- Five socket sizes in one wrench:
Square = 3/4" (oversize), 1", and 1-1/8"
Hex = 9/16" and 3/4" (3/4" hex also turns 5/8" square nuts)
- Two Handle Lengths - 9" and 12"
- Ergonomic handle shape makes the work more comfortable
- Reversing control at both ends
- Twice as strong as a standard ratcheting box wrench
- Flourescent orange sockets make the wrenches harder to lose, easier to find
- Bolt-thru design lets bolts pass entirely through sockets and arm head so nuts can be secured on any threaded length

P/N 9702-74857 101TDE 9" Handle
P/N 9702-74860 103TDE 12" Handle



**Five Socket Sizes
in One Wrench**



SQUARE
3/4" (oversize), 1", and 1-1/8"

HEX
9/16" and 3/4"

Triple Square Impact Socket

Use with any impact wrench to install or tighten the most popular tower hardware

DISTRIBUTION

- 6" long, 13/16" diameter hollow shaft allows use on long threaded bolts
- 7/16 Hex Quick-Change Adapter included
- Length = 7-3/4"
- Weight = 2 lbs. (with adapter)
- Square socket openings

13/16" for 1/2" hardware P/N 9703-24176 23-26908-9900 Assembly
1" for 5/8" hardware P/N 9703-24177 23-26908-9905 Socket
1-1/8" for 3/4" hardware P/N 9703-24178 23-26908-9907 Adapter

TRANSMISSION:

- 6" deep, 1-1/16" diameter hollow shaft allows use on long threaded bolts
- 7/16 Hex Quick-Change Adapter included
- Length = 10-3/8" (assembled)
- Weight = 3.5 lbs. (with adapter)
- Square socket openings

1-1/8" for 3/4" hardware P/N 9705-68588 21-T8T29-Q100 Assembly
1-5/16" for 7/8" hardware P/N 9705-68590 21-T8T29-0000 Socket
1-1/2" for 1" hardware P/N 9705-68594 21-Q1118-0000 Adapter



101 XRS Pad Mount Transformer Wrench

Designed for 5-point (security) pentagon and 3/4" hexagon hardware used in pad mount transformers, meter and valve boxes.

- Best tool to have for tight spaces and where additional clearance is required
- Reversible ratchet
- 7" handle length
- Torque tested to 90 ft-lb.'s
- "Pinned" head to eliminate plates spreading
- 32 teeth for tighter operation.
- One piece gear/shaft/socket design for strength and durability
- Vinyl grip

P/N 9705-68595 23-27810-9900



7/8" PENTAGON
3/4" HEXAGON

HAND TOOLS
SMALL HAND TOOLS

USA: 1-877-GO ALTEC
(1-877-462-5832)

www.alteconnect.com

LOWELL CORPORATION

HAND TOOLS
SMALL HAND TOOLS

USA: 1-877-GO ALTEC
(1-877-462-5832)

www.alteconnect.com

51T/151T Distribution Wrenches

- Ergonomic handle shapes
- Reversing control in head
- Enclosed ratchet mechanism on models 50T, 51T; semi-enclosed on models 101T, 150T, 151T
- Fluorescent orange sockets
- Bolt-thru design
- 100% made in USA

P/N 9000-11600 51T 51901-94800 12" Cast Handle
 P/N 9000-11610 151T 88901-94800 12" Riveted Handle
 P/N 9000-50000 50T 50901-94800 10" Cast Handle
 P/N 9000-15000 150T 88901-94800 10" Riveted Handle



101T Mini Triple Square Distribution Wrench



- Fits most common utility pole fasteners: lag bolts, C-clamps, suspension bolts
- Reduced socket depth and short handle length designed for tight spaces
- Torque capacity of 150 lb/ft.
- 100% made in USA
- 8" Length; 1.5 lbs.; 3/4" x 1" x 1-1/8"

P/N 9702-43792 101T 23075099900-23075099903

Transmission Tower Wrenches

- Bolt-Thru Design
- 100% Made in USA
- Two Square Sizes = 1-5/16" and 1-1/2"
- Provides greater flexibility for lineman dealing
- Coated with epoxy paint for durability, easy cleaning
- Designed for utility, construction, and maintenance

Double Square Impact Socket (1-5/16" and 1-1/2"):
 P/N 9000-52000 52 52901-95823 15" Cast Handle
 P/N 9000-53000 53 53901-95823 20" Cast Handle
 P/N 9000-15200 152T 15201-95823 17" Riveted Handle
Triple Square Impact Socket (1-1/8" X 1-5/16" X 1-1/2"):
 P/N 9705-68596 104T 15" Riveted Handle
 P/N 9705-68598 105T 17" Riveted Handle



Lowell Hexagonal Wrenches

- 1 1/4" hexagonal socket
- Features a reversible ratchet
- Unique "Bolt-Thru" design allows the user to tighten nuts on any threaded length
- Permanent socket will not fall off the handle

Each Feature a 1-1/4" HEX SOCKET (94720):
 P/N 9700-69027 50901-94720 10" Cast Handle (50)
 P/N 9700-72877 87901-94720 10" Riveted Handle (51)
 P/N 9700-72876 51901-94720 12" Cast Handle (150)
 P/N 9700-72878 88901-94720 12" Riveted Handle (151)



Ratcheting Lineman's Wrench Holster

- Steel Frame
- Leather back
- Accommodates all Lowell Ratcheting Lineman's Wrenches
- 2 piece screw rivet quickly attaches to any tool belt

P/N 9705-68599 21-84940-H001



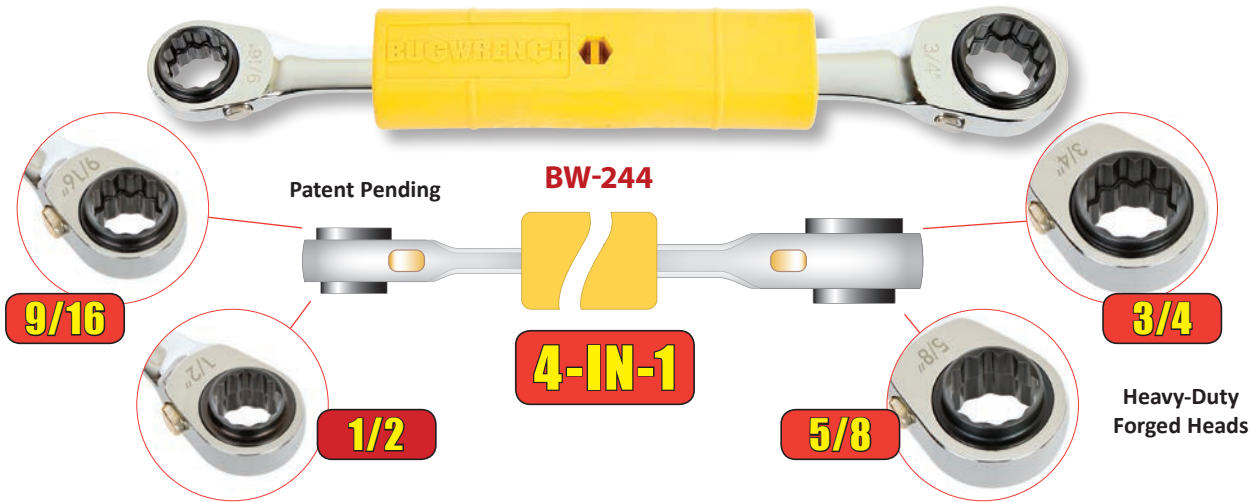

BW-244 — The New **Heavy-Duty BugWRENCH™** from Rauckman Utility Products offers a unique combination of **4-IN-1** wrenches. This reversing ratchet BUGWRENCH has two separate sizes on each end (1/2" & 9/16" on one and 5/8" & 3/4" on the other). These sizes are the most common on T&D apparatus and connectors. Model **BW-044** is all-metal 4-IN-1 wrench without insulating handle.

9703-26751

BW-244 BUGWRENCH, Reversing Ratchet, 1/2" & 9/16" - 5/8" & 3/4"

9703-26748

BW-044 BUGWRENCH, like BW-244 but All-Metal without Insulating Handle



BW-251

US Patent No. D543,810



BW-251 — This **BUGWRENCH** comes with Ratchet Penta fitting with built-in 3/8" hex socket for "Twist-Off" equipment locks and Heavy-Duty Forged 5/16" Hex (Allen) with a 2" working length for insulated or non-insulated transformer secondary bars.

9000-02510

BW-251 BUGWRENCH, Reversing Ratchet, 90° Penta - 5/16" Allen



BW-223HD

BW-223HD — This **Heavy-Duty BugWRENCH** offers 3/4" & 9/16" combination that is just right when installing or performing maintenance on overhead transformers.

9000-02230

BW-223HD BUGWRENCH, Ratchet, 3/4" - 9/16"

9000-50157

BW-203HD BUGWRENCH, Like BW-223HD but All-Metal without Insulating Handle



Ratcheting Tap and Die Tools

The RBW Tap and Die Tools have a tap and die for chasing threads on connectors and probes.

- Reversing ratchet
- Thick-walled plastic ergonomic handle (Patent: D492,556 S)

P/N 9000-50387 RBW-38TD 3/8-16 Tap And Die For Chasing Threads
On Loadbreak Elbow Probes And Connectors

P/N 9706-37332 RBW-12TD 1/2-13 Bottoming Tap And Die For Chasing Threads

P/N 9705-30305 RBW-58TD 5/8-11 Bottoming Tap And Die For Chasing Threads
On 600A Connectors

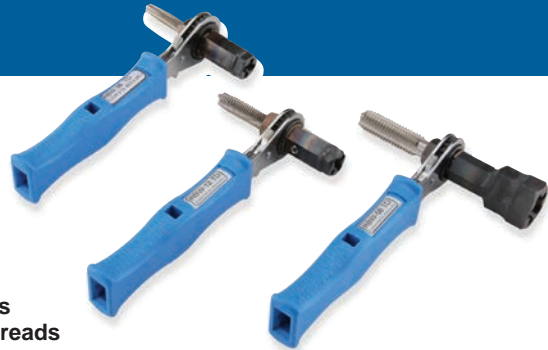

RBW-12TD Shown Left
9000-50387 Shown Middle
9705-30305 Shown Right

RBW51638SRP Ratcheting Box Wrench

5/16" hex shaft with 3/8" socket (opposed) with ratcheting Penta on other end

- Thick-walled plastic ergonomic handle with center isolation hole
- Rated 1000V
- Contact the factory for styles and configurations not shown
- Ratcheting Box Wrench (with ratcheting Penta) has 5/16" hex shaft on one side and a 3/8" socket (opposed) with ratcheting Penta on opposite end of tool

P/N 9703-68831 RBW51638SRP



Dogbone Style Ratcheting Box Wrenches Penta Socket with Ergonomic Handle



- Thick-walled plastic ergonomic handle with center isolation hole
- Rated 1000V
- Contact the factory for styles and configurations not shown.

P/N 9706-37333 RBW-12916 - 1/2" x 9/16" box wrenches
P/N 9704-26060 RBW-91634 - 9/16" x 3/4" box wrenches



- Thick-walled plastic ergonomic handle (Patent: D492,556 S)
- Standard Penta Socket

P/N 9704-90403 RBW-RP Ratcheting Penta Security Wrench

Ratcheting Box Wrench – Hex Shaft

Speed Systems RBW line includes ratcheting hex shafts for use on secondary connectors. They are available in either 5/16" or 3/8" hex stock in various lengths and configurations

P/N 9706-37334 RBW-1* 5/16" Hex shaft extended 1-1/2" on one side

P/N 9706-37335 RBW-38H* 3/8" hex shaft extended 1-1/2" on one side

* Other shaft lengths available



SC-13 Semi-Con Roller Grip



- Broad nose for rolling semi-con
- Serrated jaws for maximum grip
- Rugged plastic covered handles

P/N 9702-51763 SC-13

SC-11 Semi-Con Edge Wedge with Ergonomic Handle and Leather Sheath



- Ergonomic safety grip
- Stainless steel blade
- Comes with a molded plastic sheath

P/N 9705-30302 SC-11

Overhead Linemans Wrench

- 3/4", 1" and 1-1/8" square drive sockets on single head
- Open center for bolt to pass through
- Large reversing lever
- Padded handle
- Two-sided 3/4" and 9/16" 12 point ratcheting box wrench on opposite end
- Weighs only 1.25 lbs.!

P/N 9706-37336 OHW - Ratcheting Box Wrench for Overhead Hardware Applications

3/4", 1" and 1-1/8" square sockets with two-sided 3/4" and 9/16" ratcheting box wrench on the other end

P/N 9706-37337 OHW-D - Ratcheting Box Wrench for Overhead Hardware Applications

3/4", 1" and 1-1/8" square deep sockets with two-sided 3/4" and 9/16" ratcheting box wrench on the other end



HAND TOOLS
SMALL HAND TOOLS

USA: 1-877-GO ALTEC
(1-877-462-5832)

www.altecconnect.com

KLEIN TOOLS®



Committed to manufacture the highest quality hand tools with unmatched durability and comfort for over 155 years

HAND TOOLS
SCORERS & STRIPPERS

USA: 1-877-GO ALTEC
(1-877-462-5832)

www.alteconnect.com

Klein Automatic Wire Strippers



- For solid and stranded wire
- Strips from No. 10-22 AWG, up to a full 1"
- Plastic hand grips for comfort
- Wire is automatically gripped and stripped with the same motion
- Adjustable wire stop assures uniform, precise strip length

P/N 9700-71644 11062

Klein Multi-Purpose Electrician's Tool



- Two wire cutters - one at tip, the other halfway back near the stripping holes
- Crimps 7-8 mm insulated/non-insulated terminals, lugs, and splices
- Cuts and strips 8-22 AWG solid and 10-26 AWG stranded wire

P/N 9700-71645 1001

Klein-Kurve Wire Stripper/Cutter



- Serrated nose bends, shapes, and pulls wire
- Hardened steel with precision ground stripping holes
- Precision shear-type blades for clean cuts on stranded copper wire
- Cleanly shears 6-32 and 8-32 screws
- Strips and cuts 6-12 AWG stranded

P/N 9700-71128 11053

Klein Long Nose Multi-Purpose Tool



- Crimps insulated/non-insulated terminals and 7 to 8 mm ignition terminals
- Narrow, serrated pliers nose to pull, loop, and bend wire
- Cleanly shears bolts
- Long, curved cutting blade

P/N 9000-01010 1010

Klein Wire Stripper/Cutter



- Hardened steel; precision ground stripping holes
- Not designed for cutting steel wire or bolts
- Easy-to-read wire gauge markings on both sides
- Black-oxide finish resists corrosion
- Color-coded handles: red indicates stranded wire, yellow indicates solid wire
- Wire looping and bending holes

P/N 9700-98588	Klein 11045	10-18 AWG Solid
P/N 9700-98589	Klein 11046	16-26 AWG Stranded
P/N 9700-98590	Klein 11047	22-30 AWG Solid
P/N 9700-98592	Klein 11049	8-16 AWG Stranded

GREENLEE

SCORERS & STRIPPERS

Professional Hand Tools



Wire Strippers

- Strips insulation from most smaller gauge wire
- Strips up to 7/8" length
- Strips PVC and THHN insulation
- For use with solid and stranded wire
- Capacity: 20-10 AWG

P/N 9000-01935 1935



Greenlee Pocket Cable Strippers



P/N 9703-02574 Left
P/N 9700-98602 Right

- Easy blade depth adjustment
- 90° blade rotation allows longitudinal, circular, and spiral slitting of insulation

P/N 9703-02574 1900 Strips cables 3/16" to 1 1/8" dia.
P/N 9700-98602 1901 Strips cables 3/4" to 1 1/2" dia.

Crimping/Stripping Combination Tool

- Crimps 10-22 AWG insulated/non-insulated terminals
- Cuts #4-40, #6-32, #8-32, #10-24, #10-32 screws
- Strips 8-18 AWG solid, 10-22 AWG stranded
- Screw cutting stations are collapsed around the pivot - 20% less force is required
- Machine stripping stations feature a positive stop, providing precise stripping diameters

P/N 9700-98595 1923



Greenlee Stripping/Crimping Tool



- Machine stripping stations feature a positive stop, providing precise stripping diameters
- Crimps 10-22 AWG insulated/non-insulated terminals
- Cuts #4-40, #5-40, #6-32, #8-32, #10-24, #10-32 screws
- Strips 10-22 AWG solid and stranded
- Long, curved cutting blade reduces force required by 25% and can cut NM in a single cut
- Screw cutting stations are collapsed around the pivot - 20% less force is required

P/N 9700-82044 1927

Greenlee Wire Strippers/Cutters

- Precision ground blades ensure consistent stripping/cutting and are heat treated for long life
- Serrated nose grip for wire pulling/straightening
- Stamped from high carbon tool steel
- Pivot joints have hardened steel bushings
- Designed to cut PVC or THHN insulation

P/N 9700-98597 Greenlee 1916 20-10 AWG Solid
P/N 9700-98598 Greenlee 1917 26-16 AWG Solid
P/N 9700-98600 Greenlee 1918 30-22 AWG Solid

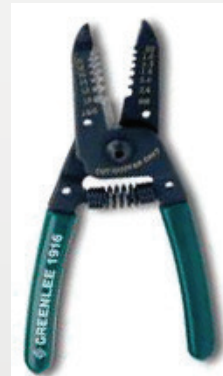

HAND TOOLS
SCORERS & STRIPPERS

USA: 1-877-GO ALTEC
(1-877-462-5832)

www.alteconnect.com

GTS 1930 SABER CABLE STRIPPER



- Reverse compatible bushing engagement
- Spring loaded retention pin
- One-way ratchet
- Grooved handle for better grip
- No-tool locking mechanism
- Laser etched depth stop

Part Number	Greenlee	Description
9706-37230	GTS-1930	Tool Only Kit (GTS 1930)
9706-37231	GTS-THHN	Bushing Kit (GTS 1930 THHN CU)
9706-37232	GTS-XHHW	Bushing Kit (GTS 1930 XHHW CU)
9706-37233	GTS-THXH	Bushing Kit (GTS 1930 TH/XH AL)
9706-37234	GTS-RH	Bushing Kit (GTS 1930 RH CU)
9706-37235	GTS-RDS	Depth Stop Replacement Kit (GTS 1930)

ALTEC	GREENLEE	THHN CU	XHHW CU	THHN/XHHN AL	RHW/RHH/ USE CU
970637236	EF-1	6	6	6	
970637237	F-1			4	
970637238	R-1				6
970637239	E-1	4	4		
970637240	EF-2	3	3	2	
970637241	R-2				4
970637242	E-2	2	2		
970637243	F-2			1	
970637244	R-3				2
970637245	EF-3	1	1	1/0	
970637246	EF-4	1/0	1/0	2/0	
970637247	R-4				1
970637248	E-3	2/0	2/0		
970637249	F-3			3/0	
970637250	R-5				1/0
970637251	E-4	3/0	3/0		
970637252	R-6				2/0
970637253	F-4			4/0	
970637254	R-7				3/0
970637255	E-5	4/0	4/0		
970637256	F-5			250 MCM	
970637257	R-8				4/0
970637258	EF-5	250 MCM	250 MCM	300 MCM	
970637259	B-1		300 MCM		
970637260	AF-1	300 MCM		350 MCM	
970637261	R-9				250 MCM
970637262	BF-1		350 MCM	400 MCM	
970637263	A-1	350 MCM			
970637264	R-10				300 MCM
970637265	E-6	400 MCM	400 MCM		
970637266	R-11				350 MCM
970637267	F-6			500 MCM	
970637268	E-7	500 MCM	500 MCM		
970637269	R-12				500 MCM
All Items Listed Below Are Not Included In Kits					
970637270	F-7			600 MCM	
970637271	E-8	600 MCM	600 MCM		
970637272	F-8			700 MCM	
970637273	F-9			750 MCM	
970637274	E-9	750 MCM	750 MCM		



QUALITY

- Replicate precise cutbacks with no additional tools
- "IT PUSHED PRODUCTION TO A WHOLE NEW LEVEL"
- "THE WORKMANSHIP WAS GRADE A QUALITY. YOU CAN'T FIND ANYTHING BETTER" *

SAFETY

- Provides a safe and quick alternative to blades*
- THE SAFETY OFFICER ON SITE SAID THAT "ONCE I SAW THE TOOL, WE DON'T SEE A NEED TO HAVE ANY BLADES ANYMORE" **

PRODUCTIVITY

- Anyone on the site can prep cables 3X faster than with a blade.
- "TURNS AN INEXPERIENCED WORKER INTO AN EXPERIENCED WORKER OVERNIGHT" *

*Starr Electric

600 VOLT SECONDARY CABLE STRIPPER



**REPLICATE EXACT CUTBACK
DEPTHS SAFER AND FASTER
THAN EVER.**

UNIVERSAL CABLE STRIPPER JRF-4

**HAND TOOLS
SCORERS & STRIPPERS**

**USA: 1-877-GO ALTEC
(1-877-462-5832)**

www.alteconnect.com



VERSATILITY

- For use with primary or secondary power cables 1/2" - 3" diameter

ERGONOMICS

- Ball bearing clamp allows for less force needed to perform strip



- 1/2" to 3" cable capacity
- Delrin™ Ball bearing rollers
- XLP and EPR Blades
- Blade depth and lock setting
- One handed tension setting
- 150 lbs of clamping force
- Roller Ball for actuation around cable
- One handed quick release trigger

- Large capacity clamp jaw – Wide range, 1/2" - 3" cable outside diameter, enabling productivity when working with a variety of cable sizes.
- Tension trigger – 150 lbs of clamping force allows user to securely capture cable for precise blade setting.
- Delrin™ ball bearing rollers – Reduces the amount of force needed for the tool to move around and up the cable during stripping.
- Rollerball actuation - Allows user to maintain constant contact with the clamp as it move around the cable.
- Precision adjustable cutting blades – EPR and XLPE design specific blades allow for ease and efficient cut back.

- P/N 9706-37275 JRF-4EPR 02746 Tool Kit, Universal Full - EPR
 P/N 9706-37276 JRF-4XLP 02747 Tool Kit, Universal Full - XLP
 P/N 9706-37277 JRF-REPR 02748 Blade Replacement Kit - EPR
 P/N 9706-37278 JRF-RXLP 02750 Blade Replacement Kit - XLP
 P/N 9706-37279 JRF-RPK 02749 Replacement Parts Kit - UNV

**QUICKLY ADJUST, SET,
AND STRIP A WIDE
VARIETY OF CABLES**

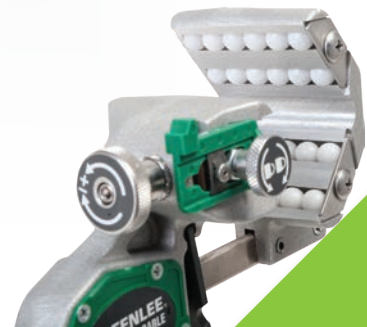

1542-2CL Series Insulation Strippers



- Cable O.D. Range 1/2" - 1-3/4"
- Strips Cable insulation
- Precise blade depth adjustment
- Maximizes reliability of installation
- Provides greater speed and increased safety
- No bushings required
- 1542 Series tools are recommended for use on the following cables:
 - KV Class / Conductor Size
 - 5kV / 1000 MCM and smaller
 - 15kV / 750 MCM and smaller
 - 25kV / 350 MCM and smaller
 - 35kV / 3/0 and smaller

P/N 9007-15422 1542-2CL Stripper
 P/N 9700-89139 1562 Replacement wedge blade
 P/N 9700-89140 1581 Replacement straight blade

Mark I Insulation Stripper

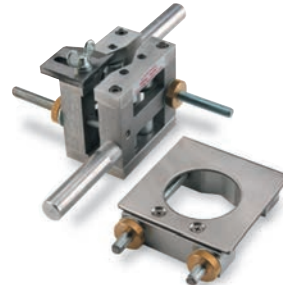

- No bushings required
- Tool Stop Accessory for Square Cut (optional)
- Heavy duty construction for optimum durability
- Heat treated rollers for ease of spiraling and reduction of cable surface friction
- Provides greater prep speed and reliability
- Holds cable securely with clamps on both sides
- Automatically walks down cable when tool is rotated

P/N 9706-37338 Mark I - with AO11 Wedge Blade
 P/N 9706-37339 Mark I Tool Stop - for Square Cut



2750 600V Secondary Insulation Stripper

- No bushings required
- End strips 600V insulation (45 mil to 110 mil thickness)
- Unlimited stripback length
- #4 thru 1000 MCM

P/N 9701-01335 2750 - Secondary Stripper
 P/N 9703-73152 2781 - Replacement Blade

2900 Aerial Tree Wire and Spacer Cable Mid-Span Stripper

- No bushings required
- Adjustable blade depth for insulation up to 300 mils (35KV)
- Reversible Positioning Jaw
- Field-replaceable blade
- Unlimited strip length

P/N 9703-80673 2900 - Stripper with Standard Handles
 P/N 9706-37340 2900S - Stripper with Short Handles



1700 Series Adjustable Blade Semi-Con Scorers

- Adjustable blade depth (.001" - .100")
- Square, and spiral cut
- Scores (scribes) semi-con without damage to insulation
- Leaf springs maintain constant pressure during operation

P/N 9701-20109 1700 Square Cut/Spiral Cut
 P/N 9007-01700 1700-SS Square Cut/Spiral Cut and Dial Locking Set Screw (shown)
 P/N 9000-70222 1700-SS-LC Square Cut/Spiral Cut and Dial Locking Set Screw - Saddle Relief for Close-in Cut

TAT/SAT Combination Splice/T-Body Tool

- Cable clamp fits #2 - 1000 MCM (0.75" - 2.42")
- Splice gripping arms open 1-1/2" - 3-3/8" (splice sleeve OD range)
- 3/4" or combination 3/8" and 3/4" hex drive
- 15" stroke (two revolutions of drive per inch of stroke)
- Ergonomically beneficial

P/N 9703-41078 TAT/SAT - Combination Splice/T-Body Tool



PRIMARY DISTRIBUTION TOOL KITS

Ripley Primary Distribution Tool Kit

A convenient way to keep all tools together for performing all tasks associated with splicing and termination. This kit is suitable for all primary needs. Please note that you must call for bushings.

P/N 9701-02621 Primary Distribution Tool Kit

- (1) P/N 9701-01200 (36312) URD Bag
- (1) P/N 9000-99562 (BP1A) Ripley Banana Peeler (.750" - 1.25")
- (1) P/N 9702-64591 (37296) WS64-U-E Adjustable Cable Stripper
- (1) P/N 9701-01186 (35150) PIT-1T Load Break Elbow Probe Insertion Tool
- (1) P/N 9701-03592 (38750) WS5A-DA Adjustable End Stripper with Chuck Adapter
- (1) P/N 9701-01185 (35900) LBIT-1T Load Break Bushing Insertion Tool



Speed Systems Combo Kit



- P/N 9007-01700 1700SS Series Semi-Con Scorer allows for square and spiral cuts, and features an adjustable blade depth of .001" - .100", Leaf springs, and a Cable O.D. Range of 1/2" - 2"
- P/N 9007-15422 1542-2CL stripper may be used on the following cables: kV Class Conductor Size, up to 5kV 1000 MCM, up to 15kV 750 MCM, up to 25kV 350 MCM, and up to 35kV 3/0; a wedge and spare straight blade are installed, and the tool features precise blade depth adjustment
- The kit also includes (1) scale gauge for measuring strip backand a 12" x 4.5" x 4" 20-gauge steel case

P/N 9700-55796 CPK-1

RIPLEY SECONDARY DISTRIBUTION TOOLS

WS 22A: Power Driven End Stripper*



- Strips quickly, even in cold climates
 - Uses standard WS 22 bushings
 - Adjustable strip stop from 1" to 4.5"
 - Guarded cutting blades ensure safety
 - Tool designed to reduce working time and effort on repetitive stripping functions
 - Precision stripping with no conductor damage
 - Choice of Drill Drive or Socket Drive adapters available
 - Ergonomic end stripping tool for 600V cables, 1/0 AWG to 1000 MCM - designed for use with low speed or variable speed power drill
- * Bushings are not included with End Strippers. Please call 1-877-GO ALTEC to order bushings.*

- P/N 9701-01191 WS 22A with 3/8" Drill Drive
 - P/N 9701-01192 WS 22A with 1/4" Hex Drive
 - P/N 9701-01196 WS 22A with 3/8" Square Socket Drive
 - P/N 9701-01197 WS 22A with 1/2" Square Socket Drive
- Bushings*

WS 68 SNAP: Power Driven End Stripper*



- Guarded cutting blades ensure safety
 - Strips quickly, even in cold climates
 - 3/8" & 1/2" square socket adapters available
 - Precision stripping with no conductor damage
 - Designed for low speed or variable speed drills
 - Features a bushing quick disconnect feature eliminating the need for a hex wrench
 - Ergonomic end stripping tools for 600 volt secondary cable; designed for use with a low or variable speed power drill
 - New adjustable strip stop with adjustment window allows easy setup for precise strip lengths from 0.625" to 2.5"
- Uses standard 2 x 2 and 4 x 4 bushings: #6 AWG to 500 MCM (concentric, compressed, or compacted)
 - Available with choice of drill drive or socket drive adapter

P/N 9700-89411 WS 68 SNAP
Bushings*

HAND TOOLS
SCORERS & STRIPPERS

USA: 1-877-GO ALTEC
(1-877-462-5832)

www.alteconnect.com

RIPLEY SECONDARY DISTRIBUTION TOOLS

WS 22: Double Ended End Stripper*



- Precision stripping with no conductor damage
- For 600 volt cables, 1/0 AWG to 1000 MCM
- Square-cuts two specific cable sizes
- Stripping length preset at factory, special order
- Ergonomic end stripping tools for up to 600V secondary cable

P/N 9701-01190 WS 22
Bushings*

* Bushings are not included with End Strippers.
Please call 1-877-GO ALTEC to order bushings.

WS 68: Power Driven End Stripper*



- Ergonomic end stripping tools for 600V secondary cable
- Designed for use with a low or variable speed power drill
- New adjustable strip stop with adjustment window allows easy setup for precise strip lengths from 0.625" to 2.5"
- Uses standard 2 x 2 and 4 x 4 bushings: From #6 AWG to 500 MCM (concentric, compressed, or compacted)
- Plugs into chuck endings of cordless drills

P/N 9700-60374 WS 68 (37430)
Bushings*

SCORERS & STRIPPERS

Ripley PIT-1T Load Break Elbow Probe Insertion Tool



- For insertion of probe into 15 to 34.5 kV elbow - small interface
- Multiple drive system; 125 in-lb. torque
- Prevents load break probe breakage and contamination; reduces cross threading
- Adjustable and removable "T" handle
- 1" steel drive and adjustable wrench
- 3/8" square drive socket

P/N 9701-01186 35150

Ripley WS 5A: Adjustable End Stripper



- Adjustable strip stop with rotary mechanism
- Adjustment window allows easy setting of stop
- Strip lengths from 0.625" up to 2.5"
- Ideal for primary URD cable
- For 600 volt to 35 kV cables, 0.260" to 1.265" Cable O.D.
- Strips XLPE, polyethylene, EPR insulation up to 400 mils thick (insulation only or with semicon over insulation)

P/N 9000-37415 WS-5A End Stripper*
P/N 9701-03592 WS 5A-DA End Stripper w/ Chuck Adapter*
P/N 9700-89541 CB 7-2 Replacement Blade

* Bushings are not included with End Strippers. Please call 1-877-GO ALTEC (1-877-462-5832) to order bushings.

Ripley LBIT-1T Load Break Bushing Insertion Tool



- For 200 amp bushing inserts with internal hexagon socket drive
- Multiple drive system; preset 180 in-lb. torque rating
- Adjustable "T" handle; standard penta head
- 7/8" hexagon for wrench
- 1" square drive socket

P/N 9701-01185 35900

Ripley WS 64-U-E Adjustable Cable Stripper



- Universal tool for end stripping outer jackets up to 2.5" O.D. or insulation up to 1.5" O.D. with interchangeable blades
- 'Dual position' jaw for cable sizes from 1/2" to 2 1/2"
- Spring loaded 'trigger-action' jaw
- Micro-adjustable blade and self feeding tool

P/N 9702-64591 37296

SCORERS & STRIPPERS

Ripley WS70 Wire End Stripper



- 1.0" to 3.65" O.D. cable range
- Self-feeding during stripping operation
- Fine adjustment feature on the blade
- Dual handle design gives greater leverage
- Blades can be replaced
- Strips out jacket or insulating material on 46 to 69kV cable

P/N 9000-00537 700FP

Ripley 2 x 2 & 4 x 4 Plus Tool



- For 600 volt secondary cable
- Strips quickly, even in cold climates
- Guarded blades ensure safety
- Bushings change easily
- Precision stripping
- Strips 45 - 110 mil secondary insulations

P/N 9007-36001 4 x 4 Plus Tool*
P/N 9700-52003 2 x 2 Plus Tool*

*Bushings are included. Specify cable sizes to order bushings
Please call 1-877-GO ALTEC (1-877-462-5832) to order.

Speed Systems 1542-2CL Stripper



- Use on the following cables: kV Class Conductor Size, up to 5kV 1000 MCM, up to 15kV 750 MCM, up to 25kV 350 MCM, and up to 35kV 3/0
- Wedge and spare straight blade installed
- Precise blade depth adjustment
- No bushings required

P/N 9007-15422 1542-2CL Stripper
P/N 9700-89139 1562 Replacement wedge blade
P/N 9700-89140 1581 Replacement straight blade

Ripley Banana Peeler



- Adjustable blade semi-con scoring tool
- Scoring depth from 1 to 90 mils
- Length: 9.4"
- Weight: 13 oz.

P/N 9000-99561	35250	.375" - .750"
P/N 9000-99562	BP1A	.750" - 1.25"
P/N 9000-99563	BP2A	1.25" - 2.00"
P/N 9701-27533	BP3A	
P/N 9000-99564	34230	Replacement blade

Speed Systems Semi-Con Scorer



- Adjustable blade depth (.001" - .100")
- Allows for square and spiral cuts
- P/N 9007-01700 features leaf springs and Cable O.D. Range 1/2" - 2"
- P/N 9700-57167 features coil springs and Cable O.D. Range 1 3/4" - 3"

P/N 9007-01700 1700SS
P/N 9700-57167 1800SS
P/N 9700-89137 1678 Scoring Blade Only

2750 Secondary End Strip Stripper



- Cable O.D. .31" - 1.375"
- No bushings are required
- End strips 600V cable or insulation (45 mil to 110 mil thickness)
- Unlimited stripback length
- #4 thru 1000 MCM

P/N 9701-01335 2750 Secondary Stripper

HAND TOOLS
SCORERS & STRIPPERS

USA: 1-877-GO ALTEC
(1-877-462-5832)

www.alteconnect.com

GREENLEE MANUAL CUTTERS & CRIMPERS

Compact Ratchet Cable Cutters



- Simple, one-hand operation
- Compact – convenient for working in tight places and stores easily in tool pouches
- Single-speed ratchet mechanism
- Blade release allows blades to be opened in mid-cut
- Heavy-duty blades provide long life

P/N 9700-39918 (759)	Copper	Aluminum	Communications Cable
Maximum Capacity*	500 kcmil (MCM)	750 kcmil (MCM)	1 1/8" diameter
Frequent Use Capacity*	400 kcmil (MCM)	600 kcmil (MCM)	
Length	10 1/2"		
Weight	1.4 lbs.		
P/N 9701-80889 (760)	Copper	Aluminum	Communications Cable
Maximum Capacity*	1000 kcmil (MCM)	1000 kcmil (MCM)	1 3/4" diameter
Frequent Use Capacity*	750 kcmil (MCM)	1000 kcmil (MCM)	
Length	11 3/4"		
Weight	1.75 lbs.		

Heavy Duty Cable Cutters

718F, 704, 705 and 706:

- Strong, lightweight fiberglass handles
 - Adjustable pivot bolt provides for blade adjustment
- 704, 705 and 706:
- Replaceable, forged, heat-treated, and precision ground blades
 - Made in USA



Capacities*	P/N 9000-10507 718F	P/N 9000-24564 704	P/N 9000-05923 705	P/N 9000-00706 706
Copper				
Maximum Use	350 kcmil (MCM)	350 kcmil (MCM)	500 kcmil (MCM)	750 kcmil (MCM)
Frequent Use	4/0 AWG (95)	250 kcmil (MCM)	350 kcmil (MCM)	500 kcmil (MCM)
Aluminum				
Maximum Use		500 kcmil (MCM)	1000 kcmil (MCM)	1000 kcmil (MCM)
Frequent Use	350 kcmil (MCM)	350 kcmil (MCM)	750 kcmil (MCM)	750 kcmil (MCM)
Communications Cable				
Maximum Use	1" diameter	1 1/4" diameter	1 3/4" diameter	1 1/2" diameter
Frequent Use				
Length	17-1/2"	21"	25-1/2"	31-1/2"
Weight	2.8 lbs.	3.01 lbs.	5.5 lbs.	6.2 lbs.

*Capacity may be less for compact and compressed cables

Cable Cutter



P/N 9700-82046 (727)

- Easily cuts heavier copper and aluminum cables up to 2/0
- Precision-ground, shear-action, curved cutting blades
- P/N 9700-82046 (727) has PVC-covered, high-leverage handles for easier cuts
- P/N 9701-36930 (727M) has cushion grip, high-leverage handles for added comfort
- Heat-treated for long life
- Made of heavy-duty forged steel
- Rust-resistant black oxide finish

P/N 9700-82046 (727)	Copper	Aluminum	Communications Cable
Maximum Capacity	2/0		
Frequent Use Capacity	#1 AWG	2/0	100 pair
Length	9 1/4" long		
Weight	1 lb.		



P/N 9701-36930 (727M)

USA: 1-877-GO ALTEC
(1-877-462-5832)

www.alteconnect.com

GREENLEE MANUAL CUTTERS & CRIMPERS

Professional Tools

HAND TOOLS
MANUAL CUTTERS & CRIMPERS

Heavy Duty Ratchet Cable Cutters

- Extra thick blades, ground flat to reduce potential for breakage
- Ratchet action for heavy-duty cutting
- Two cutting actions – fast scissor cutting for small cable and insulation; converts automatically to ratchet mode
- Anti-slip mechanism for positive ratchet action.
- Rubber boot protects ratchet mechanism
- NOT for ACSR

P/N 9000-00756 (756)	Copper	Aluminum
Maximum Capacity	1500 kcmil (MCM)	1500 kcmil (MCM)
Frequent Use Capacity	1000 kcmil (MCM)	1000 kcmil (MCM)
Length 27-1/2" long		
Jaw opening 2"		
Weight 11.41 lbs.		



Two-hand Ratchet Cable Cutter

- Two-handed operation provides more leverage and makes cutting large cables easier
- Short fiberglass handles make it easy to use in tight places and to store in tool boxes
- Blade release allows blades to be opened in mid-cut
- Single speed ratchet mechanism
- Heavy duty forged steel blades provide long life

P/N 9700-39919 (761)	Copper	Aluminum	Communications Cable
Cutting Capacity	1000 kcmil (MCM)	1000 kcmil (MCM)	1 1/8" diameter
Length 10 3/4" long			
Weight 3.6 lbs.			



High Performance Cable Cutters

- Two-speed mechanism saves cutting time by closing the blades rapidly and shifting to normal speed to perform the cut
- No more pushing on stubborn release buttons—the blades open automatically when the cut is complete
- Completely new ratchet mechanism improves durability.
- Narrow profile permits use in deep boxes, against walls or on floors.
- Durable, lightweight fiberglass handles.
- U.S. Patent #6,766,581

P/N 9000-00773 (773)	Copper	Aluminum	Communications Cable
Maximum Capacity*	500 kcmil (MCM)	795 kcmil (MCM)	1 3/16" diameter
Frequent Use Capacity*	350 kcmil (MCM)	750 kcmil (MCM)	
Length 15-1/2"			
Weight 5.3 lbs.			

P/N 9000-00774 (774)	Copper	Aluminum	Communications Cable
Maximum Capacity*	750 kcmil (MCM)	795 kcmil (MCM)	1 3/16" diameter
Frequent Use Capacity*	500 kcmil (MCM)	750 kcmil (MCM)	
Length 19-1/28"			
Weight 5.38 lbs.			



Performance Ratchet Cable Cutters

- Simple, one-hand operation
- Exclusive two-speed ratcheting mechanism adjusts for light/heavy cutting
- Well-suited for tight working spaces
- Blades can be opened mid-cycle
- Available with cushioned handles or with 1000V insulated cushioned handles

P/N 9000-45206 (45206)	Copper	Aluminum	Communications Cable
Maximum Capacity*	600 kcmil (MCM)	600 kcmil (MCM)	1 3/18" diameter
Frequent Use Capacity*	500 kcmil (MCM)	500 kcmil (MCM)	
Length 11"			
Jaw opening 1-7/16"			

P/N 9000-45207 (45207)	Copper	Aluminum	Communications Cable
Maximum Capacity*	750 kcmil (MCM)	1000 kcmil (MCM)	2" diameter
Frequent Use Capacity*	600 kcmil (MCM)	750 kcmil (MCM)	
Length 11"			
Jaw opening 2"			



USA: 1-877-GO ALTEC
(1-877-462-5832)

www.alteconnect.com



Hydraulic ACSR Cable Cutter

- Hydraulic cutter takes the effort out of cutting tough cables
- Flip-open head provides strength while making it easy to cut long lengths
- Head rotates 180°
- Thumb release lever for quick blade retraction

P/N 9700-12892 Greenlee HK520
Capacity: ACSR: 336.4 kcmil (MCM)
 Standard Guy Wire, Ground Rod: 1/2" (13 mm)
 Soft Steel Bolts: 11/16" (17 mm)
 Wire Rope: 3/4" (19 mm)
 Rebar: 7/16" dia. (Schedule 60)
 Length 14.5" (368 mm)
 Weight 5.7 lbs. (2.6 kg)

High Performance Ratchet ACSR Cable Cutter

- Two-speed mechanism saves cutting time by closing the blades rapidly and shifting to normal speed to perform the cut
- Patented mechanism opens the blades automatically when the cut is complete (U.S. Patent #6,766,581)
- Completely new ratchet mechanism provides excellent durability.
- Short length fits easily into truck bins.
- Durable, lightweight fiberglass handles.

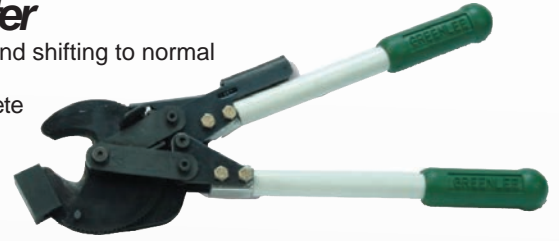

P/N 9000-00394 Greenlee 776

Capacity Cuts ACSR through 636 kcmil with steel core diameters less than 0.32"
Specifically Cuts: All 336.4 and Smaller ACSR plus:
 397.5 - Brant, Chickadee, Ibis; 477.0 - Pelican, Flicker, Hawk; 556.5 - Osprey, Parakeet
 605.0 - Peacock; 636.0 - Kingbird, Swift, Rook

Length 20"
Weight 6.2 lb.

Ratchet ACSR Cable Cutter

- Extra-thick blades, ground flat to reduce potential for breakage.
- Ratchet action for increased cutting power.
- Two cutting actions – fast scissor cutting for small cable; converts automatically to ratchet mode
- Anti-slip mechanism for positive ratchet action.
- Rubber boot protects ratchet mechanism.

P/N 9700-12948 Greenlee 757

Capacity 954 kcmil (MCM) ACSR, 1/2" soft steel rod
Length 29-1/4"
Jaw opening 1.18"
Weight 12.22 lbs.



Heavy-Duty Ratchet Guy Wire Cutter



- Cuts 1/2" Extra High Strength (EHS) and standard guy wire.
- Cuts 1/2" (12.7 mm) mild steel rods and bolts.
- Two cutting actions – single-motion cutting for small cable, ratchet action for heavy-duty cutting
- Anti-slip mechanism for positive ratchet action
- Suitable for cutting ACSR

P/N 9000-00758 Greenlee 758

Capacity 1/2" EHS and standard Guy Wire, 1/2" Mild Steel Rods and Bolts
Length 27-3/4"
Weight 10 lbs. 12 oz.

GREENLEE MANUAL CUTTERS & CRIMPERS

ACSR Cable Cutter

- Precision-machined, forged steel blades.
- Cuts ACSR service entrance cable.
- Steel handles with rubber hand grips.

P/N 9702-16516 749

SPECIFICATIONS:

Capacity ACSR Cable: 2/0, 7/16"

Piano Wire: 1/8"

Copper/Aluminum Cable: 350 kcmil (mcm)

Length 28"

Weight 5.66 lbs.



Telco Ratchet Cable Cutters



- This versatile cutter has a specially designed moving blade to handle the larger diameter telephone cable and soft drawn copper and aluminum
- Cuts up to 2,700 pair 3" telephone cable
- Blade release for safety and fast backout
- Ratchet lock
- Blades are manufactured from high carbon tool steel and heat-treated for long life
- Rust-resistant, black oxide finish
- Does NOT cut ACSR
- Length 11 1/2"
- Weight 2.8 lbs.

P/N 9000-45240

45240

Heavy Duty Manual Communications Cable Cutter

- Forged and heat-treated blades specially designed for communications cable
- Easily cuts cables up to 2 1/4" in diameter
- Makes clean cuts with minimal distortion on lead, rubber PVC and polyethylene-sheathed cables
- Blades and handles are replaceable in case of damage
- Precision-ground, shear-type blades
- Fiberglass handles with non-slip rubber grips

P/N 9000-00427 Greenlee 765

Cutting Capacity 2-1/4"

Communications Cable (900 pair, 24 AWG)

Length 37"

Weight 7.2 lbs.



ROCUT® Professional 75TC Plastic Pipe Shears



- Precise cutting of PVC, PP, PE, PEX, PB, and PVDF up to 3" diameter
- Double-sided blade and ratchet support
- Precise force transfer and guided cutter feed
- Stainless steel blade

P/N 9700-71888 52015

MANUAL CUTTERS & CRIMPERS
HAND TOOLS

USA: 1-877-GO ALTEC
(1-877-462-5832)

www.alteconnect.com



P/N 9700-39916



P/N 9700-39915

12 Ton Hydraulic Crimping Tools

- Two crimping head choices: HK1230 with 1.20" opening, and HK1240 with 1.65" opening
- Accept Greenlee KC12, KA12 and KD12 crimping dies as well as industry "U" style dies
- Tested to 50,000 crimp cycles
- Two-speed pump to reduce cycle time
- Ram automatically retracts when crimp cycle is complete - a Greenlee exclusive
- Crimping heads rotate 360°
- Smaller and lighter than competitive tools
- Covered head models have two layers of PVC that total approximately 3/16" (4.8 mm) thick; The outer layer is black and the inner layer is red
- Includes carrying case.
- U.S. Patent #6,206,663.

Capacity*:
8 AWG to 750 kcmil copper color-coded lugs and splices
Crimping Force 24,000 lbs

Lengths:	Weight:
HK1230 – 20-3/8"	HK1230 – 12.2 lbs.
HK1240 – 21-1/2"	HK1240 – 13.2 lbs.

	Greenlee	Length	Jaw Opening
P/N 9700-39916	HK1230	20 3/8"	1.2"
P/N 9700-39915	HK1240	21 1/2"	1.65"

*HK1230 and HK1240 are UL and cUL classified with Anderson, Blackburn, FCI Burndy, ILSCO, Panduit, Penn-Union and Thomas & Betts copper and aluminum color-coded lugs and splices when used with Greenlee KC12 and KA12 crimping dies. The products listed above are registered trademarks of Anderson®, Blackburn®, FCI Burndy®, ILSCO®, Panduit®, Penn-Union® and Thomas & Betts®.

12-Ton Manual Hydraulic Crimping Tool



- Two-speed ram advances fast and shifts to lower speed to complete the crimp
- Strong, lightweight fiberglass handles
- Push button permits dies to be inserted and removed easily
- The "C" style head has a 1.4" (32 mm) opening for easy placement on connectors
- Tool is supplied in a durable, molded plastic carrying case
- Accepts Greenlee KC12, KA12 and KD12 as well as Industry "U" style dies

P/N 9000-00176 Greenlee HKL1232
Capacity* 8 AWG to 750 kcmil copper color-coded lugs and splices
Crimping Force 24,000 lbs.
Length 24 1/4"

*UL and cUL is classified with Anderson, Blackburn, FCI Burndy, ILSCO, Panduit, Penn-Union and Thomas & Betts copper and aluminum color-coded lugs and splices when used with Greenlee KC12 and KA12 crimping dies. The products listed above are registered trademarks of Anderson®, Blackburn®, FCI Burndy®, ILSCO®, Panduit®, Penn-Union® and Thomas & Betts®.

K4250 & K425BG Crimping Tools

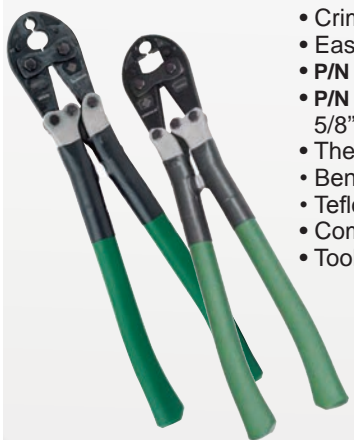

- Crimps a wide range of overhead service entrance connections, overhead splices, and overhead taps
- Easy-to-use MD-6 type "pop" tool.
- P/N 9000-02064 and P/N 9000-02065 are equipped with D₃ die groove and either "BG" or "O" die groove
- P/N 9000-08160 and P/N 9000-08161 are equipped with a die groove for Kearney® "O" dies and either a 5/8" or "O" die groove
- The D₃ die groove serves as a die seat for all Greenlee KD6 and industry "W" type dies
- Bent fiberglass handles provide a solid grip, good leverage and better durability than wood
- Teflon-impregnated bushings at pivot joints provide smooth operation and long life
- Complete crimps are assured with an over-center cam mechanism
- Tool can easily be checked visually for proper adjustment and can be adjusted with Allen wrenches

SPECIFICATIONS

INDUSTRIAL	OVERHEAD
Copper Lugs: 8-500	5/8" Service Ent. Connectors: 10-1/0
Copper Splices: 8-500	.840 Service Ent. Connectors: 1/0-4/0
Aluminum Lugs: 8-4/0	Aluminum "H" Taps: 6-4/0
Aluminum Splices: 8-4/0	Copper "H" Taps: 10-2
Copper "C" Taps: 10-2	Copper Tension Splice: 6-2/0
Aluminum "H" Taps: -	All Aluminum Tension Splice: 6-4/0
Aluminum Pin Adapters: 6-1/0 (3)	One Piece ACSR Tension Splice: 4-1/0
	Two Piece ACSR Tension Splice: 2-477
	Aluminum Jumper Splice: 4-266.8
	Stirrups: 2-4/0
	Aluminum Lugs: 2-1/0
	Copper Lugs: 6-1/0

P/N 9000-02064	K4250	D ₃ and "O" Grooves
P/N 9000-02065	K425BG	D ₃ and "BG" Grooves
P/N 9000-08160	K425K58	Kearney "O" and 5/8" Groove
P/N 9000-08161	K425KO	Kearney "D" and "O" Die Grooves

Selection Guide for GREENLEE Copper & Aluminum Cable Cutters

CABLE SIZE																				
	AWG	#8	#6	#4	#2	#1	1/0	2/0	3/0	4/0	250 kcmil	300 kcmil	350 kcmil	400 kcmil	500 kcmil	600 kcmil	750 kcmil	1000 kcmil	1500 kcmil	
	mm ²	6	10	16	25	35	40	50	70	95	120	150	150	185	240	300	400	500	800	
RATCHET																				
9700-39918 (759)	Al	•	•	•	•	•	•	•	•	•	•	•	•	•	•	•	○			
	Cu	•	•	•	•	•	•	•	•	•	•	•	•	•	○					
9700-80889 (760) & 9000-00761 (761)	Al	•	•	•	•	•	•	•	•	•	•	•	•	•	•	•	•	•	•	
	Cu	•	•	•	•	•	•	•	•	•	•	•	•	•	○	○	○	○		
9000-45206 (45206)	Al	•	•	•	•	•	•	•	•	•	•	•	•	•	•	○				
	Cu	•	•	•	•	•	•	•	•	•	•	•	•	•	•	○				
9000-45207 (45207)	Al	•	•	•	•	•	•	•	•	•	•	•	•	•	•	•	•	•	○	
	Cu	•	•	•	•	•	•	•	•	•	•	•	•	•	•	•	•	○	○	
9000-00773 (773)	Al	•	•	•	•	•	•	•	•	•	•	•	•	•	•	•	•	•	•	
	Cu	•	•	•	•	•	•	•	•	•	•	•	•	•	○					
9000-00774 (774)	Al	•	•	•	•	•	•	•	•	•	•	•	•	•	•	•	•	•	•	
	Cu	•	•	•	•	•	•	•	•	•	•	•	•	•	•	○	○			
9000-00756 (756)	Al	•	•	•	•	•	•	•	•	•	•	•	•	•	•	•	•	•	•	○
	Cu	•	•	•	•	•	•	•	•	•	•	•	•	•	•	•	•	•	•	○
MANUAL																				
9701-36930 (727) & 9700-82046 (727M)	Al	•	•	•	•	•	•	•												
	Cu	•	•	•	•	•	○	○												
9000-10507 (718F)	Al	•	•	•	•	•	•	•	•	•	•	•	•							
	Cu	•	•	•	•	•	•	•	•	•	○	○	○							
9000-24564 (704)	Al	•	•	•	•	•	•	•	•	•	•	•	•	○	○					
	Cu	•	•	•	•	•	•	•	•	•	•	○	○							
9000-05923 (705)	Al	•	•	•	•	•	•	•	•	•	•	•	•	•	•	•	•	•	○	
	Cu	•	•	•	•	•	•	•	•	•	•	•	•	○	○					
9000-00706 (706)	Al	•	•	•	•	•	•	•	•	•	•	•	•	•	•	•	•	•	○	
	Cu	•	•	•	•	•	•	•	•	•	•	•	•	•	•	○	○			

Note: • = Frequent use capacity ○ = maximum capacity

Selection Guide for GREENLEE ACSR, Guy Strand, & Steel Cutters

	ACSR	Std. Guy Strand	EHS Guy Strand	Ground Rod	Rebar (Schedule 60)
HYDRAULIC-TYPE					
HK520	336.4 kcmil	1/2" (13 mm) dia.		1/2" (13 mm) dia.	7/16" (11 mm)
RATCHET-TYPE					
9000-00394 (776)	636.0 kcmil*				
9700-12948 (757)	954.0 kcmil			1/2" (13 mm) dia.	
758		1/2" (13 mm) dia.	1/2" (13 mm) dia.	1/2" (13 mm) dia.	
MANUAL					
9702-16516 (749)	2/0 AWG 203				
CUTTER DIES					
00949	477.0 kcmil	5/8" (16 mm) dia.	5/8" (16 mm) dia.	5/8" (16 mm) dia.	5/8" (16 mm) dia.
KD6-27	4/0 AWG				

* For core diameters less than 0.32"

HAND TOOLS
MANUAL CUTTERS & CRIMPERS

USA: 1-877-GO ALTEC
(1-877-462-5832)

www.alteccconnect.com

KLEIN TOOLS®



Committed to manufacture the highest quality hand tools with unmatched durability and comfort for over 155 years

HAND TOOLS
MANUAL CUTTERS & CRIMPERS

USA: 1-877-GO ALTEC
(1-877-462-5832)

www.alteconnect.com

Small ACSR Ratcheting Cable Cutters

- Unique ratchet action holds cable tight and allows rapid, straight cuts with minimum effort
 - Quick-release lever opens blade at any time during operation
 - Large, finger-formed handles have limit guards and bright yellow plastic covering for comfort and high visibility
 - Hold-open spring speeds cutting action
 - Cuts ACSR and triplex cable
 - Also cuts copper up to 400 MCM, aluminum and multi-conductor cable up to 600 MCM
- P/N 9703-30038 63607



Open Jaw Cable Cutter

600 MCM Copper and 750 MCM Aluminum

- Front opening jaws for tight applications
 - Spring release lever allow for fast jaw reset in between cuts
 - Plastic covered handles with hand guards for comfort and firm grip
 - High-leverage ratchet mechanism for single-handed cutting of copper and aluminum without burrs or sharp edges
 - **Maximum Cable Cutting Capacity:** 600 MCM (300 MM²) Copper, 750 MCM (400 mm²) Aluminum
 - 1-1/8" Communication Cable
 - 11.5" overall length
 - One-year warranty
 - 2 lbs.
- P/N 9704-88101 63711



Ratcheting Cable Cutters



- High leverage ratchet mechanism for single handed cutting of copper, aluminum cables; does not leave burrs or sharp edges
- Patented two-step ratchet mechanism requires fewer strokes per cut
- Quick release opens blades easily in every cutting position
- Precision ratcheting mechanism holds cable tight and allows rapid, straight cuts with minimal effort

	<u>Klein</u>	<u>Copper</u>	<u>Aluminum</u>	<u>Comm.</u>	<u>Length</u>	
	<u>P/N</u>	<u>63060</u>	<u>400 kcmil</u>	<u>600 kcmil</u>	<u>1 1/8"</u>	<u>10 1/4"</u>
P/N 9000-63060	63060	400 kcmil	600 kcmil	1 1/8"	10 1/4"	

* Frequent use capacity; maximum capacity is 1000 kcmil



High-Leverage Cable Cutter

- This handy, economical tool handles most cable-cutting jobs with ease
- Cable-gripping, shear-type jaws cut up to 4/0 aluminum (not ACSR); up to 2/0 soft copper; up to 100 pair, 24-gauge communication cable
- Makes clean, efficient cuts. Ideal for working in confined spaces
- Special high-leverage design
- Tough, comfortable, red plastic-dipped handles
- Compact, only 9 1/2" long

P/N 9000-63050 Klein 63050



25" Standard Cable Cutter

- Lightweight, yet efficient shear-type cable cutters
- Replaceable hook-jaw blades grab and hold cable while shear-cutting action makes clean cuts
- Exceptionally strong fiberglass handles with heavy vinyl grips for comfort and slip resistance
- Heavy-duty pins in head serve as blade-stops
- Jaws are forged tool steel with black-oxide finish for long life
- Beveled tips assure positive mating, and hinge on a rugged bolt with a pin-set nut to maintain proper blade tension
- Not designed for cutting steel or ACSR
- Make a clean, even cut for ease in fitting lugs and terminals

P/N 9706-40802 63041TH 25" Loppers, Cable Cutters; Includes Rubber Sleeves
 P/N 9007-63041 63041 25" Loppers, Cable Cutters
 P/N 9000-63045 63045 32" Loppers, Cable Cutters

Utility Cable Cutter

- Forged steel with black-oxide finish for long life; non-slip vinyl grips
- Beveled tips for positive mating
- Shear-type hook jaws grab and hold cable while shear-cutting action makes clean cuts
- Hinge bolt with pin-set nut for proper blade tension
- Not designed for cutting steel or ACSR

P/N 9701-85318 63035



Klein Bolt Cutters

- Strong, lightweight, general purpose bolt cutters in three different sizes
- Heavy vinyl grips for comfort and slip resistance
- All-purpose, center cut jaws for soft, medium, and hard metals
- Drop forged, alloy steel jaws are precision ground for sure, efficient cutting and long life
- Lockplate reinforcement prevents jaw bolts from loosening or turning, keeps jaws in correct alignment
- One adjustment realigns cutting edges
- Three-point toggle joint multiplies 50 lbs. of hand pressure on handles to 4,000 lbs. at cutting jaws

P/N 9000-63324 63324 Steel 24" 5 1/4 lbs.
 P/N 9000-63330 63330 Steel 30" 8 1/2 lbs.
 P/N 9000-63336 63336 Steel 36" 12 3/4 lbs.
 P/N 9000-63118 63118 Fiberglass 18 1/4" 3 13/20 lbs.
 P/N 9000-63124 63124 Fiberglass 24 1/2" 4 1/2 lbs.
 P/N 9000-63130 63130 Fiberglass 30 1/2" 7 1/2 lbs.
 P/N 9000-63136 63136 Fiberglass 36 1/2" 11 1/2 lbs.



BURNDY[®] Manual Crimping Tools

HAND TOOLS
MANUAL CUTTERS & CRIMPERS

USA: 1-877-GO ALTEC
(1-877-462-5832)

www.alteconnect.com

MD6 HYTOOL™ SERIES Manual Crimping Tools

- Accepts the full line of BURNDY[®] "W" and "X" die inserts; #14-4/0 AWG
- Crimping force of 9,000 lbs.
- **P/N 9000-99875** installs CRIMPIT™ and HYCRIMP™ tap connectors with one additional die insert (W-O)
- Designed to provide over 90,000 reliable crimps installing full tension and non-tension connectors
- 25-3/8" long
- Hickory handles



P/N 9000-99875	MD6	D3 & BG Grooves
P/N 9706-37131	MD66	D3 Grooves (Snub Nose)
P/N 9000-06688	MD68	D3 & O Grooves

MD7 HYTOOL™ SERIES Manual Crimping Tools

- Integral visual wear indicator
- Life cycle tested to over 99,000 crimp cycles
- Accepts the full line of "W" and "X" die inserts
- Positive-lock, spring loaded die retainer buttons
- Crimping force of 9,000 lbs.
- Installs a full range of connectors (taps, splices, terminals)
- Conductor range: #14-4/0
- Lightweight, durable polymer handles



P/N 9000-76543	MD7	D3 & BG Grooves
P/N 9706-37132	MD76	D3 Grooves (Snub Nose)
P/N 9700-15011	MD78	D3 & O Grooves

Y35 HYPRESS™ SERIES 12 Ton Hydraulic Tools



- Hook style head with extensive ram travel for easy tapping and splicing of overhead lines as well as HYGROUND[®] compression grounding systems
- **P/N 9700-69834** body and handles are covered with 3/16" rubber for tool impact protection
- **P/N 9701-05606** HYPRESS™ head, body, and handles are covered with 3/16" rubber for tool impact protection
- Versatile and economical tool works with all commonly used copper, aluminum #8-750 kcmil and ACSR conductors from #6 str.-556.5 kcmil
- Accepts all BURNDY[®] "U" Dies

P/N 9700-69834	Y35
P/N 9701-05606	Y35-2 (Rubber Covered Head)

Y750 HYPRESS™ SERIES 12 Ton Hydraulic Tools



- Conductor range #14-750 kcmil Cu/Al and #4-556.5 kcmil ACSR; 1.65" wide jaw opening; C-shaped head rotates 355°
- Provides easy tapping, splicing and terminating of overhead lines, the full line of HYGROUND[®] compression grounding connectors, NEC cable connections and N30-N650 Navy cable connections
- Accepts all BURNDY[®] "U" dies
- **P/N 9704-57098** HYPRESS™ has a rubber covered head and handles for tool impact protection

P/N 9701-05607	Y750HSXT
P/N 9704-57098	Y750CHSXT (Rubber Covered Head)

RCC336, RCC556 & RCC954ACSR1K

Ratchet Cable Cutters

- High quality precision cutters designed to cut up to 954 ACSR and 1000 kcmil copper and aluminum
- Equipped with rugged steel blades and bi-directional ratchet (excluding RCC336) mechanism for positive blade control
- Rapid blade advance
- Comfortable tool operation and long life
- Easy cutting with minimal cable distortion
- Excellent cutting edge performance

Altec Number	BURNDY Number	Max. Cutting Capacity
P/N 9702-69756	RCC336	350 kcmil Cu 500 kcmil AL 336 kcmil ACSR
P/N 9701-05612	RCC556	500 kcmil Cu 500 kcmil AL 556 ACSR
P/N 9703-58666	RCC954ACSR1K	1000 kcmil Cu 1000 kcmil AL 954 kcmil ACSR



OUR840 HYTOOL™

Ratchet Crimping Tool



- One hand, full cycle ratchet tool for Cu, Al and ACSR
- Great for use in tight spaces where other tools can't fit
- #8-4/0 Al and #8-250 Cu terminals and splices on code conductor
- W28K cutter die permits use of tool as a cable cutter
- Uses reduced handle force on "X" and select "W" dies

- Proper crimps are assured with full cycle ratchet mechanism
- Connections are UL Listed when color-coded dies are used to install recommended BURNDY® terminals and splices.

P/N 9701-11226 OUR840

OH25 HYTOOL™

Ratchet Crimping Tool

- Full cycle dieless ratchet tool
- Easy one-hand operation with spring loaded comfort grip handles
- Ratchet mechanism provides proper crimp, uniform installations
- Forged steel jaws and stainless steel indenter
- Installs 5/8" INSULINK™ and LINKIT™ service entrance connectors, conductor range #10-1/0 AWG with only one crimp

P/N 9700-20544 OH25



BTW SERIES

Micro-Adjustable Ratchet Torque Wrenches



- Ratcheting, calibrated dual direction for ease of use in the field
- Positive lock with spring-loaded pull-down lock ring to assure that the torque setting is properly engaged and secure
- Scale settings on tool correspond to connector torque ratings (in-lb); fast, accurate and easy-to-set values
- Lightly knurled handle offers an ergonomic, non-slip grip
- Micro-adjustable design minimizes the need for several wrenches
- Individually serialized and calibrated traceable to N.I.S.T.
- P/N 9703-58669 BTW30150 designed for use on connectors requiring torque values from 30 to 150 in-lbs.
- P/N 9703-58673 BTW150750 designed for use on connectors requiring torque values 150 to 750 in-lbs.
- P/N 9704-39469 BTW1575F12 is designed for applications requiring a 1/2" drive and torque values from 15 to 75 ft-lbs.

P/N 9703-58669 BTW30150 3/8" Drive
 P/N 9703-58673 BTW150750 3/8" Drive
 P/N 9704-39469 BTW1575F12 1/2" Drive

H.K. Porter 0890SMC Compact Bolt Cutter - Co-Mold, Spring, Lock

- Induction hardened center cut blades
- Recessed notch blade design holds cutting material close for extreme cutting power
- Co-mold handles for superior comfort with repetitive cutting
- User friendly, robust locking device that is easy to use with gloves
- Heavy duty spring creates a smooth cutting operation and is ideal for repetitive cutting
- Compact bolt cutters w/spring return, straight-center cut, co-mold grips, latch, precision engineered recessed throat notch for maximum leverage requires 50% less effort, induction hardened jaws
- Cuts wire bolts, rivet, springs small chain, fence, and more
- Capacity: soft (cooper aluminum) .24", Medium (nails, rivets, light chain) .20", Hard (steel, wire, wire rope strands, chicken wire) .16", Very hard (spring steel, piano wire) .15".



P/N 9706-37571 0890SMC

H.K. Porter 0890MA Compact Bolt Cutter - Co-Mold, Spring, Lock

- Induction hardened cutting edges for ultimate durability
- Recessed notch blade design holds cutting material close for extreme cutting power
- Easy to clean industrial plastic dipped handle grips
- Cuts mild steel (80,000 PSI) to 1/4", 6mm diameter
- Cuts very hard steel (285,000 PSI) to .14", 3.8mm diameter
- Compact bolt cutters, angled jaw-flush cut (can be positioned flat on surface, makes nearly flush cut, perfect when finish is important), plastic handles, precision engineered recessed throat notch for maximum leverage requires 50% less effort, induction hardened jaws
- Cuts wire bolts, rivet, springs small chain, fence and more
- Capacity: soft (cooper aluminum) .24", Medium (nails, rivets, light chain) .20", Hard (steel, wire, wire rope strands, chicken wire) .16", Very hard (spring steel, piano wire) .15".



P/N 9706-37572 0890MA

H.K. Porter Pivot Handle Cable Cutter

- For utility underground distribution mechanics
- Power Cable 500 to 750MCM
- Pivoting lightweight fiberglass handles, ratcheting cable
- Provides better hand positioning at the start of the cut
- After initial cut, handles can be fully extended position for the greatest leverage
- Heavy duty clevis design adds strength and protects ratchet mechanism
- Compact adjustable handle design for access in to tight spaces, trenches, vaults and manholes
- Pivot handle significantly lessens handle footprint, making cuts in vaults and trenches easier
- Ultra robust ratchet mechanism utilizes clevis design for protection against damage and heavy use



P/N 9706-37573 1490PHFCS* 20" Overall Length
P/N 9706-37574 0290PHFCS* 26" Overall Length
* Will be released February, 2015



H.K. Porter Ratchet Type, Guy Strand Cutter



- Notched shear-cut blades hold material firmly in place
- Ratchet and chain produce easy, progressive cuts
- Cuts up to 1/20", 13 mm EHS guy strand, mild steel rods and bolts, and similar materials
- Makes clean, square cuts with minimal distortion
- Increased mechanical advantage over manual cutters

P/N 9000-08690 8690CK 28" Length

H.K. Porter 29 1/4" Ratchet-Type Hard Cable Cutters

- Jaw keeper prevents jaws from spreading while under a heavy load
- Cuts hard cable up to 1 3/16", ACSR, ACAR, ZEBRA, and self-supporting telephone cable
- Allows short strokes in confined spaces
- Ratchet and chain increase cutting pressure
- Shear-cut blades
- 29.25" long
- 12.4 lbs.

P/N 9007-08690 8690FH



H.K. Porter Guy Cutters

- Ratchet-type jaw with notched shear-cut blades
- Blades hold and lock material in place
- Cuts aircraft cable, EHS guy strand, wire rope and stainless steel cable
- Increased mechanical advantage over manual cutters
- Cuts all strands with minimal crushing or distortion
- 36" long

P/N 9007-86900 8690TN





HAND TOOLS
MANUAL CUTTERS & CRIMPERS

H.K. Porter Cutters

- Lockplate keeps jaws from loosening; Screw-type adjustment realigns edges
- Toggle joints turn 50 lbs. hand pressure to 4000 lbs. cutting pressure

ALTEC	HK PORTER	LENGTH	Soft and Medium Hard Materials (Up to Brinell 300, Rockwell C31)	Hard Materials (Up to Brinell 455, Rockwell C48)	Replacement Cutterhead/Jaws	
General Purpose, Center Cut Cutters (Fiberglass Handles)						
9007-00090	0090FC	18 1/4"	3/8", 10 mm	1/4", 6 mm	9702-75190	0013C
9000-11990	0190FC	24 1/2"	7/16", 11 mm	5/16", 8 mm	9702-75190	0013C
9700-66906	0290FC	30 1/2"	1/2", 13 mm	3/8", 10 mm	9702-12070	0213C
9702-57872	0390FC	36 1/2"	9/16", 14 mm	7/16", 11 mm	9000-50183	0313C
Heavy Duty Bolt Cutters (Fiberglass Handles)						
9702-36738	0190FCX	24"	5/16", 8 mm	5/16", 8 mm	900050525	0113CX
9702-36908	0290FCX	30"	3/8", 10 mm	#3 Bar, 3/8", 10 mm		0213CX
9700-91061	0390FCX	36"	7/16", 11 mm	7/16", 11 mm		0313CX
Industrial Grade, Center Cut Cutters (Steel Handles)						
9701-36397	1490MC	14"	5/16", 8 mm	3/16", 5 mm		1413C
9700-81291	0090MC	18"	3/8", 10 mm	1/4", 6 mm	9702-75190	0013C
9000-88894	0190MC	24"	7/16", 11 mm	5/16", 8 mm	9702-75190	0013C
9000-70024	0290MC	30"	1/2", 13 mm	3/8", 10 mm	9702-12070	0213C
9700-99032	0390MC	36"	9/16", 14 mm	7/16", 11 mm	9000-50183	0313C
9706-37575	0590MC	42"	11/16", 18 mm	1/2", 13 mm		0513C
9701-31789	0590MCX	42"	1/2", 13 mm	#4 Bar, 1/2", 13 mm		0513CX



***NEVER**
Use Any HK
Porter Cutter
On Energized
Lines, Circuit
Or Wires

PROUDLY MADE IN THE



HASTINGS

A WORLDWIDE SUPPLIER OF
Hot Line Tools & Equipment

HASTINGS MANUAL CUTTERS

USA: 1-877-GO ALTEC
(1-877-462-5832)

www.alteconnect.com

Hand Held ACSR Ratchet Cutter



- Max cable 336 ACSR
- Release lever allows cutter jaws to be opened at any time
- Handles are plastic dipped for comfort and a non-slip grip
- Compact size allows cutter to be used under close working conditions

P/N 9700-18238 11-014

High Tensile Steel Bolt Cutters



- Replaceable insulated fiberglass handles
- Suitable for cutting hard material
- Capacities: 3/8" reinforced steel, 5/16" diameter bar steel or steel wire, and 9/32" diameter music wire
- Handles filled with unicellular foam core
- Cam hinge bolts for jaw alignment
- Replacement head available
- 24" long

P/N 9700-54983 10-667

954 ACSR Ratchet Cutters



- Allows for confined space cutting with offset cutting head
- Selection lever for "open" or "close" jaws
- Ratchet drive mechanism requires less force and leverage
- Handle plunger allows for "fast advance" or "fast retraction"
- Heat treated jaws with a keeper on the upper jaw to prevent blade separation while cutting

P/N 9701-62322 10-207 Ratchet Cutters
P/N 9701-62323 01-4002 Case

Heavy Duty "EHS" Guy Strand Cutters



- Progressive cutting action - superior cutting of guy strand over typical bolt cutters
- Designed for cutting 1/2" EHS guy strand
- Fiberglass handles
- Weighs 11.25 lbs.
- Release lever allows cutting jaw to be opened
- Cutting jaw retracts into main body and cuts guy strand as handles are opened and closed

P/N 9700-57161 10-260



CUTTERS & CRIMPERS

A.B. Chance Hydraulic Conductor Ratchet Cutters



- Half the size, weight of standard ratchet cutters
- Useful for confining workspaces such as manholes and handholes
- Built to withstand punishing field conditions
- Open in less than half the space required for long-handled ratcheting cutters
- Guillotine, C-type jaws are heat-treated for lasting strength and sharpness
- Reinforced fiberglass handles

are PVC-coated and protected by a vinyl sleeve

- Cuts up to 556 ACSR or 750 MCM AA/CU
- 18" long
- 4.4 lbs.

P/N 9007-40329 Chance C4032980

Bolt Cutters with Fiberglass Handles

- Fiberglass handles tested 100 kV per 12"
- Suitable for cutting up to 3/8" capacity high tensile material
- Short cutting edge for high tensile steel bolts, wire, rod, chain links, and case hardened chains

P/N 9700-89245 18" overall length
P/N 9700-89247 24" overall length



Cable Crimper - Fixed Die

- Rust-resistant
- Weight: 3.8 lbs.
- Length: 21.42"
- Crimps #2, #4, and #6 connectors safely and easily
- Features extra-heavy duty fiberglass handles
- Molded rubber grip handles are ergonomically designed to fit the contour of the human hand for increased comfort, slip-resistance



P/N 9701-82291

AMPACT TOOLS

AMPACT Installation Tool



- Small AMPACT tool for red, and blue-coded taps; Aluminum wire combinations: #8 thru 350 kcmil
- Large AMPACT tool for yellow-coded taps only; Aluminum wire combinations: 336.4 thru 1192.5
- Auxiliary Platform is required to install red-coded standard taps with small AMPACT tool

P/N 9000-69437 Small Tool
P/N 9000-69611 Large Tool

AMPACT Aluminum Tap System Tool



- RoHS and ELV compliant
- Not relevant for lead-free process
- ONLY for use with AMPACT tools
- Polyethylene; contains propellant and primer

• Color-coded to match taps and stirrups

P/N 9000-69381 Blue
P/N 9000-69384 Yellow
P/N 9000-69382 Red
P/N 9000-69338 White

AMPACT Take-Off Clip



- RoHS and ELV compliant
- Not relevant for lead-free process
- Polyethylene
- Removes connector cap tap system tool

P/N 9000-69684 Used in Type II red-coded taps
P/N 9000-69847 Used in yellow-coded taps
P/N 9000-69947 Used in Type II white-coded taps

AMPACT Heads



- RoHS and ELV compliant
- Not relevant for lead-free process
- AMPACT head; alloy steel
- Large head - for use with yellow coded taps
- Small head - use with red, white, blue-coded taps

P/N 9000-69633 Large head - for use with 9000-69611
P/N 9000-69667 Small head - for use with 9000-69437

Cleaning Tool for AMPACT Tools



- Cleans caps, breach assembly, threads, and any other part of the tool
- WD-40 or anything containing petroleum is not recommended to clean tools
- Use 3-in-1 oil or Hoppes Oil #9 to clean tools

P/N 9000-31419 Cleaning Tool

PowerBlade™ 750 Cable Cutter



- Extremely versatile and designed for multiple applications
- Jaw opening of 1½"
- Cuts copper cable up to 750MCM and aluminum cable up to 1000MCM
- Specially hardened, rounded blades minimize cable

distortion for professional quality every time

P/N 9700-65232 35-078

Big Kahuna™ Cable Cutter



- Rock Solid power blade designed for heavy duty applications involving large diameter cable
- 3 1/2" jaw opening
- Cuts through most large-diameter cable
- Leaves a clean, installation-ready cut each time, every time

- Superior blade durability, Cuts copper and aluminum up to 1250 MCM

P/N 9706-40805 35-076

Merlin ACSR Cable Cutter



- Especially designed for applications involving stainless steel reinforced aluminum cable
- Jaw opening of 3/4" for precision and accuracy
- Cuts up to 3/4" Merlin ACSR

P/N 9706-40804 35-077

TKO™ Carbide Tipped Hole Cutter 4 Piece Kit



- SmoothStart™ pilot drill prevents carbide damage by gradually guiding cutter to material
- Precision ground carbide teeth for fast cutting of clean, round holes
- Designed specifically for sheet metal cutting, even stainless steel
- Over drill flange built in to prevent penetration beyond the sheet metal

P/N 9701-84084 36-311

TKO™ Carbide Tipped Hole Cutter 8 Piece Master Electrician's Kit

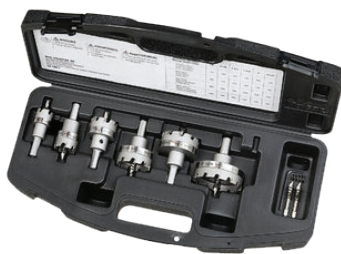

- SmoothStart™ pilot drill prevents carbide damage by gradually guiding cutter to material
- Precision ground carbide teeth for fast cutting of clean, round holes
- Designed specifically for sheet metal cutting, even stainless steel

- Over drill flange built in to prevent penetration beyond the sheet metal
- Includes cutters for all conduit sizes from 1/2" to 2" conduit along with two spare SmoothStart™ pilot bits and a convenient carrying case

P/N 9706-40806 36-314

Electrician's Step Bit Kit



- Durable blow-molded case securely holds and protects bits
- Kit includes four step bits (35-511, 35-513, 35-515, and 35-517)
- Kit provides a solution for every electrical hole size between 1/8" and 1-3/8"

P/N 9701-84351 35-520



Gator® EK425L Battery-Powered Crimping Tool



**POWER TOOLS
BATTERY POWERED TOOLS**

**USA: 1-877-GO ALTEC
(1-877-462-5832)**

www.alteconnect.com

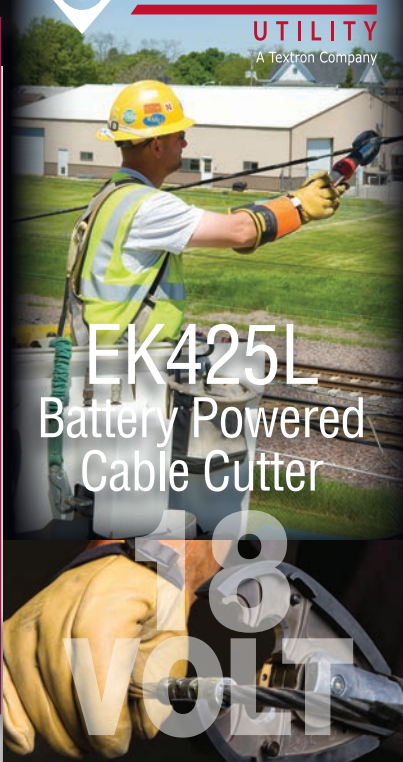

**EK425L
Battery Powered
Cable Cutter**

**EK425L
CRIMPING TOOL**

*Jaws open automatically
when crimp is complete*

*Interchangeable cutting and
crimping jaws*

*Rotates 350° to fit in tight
spaces*

325 crimps per battery charge

4 second cycle time

*Slim, lightweight profile for
one-handed operation*

*Choice of 120V, 12V or 230V
battery chargers*



More Power

- 18V Lithium-Ion battery provides 20% shorter cycle times (4 sec.) and 80% more cycles per charge (up to 325)
- 6 tons of crimping force

More Intelligent

- An exclusive pressure sensor monitors the crimping force of each crimp and provides the operator a visual and audible alert if the force is below specifications
- LED light provides the operator with the battery charge status and tool maintenance status
- Smart chargers maximize battery life

More Ergonomic

- One trigger controls all tool functions, ram automatically retracts when crimp is complete
- LED work light illuminates dark work areas
- Over molded tacky grip areas make gripping the tool easier and more comfortable

More "Green"

- Greenlee battery-powered crimping tools now use biodegradable oil.

More Flexibility

- With a wide variety of crimping and cutting heads, the EK425L is the most versatile tool of its type in the market.
- No other battery-powered tool gives the operator the comfort of knowing that each crimp was made with the correct force.

Other Features

- Length is only 18 1/2", weighs only 6.8 lbs.
- Includes two batteries, battery charger, and a convenient rubberized canvas bucket pouch
- CJD3BG, CJD3O, CJK, & CJD3 crimping jaws have rubber covers on outside edges
- When equipped with CJD3BG, CJD3O, CJK, & CJD3 crimping jaws, can be used with all industry "W" style crimping dies
- When equipped with CJK crimping jaws, can be used with Kearney type "O" dies

ALTEC P/N	CAT NO.	DESCRIPTION
EK425 TOOLS		
9702-18574	EK425LD011	EK425 Tool; CJD30 Crimping Jaws, 120 Volt
9702-18576	EK425LDBG11	EK425 Tool; CJD3BG Crimping Jaws, 120 Volt
9702-16517	EK425LD11	EK425 Tool; CJD3 Crimping Jaws, 120 Volt
9702-18578	EK425LK11	EK425 Tool; CJK Crimping Jaws, 120 Volt
9702-18575	EK425LD012	EK425 Tool; CJD30 Crimping Jaws, 120 Volt
9702-18577	EK425LDBG12	EK425 Tool; CJD3BG Crimping Jaws, 12 Volt
9702-16518	EK425LD12	EK425 Tool; CJD3 Crimping Jaws, 12 Volt
9702-18581	EK425LK12	EK425 Tool; CJK Crimping Jaws, 12 Volt
9702-18542	EK425LB	EK425 Base Tool, 2 Batteries
9702-89711	EK425L	EK425 Base Tool Only
ACCESSORIES		
9700-15446	KD6-27	"W" Style Cutter Dies for ACSR to 4/0 AWG
9700-91478	43136	Kearney "D" Crimping Die (Adapts CJK Jaws to accept "W" & "X" Dies)
9702-16519	52176	Replacement 18V 3.0 Ah Li-ion Battery
9702-16795	52178	120V Charger (for use with all NEW Greenlee "L" Series Tools)
9702-16796	52179	12V Charger (for use with all NEW Greenlee "L" Series Tools)



Gator® EK425L Crimping Jaws



P/N 9700-15445
CJK Crimping Jaws
• Kearney dies for Type "O" tools
*Requires P/N 9700-91478 Adapters



P/N 9700-89227
CJXPJ Crimping Jaws
• Nicopress connectors that require the X, P, or J tool grooves



P/N 9000-84513
CJB Cutting Jaw
• One time disposable lock hasps, 4AWG Alumoweld
• ACSR 1/0 (does not fully cut through all of the aluminum strands; cable must be flexed to complete the separation)



P/N 9700-15444
CJD3 Crimping Jaw
• Includes D3 die groove



P/N 9700-80111
CJD3BG Crimping Jaw
• Crimps jaw for D3 and BG die grooves



P/N 9700-80112
CJD3O Crimping Jaw
• Crimps jaw for D3 and O die grooves



EK425 Pouch

- Fabricated out of durable vinyl
- Combine with "S" hooks to attach bag to the inside/outside of a platform (not included)
- Velcro® closures keep the tool clean
- Crimping jaws do not need to be removed when storing the tool

P/N 9000-11001 CP1



EK425 Vinyl Carrying Cases

- Designed to hold the Greenlee EK425L crimping tool
- Fabricated out of durable vinyl
- Combine with "S" hooks to attach bag to the inside/outside of a platform (not included)

P/N 9000-96164 Pouch
P/N 9000-96165 Pouch with Handle and Belt Strap
P/N 9000-96185 Pouch with Handle, Belt Strap, and Cover



UTILITY
A Textron Company



CJD3BG, CJD3O, CJK* Crimping Jaws Compatibility

- Greenlee® KD6 Series
 - FCI Burndy® W,X Series
 - IlSCO® ND Series
 - Huskie® HT-58 Series
 - Panduit® CD-2001 Series
- *Requires P/N 9700-91478 Adapters

EK425L CRIMPING JAW COVERS

P/N 9701-02811
Single Die Set Jaw Covers
Set of (2) Jaw Covers
for Single Die Sets CJO/CJD3

P/N 9701-02813
Dual Die Set Jaw Covers
Set of (2) Jaw Covers
for Dual Die Sets CJD3O/CJD3BG



* Crimping jaws do not need to be removed when storing the tool

POWER TOOLS
BATTERY POWERED TOOLS

USA: 1-877-GO ALTEC
(1-877-462-5832)

www.alteconnect.com

GREENLEE BATTERY POWERED TOOLS

Professional Crimping Tools

POWER TOOLS
BATTERY POWERED TOOLS



Gator® 22-Series 6-Ton Crimping Tool

- 18V Lithium-Ion battery provides more cycle times and faster cycles
- An exclusive pressure sensor monitors the crimping force of each crimp and provides the operator a visual and audible alert if the force is below specifications.
- Automatic Retraction Stop (ARS) stops the ram retraction automatically at the correct position for the next crimp cycle reducing subsequent cycle times
- LED work light illuminates dark work areas
- One trigger controls all tool functions, ram automatically retracts when crimp is complete
- Over molded tacky grip areas make gripping the tool easier and more comfortable
- 6 ton crimping force, Flip-style crimping head opens easily and rotates 35°
- Uses Greenlee K22 dies and industry "W" dies
- Includes (2) 18V 1.5 Ah Li-ion batteries, battery charger, molded carrying case, and die adapters for "W" dies

P/N 9000-88833 EK622L11 120 Volt Charger
P/N 9000-03552 EK622L12 12 Volt Charger

Gator® L-Series 6-Ton Crimping Tool

- 18V Lithium-Ion battery provides more cycle times and faster cycles
- An exclusive pressure sensor monitors the crimping force of each crimp and provides the operator a visual and audible alert if the force is below specifications
- LED work light illuminates dark work areas
- One trigger controls all tool functions, ram automatically retracts when crimp is complete
- Over molded tacky grip areas make gripping the tool easier and more comfortable
- 6 ton crimping force, crimping rotate 350°
- Uses Greenlee KC22 dies for copper connectors 8 AWG – 600 kcmil and Greenlee KA22 dies for aluminum connectors 8 AWG – 350 kcmil
- Includes two 18V 1.5 Ah Li-ion batteries, battery charger, and molded carrying case

P/N 9700-72158 EK628L11 120 Volt Charger
P/N 9702-21685 EK628L12 12 Volt Charger
P/N 9700-15444 CJD3 Crimping jaws for all industry "W" style dies
P/N 9700-15445 CJK Crimping jaws for Thomas & Betts "6 Ton" dies



Gator® L-Series 12-Ton Crimping Tools

- 18V Lithium-Ion battery provides more cycle times and faster cycles
- An exclusive pressure sensor monitors the crimping force of each crimp and provides the operator a visual and audible alert if the force is below specifications.
- Automatic Retraction Stop (ARS) stops the ram retraction automatically at the correct position for the next crimp cycle reducing subsequent cycle times
- LED work light illuminates dark work areas
- 12 ton crimping force, crimping head rotates 350°
- One trigger controls all tool functions, ram automatically retracts when crimp is complete
- Over molded tacky grip areas make gripping the tool easier, more comfortable
- Uses Greenlee 12-ton dies and industry "U" dies
- Includes two 18V 3.0 Ah Li-ion batteries, battery charger, and molded carrying case

P/N 9000-81833 EK1230L11 120 Volt Charger
P/N 9000-81834 EK1230L12 12 Volt Charger
For industry "U" style dies, jaw opening is 1.2"

P/N 9702-18582 EK1240L11 120 Volt Charger
P/N 9702-18584 EK1240L12 12 Volt Charger
For industry "U" style dies, jaw opening is 1.65"

P/N 9702-18585 EK1240KL11 120 Volt Charger
P/N 9702-18586 EK1240KL12 12 Volt Charger
For use with Kearney PH2 style dies



Greenlee EK1240L

Greenlee EK1240KL

Greenlee EK1230L

Replacement Batteries and Chargers for Gator "L" Series Tools

P/N 9702-16519 52176 18 V 3.0 Ah Li-ion battery
P/N 9702-16794 52177 18 V 1.5 Ah Li-ion battery
P/N 9702-16795 52178 120V Charger
P/N 9702-16796 52180 12V Charger

USA: 1-877-GO ALTEC
(1-877-462-5832)

www.alteconnect.com



Gator® L-Series Quad-Point Crimping Tools

- 18V Lithium-Ion battery provides more cycle times and faster cycles
- An exclusive pressure sensor monitors the crimping force of each crimp and provides the operator a visual and audible alert if the force is below specifications
- Automatic Retraction Stop (ARS) stops the ram retraction automatically at the correct position for the next crimp cycle reducing subsequent cycle times
- LED work light illuminates dark work areas
- One trigger for all tool functions, ram automatically retracts when crimp is complete
- Over molded tacky grip areas make gripping the tool easier and more comfortable
- 6.2 ton crimping force, crimping head rotates 350°
- Tools utilize 4 indenters to make a crimp
- Includes two 18V 3.0 Ah Li-ion batteries, battery charger, molded carrying case, test gauge, test slugs

P/N 9000-81829 EK06ATL11 120 Volt Charger Cuts Copper Lugs & Copper Splices: 4-500
 P/N 9000-81830 EK06ATL12 12 Volt Charger Cuts Copper Lugs & Copper Splices: 4-500
 P/N 9000-88834 EK06FTL11 120 Volt Charger Cuts Copper: 4-750; Aluminum: 6-750*
 P/N 9000-88835 EK06FTL12 12 Volt Charger Cuts Copper: 4-750; Aluminum: 6-750*

* Additional Overhead Specifications: 58" Service Ent. Connectors: 8-1/0; .840 Service Ent. Connectors: 4-350; Copper Tension Spliced: 6-4/0; One Piece ACSR Tension Splice: 4-477



Greenlee EK06ATL

Greenlee EK06FTL

Gator® L-Series Dieless Crimping Tool

- 18V Lithium-Ion battery provides more cycle times and faster cycles
- An exclusive pressure sensor monitors the crimping force of each crimp and provides the operator a visual and audible alert if the force is below specifications
- Automatic Retraction Stop (ARS) stops the ram retraction automatically at the correct position for the next crimp cycle reducing subsequent cycle times
- LED work light illuminates dark work areas
- One trigger controls all tool functions, ram automatically retracts when crimp is complete
- Over molded tacky grip areas make gripping the tool easier and more comfortable
- Indent style crimp, crimping head rotates 350°
- Flip-open crimping head allows crimping of 4 AWG – 1000 kcmil copper and 6 AWG -1000 kcmil aluminum with no dies to change
- Includes two 18V 3.0 Ah Li-ion batteries, battery charger, and molded carrying case

P/N 9701-10712 EK12IDL11 120 Volt Charger
 P/N 9701-10715 EK12IDL12 12 Volt Charger



Gator® 15-Ton Crimping Tool



EK1550L

- Intelligent Crimping System Technology includes a pressure sensor that monitors the crimping force of each crimp and provides the operator a visual and audible alert if the force is below specifications.
- State of the art 18V lithium ion (Li-ion) battery provides 70% more cycles per charge and faster cycle times.
- Automatic Retraction Stop (ARS) which retracts the ram just enough to get ready for the next cycle saving time and energy.
- LED light provides the operator with the battery charge and tool maintenance status
- Two-stage hydraulic system provides fast advance and power speeds, saving time
- Forward handle position improves tool balance.
- One trigger controls all tool functions.
- Crimping head rotates 350°
- Tools automatically retract when the crimping cycle is complete
- Overmolded tacky grip areas make gripping the tool easier and more comfortable

- Interchangeable adapters permit the use of a wide variety of crimping dies. Accepts Kearney PH4/P14 dies without adapter
- Available with 120V, 12V or 230V battery charger or with 120V or 230V corded adapter in place of batteries and charger
- Smart chargers control the charging current, charging voltage and battery temperature to maximize battery life
- Greenlee battery-powered crimping tools now use bio-degradable oil
- Assist handle is included to provide better balance for the tool
- LED work light illuminates dark work areas.

P/N 9702-16797 EK1550L11 Features 120 Volt Charger
 P/N 9702-16798 EK1550L12 Features 12 Volt Charger

POWER TOOLS
BATTERY POWERED TOOLS

USA: 1-877-GO ALTEC
 (1-877-462-5832)

www.alteconnect.com

15 TON

**LOW PRESSURE
BATTERY POWERED
Crimping Tool**

More Capacity

~Improved Consistency

- Increased crimping capacity of up to 1250 MCM aluminum and 1500 MCM copper color coded lugs and splices
- Stable, symmetrical and consistent

Improved Usability

~32% Weight Reduction

- Weight reduction and improved balance provide less fatigue over time
- Weighs 16.3 lbs.
- The EK Battery version weighs a mere 16.3 lb.

Safer Alternative

~Enclosed Crimping Head

- Features Greenlee's patented "Quick Release" spring loaded locking mechanism for faster engagement.
- Tool head rotates 350°
- Uses a self-centering chamfered pin for easy head closure

**LOW PRESSURE
15 Ton Crimping Tool**



P/N 9704-00377

**HIGH PRESSURE
Remote Crimping Head**



P/N 9704-00361



P/N 9704-00366



- Intelli-CRIMP™ Technology includes a pressure sensor that monitors the crimping force of each crimp and provides the operator a visual and audible alert if the force is below specifications
- Automatic Retraction Stop (ARS) retracts the ram just enough to get ready for the next cycle, saving time and energy
- 18V Li-ion battery provides 70% more cycles per charge and faster cycle times
- Accepts P-style die to crimp splices and lugs up to 1500 kcmil copper and 1250 kcmil aluminum
- Accepts Greenlee KC12, KA12, and KD12 crimping dies and industry U-style dies with optional UA15T adapters
- Light weight flip-top head with patented quick release locking pin
- 2" jaw opening
- Crimping head rotates 350°
- Battery recharges in 28 minutes

ALTEC P/N	CAT NO.	DESCRIPTION
Gator® Battery-Powered 15 Ton Crimping Tool		
9704-00366	EK1550FTLU11	15 Ton Tool with 120 V Charger
9704-00367	EK1550FTLU12	15 Ton Tool with 12 V Charger
9704-00368	EK1550FTLU22	15 Ton Tool with 230 V Charger
9704-00369	EK1550FTLU120	15 Ton Tool, 120 V AC Adapter
9704-00370	EK1550FTLU230	15 Ton Tool, 230 V AC Adapter
9704-00371	UA15T	Die-Adaptors - Greenlee "U" style dies, Burndy "U" style dies, IlSCO ILD style dies, T&B 15500 style dies, Blackburn 15500 style dies
9704-00372	23492	Handle
9702-16519	52176	18V, 3.0 Ah, Li-ion Battery
9702-16795	52178	120V Charger
9702-39618	52179	230V Charger
9702-16796	52180	12V Charger

LOW PRESSURE 15 Ton Crimping Tool

- No high pressure intensifier required.
- Relief valve signals operator when crimp is complete.
- Accepts P-style die to crimp splices and lugs up to 1500 kcmil copper and 1250 kcmil aluminum.
- Accepts Greenlee KC12, KA12, and KD12 crimping dies as well as industry U-style dies with optional UA15T adapters.
- Light weight flip-top head with patented quick release locking pin.
- 2" jaw opening.
- Crimping head rotates 350°

HIGH PRESSURE 15 Remote Crimping Head

- Accepts P-style die to crimp splices and lugs up to 1500 kcmil copper and 1250 kcmil aluminum.
- Accepts Greenlee KC12, KA12, and KD12 crimping dies as well as industry U-style dies with optional UA15T adapters
- Light weight flip-top head with patented quick release locking pin.
- 2" jaw opening.
- Operates with 10,000 psi hydraulic sources.
- Equipped with 3/8" male screw-type 10,000 psi coupler.
- Crimping head rotates 350°

ALTEC P/N	CAT NO.	DESCRIPTION
Low Pressure 15 Ton Crimping Tool		
9704-00377	LPK1550FT	15 Ton Low Pressure Tool
High Pressure 15 Ton Remote Crimping Head		
9704-00361	RK1550FT	15 Ton High Pressure Tool

GREENLEE BATTERY POWERED TOOLS



**POWER TOOLS
BATTERY POWERED TOOLS**

**USA: 1-877-GO ALTEC
(1-877-462-5832)**

www.alteconnect.com

Gator® L-Series 12-Ton Multi-Purpose Tool

- Uses a variety of easily interchanged cutting blades, crimping die adapters, and a knock-out punch adapter
- 18V Lithium-Ion battery provides more cycle times and faster cycles
- LED work light illuminates dark work areas
- One trigger controls all tool functions, ram automatically retracts when crimp is complete
- Over molded tacky grip areas make gripping the tool easier and more comfortable
- 12 ton crimping force, Flip-style crimping head opens easily and rotates 350°
- Uses Greenlee 12-ton dies and industry "U" dies
- Includes two 18V 3.0 Ah Li-ion batteries, battery charger, molded carrying case, and die adapters for "W" dies

P/N 9702-21784 E12CCXL11 120 Volt Charger*
P/N 9702-21785 E12CCXL12 12 Volt Charger*

* 9700-80068 Adapters for "U" dies are included with 12CCX tools

OTHER DIES AND BLADES MUST BE PURCHASED SEPARATELY

**** 6 ton dies are compatible with the CCX tools when paired with a die adapter**

- 6 ton dies are compatible with the CCX tools when paired with a die adapter
- Dies and blades must be purchased separately

CUTTING CAPACITIES:

- Copper and aluminum cable 1 1/2"
- ACSR: 954 kcmil
- Standard guy strand: 5/8"
- EHS guy strand: 1/2"
- Ground rod: 1/2"
- Rebar: 1/2"
- Threaded rod: 1/4", 3/8" 1/2", 4mm, 5mm, 6mm, 8mm, 10mm
- DIN rail: 35 x 7.5, 32 x 15 x 9, 35 x 15

PUNCHING CAPACITIES:

- Round: 5 5/8"
- Rectangular: 2.677" x 5.433"
- Square: 5.4333" x 5.4333"
- Accessories required to punch 4 1/2" through 5 5/8": **P/N 9700-81671** spacer, **P/N 9000-04686** bushing, and **P/N 9700-81669** sleeve

CRIMPING CAPACITIES:

- Copper, color-coded lugs and splices: 750 kcmil*
- Aluminum color-coded lugs and splices: 750 kcmil**
- 5/8" service entrance connectors: 10 - 1/0 AWG
- .840 service entrance connectors: 1/0 - 4/0 AWG
- Aluminum overhead "H" taps: 6 AWG - 500 kcmil
- One piece ACSR tension splicers: 4 AWG - 556.5 kcmil
- One piece ACSR tension splicers: 4 AWG - 556.5 kcmil

* When used with Greenlee **KC12** dies in combination with Anderson, Blackburn, FCI Burndy, ILSCO, Panduit, Penn-Union, and Thomas & Betts **copper** color-coded connectors, crimps on copper lugs up to 750 kcmil are UL and cUL classified.

** When used with Greenlee **KA12** dies in combination with Anderson, Blackburn, FCI Burndy, ILSCO, Panduit, Penn-Union, and Thomas & Betts **aluminum** color-coded connectors, crimps on copper lugs up to 750 kcmil are UL and cUL classified.

Replacement Batteries and Chargers for Gator "L" Series Tools

P/N 9702-16519 52176 18 V 3.0 Ah Li-ion battery
P/N 9702-16795 52178 120V Charger
P/N 9702-16796 52180 12V Charger



DIE ADAPTERS

- P/N 9700-21641** Adapter for Greenlee K22 Dies
P/N 9000-07033 Adapter for Kearney "O", T&B "6 Ton", and Blackburn "OD" Dies
P/N 9000-07035 Adapter for Burndy "W" and Panduit "CD-2001" Dies (equivalent to "D3" die)
P/N 9700-80068 Adapter for "U" Dies (included with tool)

CABLE CUTTING BLADES

- P/N 9700-13228** Cutter Blades AL & CU 1" Capacity
P/N 9000-07036 Cutter Blades AL & CU 1 1/2" Capacity
P/N 9700-04962 Cutter Blades for ACSR and Guy Strand

KNOCKOUT PUNCH ADAPTER

- P/N 9700-80040** Punch Driver Adapter (accepts 3/4" draw stud)

* All items are sold in pairs except for the Punch Driver Adapter

THREADED ROD CUTTING BLADES

- P/N 9700-80072** Cutter Blades for 1/4" Threaded Rod
P/N 9700-80074 Cutter Blades for 3/8" Threaded Rod
P/N 9700-80075 Cutter Blades for 1/2" Threaded Rod

The CCX 3 step, 10 second function changeover

STEP 1: Just push the release buttons, and the blades slide right out of the easy opening CCX head

STEP 2: Alternate die adapters, cutter blades, or knockout punch adapters slide right in

STEP 3: You are working again - with no lost time

GREENLEE BATTERY POWERED TOOLS

Professional Cutting Tools

**POWER TOOLS
BATTERY POWERED TOOLS**

ES32LU Cable Cutter

- State of the art 18V lithium ion (Li-ion) battery provides well over 200 cycles per charge and faster cycle times
- LED light provides the operator with the battery charge and indicates tool maintenance status
- In-line tool style is light weight and very easy to control; one trigger controls all tool functions
- Cutting head rotates 350°
- Tool automatically retracts when the cutting cycle is complete.
- Over molded tacky grip areas make gripping the tool easier and more comfortable
- LED work light illuminates dark work areas
- Greenlee battery-powered tools now use bio-degradable oil
- Smart chargers control the charging current, charging voltage and battery temperature to maximize battery life
- Available with 120V or 12V battery charger
- Includes (2) 18V 3.0 Ah Li-Ion batteries, a charger, and molded carrying case

P/N 9703-54901 ES32LU11 120 Volt Charger
 P/N 9703-54904 ES32LU12 12 Volt Charger
 P/N 9000-02178 02178 120V Charger only
 P/N 9000-99493 03048 12V Charger only



ES25 ACSR Cable Cutter

- Cuts up to 636 kcmil ACSR cables
- Approximately 50 cuts of Grosbeak or 120 cuts of Merlin per battery charge
- Includes one hour battery charger, one battery, and molded carrying case

P/N 9000-22131 ES25 120 Volt Charger
 P/N 9701-18121 76807 Blade Kit
 P/N 9000-00429 11851 14.4V NiCd Battery
 P/N 9000-00431 11841 120V Battery Charger



ES750 Cable Cutter

- Cuts 500 kcmil copper cable in less than 8 seconds
- Approximately 20 cuts in 750 kcmil per battery charge
- Includes a one hour battery charger, battery, and molded carrying case

P/N 9700-21736 ES750-11 120 Volt Charger
 P/N 9700-37486 ES750-22 230 Volt Charger
 P/N 9000-45378 45378 12V NiCd Battery
 P/N 9000-00433 45379 120V Charger only
 P/N 9000-00434 45382 230V Charger only



Replacement Batteries & Chargers for Gator "L" Series Tools

P/N 9702-16519 52176 18 V 3.0 Ah Li-ion battery (for all pistol grip style and EK425L tools)
 P/N 9702-16794 52177 18 V 1.5 Ah Li-ion battery (for all in line style tools)
 P/N 9702-16795 52178 120V Charger
 P/N 9702-16796 52180 12V Charger

USA: 1-877-GO ALTEC
(1-877-462-5832)

www.alteconnect.com

GREENLEE BATTERY POWERED TOOLS



Professional Multi-Purpose Tools

Gator® ECCXL L-Series 6-Ton Multi-Purpose Tool

- 18V Lithium-Ion battery provides more cycle times and faster cycles
- LED work light illuminates dark work areas
- Uses a variety of easily interchanged cutting blades, crimping die adapters, and a knock-out punch adapter
- One trigger controls all tool functions, ram automatically retracts when crimp is complete
- Over-molded tacky grip areas make gripping the tool easier and more comfortable
- 6 ton crimping force, Flip-style crimping head opens easily and rotates 350°
- Uses Greenlee K22 dies and industry "W" dies
- Includes two 18V 3.0 Ah batteries

P/N 9702-21781 Greenlee ECCXL11, 120-volt charger

P/N 9702-21783 Greenlee ECCXL12, 12-volt charger

Multi-Purpose Tool Accessories:

P/N 9000-07033 Greenlee UAK Adapter for Kearney "O", T&B "6 Ton", & Blackburn "OD" dies

P/N 9000-07035 Greenlee UAW Adapter for Burndy "W" and Panduit "CD-2001" dies

P/N 9000-07036 Greenlee UC40 Cutter Blades AL & CU 1 1/2"

P/N 9700-04962 Greenlee UCACSR Cutter blades for ACSR & guy strand



Gator® ETS12L One-Time Lock Cutters

- Designed to cut disposable locks container seals, and small diameter bolts
- Light weight in-line style tool is easy to maneuver
- Cutter head rotates 3500 for use in tight locations
- Ram retracts automatically when cut is complete
- Two 18V 1.5 Ah Li-Ion batteries, battery charger, and molded carrying case included

P/N 9701-55209 ETS12L11 120 Volt Charger

P/N 9701-55210 ETS12L12 12 Volt Charger

Gator® Plus ESG45GL11 ACSR Cutters



ESG45L

- Designed specifically to cut ACSR, guy strand including EHS, and ground rod
- Flip-top style cutting head is the most durable on the market
- Includes a 120V one hour battery charger, steel carrying case, and two batteries
- Also available with 12V or 230V chargers

P/N 9700-12920 ESG45L11 Features 120 Volt Charger

P/N 9702-46250 ESG45L12 Features 12 Volt Charger

Gator® ESC105 Cable Cutters

- Large scissor style blades easily fit cables up to 4" diameter
- Side hand enhances operator control
- Cutting head rotates 350° for making tight cuts
- Cuts copper, aluminum, and steel-armored cables
- "Picks up", cuts cables that are lying on flat surfaces
- Two speed pump advances the ram quickly to start the cut; retraction stop allows the operator to stop the ram and to make subsequent cut cycle times faster
- Blades automatically open when the cut is complete
- Two batteries, battery charger, side handle, and steel carrying case included

P/N 9702-16799 ESC10511 Features 120 Volt Charger

P/N 9702-16800 ESC10512 Features 12 Volt Charger



ESC105

POWER TOOLS
BATTERY POWERED TOOLS

USA: 1-877-GO ALTEC
(1-877-462-5832)

www.alteconnect.com

**GATOR[®]
ESG105LU**
Battery Powered
Cable Cutter

**GUILLOTINE
CUTTING HEADS**

**Guillotine Cutting
Head Provides
Increased:**

- Output Force
- Cable Capacities
- Safety

Platform Versatility

- Precision blades provide *clean cuts* every time.
- Dual position handles for *easy operation* and transport.
- Lightweight, compact design
- *for professional linemen.*

Gator[®] ESC85 Cable Cutters

- Cutting large diameter copper and aluminum cables up to 3-1/4" is easy with the ESC85L
- The scissor style blades can pick cable up off of a floor and the included assist handle makes the tool easy to control
- Scissor style blades are easy to fit around cables and cutting head rotates 360° for making cuts in tight locations
- Side handle enhances operator control
- Designed for communications and underground power cable cutting
- Includes one-hour battery charger, steel carrying case, two batteries



P/N 9700-71691 ESC85L11 Features 120 Volt charger
 P/N 9700-71698 ESC85L12 Features 12 Volt charger
 P/N 9700-70123 07063 12V NiCd Battery only
 P/N 9000-30460 03046 120V Charger only

18V Lithium-Ion GATOR[®]

- Cut up to 4-1/8" diameter underground power and communications cables.
- Ergonomic design with forward positioned handle for improved center of gravity.
- Retraction stop saves time when making multiple cuts on long cables.

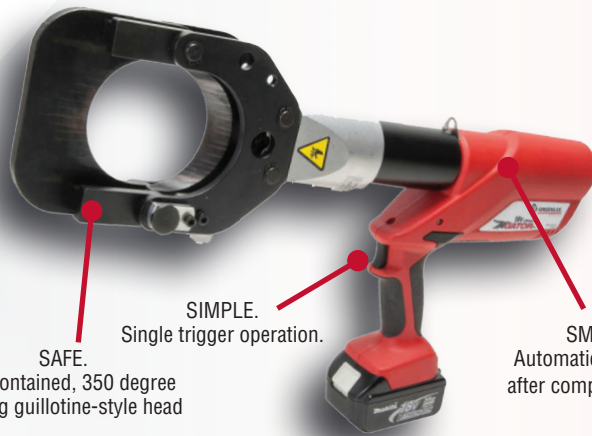

SAFE.
Self-contained, 350 degree rotating guillotine-style head

SIMPLE.
Single trigger operation.

SMART.
Automatic retraction after completed cycle.

Cable Cutters & Accessories:

9704-76279	ESG105LU11	120V Charger
9704-76287	ESG105LU12	12V Charger
9704-76299	ESG105LU120	120V AC Adapter
9704-76301	ESG105LUB	Bare Tool
9704-00346	25766	Adapter, Charger, 18V Li to 12V Ni
9702-16519	52176	Battery, 18V Li Ion 3.0 Ah
9702-16795	52178	Charger, Battery 120V
9702-39618	52179	Charger, Battery 230V
9702-16796	52180	Charger, Battery 12V
9702-88397	EAC1812	Adapter, AC - 120V to 18V
9704-00352	EAC18230	Adapter, AC - 230V to 18V
9704-00354	HTA4GL	Remote Control
9704-00355	TG3	Shoulder Strap

Hose Assemblies:

9704-00342	01059	1/4" x 6' 3/8M x 3/8F Filled
9704-00343	01058	1/4" x 6' 3/8M x 1/4M Filled
9704-00344	05850	1/4" x 10' 3/8M x 3/8F Filled
9704-00345	17707	1/4" x 10' 3/8M x 1/4M Filled

Other:

9704-00353	EL122/32	Biodegradable Hydraulic Fluid
------------	----------	-------------------------------

BATTERY POWERED TOOLS CUTTING TOOLS SPECIFICATIONS



	ES32LU Cable Cutters	ES25 ACSR Cable Cutter	ES750 Cable Cutters	E12CCXL Multi-Purpose Tool	ETS12L One-Time Lock Cutters	ESG45L ACSR Cable Cutters	ESC105 Cable Cutters	ESC85 Cable Cutters	ESG105LU 15 Ton Cable Cutters
Kit	P/N 9703-54901 ES32LU-11 P/N 9703-54904 ES32LU-12	P/N 9000-22131 ES25	P/N 9700-21738 ES750-11 P/N 9700-37486 ES750-22	P/N 9702-21784 E12CCXL11 P/N 9702-21785 E12CCXL12	P/N 9701-55209 ETS12L11 P/N 9701-55210 ETS12L12	P/N 9700-12920 ESG45L11 P/N 9702-46250 ESG45L12	P/N 9702-16799 ESC105-11 P/N 9702-16800 ESC105-12	P/N 9700-71691 ESC85L11 P/N 9700-71698 ESC85L12	P/N 9704-76279 ESG105LU11 P/N 9704-76287 ESG105LU119 P/N 9704-76299 ESG105LU120
Batteries included with Kit	18V 3.0 Ah Li-ion	14.4 Volt, NiCd (9000-00429)	12 Volt, NiCd (9000-45378)	18V 3.0 Ah Li-ion	18V 1.5 Ah Li-ion	18V 3.0 Ah Li-ion	12V, 2.6Ah, NiMH	18V 3.0 Ah Li-ion	18V 3.0 Ah Li-ion
Charger included with Kit	P/N 9703-54901 120 Volt Charger (9000-02178) P/N 9703-54904 12 Volt Charger (9000-99493)	P/N 9000-22131 120 Volt Charger (9000-00431)	P/N 9700-21738 120 Volt Charger (9000-00433) P/N 9700-37486 230 Volt Charger (9000-00434)	P/N 9702-21784 120 Volt Charger (9702-16795) P/N 9702-21785 12 Volt Charger (9702-16796)	P/N 9000-88834 120 Volt Charger P/N 9000-88835 12 Volt Charger	P/N 9700-12920 120 Volt Charger (9702-16795) P/N 9702-46250 12 Volt Charger (9702-16796)	P/N 9702-16799 120 Volt Charger (9000-02178) P/N 9702-16800 12 Volt Charger (9000-99493)	P/N 9700-71691 120 Volt Charger (9000-02178) P/N 9700-71698 12 Volt Charger (9000-99493)	P/N 9704-76279 120 Volt Charger (9702-16795) P/N 9704-76287 12 Volt Charger (9702-16796) P/N 9704-76299 120 Volt Charger with AC Adapter (9702-16795 and 9702-88397)
Length Width Height	21.62" length 17.75" width 8" height	14 3/4" length	14 1/4" length	16.50" length - -	13 5/8" length 2-7/8" width 4-1/2" height	16 5/8" length 2 7/8" width 13" height	23.75" length - 23.75" height	21" length 2 7/8" width 15 1/4" height	23.75" Length
Weight	14.99 lbs.	7.7 lbs.	12.95 lbs.	16 lbs.	4.4 lbs.	123 lbs.	22 lbs.	6.8 lbs.	22 lbs.
Capacity	• 500 kcmil copper cable • 500 kcmil aluminum cable	• ACSR: 636 kcmil (except Egret) • Aluminum: 1500 kcmil	• 750 kcmil copper cable • 1000 kcmil aluminum cable	SPECIFICATIONS Crimping Force: 12,000 lbs. Length: 16-1/2" Width: 2-7/8" Depth: 14-1/2" Weight: 14 lbs. Battery: 18V 3.0 Ah Li-ion Est. Cycles per Charge: 300 INDUSTRIAL Copper Lugs: 8-600 Copper Splices: 8-600 Aluminum Lugs: 8-350 Aluminum Splices: 8-350 Copper "C" Taps: 12-2 Aluminum Pin Adapters: 6-1/0 GROUNDING Ground Grid Connectors: 6-3 OVERHEAD 5/8" Service Ent. Connectors: 10-1/0 .840 Service Ent. Connectors: 1/0-4/0 Aluminum "H" Taps: 6-4/0 Copper "H" Taps: 12-2 Copper Tension Splice: 6-2/0 All Aluminum Tension Splice: 6-4/0 One Piece ACSR Tension Splice: 4-1/0 Two Piece ACSR Tension Splice: 2-4/0 Aluminum Jumper Splice: 4-266.8 Stirrups: 6-4/0 Aluminum Lugs: 4-4/0 Copper Lugs: 1/0-2/0	• 1-Time Disposable Lock: 4 AWG Alumoweld • Common Bolt: 1/2" • Grade 5 Bolt: 7/16" • Grade 8 Bolt: 5/16" • Boa Lock: BL-9	• ACSR: 1590 kcmil (MCM), (Falcon 54/19) • Standard Guy Strand: 5/8" diameter (16 mm diameter) • EHS Guy Strand: 1/2" diameter (13 mm diameter) • Ground Rod: 5/8" diameter (16 mm diameter)	• Not for cutting ACSR, guy strand, or other cables with steel strands • 4" Diameter Cu & Al power cables, including soft steel armored, lead sheathed and communications cables • Charges per Battery Charge: 40 (Approximate)	• 3-3/8" maximum diameter copper, aluminum, and communications cable	• 4" diameter underground power and communications cables • Cycles per Battery Charge: 40 (Approximate)

**POWER TOOLS
BATTERY POWERED TOOLS**

**USA: 1-877-GO ALTEC
(1-877-462-5832)**

www.alteccconnect.com



**POWER TOOLS
BATTERY POWERED TOOLS**

**USA: 1-877-GO ALTEC
(1-877-462-5832)**

www.alteconnect.com

	EK425L Crimping Tool	EK425L Crimping Tool	EK622L-2 Crimping Tool	EK628L 6 Ton Crimping Tool	EK1230L Crimping Tool	EK1240L & EK1240KL Crimping Tools
Kit	9702-18574 Greenlee EK425LDO11 CJD30 Crimping Jaws 9702-18576 Greenlee EK425LDBG11 CJD3BG Crimping Jaws 9702-16517 Greenlee EK425LD11 CJD3 Crimping Jaws 9702-18578 Greenlee EK425LK11 CJK Crimping Jaws	9702-18575 Greenlee EK425LDO12 CJD30 Crimping Jaws 9702-18577 Greenlee EK425LDBG12 CJD3BG Crimping Jaws 9702-16518 Greenlee EK425LD12 CJD3 Crimping Jaws 9702-18581 Greenlee EK425LK12 CJK Crimping Jaws	9000-88833 Greenlee EK622L11 9000-03552 Greenlee EK622L112	P/N 9700-72158 EK628L11 P/N 9702-21685 EK628L12	For industry "U" style dies, jaw opening is 1.2": 9000-81833 Greenlee EK1230L11 9000-81834 Greenlee EK1230L12	For industry "U" style dies, jaw opening is 1.65": 9702-18582 Greenlee EK1240L11 9702-18584 Greenlee EK1240L12 For use with Kearney PH2 style dies: 9702-18585 Greenlee EK1240KL11 9000-81838 Greenlee EK1240KL12
Batteries included with Kit	18V 3.0 Ah Li-ion (30 minute charge time)		18V 3.0 Ah Li-ion (30 minute charge time)	18V 3.0 Ah Li-ion	18V 3.0 Ah Li-ion	18V 3.0 Ah Li-ion
Charger included with Kit	9702-16795 (52178) 120 Volt Battery Charger	9702-16796 (52179) 12 Volt Battery Charger	9000-88833 120 Volt Charger 9000-03552 12 Volt Charger	P/N 9700-72158 120 Volt Charger P/N 9702-21685 12 Volt Charger	9000-81833 120 Volt Charger 9000-81834 12 Volt Charger	9702-18582 / 9702-18585 120 Volt Charger 9702-18584 / 9000-81838 12 Volt Charger
Voltage	18V		18V	18V	18V	18V
Crimping Force	6 Ton		6 Ton	12,000 lbs.	12 Ton	12 Ton
Length Width Depth	18 1/2" length 4" (head open) width -		15-3/4" length 2-7/8" width 4-1/2" depth	18 1/2" length 2-7/8" width 4 1/2" depth	14-1/2" length 2-7/8" width 12" depth	16-1/4" length 2-7/8" width 12 1/2" depth
Weight	6.8 lbs.		6-1/2 lbs.	6 lbs.	15.5 lbs.	15 lbs.
Est. Cycles/Charge	325		100	150	60	90
INDUSTRIAL CRIMPING TOOL CAPACITIES						
Copper Lugs	-	-	8-600	8-600	8-750	8-750
Copper Splices	-	-	8-600	8-600	8-400	8-750
Aluminum Lugs	-	-	8-350	8-350	8-750	8-750
Aluminum Splices	-	-	8-350	8-350	8-400	8-750
Copper "C" Taps	-	-	12-2	-	12-400	12-400
Aluminum "H" Taps	-	-	-	-	6-500	6-500
Aluminum Pin	-	-	6-1/0	-	6-500	6-750
GROUNDING CRIMPING TOOL CAPACITIES						
Ground Grid	-	-	6-3	-	6-500	6-500
Connectors	-	-	-	-	6-500	6-500
Copper "E" Taps	-	-	-	-	-	-
OVERHEAD CRIMPING TOOL CAPACITIES						
5/8" Service Entrance Connectors	10-1/0 AWG	-	10-1/0 AWG	-	10-1/0	10-1/0
.840 Service Entrance Connectors	1/0-4/0 AWG	-	1/0-4/0 AWG	-	1/0-4/0	1/0-4/0
Aluminum "H" Taps	6-4/0 AWG	-	6-4/0 AWG	-	6-500	6-500
Copper "H" Taps	10-2 AWG	-	12-2 AWG	-	12-4/0	12-4/0
Copper Tension Splice	6-2/0 AWG	-	6-2/0 AWG	-	6-500	6-500
All Aluminum Tension Splice	6-4/0 AWG	-	6-4/0 AWG	-	6-587.5	6-587.5
One Piece ACSR Tension Splice	4-1/0 AWG	-	4-1/0 AWG	-	4-556.5	4-556.5
Two Piece ACSR Tension Splice	2 AWG-477 kcmil	-	2 - 4/0	-	2-556.5	2-556.5
Aluminum Jumper Splice	4 AWG-266.8 kcmil	-	2 AWG-266.8 kcmil	-	4-556.5	4-556.5
Stirrups	2-4/0 AWG	-	6-4/0 AWG	-	6-500	6-500
Aluminum Lugs	8 AWG-500 kcmil	-	4-4/0	-	4-556.5	4-556.5
Copper Lugs	8-4/0 AWG	-	1/0-2/0	-	1/0-500	1/0-500



EK06ATL

EK06FTL

**EK06ATL /EK06FTL
L-Series Quad-Point
Crimping Tool**

**EK12IDL Dieless
Crimping Tool**

**EK1550L
15 Ton
Crimping Tool**

**EK1550FTLU
15 Ton Crimping Tool**

**ECCXL 6 Ton
Multi-Purpose
Tool**

	EK06ATL /EK06FTL L-Series Quad-Point Crimping Tool	EK12IDL Dieless Crimping Tool	EK1550L 15 Ton Crimping Tool	EK1550FTLU 15 Ton Crimping Tool	ECCXL 6 Ton Multi-Purpose Tool
Kit	P/N 9000-81829 EK06ATL11 P/N 9000-81830 EK06ATL12 P/N 9000-88834 EK06FTL11 P/N 9000-88835 EK06FTL12	P/N 9701-10712 EK12IDL11 P/N 9701-10715 EK12IDL12	P/N 9702-16797 EK1550L11 P/N 9702-16798 EK1550L12	9704-00366 Greenlee EK1550FTLU11 Tool with 120 Volt Charger 9704-00367 Greenlee EK1550FTLU12 Tool with 12 Volt Charger 9704-00369 Greenlee EK1550FTLU120 Tool with 120 Volt AC Adapter	P/N 9702-21781 ECCXL11 P/N 9702-21783 ECCXL12
Batteries included with Kit	18V 3.0 Ah Li-ion (30 minute charge time)	18V 3.0 Ah Li-ion	18V 3.0 Ah Li-ion	18V 3.0 Ah Li-ion	18V 3.0 Ah Li-ion
Charger included with Kit	P/N 9000-81829 120 Volt Charger P/N 9000-81830 12 Volt Charger P/N 9000-88834 120 Volt Charger P/N 9000-88835 12 Volt Charger	P/N 9701-10712 120 Volt Charger P/N 9701-10715 12 Volt Charger	P/N 9702-16797 120 Volt Charger (9000-02178) P/N 9702-16798 12 Volt Charger (9000-99493)	P/N 9702-16795 120 Volt Charger P/N 9702-16796 12 Volt Charger P/N 9704-00369 120 Volt Charger	P/N 9702-21781 120 Volt Charger P/N 9702-21783 12 Volt Charger
Voltage	18V	18V	18V	18V	18V
Crimping Force	12,400 lbs.	24,000 lbs.	30,000 lbs.	30,000 lbs.	12,000 lbs.
Length Width Depth	14" length 2-7/8" width 14" depth	16 1/2" length 2-7/8" width 14 1/2" depth	19 5/8" length 2 7/8" width 15" height	13 1/2" length 3" width 18 1/2" depth	16 1/2" length 2-7/8" width 14 1/2" depth
Weight	12 lbs.	15 lbs.	19 lbs.	16.3 lbs.	14 lbs.
Est. Cycles/Charge	100	90	50		300

INDUSTRIAL CRIMPING TOOL CAPACITIES

Copper Lugs	4-750	4-1000	8-1000	8-1500	8-600
Copper Splices	4-400	4-1000	8-1000	8-1500	8-600
Aluminum Lugs	6-750	6-1000	8-1000	8-1250	8-350
Aluminum Splices	6-750	6-1000	8-1000	8-1250	8-350
Copper "C" Taps	-	-	-	-	12-2
Aluminum "H" Taps	-	-	-	-	-
Aluminum Pin	-	-	-	-	6-1/0

GROUNDING CRIMPING TOOL CAPACITIES

Ground Grid	-	-	-	-	6-3
Connectors	-	-	-	-	-
Copper "E" Taps	-	-	-	-	-

OVERHEAD CRIMPING TOOL CAPACITIES

5/8" Service Entrance Connectors	8-1/0 AWG	-	-	-	10-1/0 AWG
.840 Service Entrance Connectors	4-350	-	-	-	1/0-4/0
Aluminum "H" Taps	-	-	-	-	6-4/0
Copper "H" Taps	-	-	-	-	12-2
Copper Tension Splice	6-4/0 AWG	-	-	-	6-4/0 AWG
All Aluminum Tension Splice	-	-	-	-	6-4/0
One Piece ACSR Tension Splice	4-477	-	-	-	4-1/0
Two Piece ACSR Tension Splice	-	-	-	-	2-4/0
Aluminum Jumper Splice	-	-	-	-	4-266.8
Stirrups	-	-	-	-	6-4/0
Aluminum Lugs	-	-	-	-	4-4/0
Copper Lugs	-	-	-	-	1/0-2/0

POWER TOOLS
BATTERY POWERED TOOLS

USA: 1-877-GO ALTEC
(1-877-462-5832)

www.alteccconnect.com



BURNDY is the only tool manufacturer that offers and supports tools on both Lithium-Ion and Nickel Metal Hydride platforms. Speak to your account manager to see which battery platform is most suitable for your needs. All PATRIOT® battery powered tools utilize the BURNDY INFINITY DRIVE™ transmission that has a lifetime warranty.

**POWER TOOLS
BATTERY POWERED TOOLS**

**USA: 1-877-GO ALTEC
(1-877-462-5832)**

www.alteconnect.com

PATRIOT® PATMD-LI SERIES

6 Ton, 18 Volt Lithium-ion IN-LINE® Crimping Tool



- 30 minute charger controls current, voltage and temperature to maximize battery life
- Interchangeable scissor-action crimp jaws allow for easier access in tight spaces
- Uses standard BURNDY® "W" and "X" dies
- Ergonomically balanced tool design eases operator fatigue
- Trigger-lock button to prevent accidental operation
- Large over-molded grip handle allows easier operation with gloves
- Comes with two (2) batteries, charger and tool bag and lanyard

P/N 9703-21846	PATMD6-LI
P/N 9703-58637	PATMD66-LI
P/N 9703-36938	PATMD68-LI
P/N 9703-89705	PATMD6K-LI
P/N 9704-92886	PATMD6-LIKIT1
P/N 9704-92887	PATMD66-LIKIT1
P/N 9704-92888	PATMD68-LIKIT1
P/N 9704-92889	PATMD6-LIWCJ
P/N 9704-92890	PATMD66-LIWCJ
P/N 9704-92891	PATMD68-LIWCJ

PATRIOT® PAT500SJ-LI SERIES

6 Ton, 18 Volt Lithium-ion Crimping Tool

- 30 minute charger controls current, voltage and temperature to maximize battery life
- Interchangeable scissor-action crimp jaws allow for easier access in tight spaces
- Ergonomically balanced tool design eases operator fatigue
- Large over-molded grip handle allows easier operation with gloves
- Comes with two (2) batteries, charger and tool bag and lanyard
- Uses standard BURNDY® "W" and "X" dies

P/N 9706-37170	PAT500SJ6-LI	Tool with D3 & BG Die Grooves
P/N 9706-37171	PAT500SJ66-LI	Tool with D3 Die Groove (Snub Nose)
P/N 9706-37172	PAT500SJ68-LI	Tool with D3 & O Die Grooves
P/N 9706-37173	PAT500SJ6-LIKIT1	Cutter Jaw, Crimp Jaw (D3 & BG Grooves), Hard Shell Case
P/N 9706-37174	PAT500SJ66-LIKIT1	Cutter Jaw, Crimp Jaw (D3 Groove), Hard Shell Case
P/N 9706-37175	PAT500SJ68-LIKIT1	Cutter Jaw, Crimp Jaw (D3 & O Grooves), Hard Shell Case

CRIMPING DIES, DIE KITS, DIE STORAGE

INSTALLATION DIES

"W" and "X" style dies are designed for use with all styles of MD6 and MD7 series of tools, the OUR840 tool, and the PAT500SJ Series
"U" dies are designed for use with all styles 35, 39 and 750 series of tools; also for use with the PUADP-1 adapter with the 46 series of tools
"P" dies are designed for use with all styles of the 46 series of tools

There are so many dies that we cannot list them all here! For more complete information, please contact Altec at 1-877-GO ALTEC (1-877-462-5832).



DIE KITS

P/N 9702-16399	UDIEKITAL
15 "U" die sets and case #6 AWG - 750 kcmil AL	
P/N 9702-16400	UDIEKITCU
15 "U" die sets and case #6 AWG - 750 kcmil CU	
P/N 9702-16401	UDIEKITHYGRD
8 "U" die sets and case for use on BURNDY® HYGROUND® compression grounding system	
P/N 9706-37133	WDIEKITCU
Copper W-Die Kit for #8 AWG - 500 kcmil	
P/N 9706-37134	WDIEKITAL
Aluminum W-Die Kit for #8 AWG - 350 kcmil	

DIE STORAGE (DIES NOT INCLUDED)

P/N 9000-96183	WDIETREE
Innovative "W" die holder for 6 "W" or "X" die sets	
P/N 9000-04946	CASEWDIES
Compact die case to hold 12 "W" or "X" die sets	
P/N 9000-29291	PT29291
Metal die case to hold 15 "U" die sets	



Cutter Die

P/N 9700-15446 W28K
Use with MD6/MD7 and PAT500SJ series of tools to cut conductor range #4 - 4/0 ACSR, AL or CU



BATTERY, CHARGERS, CUTTING DIE, JAW ASSEMBLIES

Accessories suitable for use with the PATMD6-LI Series

P/N 9702-16795	PATCHGRLLI	120V-AC Battery Charger
P/N 9702-16796	PATCHGRLLIDC	12/24V-DC Battery Charger
P/N 9702-16519	BAT18VLI	Extra Lithium-Ion Battery
P/N 9703-89707	TOOLBAGMDLI	Replacement Tool Bag Only
P/N 9702-35367	PATJAWSMD6	Jaw Assembly with D3 & BG
P/N 9703-90494	PATJAWSMD66	Jaw Assembly with D3 only (Snub Nose)
		Jaw Assembly with D3 & O
P/N 9702-03838	PATJAWSMD68	Jaw Assembly KEARNEY™ O Only
P/N 9703-89708	PATJAWSMD6K	Adapter to use BURNDY® W & X Dies (for use with PATMD6KLI or PATJAWSMD6K)
P/N 9703-89709	KWADP	Cutter Die Set for Cutting #4-4/0 Copper, Aluminum & ACSR
P/N 9703-66495	W28K	

Tool with D3 & BG Die Grooves
Tool with Only D3 Die Groove (Snub Nose)
Tool with D3 & O Die Grooves
Tool Accepts KEARNEY™ O Dies & BURNDY® W & X (KWADP req'd)
Cutter Jaw, Crimp Jaw (D3 & BG Grooves), Hard Shell Case
Cutter Jaw, Crimp Jaw (D3 Groove), Hard Shell Case
Cutter Jaw, Crimp Jaw (D3 & O Grooves), Hard Shell Case
Cutter Jaw, Crimp Jaw (D3 & BG Grooves), Soft Case
Cutter Jaw, Crimp Jaw (D3 Groove), Soft Case
Cutter Jaw, Crimp Jaw (D3 & O Grooves), Soft Case

THE BURNDY® ENGINEERED SYSTEM

BURNDY® coordinating connectors, dies, and installation tools are designed to work together and engineered to meet stringent, accepted quality standards.



PATRIOT® PAT46LWS-LI "OPEN" SERIES 15-Ton, 18 Volt Li-Ion Crimping Tool



- New light weight design
- Designed to terminate BURNDY® terminals and splices
- Provides 15-tons of output force with 2" jaw opening
- Redesigned field proven electronics
- Overmolded ergonomic handle on Li-ion version

- Open crimp head with 355° head rotation
- Uses BURNDY® "P" and "U" style dies (with PUADP-1 Adapter)

P/N 9706-37178 PAT46LWS-LI
P/N 9706-37179 PAT46CLWS-LI With Covered Head

PATRIOT® PAT750-LI 12-Ton 18 Volt Li-ion Crimping Tool



- True one-handed operation for advance, retract and hold
- Refined hydraulic system for ultra performance, speed and reliability
- Ergonomically balanced tool design
- Conductor Range: #12-750 kcmil
- State of the art crimping head design, 360 degree head rotation lets user get into tight areas more easily

- Includes carry case, tool, 2 batteries, charger and lanyard
- Uses BURNDY® "U" style dies

P/N 9702-98014 PAT750-LI

PATRIOT® PATHCC10ACSR-18V 18 Volt Ni-MH Cutting Tool



- C-shaped cutter head with large opening enables easy "scoop and cut" method with no need to open or close a latch
- 355° head rotation
- Retractable assist handle for easy maneuvering into correct cutting position
- Includes one (1) ACSR

blade set capable of cutting up to 1590 kcmil (Falcon)

- Other compatible blades are available; HCCCUAL cuts up to 1.5" O.D. copper or aluminum; HCCGUY cuts up to 9/16" EHS Guy Strand; HCCSOL for rebar up to 1/2" and ground rod up to 5/8"
- Includes carry case, tool, 2 batteries, charger, lanyard, and ACSR cutting blade

P/N 9706-37176 PATHCC10-18V Tool with All 4 Blade Sets (HCCACSR, HCCGUY, HCCSOL, HCCCUAL)

P/N 9703-58645 PATHCC10ACSR-18V Tool with ACSR (HCCACSR) Blade Set

P/N 9703-58652 HCCCUAL Blade Set Only

P/N 9703-58660 HCCGUY Blade Set Only

P/N 9706-37177 HCCSOL Blade Set Only

PATRIOT® PAT46LW-LI "LATCH" SERIES 15-Ton, 18 Volt Li-Ion Crimping Tool



- New light weight design
- Designed to terminate BURNDY® terminals and splices
- Redesigned field proven electronics
- 15-tons of output force with 2" jaw opening
- Overmolded ergonomic handle on Li-ion version
- Rugged forged latching crimp head with 355° head rotation
- Uses BURNDY® "P" and "U" style dies (with PUADP-1 Adapter)

P/N 9706-37180 PAT46LW-LI

PATRIOT® PATCUT2156-LI 12-Ton 18 Volt Li-ion Crimping Tool



- A versatile battery powered latch cutter designed to cut a variety of different cable types and materials
- Specialized hardened steel cutting blades provide superior cutting performance
- Cuts up to 2" diameter CU/AL, 2156 ACSR (also cuts some 2515 sizes), 3/4" Ground Rod, 5/8" Rebar, 9/16" EHS Guy Wire
- Ergonomic pistol style tool design for ease of one-handed cutting

P/N 9706-37181 PATCUT2156-LI Distribution
P/N 9706-37182 PATCUT2156T-LI Transmission

PATRIOT® PATCUT129-LI 18 Volt Li-ion Cable Cutter



- Hydraulic self-contained cutter with high-speed pump design completes tough cuts faster
- Specialized latch-head design for interference-free closure for mid-span cuts
- 180° head rotation
- Mechanical ram release
- Versatile head positioning allows user to get into tight areas more easily
- Cuts up to 1113 ACSR, 1/2" Std Guy Strand, 5/8" Soft Steel Bolts, 1/2" Rebar, 5/8" Ground Rod
- Includes carry case, tool, 2 batteries, charger and lanyard

P/N 9702-98011 PATCUT129-LI

Milwaukee 12 Volt

BATTERY-POWERED TOOLS

Nothing But HEAVY DUTY®

POWER TOOLS
BATTERY POWERED TOOLS

USA: 1-877-GO ALTEC
(1-877-462-5832)

www.alteconnect.com

M12™ Cordless Ratchet Kit

- Compact Low-Profile Head Design: 3/4" head for extremely tight spaces
- Excellent for tight spots, switch gear and mounted transformers
- Powerful 12V Motor: Delivers up to 35 ft-lbs of torque
- Superior Fastening Speed: 250 RPM
- Variable Speed Metal Trigger: Greater control and durability
- On Board Fuel Gauge: Displays remaining run-time
- Built-in LED Light: Illuminates work area and tight dark spaces
- Re-inforced steel housing for added durability and strong cranking forces
- Kit includes (1) M12™ Ratchet, (1) M12 RED LITHIUM™ Battery, 3/8" to 1/4" Adapter, Charger, Case

P/N 9703-51244	2457-21	Kit	Features 3/8" Ratchet (shown far right)
P/N 9703-51837	2457-20	Bare Tool Only	Features 3/8" Ratchet
P/N 9703-51273	2456-21	Kit	Features 1/4" Ratchet (shown right)
P/N 9703-51842	2456-20	Bare Tool Only	Features 1/4" Ratchet



NEW
Technology

M12™ Cable Cutter

- For copper and aluminum only
- LED Light - illuminates work area in boxes
- Compact front end with open Jaws - Go straight to the cable in panels without long handles, looping or ratcheting
- Auto Release Lever - Provides the ability to cut, reload and quickly repeat
- 600 MCM CU/750 MCM AL Capacity - Powerful Jaws cut effortlessly through large cable
- Superior Cut Quality - Milwaukee designed blade geometry delivers a flat, round and installation ready cut
- Outstanding Run-time - Redlithium™ Technology deliver up to 150 cut of 500 mcm CU per charge
- 2 Speed Gear Box - Delivers power for large cable, and speed for more frequent sizes

P/N 9703-55528	2472-21XC	Kit
P/N 9703-55530	2472-20	Bare Tool Only

M12™ Cordless Sub-Compact Band Saw

- The most compact portable band saw on the market today
- Only 6.75 lbs, ideal for one-handed or overhead use and 12" length, ideal for portability
- Cuts through 3/4" EMT in only 3 seconds, delivers up to 150 cuts per charge with the included M12™ REDLITHIUM XC High Capacity battery
- 1-5/8" x 1-5/8" cut capacity and low vibration; performs clean cuts on the most common small diameter metal cutting applications
- Dual-latching lower guard covers area under the blade, meets OSHA requirements for one-handed use
- Features a variable speed trigger and LED light (highlights the cut)
- Blades are 18 TPI and feature Matrix II high speed steel teeth backed by Alloy

P/N 9703-63180	2429-21XC	Kit
P/N 9703-63181	2429-20	Bare Tool Only
P/N 9703-63182	48-39-0572	3-Pack 27" Length Accessory Blades; the ONLY blade that can be used with this saw



18 VOLT BATTERY-POWERED TOOLS

Nothing But HEAVY DUTY®

M18 FUEL™ (BRUSHLESS MOTOR) COMPACT HAMMER DRILL

Milwaukee® POWERSTATE™ Brushless Motor

- Powerstate brushless motor adds 10X more durability (runs more efficiently and therefore cooler)
- 25% more power (725 inch/lbs of torque)
- 50% more run time (more efficient motor increases run time)

REDLINK PLUS™ Intelligence

- Red link plus electronics to monitor and control the power provided by the battery
- Kit includes (1) M18™ Fuel Compact Hammer Drill, (1) (2) M18™ XC High Capacity LITHIUM-ION Batteries, (1) Charger, Carrying Case

P/N 9703-55515	2604-22	Kit
P/N 9703-55516	2604-20	Bare Tool Only



NEW



18 VOLT

BATTERY-POWERED TOOLS

Nothing But HEAVY DUTY®



M18™ Cordless 1/2" Hammer-Drill / Driver Kit

- 4-pole frameless motor delivers 550 in-lbs of peak torque, 0-450/0-1,700 RPM, and 29,000 BPM
- Compact & Ergonomic Design: 8 1/2" Length
- Digital Power Management: overload protection prevents damage to the tool and battery in abusive situations
- All Metal Gear Case
- All metal 1/2" single sleeve ratcheting chuck: provides maximum durability and bit retention
- Kit includes: Tool, (2) M18™ XC High Capacity RED LITHIUM™ Batteries, Charger, Kitbox

P/N 9705-52334 2607-22 Kit
P/N 9706-37326 2607-20 Bare Tool Only

M18 FUEL™ (BRUSHLESS MOTOR) 7/16" HEX UTILITY IMPACTING DRILL

This Tool's anvil offers users the ability to insert augers with 7/16" Hex Shanks and 7/16" to 1/2" adapters for use with sockets. It is commonly used by Utility Linemen as an alternative to hydraulic or gas drills.

PERFORMANCE

- 500 ft.-lbs. max fastening torque
- Greater output torque than all cordless impact wrenches

CONTROL

- Proprietary 2-Mode Drive Control™ feature offers users control in applications where maximum torque is not necessary

PRODUCTIVITY

- Up to 2 times more run-time vs. competitors

DURABILITY

- POWERSTATE™ Brushless motor lasts 3 times longer than competitive cordless Utility Impacting Drills
- Kit includes: (1) M18 FUEL™ 7/16" Hex Utility Impacting Drill (2765-20)
(2) M18™ REDLITHIUM™ XC 4.0 Extended Capacity Battery Pack (48-11-1840)
(1) M18™ & M12™ Multi-Voltage Charger (48-59-1812), (1) Carrying Case

P/N 9704-89786 2762-20: M18 FUEL™ 1/2" HTIW w/ Pin (Bare Tool Only)

P/N 9704-89798 2762-22: M18 FUEL™ 1/2" HTIW w/ Pin (Kit)

P/N 9704-89799 2763-20: M18 FUEL™ 1/2" HTIW w/ Ring (Bare Tool Only)

P/N 9704-89800 2763-22: M18 FUEL™ 1/2" HTIW w/ Ring (Kit)

P/N 9704-89801 2764-20: M18 FUEL™ 3/4" HTIW w/ Ring (Bare Tool Only)

P/N 9704-89802 2764-22: M18 FUEL™ 3/4" HTIW w/ Ring (Kit)

P/N 9704-89803 2765-20: M18 FUEL™ 7/16" Utility Drill (Bare Tool Only)

P/N 9704-89804 2765-22: M18 FUEL™ 7/16" Utility Drill (Kit)*

* This kit includes a contractor bag (no case) and ACDC Charger (not the Multi-Volt Charger)



M18™ 7/16" Hex High Torque Impact Wrench Kit

- Milwaukee® designed impact mechanism: delivers 350 ft. lbs. of torque
- Compact and light weight: 9 1/2" length and 7 lbs.
- Milwaukee® 4-Pole Frameless Motor: delivers maximum run-time
- 7/16" Hex Chuck: provides quick and easy accessory changes
- Kit includes (1) M18™ 7/16" Hex High Torque Impact Wrench, (2) M18™ XC High Capacity RED LITHIUM™ Batteries (48-11-1828), M18™ LITHIUM-ION Battery Charger (48-59-1801) this Battery charger will be upgraded to the P/N 9702-32043 (2710-20) ACDC 18V Charger; Kitbox

P/N 9701-89942 2665-22 Kit with AC/DC Charger

P/N 9702-35487 2665-20 Bare Tool Only

M18™ 1/2" High Torque Impact Wrench Pin Detent Kit

- Milwaukee® designed impact mechanism: delivers 450 ft.-lbs. of torque
- Compact and light weight: 8 7/8" length and 5.2 lbs.
- Milwaukee® 4-Pole Frameless Motor: delivers maximum run-time
- 1/2" Anvil with Pin Detent: Provides maximum socket retention
- Kit includes (1) 2662-22 M18™ 1/2" High Torque Impact Wrench with Pin Detent Kit, (2) M18™ XC High Capacity RED LITHIUM™ Batteries (48-11-1828), Charger (48-59-1801), Kitbox

P/N 9701-89941 2662-22 Kit

P/N 9703-51811 2662-20 Bare Tool Only



NEW



POWER TOOLS
BATTERY POWERED TOOLS

USA: 1-877-GO ALTEC
(1-877-462-5832)

www.alteconnect.com



18 VOLT

BATTERY-POWERED TOOLS

Nothing But HEAVY DUTY®

POWER TOOLS
BATTERY POWERED TOOLS

USA: 1-877-GO ALTEC
(1-877-462-5832)

www.alteconnect.com



M18 FUEL™ (Brushless Motor) 1/4" Hex Impact Driver Kit

Milwaukee® POWERSTATE™ Brushless Motor

- Runs cooler, lasts longer and delivers up to 55% faster application speed
- REDLINK PLUS™ Intelligence
- Allows the operator to choose between 3 fastening modes with Milwaukee's proprietary DRIVE CONTROL™ feature REDLITHIUM™ XC 4.0 Battery Pack
- The most durable pack on the market and provides up to 50% more run time

DRIVE CONTROL™

• Three fastening modes provide variable power and speed for precision work and heavy duty applications

• Kits include (1) M18 FUEL™ 1/4" Hex Impact Driver (2653-20) (2) M18™ REDLITHIUM™ 2.0 Compact Battery Pack (48-11-1820) (1) M18™ & M12™ Multi-Voltage Charger (48-59-1812) (1) Belt Clip (1) Carrying Case

P/N 9703-98459 2653-22 Kit

P/N 9705-28222 2653-20 Bare Tool Only

M18™ 2-Speed 1/4" Hex Impact Driver Kit

- Milwaukee® 4-Pole Frameless Motor: Features a robust design for longer life, more power and more runtime than any brushed competitor
- Milwaukee® designed Impact Mechanism: Delivers maximum power and application speed for greater efficiency on the job
- REDLINK™ Intelligence: Provides optimized performance and overload protection using total system communication between tool, battery and charger
- Proprietary 2-Mode DRIVE CONTROL™: Two speed / torque modes allow class-leading control for greater application versatility
- 1/4" Hex Quick-Connect Chuck
- REDLITHIUM™ Battery Technology: Superior pack construction, electronics, and performance deliver more work per charge and more work over pack life than any battery on the market
- Includes (1) M18 2-Speed 1/4" Hex Impact Driver (2657-20), (2) M18™ REDLITHIUM™ XC Extended Capacity Battery (48-11-1828) (1) M18™ & M12™ Multi-Voltage Charger (48-59-1812), (1) Belt Clip (1) Carrying Case

P/N 9705-84698 2657-22

P/N 9705-84699 2657-20 Bare Tool Only

M18 Fuel™ (Brushless Motor) 1/2" Impact Wrench w/Pin

- Delivers a best-in-class 210 ft-lbs. and 2,520 in-lbs of torque in a compact design
- The Milwaukee® POWERSTATE™ Brushless Motor provides increased efficiency, lasts longer and delivers maximum power
- REDLITHIUM™ XC 4.0 Battery Pack is the most durable pack on the market and provides up to 2X more run time
- REDLINK PLUS™ Electronic Intelligence allows the operator to choose from 3 fastening modes with Milwaukee's proprietary DRIVE CONTROL™ feature
- Utilizes a pin detent design for maximum socket retention
- Kit includes: (1) M18 FUEL™ 1/2" Impact Wrench w/ Pin (2655-20), (1) M18™ & M12™ Multi-Voltage Charger (48-59-1812), (2) M18™ REDLITHIUM™ XC 4.0 Extended Capacity Battery Pack (48-11-1840), (1) Belt Clip, (1) Case

P/N 9704-44188 2655-22 Kit with AC/DC Charger

P/N 9704-44189 2655-20 Bare Tool Only



M18™ Cordless LITHIUM-ION

1/2" Compact Impact Wrench with Pin Detent Kit

- Milwaukee M18™ XC High Capacity RED LITHIUM™ battery features Digital Power Management with Overload Protection and a Temperature Management System to provide maximum tool life
- Weighing in at only 4.1 lbs. and measuring 5-3/4"; reduces fatigue without sacrificing power
- 183 ft-lbs. of torque
- Milwaukee® Designed Impact Mechanism: maximum application speed
- Milwaukee® 4-Pole Frameless Motor: maximum efficiency and run-time
- 1/2" Detent Pin: provides positive bit retention
- Built-In LED Light: illuminates work surface
- Includes (1) 2652 M18™ Cordless LITHIUM-ION 1/2" Compact Impact Wrench w/Pin Detent, (2) M18™ XC High Capacity RED LITHIUM™ Batteries, Charger, Carrying Case

P/N 9702-30078 2659-22 Kit

P/N 9703-02770 2659-20 Bare Tool Only



18 VOLT

BATTERY-POWERED TOOLS

Nothing But HEAVY DUTY®

M18™ Cordless LITHIUM-ION 3/8" Compact Impact Wrench with Ring Kit

- Powered by RED LITHIUM™ technology
- Weighing in at only 4.1lbs and measuring 5-3/4"; reduces fatigue without sacrificing power
- 166 ft.-lbs. of torque
- Milwaukee® Designed Impact Mechanism: maximum application speed
- Milwaukee® 4-Pole Frameless Motor: maximum efficiency and run-time
- 3/8" Friction Ring: allows quick socket changes
- Built-In LED Light: illuminates work surface
- Includes (1) 2651 M18™ Cordless LITHIUM-ION 3/8" Compact Impact Wrench w/Ring, (2) M18™ XC High Capacity RED LITHIUM™ Batteries, Charger, Carrying Case

P/N 9706-37327 2658-22 Kit

P/N 9706-37328 2658-20 Bare Tool Only



M18 FUEL™ (BRUSHLESS MOTOR) Sawzall® RECIPROCATING SAW KIT

LONGEST RUN TIME

- Up to 2X more cuts per charge than competitive cordless reciprocating saws

FASTEST CUTTING

- Up to 30% faster cutting in key applications
- Outperforms all competitive 18V cordless reciprocating saws
- Reduced vibration provides faster starts in metal stock

MOST DURABLE

- Up to 5X longer tool life than competitive reciprocating saws
- Patented gear-protecting clutch
- Enhanced water and dust protection extends tool life

USER DEMANDED FEATURE SET

- Adjustable Shoe, LED Light, and Hang Hook
- Kit includes: (1) M18 FUEL™ SAWZALL® Reciprocating Saw (2720-20)
- (1) M18™ REDLITHIUM™ XC 4.0 Extended Capacity Battery Pack (48-11-1812)
- (1) M18™ & M12™ Multi-Voltage Charger (48-59-1812), (1) Blade, (1) Carrying Case

P/N 9704-76472 2720-21 Kit w/ 1 XC4.0

P/N 9704-76473 2720-22 Kit w/ 2 XC4.0

P/N 9704-76471 2720-20 Bare Tool Only

NEW



TOOL LIFE

LONGER TOOL LIFE



Milwaukee®
Makita
DeWalt

UP TO
5X
LONGER
TOOL LIFE

M18™ Lithium-Ion Sawzall® Kit

- Features a patented gear-protecting clutch, which absorbs impact
- QUIK-LOK™ blade clamp provides quick and efficient blade changes
- Variable speed trigger optimizes speed for different applications
- On-board fuel gauge displays the remaining run-time
- Offers up to 75 more cuts per charge; designed to cut up to 30% faster with less vibration
- P/N 9702-80717 includes (1) 2620-22 Sawzall® M18™ Cordless LITHIUM-ION Recip Saw, (2) M18™ XC High Capacity RED LITHIUM™ Batteries (48-11-1828), Charger, (1) General Purpose SAWZALL® Blade, Carrying Case
- P/N 9701-82180 includes (1) 2620-22 Sawzall® M18™ Cordless LITHIUM-ION Recip Saw, (1) M18™ XC High Capacity RED LITHIUM™ Battery (48-11-1828), Charger, (1) General Purpose SAWZALL® Blade, Carrying Case

P/N 9702-80717 2620-22 Kit with (2) Batteries

P/N 9701-82180 2620-21 Kit with (1) Battery

P/N 9702-41485 2620-20 Bare Tool Only



M18™ Cordless LITHIUM-ION 7/8" SDS Plus Rotary Hammer Kit

- Powerful Hammer Mechanism: Delivers 1.8 ft.-lbs of impact energy
- Mechanical Clutch: Protects tool when bit binds up
- AVS - Anti Vibration System: Delivers maximum comfort by minimizing vibration
- 3-Mode Operation: Rotary hammer, hammer only and rotation only for maximum versatility
- Variable Position Chisel Stop: Allows Steel to be adjusted for work in any orientation
- Kit includes (1) 2605-20 M18™ 7/8" Rotary Hammer, (2) M18™ XC High Capacity RED LITHIUM™ Battery Packs, Charger, Side Handle, Depth Rod, Carrying Case

P/N 9703-51239 2605-22 Kit

P/N 9703-51826 2605-20 Bare Tool Only



POWER TOOLS
BATTERY POWERED TOOLS

USA: 1-877-GO ALTEC
(1-877-462-5832)

www.alteconnect.com



18 VOLT

BATTERY-POWERED TOOLS

Nothing But HEAVY DUTY®

M18 FUEL™ (BRUSHLESS MOTOR) 4-1/2" / 5" GRINDER KIT

POWER TO GRIND

- World's first cordless grinder with corded performance
- Effectively grind, surface prep, and cut while existing cordless tools are perceived as cut-off tools only

PRODUCTIVITY

- 2X more run-time for increased productivity
- 100% tool-free-tool - No Wrench, No Screwdriver, No Problem
 - Tool-free accessory change to easily change "all accessories" without a wrench
 - Tool-free adjustable guard for quick guard installations and adjustments

DURABILITY

- 10X longer motor life for a lower cost of ownership
- Electronic clutch extends life of tool and prevents burn-up
- Same metal housing and gearing system as legendary high performance corded grinders

ERGONOMICS

- Extremely thin body design and Anti-vibration side handle
- Kits (P/N 9704-76478, P/N 9704-76479, P/N 9704-89784, P/N 9704-89785) include (1) M18 FUEL™ 4-1/2" / 5" Grinder, Paddle Switch No-Lock (2780-20), (1) M18™ REDLITHIUM™ XC 4.0 Extended Capacity Battery Pack (48-11-1840), (1) M18™ & M12™ Multi-Voltage Charger (48-59-1812), (1) Carrying Case, (1) Flange Nuts, (1) Wheel Guard, (1) Spanner Wrench
- P/N 9704-76477 (2780-20) includes (1) M18 FUEL™ 4-1/2" / 5" Grinder, Paddle Switch No-Lock, (1) Flange Nut, (1) Wheel Guard, (1) Spanner Wrench
- P/N 9704-76480 (2781-20) includes (1) M18 FUEL™ 4-1/2" / 5" Grinder, Slide Switch Lock-On, (1) Flange Nut, (1) Wheel Guard, (1) Spanner Wrench



P/N 9704-76480 2781-20
Slide Switch Lock-On



P/N 9704-76477 2780-20
Paddle Switch No-Lock

P/N 9704-76477 2780-20 Paddle Switch (Bare Tool Only)
 P/N 9704-76478 2780-21 Paddle Switch (Kit w/ 1XC4.0)
 P/N 9704-76479 2780-22 Paddle Switch (Kit w/ 2 XC4.0)

P/N 9704-76480 2781-20 Slide Switch (Bare Tool Only)
 P/N 9704-89784 2781-21 Slide Switch (Kit w/ 1 XC4.0)
 P/N 9704-89785 2781-22 Slide Switch (Kit w/ 2 XC4.0)

M18™ 4 1/2" Cut-Off / Grinder

- Up to 35% faster cutting speed and up to 50% more cuts on a single charge
- 3-Position Side Handle
- Debris baffles, a tool-free, burst-resistant guard; paddle switch design
- 4-pole motor delivers maximum power when cutting or grinding
- P/N 9701-98850 includes (1) 2680 4-1/2" Cut-off Grinder, (2) M18™ XC High Capacity RED LITHIUM™ Batteries, Charger, Type 1 Guard, Type 27 Guard, Type 1 Cut-Off Wheel, Spanner Wrench, Side Handle, Contractor Bag

P/N 9701-98850 2680-22 Kit
 P/N 9701-98849 2680-20 Bare Tool Only

M18™ 5 3/8" Metal Saw

- Excellent for cutting bolts, anchor rod, bus bars, cable, and guy wire
- Quick clean cuts on cable
- Depth of cut 1/8" to 2", cut is cool to touch
- Sight window
- Excellent for cutting cable and guy wire
- Kit includes (1) M18™ Metal Saw, (2) M18™ XC High Capacity LITHIUM-ION Batteries, (1) Blade, (1) Charger, Contractor Bag, and Blade Wrench

P/N 9703-42450 2682-22 Kit
 P/N 9703-61502 2682-20 Bare Tool Only

Excellent for Cutting Cable and Guide Wire!



M18 FUEL™ (BRUSHLESS MOTOR) 6-1/2" CIRCULAR SAW KIT

POWERSTATE™ Brushless Motor

- Outpowers all other 18-volt cordless circular saws and provides up to 3X longer tool life

REDLINK PLUS™ Intelligence

- The most advanced electronic system on the market maximizes performance

REDLITHIUM™ XC 4.0 Battery Pack

- Offers up to 4X more runtime, 20% more power and up to 2X more recharges than competitive batteries

- Kits include (1) M18 FUEL™ 6-1/2" Circular Saw (2730-20), (2) M18™ REDLITHIUM™ XC 4.0 Extended Capacity Battery Pack (48-11-1840), (1) M18™ & M12™ Multi-Voltage Charger (48-59-1812), (1) Blade, (1) Blade Wrench, (1) Contractor Bag



POWER TOOLS
BATTERY POWERED TOOLS

USA: 1-877-GO ALTEC
(1-877-462-5832)

www.alteconnect.com



P/N 9704-76475 2730-21 Kit with (1) Battery, (1) AC/DC Charger
 P/N 9704-76476 2730-22 Kit with (2) Batteries, (1) AC/DC Charger
 P/N 9704-76474 2730-20 Bare Tool Only

18 VOLT

BATTERY-POWERED TOOLS

Nothing But HEAVY DUTY®

M18 FUEL™ (BRUSHLESS MOTOR) CORDLESS DEEP CUT BAND SAW

- The Milwaukee® POWERSTATE™ Brushless Motor provides increased efficiency, lasts longer and delivers maximum power
- CPT™ Constant Power Technology: Maintains cut speed in the toughest applications for optimal performance
- Over 90% same parts as Milwaukee's Corded Deep Cut Band Saw
- Jobsite Armor Technology™: Proprietary composite material and crush zone barriers provide long lasting rugged protection
- REDLINK PLUS™ Intelligence: Advanced system provides optimized performance and overload protection using total system communication between tool, battery and charger
- All metal direct drive and gearing system delivers maximum tool life
- REDLITHIUM™ XC 4.0 Battery provides superior pack construction, more work per charge and more work over the life of the pack than competitive batteries
- Tool-Free locking adjustable shoe: Button actuated design allows user to quickly adjust from extended shoe to no shoe in seconds
- Industry's largest cut capacity: Versatility to cut up to 5" x 5" material in one pass and adjustable shoe allows for less tool rotation when cutting material above 5"
- LED light: Illuminates work surface for increased accuracy and productivity
- Kit includes M18 FUEL™ Deep Cut Band Saw, (2) M18™ REDLITHIUM™ XC 4.0 Extended Capacity Battery Pack, (1) M12™ & M18™ Multi-Voltage Charger, Blade, & Carrying Case

P/N 9706-37329 2729-21 Kit with (1) Battery, (1) AC/DC Charger

P/N 9706-37330 2729-22 Kit with (2) Batteries, (1) AC/DC Charger

P/N 9705-87760 2729-20 Bare Tool Only



M18™ Band Saw Kit

- 45% Lighter than Deep Cut – 10.25 Lbs. compact light weight design
- 3-1/4" Cut Capacity – cuts most common materials for cutting applications
- Single pass cut on 3" copper, 3" angle iron, 2-1/2" conduit
- Tool-Free Adjustable Material Shoe
- LED Work Light – illuminates the cut line in dark areas.
- Blade Ejection System
- Great for cutting cable, guide wire, ground rod
- Drop Resistant Pulley Guard-Engineered geometries and high impact polymer.
- Cast Aluminum Gear Case-Withstands jobsite abuse, maintains gear positioning
- Kit includes (1) M18™ Cordless Band Saw 2629-22, (2) M18™ XC High Capacity LITHIUM-ION Batteries, (1) Charger, (1) Blade, (1) Case

P/N 9702-91835 2629-22 Kit

P/N 9703-51823 2629-20 Bare Tool Only

M28™ Lithium-Ion 1/2" Drive Impact Wrench Kit

- 325 ft./lbs. of torque
- Battery fuel gauge
- Up to 2x the run time of a 18V Nicad battery
- P/N 9701-99380 is tool only, without batteries, etc.
- P/N 9701-83730 comes with two batteries, charger, case, and steel ring hangar bracket

P/N 9701-83730 0779-22 Kit

P/N 9701-99380 0779-20 Bare Tool Only

M28™ Lithium-Ion 7/16" Impact Wrench Kit

- 325 ft./lbs. of torque
- Up to 2x run-time of 18V tools
- Hanger Bracket with solid steel ring
- Magnesium Gearcase for added durability and lighter weight
- P/N 9701-87404 kit includes (1) 9701-82883 tool, (2) 9701-82989 batteries, (1) charger, and (1) 9701-83147 contractor bag

P/N 9701-87404 0799-20 KIT

Complete Kit

P/N 9701-82883 0799-20

Bare Tool Only

M28™ Cordless 1/2" Hammer-Drill Kit

- 1/2" all metal, single sleeve, ratcheting chuck with all carbide jaws
- 600 in.-lbs. of maximum torque
- Exclusive Clip-Lok™ system
- Up to 2x run-time of 18 volt tools
- Kit includes: (2) V28® LITHIUM-ION Batteries, Cordless Drill Carrying Case, Charger, Clip-Lok™ System Side Handle, No. 2 Phillips Bit

P/N 9701-82160 0726-22 Kit

P/N 9702-79136 0726-20 Bare Tool Only

327



P/N 9701-82883 Below

P/N 9701-83730 Right

POWER TOOLS
BATTERY POWERED TOOLS

USA: 1-877-GO ALTEC
(1-877-462-5832)

www.alteconnect.com



28 VOLT

BATTERY-POWERED TOOLS

Nothing But HEAVY DUTY®

POWER TOOLS
BATTERY POWERED TOOLS

USA: 1-877-GO ALTEC
(1-877-462-5832)

www.alteconnect.com



P/N 9701-82908

M28™ Lithium-Ion Sawzall® with Case

- 0-2,000/0-3,000 SPM for metal or wood cutting
- Quik-Lok™ blade clamp and gear protecting clutch for extreme durability
- Keyless shoe adjustment quickly adjusts blade
- Kit includes (1) M28™ Sawzall® Reciprocating Saw, Two Super Sawzall® Blades, (1) 28V LITHIUM-ION Battery - 48-11-2830, Charger

P/N 9701-82179 0719-22 Kit
 P/N 9702-67016 0719-20 Bare Tool Only

M28™ Lithium-Ion Grinder/Cut-Off Tool



P/N 9701-82908

- 8000 RPM no load speed
- Soft start reduces start-up torque and improves gear life
- Large spindle lock for quick wheel replacement
- Battery fuel gauge
- Kit includes Tool, V28® (1) Lithium-Ion Battery, Contractor Bag, Grinding Wheel 4 1/2" x 1/4" x 7/8" (Type 27), Cut-Off Wheel 4 1/2" x .045" x 7/8" (Type 1), Spanner Wrench

P/N 9701-82908 0725-21 Kit
 P/N 9704-66727 0725-20 Bare Tool Only
 P/N 9701-83733 49-94-4520 Grinding Wheel, 4 1/2" x 1/4" x 7/8" (Type 27)
 P/N 9701-83737 49-94-4500 Cut-Off Wheel, 4-1/2" x .045" x 7/8" (Type 1)

M28™ Compact 1" SDS Rotary Hammer Kit

- 28 Volt high power reversible motor delivers 4,700 BPM and 2.1 ft. lbs. of impact energy
- Optimal drilling range in concrete is from 3/16" to 3/4" with a 1" solid bit capacity 2 1/2" thin wall core bit capacity
- Soft-grip handle, two finger reversible trigger for comfort
- Three operating modes - hammer drill, drill only, and chipping
- Includes (1) M28™ Compact 1" SDS Rotary Hammer, (2) 28V LITHIUM-ION Batteries, Charger, Carrying Case, Side Handle, Depth Gauge

P/N 9701-82889 0756-22 Kit
 P/N 9703-51844 0756-20 Bare Tool Only



M28™ Lithium-Ion Band Saw Kit



- 4 3/4" x 4 3/4" capacity
- Worm Gear and Chain Drive
- Perfectly balanced; LED Light
- P/N 9701-83141 is 44 7/8" long, features Bi-Metal Construction and Matrix II high speed steel teeth with 8% cobalt for cutting stock 3/16" to 1/2" thick; 44 7/8" x 1/2" x .020" blades
- Includes Tool, (1) V28® Battery Pack, Carrying Case for V28™ Band Saw, Charger

P/N 9701-82887 0729-21 Band Saw Kit
 P/N 9703-52163 0729-20 Band Saw Tool Only
 P/N 9702-55662 48-39-0510 Band Saw Blade, Quantity of 1
 P/N 9701-83141 48-39-0551 3 pk. Blade 10/14 TPI



PN 9703-51244

PN 9703-51273



	3/8" Ratchet	12V 1/4" Ratchet	12V Cable Cutter	12V Band Saw	FUEL™ (Brushless Motor) Compact Hammer Drill	Hammer Drill / Driver	7/16" Impact Wrench
Kit	9703-51244 Milwaukee 2457-21	9703-51273 Milwaukee 2456-21	9703-55528 Milwaukee 2472-21XC	9703-63180 Milwaukee 2429-21XC	9703-55515 Milwaukee 2604-22	9705-52334 Milwaukee 2607-22	9701-89942 Milwaukee 2665-22
Bare Tool Only	9703-51837 Milwaukee 2457-20	9703-51842 Milwaukee 2456-20	9703-55530 Milwaukee 2472-20	9703-63181 Milwaukee 2429-20	9703-55516 Milwaukee 2604-20	9706-37326 Milwaukee 2607-20	9702-35487 Milwaukee 2665-20
Batteries included with Kit	(1) M12 RED LITHIUM™ Battery	(1) M12 RED LITHIUM™ Battery	(1) M12 RED LITHIUM™ Battery	(1) M12™ RED LITHIUM XC High Capacity battery	(2) M18™ RED LITHIUM™ XC 4.0 Extended Capacity Battery Pack (48-11-1840)	(2) M18™ XC High Capacity RED LITHIUM™ Batteries (48-11-1828)	(2) M18™ XC High Capacity RED LITHIUM™ Batteries (48-11-1828)
Charger included with Kit	30-Minute Charger	30-Minute Charger	30-Minute Charger	30-Minute Charger	(1) M18™ & M12™ Multi-Voltage Charger (48-59-1812)	M18™ LITHIUM-ION 1-Hr Battery Charger (48-59-1801)	(1) P/N 9702-32043 ACDC 18V Charger (2710-20)
Torque	35 ft.-lbs.	30 ft.-lbs.			725 in.-lbs.	525 in.-lbs.	350 ft.-lbs.
RPM	250 RPM	250 RPM			0-1,850 RPM	0-400/ 0-1,800 RPM	0-1,900 RPM
Length	10-3/4"	10-3/4"		12"	7 9/10"	7-3/4"	9 1/2"
Kit Tool Weight	1.9 lbs.	1.9 lbs.		6.75 lbs	(Ship Wt: 13.1 lbs.)	4.5 lbs.	7 lbs.
Additional Features	<ul style="list-style-type: none"> On-Board Fuel Gauge LED Light 3/8" to 1/4" Adapter Variable Speed, Metal Trigger On Board Fuel Gauge LED Light 	<ul style="list-style-type: none"> On-Board Fuel Gauge LED Light 1/4" Ball Detent Variable Speed, Metal Trigger On Board Fuel Gauge LED Light 	<ul style="list-style-type: none"> On-Board Fuel Gauge LED Light Cuts up to 600 MCM Cu and 750 Al Delivers up to 150 cuts of 500 MCM Copper per charge Auto-Release Lever Installation Ready Cut 	<ul style="list-style-type: none"> Variable speed trigger LED Light (highlights the cut) Ideal for one-handed or overhead use and ideal for portability Cuts 3/4" EMT Up to 150 cuts/charge 1-5/8" cut capacity Low vibration 	<ul style="list-style-type: none"> On-Board Fuel Gauge LED Light Variable Speed 	<ul style="list-style-type: none"> On-Board Fuel Gauge LED light Chuck Type: 1/2" Single Sleeve 	<ul style="list-style-type: none"> On-Board Fuel Gauge LED Light Anvil Type & Size: 7/16" Hex



	FUEL™ (Brushless Motor) 7/16" Hex Utility Impacting Drill	FUEL™ (Brushless Motor) 7/16" Hex Utility Impacting Drill	FUEL™ (Brushless Motor) 7/16" Hex Utility Impacting Drill	FUEL™ (Brushless Motor) 7/16" Hex Utility Impacting Drill	7/16" Impact Wrench	1/2" Impact Wrench
Kit	P/N 9704-89798 1/2" HTIW w/ Pin (Kit) Milwaukee 2763-22	P/N 9704-89800 1/2" HTIW w/ Ring (Kit) Milwaukee 2763-22	P/N 9704-89802 3/4" HTIW w/ Ring (Kit) Milwaukee 2764-22	P/N 9704-89804 7/16" Utility Drill (Kit)* Milwaukee 2765-22 * Contractor bag (no case)	9701-89942 Milwaukee 2665-22	9701-89941 Milwaukee 2662-22
Bare Tool Only	9704-89786 1/2" HTIW w/ Pin Milwaukee 2762-20	9704-89799 1/2" HTIW w/ Ring Milwaukee 2763-20	9704-89801 3/4" HTIW w/ Ring Milwaukee 2764-20	9704-89803 7/16" Utility Drill Milwaukee 2765-20	9702-35487 Milwaukee 2665-20	9703-51811 Milwaukee 2662-20
Batteries included with Kit	(2) M18™ REDLITHIUM™ XC 4.0 Extended Capacity Battery Pack (48-11-1840)	(2) M18™ REDLITHIUM™ XC 4.0 Extended Capacity Battery Pack (48-11-1840)	(2) M18™ REDLITHIUM™ XC 4.0 Extended Capacity Battery Pack (48-11-1840)	(2) M18™ REDLITHIUM™ XC 4.0 Extended Capacity Battery Pack (48-11-1840)	(2) M18™ XC High Capacity RED LITHIUM™ Batteries (48-11-1828)	(2) M18™ XC High Capacity RED LITHIUM™ Batteries (48-11-1828)
Charger included with Kit	Include (1) M18™ & M12™ Multi-Voltage Charger (48-59-1812)	Include (1) M18™ & M12™ Multi-Voltage Charger (48-59-1812)	Include (1) M18™ & M12™ Multi-Voltage Charger (48-59-1812)	P/N 9704-89804 includes (1) 2710-20 ACDC Charger	(1) P/N 9702-32043 ACDC 18V Charger (2710-20)	(1) M18™ & M12™ Multi-Voltage Charger (48-59-1812)
Torque	350 ft.-lbs (Mode 1), 600 ft.-lbs (Mode 2)	100 ft.-lbs (Mode 1), 700 ft.-lbs (Mode 2) 1,100 ft.-lbs. Nut-Busting Torque	375 ft.-lbs (Mode 1), 750 ft.-lbs (Mode 2) 1,200 ft.-lbs. Nut-Busting Torque		350 ft.-lbs	450 ft.-lbs
RPM	0-2200 RPM	0-2200 RPM	0-2200 RPM	0-2200 RPM	0-1,900 RPM	0-1,900 RPM
Length	-	-	-	-	9 1/2"	8-7/8"
Kit Tool Weight	-	-	-	-	7 lbs.	6.7 lbs.
Additional Features	<ul style="list-style-type: none"> Anvil Size/Type: 1/2"; Detent Variable Speed Trigger Greater output torque than all cordless 7/16" Hex Tools Brushless motor lasts 3 times longer than competitive cordless Utility Impacting Drills 	<ul style="list-style-type: none"> Anvil Size/Type: 1/2" Square; Friction Ring with through hole Variable Speed Trigger Greater output torque than all cordless 7/16" Hex Tools Brushless motor lasts 3 times longer than competitive cordless Utility Impacting Drills 	<ul style="list-style-type: none"> Anvil Size/Type: 3/4" Square; Friction Ring with through hole Variable Speed Trigger Greater output torque than all cordless 7/16" Hex Tools Brushless motor lasts 3 times longer than competitive cordless Utility Impacting Drills 	<ul style="list-style-type: none"> 7/16" Hex Change Variable Speed Trigger Greater output torque than all cordless 7/16" Hex Tools Brushless motor lasts 3 times longer than competitive cordless Utility Impacting Drills 	<ul style="list-style-type: none"> On-Board Fuel Gauge LED Light Anvil Type & Size: 7/16" Hex 	<ul style="list-style-type: none"> Anvil Size: 1/2" Sq. Anvil Type: Pin Detent On-Board Fuel Gauge LED Light

POWER TOOLS
BATTERY POWERED TOOLS

USA: 1-877-GO ALTEC
(1-877-462-5832)

www.alteccconnect.com



**POWER TOOLS
BATTERY POWERED TOOLS**

USA: 1-877-GO ALTEC
(1-877-462-5832)

www.alteconnect.com

	FUEL™ (Brushless Motor) 1/4" Hex Impact Driver	1/4" Hex Compact Impact Driver	FUEL™ (Brushless Motor) 1/2" Impact Wrench with Pin	1/2" Compact Impact Wrench with Pin Detent	3/8" Compact Impact Wrench with Ring	FUEL™ (Brushless Motor) SAWZALL Recip. Saw Kit	Sawzall Reciprocating Saw
Kit	9703-98459 Milwaukee 2653-22	9705-84698 Milwaukee 2657-22	9704-44188 Milwaukee 2655-22	9706-40803 Milwaukee 2659-22	9706-37327 Milwaukee 2658-22	9704-76742 Kit w/1 XC4.0 Battery Milwaukee 2720-21 9704-76473 Kit w/2 XC4.0 Batteries Milwaukee 2720-22	9701-82180 Milwaukee 2620-22
Bare Tool Only	9705-28222 Milwaukee 2653-20	9705-84699 Milwaukee 2657-20	9704-44189 Milwaukee 2655-20	9705-94727 Milwaukee 2659-20	9706-37328 Milwaukee 2658-20	9704-76471 Milwaukee 2720-20	9702-41485 Milwaukee 2620-20
Batteries included with Kit	(2) M18™ REDLITHIUM™ XC 4.0 Extended Capacity Battery Pack (48-11-1840)	(2) M18™ XC High Capacity RED LITHIUM™ Batteries (48-11-1828)	(2) M18™ REDLITHIUM™ XC 4.0 Extended Capacity Battery Pack (48-11-1840)	(2) M18™ XC High Capacity RED LITHIUM™ Batteries (48-11-1828)	(2) M18™ XC High Capacity RED LITHIUM™ Batteries (48-11-1828)	(2) M18™ REDLITHIUM™ XC 4.0 Extended Capacity Battery Pack (48-11-1840)	(2) M18™ XC High Capacity RED LITHIUM™ Battery (48-11-1828)
Charger included with Kit	(1) M18™ & M12™ Multi-Voltage Charger (48-59-1812)	(1) M18™ & M12™ Multi-Voltage Charger (48-59-1812)	(1) M18™ & M12™ Multi-Voltage Charger (48-59-1812)	(1) M18™ & M12™ Multi-Voltage Charger (48-59-1812)	(1) M18™ & M12™ Multi-Voltage Charger (48-59-1812)	(1) M18™ & M12™ Multi-Voltage Charger (48-59-1812)	(1) M18™ & M12™ Multi-Voltage Charger (48-59-1812)
Torque	1,600 in.-lbs.	1,500 in lbs.	210 ft-lbs (2,520 in.-lbs)	167 ft.-lbs.	166 ft.-lbs.	2200 in.-lbs.	---
RPM	0-2,900 No Load RPM 0-3,600 No Load RPM	0-2,750 IPM 0-2,750 RPM	0-2,400 RPM	0-2450 RPM	0-2450 RPM	0-3,000 SPM	0-3200 SPM
Length	5-1/2"	5-1/2"	6"	6"	6"	18-1/2"	17 3/4"
Kit Tool Weight	3.6 lbs. (with Battery)	3.8 lbs.	6 lbs.	4.1 lbs. (Ship Wt: 11.68 lbs.)	4.1 lbs. (Ship Wt: 11.66 lbs.)	8.9 lbs.	7.9 lbs. (Ship Wt: 18.3 lbs.)
Additional Features	•	• Anvil Size: 1/4" • Anvil Type: Hex • On-Board Fuel Gauge on Battery	•	• Anvil Size: 1/2" • Anvil Type: Detent • On-Board Fuel Gauge • LED Light • Variable Speed Trigger • Belt Clip	• Anvil Size: 3/8" • Anvil Type: Ring • On-Board Fuel Gauge • LED Light • Variable Speed Trigger • Belt Clip	• Blade Clamp: QUIK-LOK® Universal • LED Light	• On-Board Fuel Gauge • LED Light • Patented Gear protecting clutch • Keyless Quik-Lok blade system • Counter balance for reduced vibration • 1" stroke



	FUEL™ (Brushless Motor) 4-1/2" / 5" Grinder	FUEL™ (Brushless Motor) 4-1/2" / 5" Grinder	Cut-Off / Grinder	7/8" SDS Plus Rotary Hammer	FUEL™ (Brushless Motor) 6-1/2" Circular Saw	5 3/8" Metal Saw
Kit	9704-76478 Paddle Switch Kit w/1 XC4.0 Battery Milwaukee 2780-21 9704-76479 Paddle Switch Kit w/2 XC4.0 Batteries Milwaukee 2780-22	9704-89784 Saddle Switch Kit w/1 XC4.0 Battery Milwaukee 2781-21 9704-89785 Saddle Switch Kit w/2 XC4.0 Batteries Milwaukee 2781-22	9701-98850 Milwaukee 2680-22	9703-51239 Milwaukee 2605-22	9704-76475 Kit w/1 XC4.0 Battery Milwaukee 2730-21 9704-76476 Kit w/2 XC4.0 Batteries Milwaukee 2730-22	9703-42450 Milwaukee 2682-22
Bare Tool Only	Paddle Switch 9704-76477 Milwaukee 2780-20	Slide Switch 9704-76480 Milwaukee 2781-20	9701-98849 Milwaukee 2680-20	9703-51826 Milwaukee 2605-20	9704-76474 Milwaukee 2730-20	9703-61502 Milwaukee 2682-20
Batteries included with Kit	(2) M18™ REDLITHIUM™ XC 4.0 Extended Capacity Battery Pack (48-11-1840)	(2) M18™ REDLITHIUM™ XC 4.0 Extended Capacity Battery Pack (48-11-1840)	(2) M18™ XC High Capacity RED LITHIUM™ Batteries (48-11-1828)	(2) M18™ XC High Capacity RED LITHIUM™ Batteries (48-11-1828)	(2) M18™ REDLITHIUM™ XC 4.0 Extended Capacity Battery Pack (48-11-1840)	(2) M18™ XC High Capacity RED LITHIUM™ Batteries (48-11-1828)
Charger included with Kit	(1) M18™ & M12™ Multi-Voltage Charger (48-59-1812)	(1) M18™ & M12™ Multi-Voltage Charger (48-59-1812)	(1) M18™ & M12™ Multi-Voltage Charger (48-59-1812)	(1) M18™ & M12™ Multi-Voltage Charger (48-59-1812)	(1) M18™ & M12™ Multi-Voltage Charger (48-59-1812)	(1) M18™ & M12™ Multi-Voltage Charger (48-59-1812)
Torque	---	---	---	---	---	---
RPM	8,500 RPM	8,500 RPM	9,000 RPM	0-1,400 RPM	5,000 RPM	3600 RPM
Length	15"	15"		11.75"	16"	14"
Kit Tool Weight	5.8 lbs.	5.8 lbs.	5.9 lbs. (Ship Wt: 13.25 lbs.)	7.2 lbs. (Ship Wt: 16.9 lbs.)	8 lbs.	Tool weight 4.3 lbs.
Additional Features	• Vibration Reduction • Tool Free Guard • 5/8" - 11 Arbor Size	• Vibration Reduction • Tool Free Guard • 5/8" - 11 Arbor Size	• On-Board Fuel Gauge • LED Light • Paddle Switch • Tool Free Guard • Large Button Spindle Lock • Type 1 Guard • Type 27 Guard • 3-Position Side Handle	• On-Board Fuel Gauge • LED Light • Impact Energy 1.8 ft.-lbs. • Max Capacity: 7/8" • Thin Wall Core Bit Capacity: 2-1/8" • Chipping • Clutch • Anti-Vibration - AVS™	• 5/8" Arbor Size • Magnesium Blade Guard and Shoe	• Superior cut quality: cool cut and burr free • LED light • On board fuel gauge • Cutting depth 1/8-2"



POWER TOOLS
BATTERY POWERED TOOLS

USA: 1-877-GO ALTEC
(1-877-462-5832)

www.alteccconnect.com

	FUEL™ Deep Cut Band Saw	18V Band Saw	1/2" Drive Impact Wrench	7/16" Impact Wrench	1/2" Hammer Drill	28V Sawzall
Kit	9706-37329 Kit w/1 XC4.0 Battery Milwaukee 2729-21 9706-37330 Kit w/2 XC4.0 Batteries Milwaukee 2729-22	9702-91835 Milwaukee 2629-22	9701-83730 Milwaukee 0779-22	9701-87404 Milwaukee 0799-20 KIT	9701-82160 Milwaukee 0726-22	9701-82179 Milwaukee 0719-22
Bare Tool Only	9705-87760 Milwaukee 2729-20	9703-51823 Milwaukee 2629-20	9701-99380 Milwaukee 0779-20	9701-82883 Milwaukee 0799-20	9702-79136 Milwaukee 0726-20	9702-67016 Milwaukee 0719-20
Batteries included with Kit	(2) M18™ REDLITHIUM™ XC 4.0 Extended Capacity Battery Pack (48-11-1840)	(2) M18™ XC High Capacity RED LITHIUM™ Batteries (48-11-1828)	(2) P/N 9701-82989 28V LITHIUM-ION Batteries (48-11-2830)	(2) P/N 9701-82989 28V LITHIUM-ION Batteries (48-11-2830)	(2) P/N 9701-82989 28V LITHIUM-ION Batteries (48-11-2830)	(2) P/N 9701-82989 28V LITHIUM-ION Batteries (48-11-2830)
Charger included with Kit	(1) M18™ & M12™ Multi-Voltage Charger (48-59-1812)	(1) M18™ & M12™ Multi-Voltage Charger (48-59-1812)	1 Hour Charger 48-59-2819	1 Hour Charger 48-59-2819	1 Hour Charger 48-59-2819	1 Hour Charger 48-59-2819
Voltage	18V	18V	28V	28V	28V	28V
Torque	-	-	3,900 in.-lbs./325 ft.-lbs.	3,900 in.-lbs./325 ft.-lbs.	750 in.-lbs.	--
RPM	0-380 SFPM	480 SFPM	0-1,450 (No Load) RPM	0-1,450 (No Load) RPM	0-450 / 0-1,800 RPM	0-3000 SPM
Length	21"	-	12-1/8"	11-3/4"	9-1/4"	15-7/8"
Kit Tool Weight	15 lbs.	10.25 lbs.	8.9 lbs. (Ship Wt: 19.1 lbs.)	Bare Tool Only - 7.6 lbs. (Ship Wt: 8.0 lbs.)	Bare Tool Only - 6.7 lbs. (Kit Ship Wt: 15 lbs.)	9.4 lbs. (Ship Wt: 19.2 lbs.)
Additional Features	<ul style="list-style-type: none"> Capacity: 5" x 5" Hang Hook Jobsite Armor Technology 	<ul style="list-style-type: none"> On-Board Fuel Gauge LED Light No Load Speed: 480 Loaded Speed: 390 Rectangular Capacity: 3-1/4" x 3-1/4" Round Capacity: 3-1/4" On/Off Trigger Switch Blade Length: 35-3/8" Great for cutting cable, guide wire, ground rod 	<ul style="list-style-type: none"> On-Board Fuel Gauge LED Light 1/2" Square Drive Reversible Battery 3.0 Amp Hours Trigger Lock Off 	<ul style="list-style-type: none"> On-Board Fuel Gauge LED Light 	<ul style="list-style-type: none"> On-Board Fuel Gauge LED Light 	<ul style="list-style-type: none"> On-Board Fuel Gauge LED Light Variable Speed Stroke Length: 1-1/8"



SELECTION GUIDE BATTERY-POWERED TOOLS

Selecting the Milwaukee tool with the right capacities is easy. After reviewing the guides on these pages to ensure that the tool you select has all the features you need, if you have any additional questions, please call 1-877-GO ALTEC (1-877-462-5832) or contact your Altec Supply Account Manager.

Nothing But HEAVY DUTY®



	28V Grinder / Cut-Off Tool	28V SDS Rotary Hammer	28V Band Saw
Kit	9701-82908 Milwaukee 0725-21	9701-82889 Milwaukee 0756-22	9701-82887 Milwaukee 0729-21
Bare Tool Only	9701-82908 Milwaukee 0725-20	9703-51844 Milwaukee 0756-20	9703-52163 Milwaukee 0729-20
Batteries included with Kit	(1) P/N 9701-82989 28V LITHIUM-ION Batteries (48-11-2830)	(2) P/N 9701-82989 28V LITHIUM-ION Batteries (48-11-2830)	(1) P/N 9701-82989 28V LITHIUM-ION Battery (48-11-2830)
Charger included with Kit	1 Hour Charger 48-59-2819	1 Hour Charger 48-59-2819	1 Hour Charger 48-59-2819
Torque	-	-	-
RPM/SPM	8000 (No load) RPM	0-1,400 RPM	0-350 SFPM
Length	14"	13"	22 in.
Kit Tool Weight	6.8 lbs. (Ship Wt: 14 lbs.)	Bare Tool Only - 9.6 lbs. (Kit Ship Wt: 17.4 lbs.)	19.6 lbs. (Ship Wt: 33.5 lbs.)
Additional Features	<ul style="list-style-type: none"> On-Board Fuel Gauge LED Light Variable Speed Spindle: 5/8"-11 Slide-on Switch Spindle lock 	<ul style="list-style-type: none"> On-Board Fuel Gauge LED Light Thin Wall Core Bit Capacity: 2-1/2" *1" Solid Bit Capacity 	<ul style="list-style-type: none"> On-Board Fuel Gauge LED Light No Load Speed: 0-225/0-350 FPM Rectangular Capacity: 4-3/4" x. 4-3/4"

Milwaukee TOOLS & ACCESSORIES

FOR BATTERY-POWERED TOOLS

Nothing But HEAVY DUTY®

POWER TOOLS
BATTERY POWERED TOOLS

USA: 1-877-GO ALTEC
(1-877-462-5832)

www.alteconnect.com

Milwaukee Battery Packs & Chargers



P/N 9701-82989



P/N 9701-82992



P/N 9701-82987



P/N 9703-28616



P/N 9706-37331



P/N 9702-32043



P/N 9703-55488



P/N 9702-41780



P/N 48-11-1820



P/N 9701-82987



P/N 48-11-1850



P/N 9705-32400

- P/N 9701-82989 features a battery fuel gauge, a performance optimizing circuit, and is eco-friendly
- P/N 9701-82992 features a 2.4 amp hour capacity for longer run time and easy-to-operate release latches
- P/N 9701-82987 features increased run-time with 40% less weight than an 18V NiCd battery, overload protection, a temperature management system, individual cell voltage monitoring, discharge protection, and a battery gauge
- P/N 9703-55488 accepts all M18™ and M12™ Battery Packs; Combo Charger charges batteries sequentially, utilizing a first in, first charged sequence. Charges Compact Batteries in 30 minutes or less, and charges XC Batteries in 60 minutes or less
- P/N 9701-83107 charges "V series" Li-Ion Batteries in 1 hour or less, NiCd Batteries in 40 minutes or less, and a pass-through plug conserves valuable outlet space
- P/N 9706-37331 is a 6 Bay Charger
- P/N 9702-41780 is designed for use with both M12™ RED LITHIUM™ and M12™ LITHIUM-ION batteries, and is a dually functional unit that has the capability to charge M12™ batteries in a traditional wall outlet or vehicle DC outlet
- P/N 48-59-1840 includes (1) M18™ REDLITHIUM™ XC 4.0 Extended Capacity Battery Pack (48-11-1840) (1) M18™ & M12™ Multi-Voltage Charger (48-59-1812)

P/N 9701-82989	48-11-2830	V28 LITHIUM-ION Battery Pack	P/N 9703-55488	48-59-1812	M18™ & M12™ Combo Charger
P/N 9701-82992	48-11-2230	18 Volt Battery	P/N 9703-28616	48-59-2819	18V-28V Universal Charger
P/N 9701-82987	48-11-1828	18V XC High Capacity LITHIUM-ION Battery	P/N 9706-37331	48-59-1806	6 Bay Charger
			P/N 9702-32043	2710-20	ACDC 18V Charger
			P/N 9702-41780	2510-20	ACDC 12V Charger

BATTERY PACKS:

P/N 9706-40861	48-11-1820	M18™ REDLITHIUM™ 2.0 Compact Battery Pack
P/N 9701-82987	48-11-1828	M18™ REDLITHIUM™ XC Extended Capacity Battery
P/N 9704-50021	48-11-1840	M18™ REDLITHIUM™ XC4.0 Extended Capacity Battery Pack
P/N 9706-40863	48-59-1840	M18™ REDLITHIUM™ XC4.0 System Starter Kit
P/N 9706-40866	48-11-1841	M18™ REDLITHIUM™ XC4.0 Battery Pack - 10 Pack
P/N 9706-40862	48-11-1850	M18™ REDLITHIUM™ XC5.0 Extended Capacity Battery Pack
P/N 9706-40864	48-59-1850	M18™ REDLITHIUM™ XC5.0 Extended Capacity Starter Kit
P/N 9706-40865	48-11-1852	M18™ REDLITHIUM™ XC5.0 Battery Pack
P/N 9705-32400	48-11-1822	M18™ REDLITHIUM™ High Capacity Battery Two Pack



P/N 48-59-1840

Ground Rod Driver Attachment



- SDS-Max Shank
- 5/8" hole and 10 1/2" overall length
- P/N 9701-83741 is for 5/8" and 3/4" Ground Rod
- Made from forged high grade steel
- All parts also available in spline drive

P/N 9701-83111	48-62-4091	SDS-Max Shank
P/N 9701-83145	48-62-4077	SDS Max 18" Bull Point
P/N 9701-83146	48-62-4085	SDS Max 2x12 Chisel
P/N 9701-83144	48-62-4081	SDS Max 1x12 Chisel
P/N 9701-83741	48-62-2046	For Spline Drive Hammer
P/N 9702-09163	48-62-2010	Spline Drive 18" Bull Point
P/N 9702-09164	48-62-2030	1X18 Chisel For Spline Driver
P/N 9702-09165	48-62-2050	2X12 Chisel For Spline Driver

7/16" Ship Auger Bits



- Nail-cutting tip for added durability
- Non-stick coated flutes for faster chip ejection
- Impact rated shank

P/N 9701-98852	48-13-5810	13/16" x 18"
P/N 9701-98853	48-13-5930	15/16" x 18"
P/N 9701-98854	48-13-5560	9/16" x 18"
P/N 9701-98901	48-13-5680	11/16" x 18"

5 3/8" Blade, 30 Teeth Per Inch

- Burr free cut and cool to touch cuts
- Last 25X longer than an abrasive blade
- Dry cut without messy lubricants
- Max RPM 4,500
- Great for clean cuts on cable
- For use with Model 2682-22

P/N 9703-43942 48-40-4070



TOOLS & ACCESSORIES

FOR BATTERY-POWERED TOOLS

General Purpose Ice Hardened™ Hole Saw Kit

- Ice Hardened™ for up to 50% longer life than the competition
- Optimized tooth form for up to 2X faster cutting
- Functional slots for faster plug removal
- Matrix II bi-metal teeth for greater durability
- P/N 9701-83152 15 Piece Hole Saw Kit Includes: (11) hole saws: 3/4", 7/8", 1", 1 1/8", 1 3/8", 1 1/2", 1 3/4", 2", 2 1/8", 2 1/4", 2 1/2", (2) arbors: 49-56-7010, 49-56-9100, (2) drill bits: 49-56-8010, (1) adapter: 49-56-6560, (1) spacer: 49-67-0120, and Space for additional hole saws
- P/N 9701-83153 28 Piece Hole Saw Kit Includes: Storage space for one (1) 12" extension or (2) 6" extensions
- Includes (22) hole saws: 3/4", 7/8", 1", 1 1/8", 1 1/4", 1 3/8", 1 1/2", 1 3/4", 2", 2 1/8", 2 1/4", 2 1/2", 2 5/8", 3", 3 1/4", 3 3/8", 3 5/8", 3 3/4", 4 1/8", 4 1/4", 4 1/2", 4 3/4", (3) Arbors: 49-56-7000, 49-56-7010, 49-56-9100 (3) Drill bits: 49-56-8010, and Space for additional hole saws

P/N 9701-83152 49-22-4175 15 Piece Shown Top Right
 P/N 9701-83153 49-22-4185 28 Piece Shown Lower Right



Ice Hardened™ The Torch® Sawzall® Blade



- Up to 50% longer life than the competition
- Matrix II bi-metal teeth for greater durability
- Positive rake angle for fast cutting
- Radiused tooth back reduces stress on teeth
- Deeper gullets for fast chip removal
- Utilize a proprietary cryogenic hardening process that improves upon traditional heat treat processes

P/N 9701-82172 48-00-4782 14T 6LG
 P/N 9701-82174 48-00-4784 18T 6LG
 P/N 9701-82175 48-00-4788 18T 9LG
 P/N 9701-82177 48-00-4787 14T 9LG

Super Sawzall Blade - 6 Teeth/Inch



- Bi-Metal Construction
 - 1/2" Universal Tang fits all Sawzalls
 - 5 blades per pouch
 - Fleam filed teeth for extremely sharp, fast cutting with a smooth edge in nail free wood and plastics
- P/N 9701-83131 48-00-1301 5 TPI, 9" Long
 P/N 9701-83121 48-00-5015 6 TPI, 6" Long
 P/N 9701-83124 48-00-5016 6 TPI, 9" Long
 P/N 9701-83126 48-00-5017 6 TPI, 12" Long

Keyless 3-Jaw Chuck, 7/16" Shank



- Allows you to adapt a three jaw chuck to a 7/16" hex chuck

P/N 9701-83149 48-66-0061

29 Piece Shockwave™ Driver Bit Set



- Engineered for extreme durability - up to 10x life
 - Made from proprietary steel and heat treated to control hardness
 - Innovatively designed geometric shock absorption zone to extend life
 - Forged tip allows for a secure grip and maximum contact - eliminating stripping or slipping
- Ideal for heavy duty impact applications,; delivers a full system solution for all the user's drilling and fastening needs
- Includes: Phillips Bits: 1" - (1) P1, (7) P2, (2) P3; 2" Power - (2) P2, (1) P3; Square Bits: 1" - (1) SQ1, (4) SQ2, (1) SQ3; 2" Power - (2) SQ2; Torx® Bits: 1" - (1) T15, (1) T20, (1) T25; 2" Power - (1) T25 Magnetic Nut Drivers: (1) 1/4" Red, (1) 5/16" Amber, (1) 3/8" Blue (1) Magnetic Bit Holder (1) Case with Bulk Storage Container

P/N 9702-50141 48-32-4401

21 Piece Thunderbolt® Black Oxide Drill Bit Set



- Black Oxide Jobber length drill bits are designed for extreme durability and long life
 - Thunderbolt® web features a thicker core than a standard drill bit, which provides ultimate strength and protects against side-load breakage
 - Specially designed parabolic flute form clears chips and debris fast to keep the bit cool
 - A precision start, 135 Split Point tip starts on contact to keep the bit from walking for fast, accurate holes
 - Excellent for drilling on curved surfaces, requires less effort to drill and is highly recommended for use with portable drills
 - The 3-Flat Secure-Grip shank won't slip in the drill chuck
 - Reduced shank diameter for use in 3/8" chucks
- Includes: (2) 1/16", (2) 5/64", (1) 3/32", (1) 7/64", (2) 1/8", (1) 9/64", (1) 5/32", (1) 11/64", (2) 3/16", (1) 13/64", (1) 7/32", (1) 15/64", (2) 1/4", (1) 5/16", (1) 3/8", (1) 1/2"

P/N 9703-59438 48-89-2801

POWER TOOLS
 BATTERY POWERED TOOLS

USA: 1-877-GO ALTEC
 (1-877-462-5832)

www.alteconnect.com

18V LXT® Lithium-Ion Cordless 7/16" Hex High Torque Impact Wrench

- Engineered for drilling and fastening into treated wood utility poles without rotational torque to help maintain balance
- Delivers 325 ft.lbs. of Max Torque, with 1,900 RPM and 2,200 IPM for powerful drilling and fastening
- Rocker switch for forward/reverse operation
- Compact design of 10 3/4" long; weighs 7.8 lbs.
- Built-in L.E.D. light illuminates the work area
- LXT® Lithium-Ion battery and Rapid Optimum Charger produces 430% total lifetime work with 3x more cycles

P/N 9703-98242 XWT01 7/16" Impact Wrench Kit (2 LXT® Batteries and 1 Rapid Charger)
P/N 9703-98243 XWT01Z Impact Wrench, Bare Tool Only



18V LXT® Lithium-Ion Cordless 3/8" Impact Wrench Kit

- Makita-built 4-pole motor delivers 155 ft.lbs. of Max Torque
- Variable speed (0-2,100 RPM & 0-3,200 IPM) for a wide range of fastening applications
- Compact design at only 6-1/8" long and weighs only 3.4 lbs. for reduced operator fatigue
- Soft grip handle provides increased comfort on the job
- Built-in L.E.D. light with afterglow illuminates the work area
- Ergonomic shape fits like a glove with even pressure and easy control
- 3-year warranty on tool and 1-year warranty on battery and charger
- LXT® Lithium-Ion battery and Rapid Optimum Charger produces 430% total lifetime work with 3x more cycles

P/N 9705-88761 BTW253 Impact Wrench Kit (2 LXT® Batteries and 1 Rapid Charger)
P/N 9705-88762 BTW253Z Impact Wrench, Bare Tool Only

18V LXT® Lithium-Ion Cordless 1/2" Impact Wrench Kit

- Makita-built 4-pole motor delivers 170 ft.lbs. of Max Torque
- 0-2,100 RPM & 0-3,200 IPM for a wide range of fastening applications
- Compact design at only 6-1/2" long
- Weighs only 3.8 lbs. with battery for reduced operator fatigue
- Built-in L.E.D. light with afterglow illuminates the work area
- Ergonomic shape fits like a glove with even pressure and easy control
- Soft grip handle provides increased comfort on the job
- Equipped with Star Protection Computer Controls™ to protect against overloading, over-discharging and over-heating Rapid Optimum Charger has a built-in fan to cool the battery to produce more lifetime work
- LXT® Lithium-Ion battery and Rapid Optimum Charger produces 430% total lifetime work with 3x more cycles
- 3-year warranty on tool and 1-year warranty on battery

P/N 9705-88763 XWT05 Impact Wrench Kit (2 LXT® Batteries and 1 Rapid Charger)
P/N 9705-88764 XWT05Z Impact Wrench, Bare Tool Only



18V LXT® Lithium-Ion Cordless 1/2" Impact Wrench Kit 325 ft.lbs. of Max Torque

- Makita-built motor delivers 325 ft.lbs. of Max Torque, with 1,600 RPM and 2,200 IPM for superior fastening power
- Shock absorbent handle protects battery housing for extra durability
- Rocker switch for forward/reverse operation
- Soft grip handle provides increased comfort on the job
- Compact design at only 10-1/2" long and weighs only 7.5 lbs. for reduced operator fatigue
- Built-in L.E.D. light illuminates the work area
- LXT® Lithium-Ion battery and Rapid Optimum Charger produces 430% total lifetime work with 3x more cycles
- 3-year warranty on tool
- Battery and charger sold separately

P/N 9705-88765 XWT04 Impact Wrench Kit (2 LXT® Batteries and 1 Rapid Charger)
P/N 9705-88766 XWT04Z Impact Wrench, Bare Tool Only

LXT[®]

LITHIUM-ION

70+ TOOLS



30 MINUTE CHARGE TIME

ONE BATTERY

18V LXT[®] Lithium-Ion Cordless 3/8" Angle Impact Wrench Kit 3/8" Angle Wrench for Work in Tight Spaces



- Makita-built motor delivers 44 ft.lbs. of Max Torque
- Variable speed (0-2,000 RPM & 0-3,000 IPM) for a wide range of fastening applications
- Compact 2-1/4" angle head height for use in close quarters
- Long, ergonomic body design provides maximum reach and weighs only 3.3 lbs. for reduced operator fatigue
- Large conveniently located paddle switch for comfortable operation
- Built-in L.E.D. light with afterglow illuminates the work area
- Soft grip handle provides increased comfort on the job

- LXT[®] Lithium-Ion battery and Rapid Optimum Charger produces 430% total lifetime work with 3x more cycles
- 3-year warranty on tool and 1-year warranty on battery and charger

P/N 9705-88767 BTL063 Impact Wrench Kit (2 LXT[®] Batteries and 1 Rapid Charger)
P/N 9705-88768 BTL063Z Impact Wrench, Bare Tool Only

18V LXT[®] Lithium-Ion Cordless Angle Impact Driver Kit Ideal for Fastening in Close Quarters

- Makita-built motor delivers 530 in.lbs. of Max Torque
- Variable speed (0-2,000 RPM & 0-3,000 IPM) for a wide range of fastening applications
- Compact 2-1/8" angle head height for use in close quarters
- Large paddle switch with soft grip provides increased comfort
- Convenient 1/4" hex chuck for quick bit changes
- Built-in L.E.D. light with afterglow illuminates the work area
- Soft grip handle provides increased comfort on the job
- Long, ergonomic body design provides maximum reach and weighs only 3.9 lbs. for reduced operator fatigue
- LXT[®] Lithium-Ion battery and Rapid Optimum Charger produces 430% total lifetime work with 3x more cycles
- 3-year warranty on tool and 1-year warranty on battery and charger



P/N 9705-88769 BTL061 Impact Driver Kit (2 LXT[®] Batteries and 1 Rapid Charger)
P/N 9705-88770 BTL061Z Impact Driver, Bare Tool Only

18V LXT[®] Lithium-Ion Cordless Impact Driver Kit



- Makita-built 4-pole motor delivers 1,420 in.lbs. of Max Torque
- Variable speed (0-2,300 RPM & 0-3,200 IPM) for a wide range of fastening applications
- Compact design at only 5-7/16" long and weighs only 3.3 lbs. for reduced operator fatigue
- Convenient one-touch 1/4" hex chuck for quick bit changes
- New redesigned rubberized soft grip provides increased comfort on the job
- Extreme Protection Technology (XPT) is engineered to provide improved dust and water resistance for operation in harsh conditions
- Built-in L.E.D. light with afterglow illuminates the work area
- Ergonomic shape fits like a glove with even pressure and easy control
- LXT[®] Lithium-Ion battery and Rapid Optimum Charger produces 430% total lifetime work with 3x more cycles
- 3-year warranty on tool and 1-year warranty on battery and charger

P/N 9704-54601 LXDT04 Impact Driver Kit (2 LXT[®] Batteries, 1 Rapid Charger)
P/N 9704-54604 LXDT04Z Impact Driver, Bare Tool Only

18V LXT[®] Lithium-Ion Cordless Brushless Quick-Shift Mode™ 3-Speed Impact Driver Kit

- Quick-Shift Mode™ selector has an automatic electronic controller that downshifts, reducing rotation/impact speed prior to driving screw into place; engineered to minimize screw thread stripping, screw breakage and damage to work
- 3-speed power selection switch (0-1,400 / 0-2,300 / 0-2,800 RPM & 0-1,300 / 0-2,800 / 0-3,400 IPM) provides the user with precise fastening control for a wide range of applications
- BL™ Brushless Motor delivers 1,500 in.lbs. of Max Torque
- Convenient one-touch 1/4" hex chuck for quick bit changes
- Built-in L.E.D. light with an independent on/off switch illuminates the work area
- New redesigned rubberized soft grip provides increased comfort on the job
- 3 stage battery warning light indicates with its time to recharge the battery
- Compact design at only 5-1/8" long and weighs just 3.3 lbs. for reduced operator fatigue
- The electronically-controlled BL™ Brushless Motor efficiently uses energy to match torque and RPM to the changing demands of the application
- Extreme Protection Technology (XPT) is engineered to provide improved dust and water resistance for operation in harsh conditions
- Efficient BL™ Brushless motor is electronically controlled to optimize battery energy use for up to 50% longer run time per charge
- The BL™ Brushless Motor eliminates carbon brushes, enabling the BL™ Motor to run cooler and more efficiently for longer life
- LXT[®] Lithium-Ion battery and Rapid Optimum Charger produces 430% total lifetime work with 3x more cycles

P/N 9705-88773 LXDT06 Impact Driver Kit (2 LXT[®] Batteries and 1 Rapid Charger)
P/N 9705-88774 LXDT06Z Impact Driver, Bare Tool Only



POWER TOOLS
BATTERY POWERED TOOLS

USA: 1-877-GO ALTEC
(1-877-462-5832)

www.alteconnect.com

Altec
Supply



INDUSTRIAL POWER TOOLS

**POWER TOOLS
BATTERY POWERED TOOLS**

**USA: 1-877-GO ALTEC
(1-877-462-5832)**

www.alteconnect.com

18V LXT® Lithium-Ion Hammer Driver-Drill **33% More Torque Than The Previous Model!**

- Makita-built 4-pole motor delivers 750 in. lbs. of Max Torque
- Mechanical 2-speed transmission (0-400 & 0-2,000 RPM)
- Compact design at only 8 7/8" long and weighs only 5.1 lbs.
- Extreme Protection Technology (XPT) engineered for increased dust and water resistance for operations in harsh jobsite conditions
- All metal gears and aluminum gear housing for maximum jobsite durability
- Shift-Lock™ Drive System quickly shifts between modes
- Dual L.E.D. lights with afterglow enhanced illumination of work area
- Ergonomic shape fits like a glove with even pressure and easy control
- Soft grip handle provides increased comfort on the job
- LXT® Lithium-Ion battery and Rapid Optimum Charger produces 430% total lifetime work with 3x more cycles

P/N 9703-98249 LXP03 Hammer Drill Kit (2 LXT® Batteries and 1 Rapid Charger)
P/N 9703-98250 LXP03Z Hammer Drill, Bare Tool Only



18V LXT® Lithium-Ion Brushless Cordless **1/2" Hammer Driver-Drill Kit**

- BL™ Brushless Motor delivers 530 in.lbs. of Max Torque
- Variable 2-speed (0-400 & 0-1,550 RPM) for a wide range of drilling, fastening, hammer drilling applications
- Efficient BL™ Brushless motor is electronically controlled to optimize battery energy use for up to 50% longer run time per charge
- The BL™ Brushless Motor eliminates carbon brushes, enabling the BL™ Motor to run cooler and more efficiently for longer life
- The electronically controlled BL™ Brushless Motor efficiently uses energy to match torque and RPM to the changing demands of the application
- Compact and ergonomic design at only 7-7/8" long; weighs only 3.9 lbs. for reduced operator fatigue
- Extreme Protection Technology (XPT) for improved dust and water resistance in harsh job site conditions
- 3-stage L.E.D. gauge indicates battery charge level
- Equipped with Star Protection Computer Controls™ to protect against overloading, over-discharging and over-heating
- All metal gears for increased durability
- Built-in L.E.D. light illuminates the work area
- Redesigned rubberized soft grip provides increased comfort on the job
- LXT® Lithium-Ion battery and Rapid Optimum Charger produces 430% total lifetime work with 3x more cycles

P/N 9705-88775 XPH06 Hammer Drill Kit (2 LXT® Batteries and 1 Rapid Charger)
P/N 9705-88776 XPH06Z Hammer Drill, Bare Tool Only



18V X2 LXT®

Lithium-Ion Cordless Chainsaw (Bare Tool) **POWERED BY TWO 18V LXT® LITHIUM-ION BATTERIES**

- Makita-Built Motor Delivers 1,650 FPM for Increased Cutting Speed
- 12" Guide Bar for Increased Capacity
- Requires (2) 18V LXT® Lithium-Ion Batteries
- Lower Noise Level at Only 89 dB(A) for Improved User Comfort
- Front Hand Guard Engineered to Actuate Electric Brake When Engaged
- "Tool-Less" Chain Adjustments for Convenient Operation and Maintenance
- Deliver the Power and Run Time for Corded Demands Without Leaving the 18V LXT® Platform
- Zero Emissions and Reduced Maintenance, With No Need to Change Spark Plug, Clean Air Filter or Drain Fuel for Storage

P/N 9704-90660 HCU02ZX2 18V X2 LXT® Lithium-Ion Cordless Chainsaw, Bare Tool Only
P/N 9704-90661 BCV02 LXT® Battery Adapter
P/N 9704-90662 531-290-046 Chain
P/N 9704-90663 165245-8 Guide Bar
P/N 9704-90664 952-010-640 Blade Cover



18V LXT® Lithium-Ion Cordless Reciprocating Saw

- Makita-built variable speed motor delivers 0-2,900 strokes per minute combined with a 1 1/8" length stroke to provide faster cutting
- "Tool-less" blade change system
- Two built-in L.E.D. lights illuminate the work area
- Large 2-finger variable speed trigger for added convenience
- Retractable tool hook secures the tool when not in use
- Compact, ergonomic design at 19 5/8" long and only 8.2 lbs.
- LXT® Lithium-Ion battery and Rapid Optimum Charger produces 430% total lifetime work with 3x more cycles

P/N 9703-98244 XRJ02 1-1/8" Reciprocating Saw Kit, 2 LXT® Batteries, 1 Rapid Charger, 1 Blade
P/N 9703-98245 XRJ02Z 1-1/8" Reciprocating Saw, 1 Blade, Bare Tool Only



LXT[®]

LITHIUM-ION

70+ TOOLS



30 MINUTE CHARGE TIME

ONE BATTERY

18V LXT[®] Lithium-Ion Cordless Compact Band Saw Kit

Suitable for appropriate one-handed operation



- Makita-built motor delivers 630 ft./min. blade speed for fast cutting
- Accepts standard 32-7/8" x 1/2" blades
- Built-in L.E.D. light illuminates the work area
- Protective bumper design for added durability
- "Tool-less" blade change system for fast blade installation and removal
- Adjustable foot protects material and provides improved support for accurate cutting
- Soft grip handle provides increased operator comfort
- Tool hook secures the tool when not in use
- Includes a blade wheel cover that covers the blade outside the cutting area making the saw suitable for appropriate one-handed operation*
- 3-year warranty on tool 1-year warranty on battery
- Meets ANSI Standard 60745-2-20

- Compact design at 18-1/2 long; weighs only 7.5 lbs. (with battery) for convenient operation
- 2-1/2" cutting capacity is ideal for cutting conduit, Unistrut[®], copper pipe, threaded rod, angle iron and channel

P/N 9705-88777 XBP01

Compact Band Saw Kit (2 LXT[®] Batteries and 1 Rapid Charger)

P/N 9705-88778 XBP01Z

Compact Band Saw, Bare Tool Only

18V LXT[®] Lithium-Ion Cordless Portable Band Saw Kit

Suitable for appropriate one-handed operation

- Makita-built motor delivers faster cutting with 275-530 ft./min.
- 6-setting variable speed control dial enables user to match the speed to the application
- Compact design at only 20-5/8" long and weighs only 14.3 lbs. for reduced operator fatigue
- Built-in L.E.D. protection circuit with over-torque control protects motor
- Tool hook secures the tool when not in use
- Adjustable foot protects material & provides positive support for accurate cuts
- Protective bumper design for added durability
- Built-in L.E.D. light illuminates the work area
- Soft grip handle provides increased comfort on the job
- LXT[®] Lithium-Ion battery and Rapid Optimum Charger produces 430% total lifetime work with 3x more cycles
- 3-year warranty on tool and 1-year warranty on battery and charger

P/N 9705-88779 XBP02

Compact Band Saw Kit (2 LXT[®] Batteries and 1 Rapid Charger)

P/N 9705-88780 XBP02Z

Compact Band Saw, Bare Tool Only



18V LXT[®] Lithium-Ion Cordless 4-1/2" Cut-Off/Angle Grinder

- Makita-built motor delivers 10,000 RPM for faster grinding
- Compact, ergonomic design at 12-1/2" long and only 5.0 lbs.
- Slide switch with lock-on for operator convenience
- Built-in L.E.D. protection circuit with over-torque control protects the motor
- LXT[®] Lithium-Ion battery and Rapid Optimum Charger produces 430% total lifetime work with 3x more cycles

P/N 9703-98246 XAG01 4 1/2" Grinder Kit (2 LXT[®] Batteries, 1 Rapid Charger)

P/N 9703-98247 XAG01Z 4 1/2" Grinder, Bare Tool Only

18V LXT[®] Lithium-Ion Cordless 5-3/8" Metal Cutting Saw

- Makita-built motor delivers 3,600 RPM for faster cutting in a wide range of metals including Unistrut[®] all thread, channel, conduit, pipe, sheet metal, square tubing, steel and more
- Compact, ergonomic design at 13-3/4" long and weighs only 5.7 lbs. for reduced operator fatigue
- Built-in L.E.D. light illuminates the work area
- Soft grip handle for increased comfort on the job

P/N 9705-88781 XSC01 Kit - Metal Cut Saw (2 LXT[®] Batteries and 1 Rapid Charger)

P/N 9705-88782 XSC01Z Bare Tool Metal Cut Saw



POWER TOOLS
BATTERY POWERED TOOLS

USA: 1-877-GO ALTEC
(1-877-462-5832)

www.alteconnect.com

18V LXT® Lithium-Ion Cordless 7/8" Rotary Hammer Kit; Accepts SDS-PLUS Bits Compact Pistol Grip Design

- Makita-built variable speed motor delivers 0-1,100 RPM and 0-4,000 BPM
- Faster drilling with synchronized RPM and BPM
- 3-mode operation for "Rotation Only", "Hammering with Rotation" or "Hammering Only" for multiple applications
- Jobsite tested shock absorbent handle protects the battery housing for extra durability
- Torque limiting clutch reduces gear damage by automatically disengaging gears if bit binds
- One-touch sliding chuck for quick bit changes
- Chisel rotates 360° with 40 different positions
- Compact pistol grip design at only 14-1/8" long and weighs only 7.7 lbs. for reduced operator fatigue
- Large 2-finger variable speed trigger for added convenience
- Built-in L.E.D. light with afterglow illuminates the work area
- Soft grip handle provides increased comfort on the job
- LXT® Lithium-Ion battery and Rapid Optimum Charger produces 430% total lifetime work with 3x more cycles
- 3-year warranty on tool and 1-year warranty on batteries and charger

P/N 9705-88783 BHR202 Rotary Hammer Kit (2 LXT® Batteries and 1 Rapid Charger)
P/N 9705-88784 BHR202Z Rotary Hammer, Bare Tool Only



36V LXT® Lithium-Ion (36V) Cordless 1" Rotary Hammer Accepts SDS-PLUS bits (Tool Only)

The 18 Volt Solution for Corded Power Demands

- Two 18V LXT® Lithium-Ion batteries deliver 36V power and run time for corded demands without leaving the 18V LXT® platform
- Makita-built motor delivers 0-1,200 RPM, 0-4,800 BPM and 3.0 Joules of impact energy for faster drilling
- Vibration-absorbing handle engineered for increased operator comfort
- Ergonomic soft-grip handle and large 2-finger trigger provides increased comfort on the job
- L.E.D. battery indicators show charge level for each battery
- 3-Mode operation for rotation only, hammering with rotation, or hammering only
- SDS-PLUS shank offers rotates 360° with 40 different positions One-touch sliding chuck for easy bit changes
- Torque Limiting Clutch engineered to prevent gear damage by automatically disengaging gears if the bit binds
- Compact design at only 14-1/4 long and weighs only 11.3 lbs. (with batteries)
- Built-in L.E.D. light illuminates the work area
- LXT® Lithium-Ion battery and Rapid Optimum Charger produces 430% total lifetime work with 3x more cycles
- 3-year warranty on tool and 1-year warranty on batteries and charger

P/N 9705-88785 HRH01ZX2 Rotary Hammer Tool Only (Kit Not Available)



18V LXT® Lithium-Ion Battery

- LXT® Lithium-Ion batteries and Rapid Optimum Chargers produce 430% total lifetime work with 2.5x more cycles than Ni-Cd batteries
- LXT® Lithium-Ion Batteries weigh 40% less than Ni-Cd

P/N 9702-16519 BL1830 Lithium Battery
(Charge Time: 15 Min. (Compact Battery) & 30 Min. (LXT® Battery))



P/N 9702-16519 BL1830

18V LXT® Lithium-Ion Chargers

- During the charging process, the Rapid Optimum Charger monitors each battery and actively controls the current, voltage and temperature for faster charging and longer battery life
- Rapid Optimum Charger has a built-in fan to cool the battery during the charging process, which is engineered to facilitate a faster charge time and helps product lifetime work
- Rapid Optimum Charger is ENERGY STAR® qualified
- Compact design (7-12" Long, only 1.6 lbs.) is ideal for jobsite portability and storage

P/N 9703-98248 DC18RC Standard Charger
(Charge Times: 15 Min. (Compact Battery) & 30 Min. (LXT® Battery))



P/N 9703-98248 DC18RC

P/N 9702-16796 DC18SE Automotive Charger
(Charge Times: 30 Min. (Compact Battery) & 60 Min. (LXT® Battery))



P/N 9702-16796 DC18SE

18V LXT® Lithium-Ion 4Bay Charger

- Charges 2 18V LXT® batteries in 60 minutes and 4 18V LXT® batteries in 120 minutes
- Charges 2 18V Compact batteries in 30 minutes and 4 18V Compact batteries in 60 minutes
- Compact design (17.3" long, only 4.5 lbs.) is ideal for a jobsite gang or tool boxes
- Charger indicators provide updates on charging progress or charging status
- Rapid optimum 4-part charger is Energy Star® qualified

P/N 9705-88786 DC18SF LXT 4 Bay Charger



P/N 9705-88786 DC18SF



	7/16" Hex Impact Wrench	3/8" Impact Wrench	1/2" Impact Wrench	1/2" Impact Wrench	3/8" Angle Impact Wrench	Angle Impact Driver	Impact Driver	3-Speed Impact Driver
Kit	9703-98242 Makita XWT01	9705-88761 Makita BTW253	9705-88763 Makita XWT05	9705-88765 Makita XWT04	9705-88767 Makita BTL063	9705-88769 Makita BTL061	9704-54601 Makita LXDT04	9705-88773 Makita LXDT06
Bare Tool Only	9703-98243 Makita XWT01Z	9705-88762 Makita BTW253Z	9705-88764 Makita XWT05Z	9705-88766 Makita XWT04Z	9705-88768 Makita BTL063Z	9705-88770 Makita BTL061Z	9704-54604 Makita LXDT04Z	9705-88774 Makita LXDT06Z
Batteries included with Kit	(2) 9702-16519 LXT® Lithium-Ion Batteries (Makita BL1830)	(2) 9702-16519 LXT® Lithium-Ion Batteries (Makita BL1830)	(2) 9702-16519 LXT® Lithium-Ion Batteries (Makita BL1830)	(2) 9702-16519 LXT® Lithium-Ion Batteries (Makita BL1830)	(2) 9702-16519 LXT® Lithium-Ion Batteries (Makita BL1830)	(2) 9702-16519 LXT® Lithium-Ion Batteries (Makita BL1830)	(2) 9702-16519 LXT® Lithium-Ion Batteries (Makita BL1830)	(2) 9702-16519 LXT® Lithium-Ion Batteries (Makita BL1830)
Charger included with Kit	(1) 9703-98248 (Makita DC18RC) 18V LXT® Charger	(1) 9703-98248 (Makita DC18RC) 18V LXT® Charger	(1) 9703-98248 (Makita DC18RC) 18V LXT® Charger	(1) 9703-98248 (Makita DC18RC) 18V LXT® Charger	(1) 9703-98248 (Makita DC18RC) 18V LXT® Charger	(1) 9703-98248 (Makita DC18RC) 18V LXT® Charger	(1) 9703-98248 (Makita DC18RC) 18V LXT® Charger	(1) 9703-98248 (Makita DC18RC) 18V LXT® Charger
Voltage	18V	18V	18V	18V	18V	18V	18V	18V
Torque	325 ft. lbs.	155 ft.-lbs.	170 ft.-lbs.	325 ft. lbs.	44 ft. lbs.	530 in. lbs.	1,420 in. lbs.	1,500 in. lbs.
RPM/SPM	1,900 RPM / 2,200 IPM	0-2, 100 RPM / 0-3, 200 IPM	0-2, 100 RPM / 0-3, 200 IPM	1,600 RPM / 2,200 IPM	0-2,000 RPM / 0-3,000 IPM	0-2,000 RPM / 0-3,000 IPM	0-2,300 RPM / 0-3,200 IPM	0-1,400 RPM / 0-2,300 RPM / 0-3,200 RPM & 0-1,300 IPM / 0-2,800 IPM / 0-3,400 IPM
Length	10-3/4"	6-1/8"	6-1/2"	10-1/2"			5-7/16"	5-1/8"
Kit Tool Weight	7.8 lbs.	3.4 lbs.	3.8 lbs.	7.5 lbs.	3.3 lbs.	3.9 lbs.	3.3 lbs.	3.3 lbs.
Additional Features	• High Torque				• 2-1/4" Angle Head height for use in Close Quarters	• 1/4" Hex Chuck for Quick Bit Changes • 2-1/4" Angle Head height for use in Close Quarters • Built-in LED light with afterglow		



	Hammer Driver-Drill	Brushless 1/2" Hammer Driver-Drill	1-1/8" Reciprocating Saw	Compact Band Saw Kit	Portable Band Saw Kit	4-1/2" Cut-Off Angle Grinder	5-3/8" Metal Cutting Saw	Hammer Drill / Driver
Kit	9703-98249 Makita LXPH03	9705-88775 Makita XPH06	9703-98244 Makita XRJ02	9705-88777 Makita XBP01	9705-88779 Makita XBP02	9703-98246 Makita XAG01	9705-88781 Makita XSC01	
Bare Tool Only	9701-98250 Makita LXPH03Z	9705-88776 Makita XPH06Z	9703-98245 Makita XRJ02Z	9705-88778 Makita XBP01Z	9705-88780 Makita XBP02Z	9703-98247 Makita XAG01Z	9705-88782 Makita XSC01Z	9705-88783 Makita BHR202 (KIT) 9705-88784 Makita BHR202Z (BARE TOOL)
Batteries included with Kit	(2) 9702-16519 LXT® Lithium-Ion Batteries (Makita BL1830)	(2) 9702-16519 LXT® Lithium-Ion Batteries (Makita BL1830)	(2) 9702-16519 LXT® Lithium-Ion Batteries (Makita BL1830)	(2) 9702-16519 LXT® Lithium-Ion Batteries (Makita BL1830)	(2) 9702-16519 LXT® Lithium-Ion Batteries (Makita BL1830)	(2) 9702-16519 LXT® Lithium-Ion Batteries (Makita BL1830)	(2) 9702-16519 LXT® Lithium-Ion Batteries (Makita BL1830)	(2) 9702-16519 LXT® Lithium-Ion Batteries (Makita BL1830)
Charger included with Kit	(1) 9703-98248 (Makita DC18RC) 18V LXT® Charger	(1) 9703-98248 (Makita DC18RC) 18V LXT® Charger	(1) 9703-98248 (Makita DC18RC) 18V LXT® Charger	(1) 9703-98248 (Makita DC18RC) 18V LXT® Charger	(1) 9703-98248 (Makita DC18RC) 18V LXT® Charger	(1) 9703-98248 (Makita DC18RC) 18V LXT® Charger	(1) 9703-98248 (Makita DC18RC) 18V LXT® Charger	(1) 9703-98248 (Makita DC18RC) 18V LXT® Charger
Voltage	18V	18V	18V	18V	18V	18V	18V	18V
Torque	750 in. lbs.	530 in. lbs.	-	630 ft./min.	275-530 ft./min.	-	-	525 in.-lbs.
RPM/SPM	0-400 & 0-2,000 RPM	0-400 & 0-1,550 RPM	0-2,900 SPM	-	-	10,000 RPM	3,600 RPM	0-1,100 RPM and 0-4,000 BPM
Length	8-7/8"	7-7/8"	19-5/8"	18-1/2"	20-5/8"	12-1/2"	13-3/4"	14-1/8"
Kit Tool Weight	5.1 lbs.	3.9 lbs.	8.2 lbs.	7.5 lbs.	14.3 lbs.	5.0 lbs.	5.7 lbs.	7.7 lbs.
Additional Features		• 3-Stage LED Gauge indicates Battery Charge Level	• 1-1/8" Length Stroke	• Accepts Standard 32-7/8" x 1/2" Blades • 2-1/2" Cutting Capacity				

POWER TOOLS
BATTERY POWERED TOOLS

USA: 1-877-GO ALTEC
(1-877-462-5832)

www.alteconnect.com

AIRCRAFT DYNAMICS™

POWER TOOLS
BATTERY POWERED TOOLS

USA: 1-877-GO ALTEC
(1-877-462-5832)

www.alteconnect.com

R
O
B
O

I
M
P
A
C
T
S

IMPACT WRENCH

P/N 9706-37362 5601 Tool, (1) Lithium-Ion Battery, AC Charger
 P/N 9704-97105 5600 Tool, (2) Lithium-Ion Batteries, AC Charger
 P/N 9706-37363 5602 Tool, (1) Lithium-Ion Battery, AC Charger, Inverter
 P/N 9704-97114 5603 Tool, (2) Lithium-Ion Batteries, AC Charger, Inverter
 P/N 9706-37364 3419 19.2 V Lithium-Ion Battery
 P/N 9706-37365 4419 Lithium-Ion AC Battery Charger
 P/N 9706-37366 4420 Inverter



The **lightest weight-to-power cordless impact** in the world! Extremely small, lightweight, powerful and durable. It will handle all your drilling and hardware needs. The cushioned handle and "gun like" feel will increase job efficiency, reduce operator fatigue, and allow use in environments where hoses and cords are unsafe or inconvenient.



- Voltage: 19.2v
- Ft./Lbs. of Torque: 350
- Impacts Per Minute: 0 - 2300
- Chuck: 7/16" Hex Quick-Change
- Cordless Battery: 19.2v Lithium - Ion
- Charging Options: AC
- Weight (Tool and Battery): 5.7 lbs.



BLUE BULLY
7/16" Hex to 1/2" Sq. Drive
P/N 9701-98707 2801



CORDLESS 36V DC IMPACT

P/N 9701-86297 5309 Tool, (1) Lithium-Ion Battery, AC Charger
 P/N 9703-57788 5310 Tool, (2) Lithium-Ion Batteries, AC Charger
 P/N 9703-00876 2756 36V Lithium-Ion Battery
 P/N 9703-57792 4376 Lithium-Ion AC Battery Charger

- Voltage: 36v
- Ft./Lbs. of Torque: 450
- Impacts Per Minute: 2500
- Chuck: 7/16" Hex Quick-Change
- Cordless Battery: Hilti 3.0 amp/hr. Li-ion
- Charging: AC Li-ion
- Weight (Tool and Li-ion Battery): 12.5 lbs.
- Average drill time in 10" diameter pole: 9 seconds
- Average number of holes per charge in 10" diameter pole: 20+

SMARTER

SAFER

STRONGER

AIRCRAFT ~~A~~ DYNAMICS™

ROBO
TOOLS

ROBOTool BLACK WIDOW BITS

Robotool Black Widow bits are rugged heat treated and with proprietary flute design, self-feeding screw and cutting spur, will cut through the hardest poles with ease and will decrease average drilling times by 50%. Available for Hollow Core, Solid Foam Core or Wood Poles.

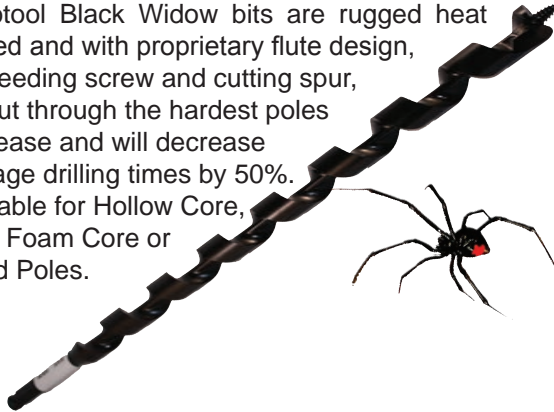

DRILL BIT HOLDER

P/N 9701-98792 9296

- Holds four pole bits up to 1" diameters and any length
- Will mount in vehicles or on any vertical surface
- Weather proof — will not rust



1/2" KEYED CHUCK KIT

P/N 9701-86306 2590



- Kit includes: Chuck and attached 7/16" Blue Bully Hex Drive Adapter
- Keyed 3 jaw chuck adapter for wood or fiberglass use with impacts to drill holes in steel, wood, or fiberglass

1/2" KEYLESS CHUCK

P/N 9703-28388 2530



- Keyless 3 jaw chuck adapter for use with impacts to drill holes in steel, wood, or fiberglass
- Not for use with use with bits that cause continuous impacting

WOOD BITS 7/16" SHANK

ALTEC PART NO.	CATALOG NUMBER	BIT DIAMETER	LENGTH
9701-86730	2525	9/16"	18"
9701-88912	2523	11/16"	18"
9701-86731	2524	13/16"	18"
9701-96931	2526	15/16"	18"
9706-37367	2516	1"	18"
9706-37368	2542	1-1/16"	18"
9706-37369	2533	1-1/8"	18"
9701-98710	2527	11/16"	24"
9701-98711	2528	13/16"	24"
9706-37370	2543	7/8"	24"
9701-98790	2529	15/16"	24"
9706-37371	2532	1"	24"
9701-98791	2531	1-1/16"	24"
9706-37372	2534	1-1/8"	24"
9706-37373	2536	1-1/4"	24"
9706-37374	2537	1-3/8"	24"

POWER TOOLS
BATTERY POWERED TOOLS

USA: 1-877-GO ALTEC
(1-877-462-5832)

www.alteconnect.com

SMARTER

- SAFER

- STRONGER

COMPRESSION DIES

**POWER TOOLS
COMPRESSION DIES**

**USA: 1-877-GO ALTEC
(1-877-462-5832)**

www.alteconnect.com

DIE SELECTION CHART

APPROXIMATE CONDUCTOR RANGE		DIE COLOR CODE	HUSKIE		BURNDY		GREENLEE	
CU	AL		ALTEC	HUSKIE	ALTEC	BURNDY	ALTEC	GREENLEE
6 AWG	8 AWG	BLUE	970366434 / 970366435	HT41AT / HT41GL	970189363 / 970366454	U5CRT / U8CABT	970103585 / 970103570	KC12-6 / KA12-8
4 AWG	6 AWG	GREY	970366436 / 970366437	HT41AU / HT41GE	970189364 / 970366455	U4CRT / U6CABT	970103588 / 970103574	KC12-4 / KA12-6
2 AWG		BROWN	970366438	HT41AW	900035778	U2CRT	970364786	KC12-2
1 AWG	4 AWG	GREEN	970366439	HT41AX	970570958	U1CRT	970103590	KC12-1
	4 AWG	GREEN	970366440	HT41GM	970366457	U4CABT	970364780	KA12-4
1/0 AWG	2 AWG	PINK	970366441	HT41AY	970350323	U25RT	970103635	KC12-1/0
	2 AWG	PINK	970366442	HT41GF	900035780	U2CABT	970364791	KA12-2
2/0 AWG		BLACK	970366443	HT41AZ	970345200	U26RT	970103841	KC12-2/0
3/0 AWG		ORANGE	970366444	HT41BA	970366458	U27RT	970103846	KC12-3/0
	1/0 AWG	TAN	970366445	HT41EX	970146951	U25ART	900035792	KA12-1/0
4/0 AWG		PURPLE	970366446	HT41BC	900035783	U28RT	970364795	KC12-4/0
	2/0 AWG	OLIVE	970366447	HT41EY	970189221	U26ART	900035793	KA12-2/0
250 MCM		YELLOW	970366448	HT41BE	900035784	U29RT	970364809	KC12-250
	3/0 AWG	RUBY	970366449	HT41GW	970130845	U27ART	900035794	KA12-3/0
300MCM		WHITE	970366450	HT41BF	970158508	U30RT	970103847	KC12-300
	4/0 AWG	WHITE	970252499	HT41EZ	970130842	U28ART	900035785	KA12-4/0
350 MCM		RED	970302334	HT41BJ	970119978	U31RT	970364814	KC12-350
	250 MCM	RED	970252501	HT41FW	900035786	U29ART	970103581	KA12-250
400 MCM		BLUE	970366451	HT41BK	970345201	U32RT	970103848	KC12-400
	300 MCM	BLUE	970252503	HT41GZ	970158510	U30ART	900035787	KA12-300
500 MCM		BROWN	970302332	HT41BL	900034000	U34RT	970103849	KC12-500
	350 MCM	BROWN	970252504	HT41FA	970130840	U31ART	900035788	KA12-350
600 MCM	400 MCM	GREEN	970252507 / 970366452	HT41 HH / HT41 BM	970366613 / 900050561	U32ART / U36RT	900035789 / 970103851	KA12-400 / KC12-600
	500 MCM	PINK	970179343	HT41FB	970104929	U34ART	900035795	KA12-500
750 MCM		BLACK	970366453	HT41BP	900007379	U39RT	970364817	KC12-750
	600 MCM	BLACK	970252509	HT41HG	900050561	U36ART	900035790	KA12-600
	700/750 MCM	YELLOW	970252512	HT41LJ	970104931	U39ART-2	900035796	KA12-750

COMPRESSION DIES

**POWER TOOLS
COMPRESSION DIES**

**USA: 1-877-GO ALTEC
(1-877-462-5832)**

www.alteconnect.com

HUSKIE "HT" SERIES Equivalent to Kearney "O" Type dies for 4-6 Ton Tools		KEARNEY "O" STYLE DIES for 4-6 Ton Tools		"W" STYLE DIES Equivalent to Burndy "W" Type Dies for 4-6 Ton Tools					
HUSKIE		KEARNEY		HUSKIE		BURNDY		GREENLEE	
ALTEC	HUSKIE	ALTEC	KEARNEY	ALTEC	HUSKIE	ALTEC	BURNDY	ALTEC	GREENLEE
970366496	HT-B	970087830	B (30554)	970282200	HT58AE	970280711	W-K840	970006365	KD6-13
970307899	HT-D	970045270	D (26994)	970366460	HT58BX	970366480	W-161	900001614	KD6-14
970366497	HT-J	970087832	J (48410)	970366461	HT58BZ	970366481	W-162	900010170	KD6-15
970307906	HT-K	970087834	K (40495)	970088975	HT58CB	970366482	W-163	900001616	KD6-16
900050096	HT-O	970056664	O (26993)	970366462	HT58CD	970366483	W-164	900010177	KD6-22
970366498	HT-P	970087835	P (30611)	970366463	HT58CE	900000569	W-165	970063079	KD6-17
970366499	HT-T	970087837	T (40493)	970366464	HT58CF	970366484	W-166	900010173	KD6-18
970154320	HT-737	970083109	737 (30084)	970366465	HT58CG	970075378	W-167	-	-
970366500	HT-781	970087839	781 (30450)	970366466	HT58CM	970366485	W-171	-	-
970275089	HT-840	970048203	840 (30124)	970074179	HT58G	970280715	W-BG	970026993	KD6-10
970366501	HT-316	970084210	3/16 (36181)	970366467	HT58J	970280714	W-C	900010167	KD6-12
970366502	HT-14	970048204	1/4 (30154)	970074177	HT58AK	970366486	W-O	068300116	KD6-11
970307912	HT-516	-	1/3	970282344	HT58CUT	970366495	CUTTER	-	-
970307920	HT-38	970048209	3/8 (30042)	970366468	HT58DE	970366488	W-236	-	-
970307916	HT-12	970087841	1/2 (30041)	-	-	970366489	W-237	900010179	KD6-24
970307921	HT-916	-	4/7	970366469	HT58DG	970366490	W-238	-	-
970366503	HT-1932	970043336	19/32 (30914)	970366470	HT58DH	970366491	W-239	900010180	KD6-25
970187581	HT-58-1	970048213	5/8 to 1 (26992)	970366471	HT58DK	970344509	W-241	-	-
970307922	HT-1116	970087842	11/16 (40114)	970366472	HT58DM	970366492	W-243	900010174	KD6-19
900050094	HT-D3	-	D3	970366473	HT58DP	970057447	W-245	-	-
970366504	HT-510	970095151	510 (HEX) (100600)	970366474	HT58DT	970366493	W-247	900010175	KD6-20
970325631	HT-635	970369804	635 (HEX) (100601)	970366475	HT58DV	970100610	W-248	-	-
970154322	HT-747	970095162	747 (HEX) (100602)	970366476	HT58DW	970336290	W-249	900010176	KD6-21
				970366477	HT58KA	970075376	W-687	-	-
				970366478	HT58HK	970105475	W-702	-	-
				970366479	HT58AF	970366494	W-L	-	-
				-	-	970366495	W-28K	970015446	KD6-27

"U" STYLE DIES Equivalent to ALCOA "U" Type Dies for 12 Ton Tools	
HUSKIE	
ALTEC	HUSKIE
970366521	HT4107
970366522	HT4108
970366523	HT4109
970366524	HT4111
970366525	HT4120
970366526	HT4128
970366527	HT4129
970366528	HT4130
970366529	HT4131
970366530	HT4132
970366531	HT4140
970291519	HT4141
970288718	HT4142
970366532	HT4155
970366533	HT4156
970366534	HT4180

ALCOA "U" TYPE 12 TON DIES Equivalent to HUSKIE "U" Type Dies	
ALCOA	
ALTEC	ALCOA
970366505	74SH-035SH
970366506	75SH-05SH
970366507	76SH
970366508	11AH
970366509	20AH-14AH
970366510	74AH-10AH
970366511	75AH-12AH
970366512	76AH
970366513	72AH
970366514	73AH-08AH
970366515	07CD
970366516	08CD
970366517	09CD
970366518	72SH-01SH
970366519	73SH
970366520	13AH-80EA



COMPRESSION DIES

**POWER TOOLS
COMPRESSION DIES**

USA: 1-877-GO ALTEC
(1-877-462-5832)

www.alteconnect.com



"U" STYLE DIES Equivalent to Burndy and Kearney "U" Type Dies for 12 Ton Tools					
HUSKIE		BURNDY		GREENLEE	
ALTEC	HUSKIE	ALTEC	BURNDY	ALTEC	GREENLEE
970366535	HT41G	970366583	U-BG	970098712	KD12-10
970337945	HT41J	970366584	U-C	970070859	KD12-12
970366536	HT41V	970059695	U-D	970098806	KD12-30
970258853	HT41X	970098806	U-D3	970098806	KD12-30
970237501	HT41Y	970098807	U-E	-	-
970366537	HT41Z	970366585	U-F	970098808	KD12-32
970366538	HT41AB	970366586	U-H	-	-
970366539	HT41AF	970107092	U-L	-	-
970366540	HT41AG	900096173	U-M	-	-
970210831	HT41AJ	900080002	U-N	-	-
970366541	HT41AK	970098786	U-O	970098786	KD12-11
970366542	HT41AM	970107094	U-R	-	-
970366543	HT41BX	970366587	U-161	970098788	KD12-14
970366544	HT41BZ	900016200	U-162	970098789	KD12-15
970366545	HT41CB	970086587	U-163	-	-
970366546	HT41CD	970366588	U-164	-	-
970366547	HT41CE	970001650	U-165	970365399	KD12-17
970366548	HT41CF	970366589	U-166	970098803	KD12-18
970366549	HT41CG	970366590	U-167	-	-
970366550	HT41CJ	970366591	U-168	-	-
970366551	HT41CK	970344255	U-169	-	-
970366552	HT41CL	970344256	U-170	-	-
970366553	HT41CT	970366592	U-203	-	-
970366554	HT41DE	970366593	U-236	-	-
970366555	HT41DF	970366594	U-237	-	-
970366556	HT41DG	970366595	U-238	970098810	KD12-35
970366557	HT41DH	970366596	U-239	-	-
970366558	HT41DL	970260757	U-242	-	-
970366559	HT41DM	970366597	U-243	970095674	KD12-19
970366560	HT41DP	970148554	U-245	-	-
970366561	HT41DT	970366598	U-247	970098804	KD12-20
970366562	HT41DV	970148553	U-248	-	-
970366563	HT41DW	970031469	U-249	970073265	KD12-21
970366564	HT41DY	970107091	U-251	-	-
970366565	HT41DZ	970366599	U-252	-	-
970366566	HT41EK	970005619	U-261	-	-
970366567	HT41FG	970366600	U-305	-	-
970292405	HT41FM	970086603	U-316	-	-
970366568	HT41FN	970005628	U-317	-	-
970366569	HT41FU	970075446	U-321	-	-
970366570	HT41FX	970119522	U-327	-	-
970366571	HT41GK	970366601	U-373	-	-
970366572	HT41GX	970366602	U-468	-	-
970366573	HT41HM	970063262	U-490	-	-
970366574	HT41JM	970005624	U-654	970005624	KD12-36
970366575	HT41JN	970005627	U-655	970005627	KD12-37

COMPRESSION DIES

"U" STYLE DIES Equivalent to Burndy and Kearney "U" Type Dies for 12 Ton Tools					
HUSKIE		BURNDY		GREENLEE	
ALTEC	HUSKIE	ALTEC	BURNDY	ALTEC	GREENLEE
970366576	HT41JP	970366603	U-658	970005613	KD12-38
970366577	HT41JR	970366604	U-659	970098812	KD12-39
970366578	HT41KJ	970031471	U-705	-	-
970366579	HT41LG	970114254	U-788	-	-
		970366605	U-998	970098813	KD12-40
970277792	HT41AE	970366606	UK840T	-	-
970366439	HT41AX	970570958	U1CRT	970103590	KC12-1
970366438	HT41AW	900035778	U2CRT	900035778	KC12-2
970366580	HT41AV	970366607	U3CRT	-	-
970366436	HT41AU	970189364	U4CRT	970103588	KC12-4
970366434	HT41AT	970189363	U5CRT	-	-
970366441	HT41AY	970350323	U25RT	970103635	KC12-1/0
970366443	HT41AZ	970345200	U26RT	970103841	KC12-2/0
970366444	HT41BA	970366458	U27RT	970103846	KC12-3/0
970366446	HT41BC	900035783	U28RT	900035783	KC12-4/0
970366448	HT41BE	900035784	U29RT	900035784	KC12-250
970366442	HT41GF	900035780	U2CABT	970103635 900035778	KC12-1/0 / KA12-2
970366440	HT41GM	970366457	U4CABT	970059695	KA12-4
970366437	HT41GE	970366608	U6CAT	-	-
970366435	HT41GL	970366454	U8CABT	970103570	KA12-8
970366450	HT41BF	970158508	U30RT	970103847	KC12-300
970302334	HT41BJ	970366609	U31RT	900035786	KC12-350
970366451	HT41BK	970345201	U32RT	970103848	KC12-400
970302332	HT41BL	900034000	U34RT	970103849	KC12-500
970366452	HT41BM	970366610	U36RT	970103851	KC12-600
970366453	HT41BP	900007379	U39RT	970364817	KC12-750
970366445	HT41EX	970366611	U25ART	970364814 900035792	KC12-350 / KA12-1/0
970366447	HT41EY	970189221	U26ART	900035793	KA12-2/0
970366449	HT41GW	970366612	U27ART	900035794	KA12-3/0
970252499	HT41EZ	970130842	U28ART	970103847 970364795	KC12-300 KA12-4/0
970252501	HT41FW	900035786	U29ART	970103581 970364814	KA12-250 KC12-350
970252503	HT41GZ	970158510	U30ART	900035787 970103848	KA12-300 KC12-400
970252504	HT41FA	970130840	U31ART	900035788 970103849	KA12-350 KC12-500
970252507	HT41HH	970366613	U32ART	900035789 970103851	KA12-400 KC12-600
970179343	HT41FB	970104929	U34ART	900035795	KA12-500
970252509	HT41HG	900050561	U36ART	900035790	KA12-600
970252512	HT41LJ	970104931	U39ART2	900035796	KA12-750
970220062	HT41CUT	970366615	CUTTER DIES	-	-
970366582	HT41TEST	970366616	TEST DIES	-	-

POWER TOOLS
COMPRESSION DIES

USA: 1-877-GO ALTEC
(1-877-462-5832)

www.alteconnect.com

COMPRESSION DIES

**POWER TOOLS
COMPRESSION DIES**

USA: 1-877-GO ALTEC
(1-877-462-5832)

www.alteconnect.com

HT41 SERIES Equivalent to Kearney "U" Type Dies for 12 Ton Tools	
HUSKIE	
ALTEC	HUSKIE
970366617	HT41KA
900050549	HT41KB
970366618	HT41KC
970305399	HT41KD
970366619	HT41KE
970366620	HT41KF
970366621	HT41KG
970366622	HT41KH
970366623	HT41KI
970366624	HT41KK
970293118	HT41KL
970366625	HT41KM
970255943	HT41KN
970217666	HT41KO
970366626	HT41KP
970366627	HT41KQ
970366628	HT41KR
970277802	HT41KS
970366629	HT41KT
970366630	HT41KU
970366631	HT41KV
970277792	HT41AE
970277808	HT41U
970366632	HT41KX

HT61 SERIES Equivalent to Burndy "P" Type dies for 15 Ton Tools			
HUSKIE		BURNDY	
ALTEC PART NUMBER	HUSKIE	ALTEC PART NUMBER	BURNDY
970366633	HT61BP	970366637	P39RT
970366634	HT61BR	970366638	P40RT
970049720	HT61BU	970088795	P44RT
970366635	HT61BV	970366639	P46RT
970366636	HT61KX	970366640	P724
970122871	PU15	970366641	DIE ADAPTER
970252513	HT61FC	970118842	P39ART
970252516	HT61HJ	970366642	P40ART
970049723	HT61FD	970020545	P44ART
970282635	HT61AC	970366643	PKR
970282633	HT61AJ	970224829	PN

HTK SERIES Equivalent to Kearney "WH-2" (10.7 TON) & "WH-3" (12 ton) Type Dies			
HUSKIE		KEARNEY	
ALTEC	HUSKIE	ALTEC	KEARNEY
970366658	HTK-BKT	705300768	BKT (36832)
970366659	HTK-C	705300769	C (36830)
970185597	HTK-D	705300770	D (36457)
970191672	HTK-N	705300771	N (36459)
970185598	HTK-O	818000214	O (36467)
970366660	HTK-P	705300773	P (36828)
970280966	HTK-U	970265795	U (36472)
970366644	HTK-510	705300775	510 (36838)
970366645	HTK-572	705300776	572 (36836)
970366646	HTK-635	705300777	635 (36482)
970366647	HTK-727	705300778	727 (40063)
970324815	HTK-737	705300779	737 (36480)
970366649	HTK-747	705300780	747 (36834)
970366650	HTK-781	705300781	781 (36478)
970280967	HTK-840	705300782	840 (36476)
970366651	HTK-14	705300784	1/4 (36498)
970366652	HTK-516	705300785	5/16 (36496)
970366653	HTK-38	705300786	3/8 (36494)
970366648	HTK-12	705300787	1/2 (36490)
970324831	HTK-916	705300788	9/16 (36488)
970366654	HTK-1932	705300789	19/32 (36486)
970324836	HTK-58-1	705300790	5/8 to 1 (36484)
970366655	HTK-1116	705300791	11/16 (40151)
970280970	HTK-34H	705300793	3/4 (HEX) (49435)
970324821	HTK-2932H	705300794	19/32 (HEX) (49437)
970298580	HTK-1516	970182893	15/16 (36474)
970366656	HTK-1-2H	705300796	1-2 (HEX) (100399)
970366657	HTK-1-18-2H	970024788	1-1/8 (HEX) 36463 (-1) 100400 (-2)
900050526	HTK-1-516H	970317528	1-5/16 (HEX) (100433)
970267350	HTK-1-12H	705300799	1-1/2 (HEX) (100434)

COMPRESSION DIES

POWER TOOLS
COMPRESSION DIES

USA: 1-877-GO ALTEC
(1-877-462-5832)

www.alteccconnect.com

HA60 SERIES Equivalent to Alcoa 60 Ton Dies	
HUSKIE	
ALTEC	HUSKIE
970244063	HA60-01
970325464	HA60-02
970062656	HA60-03
970203768	HA60-04
970366670	HA60-05
970366671	HA60-06
970245678	HA60-07
970245680	HA60-08
970196314	HA60-09
970243939	HA60-20
970348322	HA60-21
970366661	HA60-22
970325468	HA60-23
970366662	HA60-24
970366663	HA60-25
970366664	HA60-26
970366665	HA60-27
970245674	HA60-28
970245679	HA60-29
970196315	HA60-30
970288008	HA60-40
970243945	HA60-41
970318143	HA60-42
970366666	HA60-43
970366667	HA60-44
970063083	HA60-45
970263657	HA60-46
970325470	HA60-47
970329131	HA60-48
970366668	HA60-49
970366669	HA60-50

ALCOA SERIES 60 Ton Dies	
ALCOA	
ALTEC	ALCOA
970062651	6010SH
970062654	6012SH
970062656	6014SH
970366677	6016SH
970279462	6018SH
970062650	6020SH
970279459	6074SH
970062659	6075SH
970062660	6076SH
970062664	6020AH
970062665	6024AH
970062666	6027AH
970062669	6030AH
970062670	6034AH
970062584	6036AH
970294760	6038AH
970279467	6040AH
970062663	6074AH
970366672	6075AH
970062661	6076AH
970366673	6007CD
970062586	6008CD
970062652	6009CD
970062589	6010CD
970062590	6011CD
970062591	6012CD
970062593	6013CD
970062653	6014CD
970366674	6015CD
970366675	6016CD
970366676	6017CD

HA610 SERIES Equivalent to Alcoa 100 Ton Dies	
HUSKIE	
ALTEC	HUSKIE
970366709	HA100-01
970366710	HA100-02
970366711	HA100-03
970366712	HA100-04
970366713	HA100-05
970366714	HA100-06
970366678	HA100-07
970366679	HA100-08
970366680	HA100-20
970366681	HA100-21
970366682	HA100-22
970366683	HA100-23
970366684	HA100-24
970366685	HA100-25
970366686	HA100-26
970366687	HA100-27
970366688	HA100-28
970366689	HA100-29
970366690	HA100-30
970366691	HA100-34
970366692	HA100-36
970366693	HA100-37
970366694	HA100-38
970366695	HA100-40
970366696	HA100-41
970366697	HA100-42
970366698	HA100-43
970366699	HA100-44
970366700	HA100-45
970366701	HA100-46
970366702	HA100-47
970366703	HA100-48
970366704	HA100-49
970366705	HA100-50
970366706	HA100-51
970366707	HA100-52
970366708	HA100-53

ALCOA SERIES 100 Ton Dies	
ALCOA	
ALTEC	ALCOA
970366746	10010SH
970366747	10012SH
970366748	10014SH
970299246	10016SH
970366749	10018SH
970366750	10020SH
970366715	10074SH
970366716	10075SH
970366717	10020AH
970366718	10024AH
970366719	10027AH
970366720	10030AH
970366721	10034AH
970366722	10036AH
970366723	10038AH
970366724	10040AH
970366725	10074AH
970366726	10075AH
970366727	10076AH
970366728	10042AH
970366729	10044AH
970366730	10046AH
970366731	10048AH
970366732	10007CD
970366733	10008CD
970366734	10009CD
970366735	10010CD
970366736	10011CD
970366737	10012CD
970366738	10013CD
970366739	10014CD
970366740	10015CD
970366741	10016CD
970366742	10017CD
970366743	10018CD
970366744	10019CD
970366745	10020CD



GREENLEE®

UTILITY

A Textron Company

**POWER TOOLS
HYDRAULIC TOOLS & ACCESSORIES**

**USA: 1-877-GO ALTEC
(1-877-462-5832)**

www.alteconnect.com



HYDRAULIC IMPACT PRODUCTS

HIGH TORQUE

Designed for Professional Linemen

- Forward positioned handle for improved balance and reduced fatigue.
- Impact and heat-resistant Cool Grip™ handle+ dissipates heat.
- Large onboard lifting eye for easy and secure storage.

Upgraded Performance

- Industry-leading weight to-torque ratio.
- Quickly change between forward and reverse motions with directional control selector.
- Adjustable torque settings with variable flow knob.



HYDRAULIC IMPACT SOLUTIONS

HW1 • HW1V • HW3 • HID6506

LIGHTER DESIGNS • MORE POWER



HW1 & HW1V Impact Wrench 3/4" HIGH TORQUE

- Impact and temperature-resistant polymer grip designed to dissipate heat from the handle
- Weight reduction of 14% to previous models
- Improved center-of-gravity for superior ergonomics
- Increased service life with the addition of back-up rings and larger O-rings
- Built-in hydraulic check valve to eliminate damage from an improperly connected tool
- Large and strong lifting eye for easy and secure storage
- Longer and wider trigger provides improved control with insulated gloves
- Discrete position torque adjustment control with 3 positions; HW1V features quick-change access
- Fast, easy change between open center systems and closed center systems; no disassembly required
- Higher breaking torque in reverse to ensure you can remove tightened bolts
- Cast motor enclosure better protects the impact mechanism operation versus competing models
- HW3 features extra torque for "ripping" off old materials and drilling through utility equipment.



P/N 9703-29578 HW1 Standard Wrench (Top Left)
 P/N 9703-29580 HW1V Wrench with 3 Position Torque Control (Top Right)
 P/N 9704-91894 HW3 Wrench with Extra Torque



HW3 Impact Wrench 3/4" HIGH TORQUE

- Forward positioned handle for improved balance and reduced fatigue
 - Impact and heat-resistant Cool-Grip handle+ dissipates heat
 - Large, onboard lifting eye for easy and secure storage
 - Quickly change between forward and reverse motions with flow control selector
 - Industry-leading weight to torque ratio
 - Easily adjustable torque settings with variable flow trigger
- P/N 9704-91894 Greenlee HW3

HID6506 Rotary Impact Hammer Drill



- Percussion drilling SDS drill with quick-change chuck
- Makes 16% larger holes in concrete and 11% larger holes in wood.
- Supports speeds of up to 5,400 bpm, generating 13% more blows per minute to help you get the job done quicker
- Features an improved design for better balance and ergonomics
- Capacity: Concrete - 7/8" hole, Steel - 1/2" hole
Wood - 1-1/8" hole, Core Bit - 2-5/8"

P/N 9700-42309 Greenlee HID6506

H8508 Reversible Impact Wrench & Drill with 7/16" Hex Quick Change



P/N 7010-69023
8508-1 (Left)

P/N 8126-20300
8508-IV (Right)

- Includes (1) 1/2" HD square adapter with every wrench - a \$35 value!
- Twin-hammer impact mechanism provides high performance and reliability
- Button to switch between forward and reverse rotation.
- One-piece handle and impact housing casting provide long life.
- Super Spool™ permits quick switches between open-center and closed-center hydraulic systems
- Heat-insulated handle, ergonomically positioned for comfort.
- Well balanced for comfortable operation.
- Most durable and longest life of any 1/2" wrench on the market.
- Includes the 49314 heavy duty adapter, toughest adapter on the market.

P/N 7010-69023 H8508-1

P/N 8126-20300* H8508-IV - Adjustable Torque

P/N 360-20021 H8508-3

* Only wrench on the market with this feature!

P/N 8095-00416 H8508-3V

* Dial down torque to protect hardware



H8508 REVERSIBLE Impact Wrench & Drill

7/16" Hex Quick Change

CHOICES IN
TORQUE & SPEED

POWER TOOLS
HYDRAULIC TOOLS & ACCESSORIES

H6400C Reversible Drill, 1/2" Key-Type Chuck



- Compact, lightweight - ideal for line construction applications
- Super Spool selector control for use on open and closed center hydraulic systems
- Rugged gear motor
- Weighs 6 lbs.
- Operating pressure of 1,000 - 2,000 psi
- Flow range of 4 - 8 gpm

P/N 9000-42260 Greenlee H6400C

H6400C

ROTARY Impact Hammer Drill

1/2" Key-Type Chuck

NR1 Nut Runner

- For installing and tightening pole hardware
- Will work with 7/16" quick change chuck
- Accommodates bolts that extend up to 6" beyond the nut
- 9 1/2" long with adapter

P/N 9000-99795 45798 3/4", 13/16", 1", 1 1/8", 7/16" Hex Adapter

P/N 9000-99796 Replacement Adapter - for 3/4" Drive

NR2 Nut Runner with Adapter

- Socket can be turned end-for-end without removing the adapter from the tool
- Used for most transmission applications
- 11" long with adapter
- 1 5/16", 1 1/8", 1" square openings
- Accommodates bolts that extend up to 6" beyond the nut
- 7/16" hex adapter for use with 1/2" impact wrenches

P/N 9700-55572 20920 Nut Runner w/Adapter

P/N 9700-67360 21111 Replacement Adapter

Heavy Duty Square Adapter

- 7/16" x 1/2" drive shank
- Rated at 450 ft. lbs. of torque
- Not for use with nut runners

P/N 9000-99489 49314



NAIL EATER EXTREME BLACK UTILITY AUGER BITS

HW1 • HW1V • HW3 • HID6506

Greenlee is proud to announce our NEW Nail Eater® Extreme Black Teflon® coated Utility Auger Bits. Our new utility auger bits drill fast and smooth in most treated woods, including tough utility poles. Made in the USA, the patented cutting edge cuts nails and staples so these auger bits last much longer than other Teflon® coated bits on the market. And, with less power required to drill holes—extending battery life up to 30%—these auger bits help save time and money.

- Teflon® coating resists heat and friction for fast and smooth operation
- Patented cutting edge cuts nails and staples so the bits last longer over time
- Over center flute design evacuates chips faster, no clogging or chip flyback
- Less power required to drill holes – extending battery life by up to 30%
- Made in the USA

**...the Easier and Faster way
to drill in Utility Poles!**

Altec P/N	CAT NO.	UPC NO.	DESCRIPTION
P/N 9702-99181	66TF-9/16	02004	IMPACT AUGER BIT, TF-9/16" x 18"
P/N 9702-99183	66TF-11/16	02005	IMPACT AUGER BIT, TF-11/16" x 18"
P/N 9702-99185	66TF-13/16	02006	IMPACT AUGER BIT, TF-13/16" x 18"
P/N 9702-99187	66TF-15/16	02007	IMPACT AUGER BIT, TF-15/16" x 18"



NAIL EATER II EXTREME IMPACT BITS

Nail Eater II® Extreme Impact Bits

- Quickly bore through creosote and salt-treated utility poles
- Resists wear, eats through nails and staples
- Self-feeding screw point draws the bit through the wood
- 7/16" hex shank to fit quick-change impact drivers

P/N 9000-37868	37868	9/16" x 18"	P/N 9000-37870	37870	13/16 x 18"
P/N 9000-37869	37869	11/16 x 18"	P/N 9000-37871	37871	15/16 x 18"

Long Impact Bits

- Made from hardened alloy steel for added toughness
- Quickly bore through large creosote and salt-treated utility poles
- Self-feeding screw point draws the bit through the wood
- 7/16" hex shank to fit quick-change impact drivers
- Cutting edge can be re-sharpened multiple times and continues to self-feed

P/N 9701-87379	11097	11/16 x 24"	P/N 9701-87383	11101	13/16 x 30"
P/N 9701-87382	11100	11/16 x 30"	P/N 9701-87381	11099	15/16 x 24"
P/N 9701-87380	11098	13/16 x 24"	P/N 9701-87384	11102	15/16 x 30"

Stubby Auger Bits

- Shorter than the top competitor's bit for better access to tight spaces between studs and joists.
- Self-Feeding screw point draws bit through all wood types with less operator fatigue.
- Eliminates the need for special tools such as expensive right angle drills or multiple steps to cut the hole to size.
- Over center single flute design for cleaner holes and less splintering.
- Unique cutting edge design for fast and smooth cutting action.
- 1/4" hex quick change design for fast and easy use in all drill types.
- Clearly marked with bit diameter and catalog number on shank for easy identification.
- Perfect for drilling 2" and 4" joists.

P/N 9701-87379	11097	11/16 x 24"
P/N 9701-87382	11100	11/16 x 30"
P/N 9701-87380	11098	13/16 x 24"

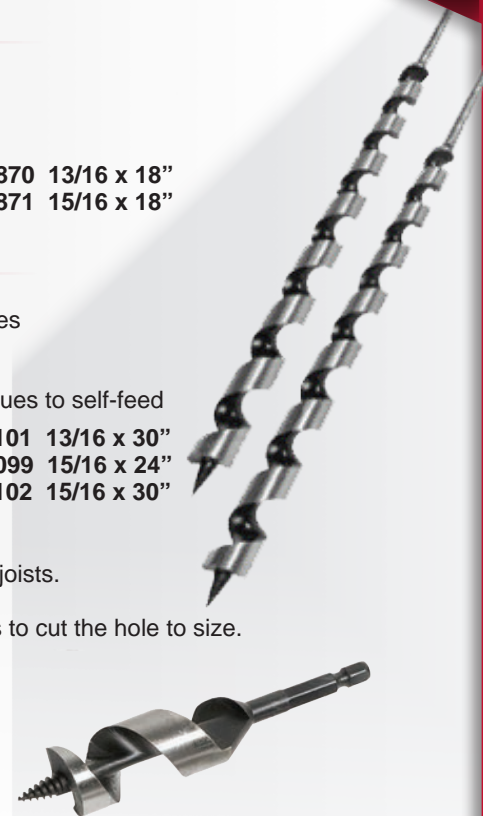



GREENLEE

UTILITY
A Textron Company

**INTELLIGENT
ERGONOMIC**

**VERSATILE
POWERFUL**

EHP700LU Power Pump Hydraulic Battery Powered Pump

The new EHP700LU 10,000 PSI battery-powered hydraulic pump sets a new benchmark for portability. During design and development, priority was given to performance, ergonomics and economic efficiency. Choose between three job specific programs: crimping, cutting and punching. The new Greenlee EHP700LU is suitable for operating single acting cutting, crimping and punching tools of up to 10,000 PSI.

MORE INTELLIGENT

- 3 in 1 program settings for crimping, cutting, punching functions
- Real-time crimp force monitoring with numeric digital display featuring IntelliCRIMP™ technology
- Audible and visual fault alert
- Real-time work history with downloadable PDF application

MORE ERGONOMIC

- The EHP700LU weighs a mere 14.1 pounds
- Padded shoulder strap included for ease of transport
- Operates in any orientation
- On-board as well as corded remote activation switches

MORE POWER

- The EHP700LU operates from a single 18V battery with on-board storage for second battery
- Pup provides real time charge status on both active and stored batteries
- 18V lithium ion (Li-ion) battery provides 70% more cycles per charge
- Available with 120V, 12V, or 230V battery charger
- Available with 120V or 230V corded adapter for stationary applications

MORE CONNECTIONS

- Connections are UL and cUL classified for copper and aluminum, when used with Greenlee tools on 7 brands of color-coded lugs and splices
- Most competitive tools are UL approved with only one connector brand



P/N	CAT NO.	DESCRIPTION
9703-90793	EHP700LU11	POWER PUMP, BAT 120V CHARGER
9703-90794	EHP700LU12	POWER PUMP, BAT 12V CHARGER
9704-00339	EHP700LU22	POWER PUMP, BAT 230V CHARGER
9704-00340	EHP700LU120	POWER PUMP, 120V ADAPTER
9704-00341	EHP700LU230	POWER PUMP, 230V ADAPTER
9704-00342	01059	HOSE ASSY, 1/4" X 6' 3/8M&3/8F FILLED
9704-00343	01058	HOSE ASSY, 1/4" X 6' 3/8M&1/4M FILLED
9704-00344	05850	HOSE ASSY, 1/4" X 10' 3/8M&3/8F FILLED
9704-00345	17707	HOSE ASSY, 1/4" X 10' 3/8M&1/4M FILLED
9704-00346	25766	ADAPTER, CHARGER 18V LI TO 12V NI
9702-16519	52176	BATTERY, 18V LI ION 3.0Ah
9702-16795	52178	CHARGER, BATTERY 120V
9702-39618	52179	CHARGER, BATTERY 230V
9702-16796	52180	CHARGER, BATTERY 12V
9702-88397	EAC18120	ADAPTER, AC - 120V TO 18V
9704-00352	EAC18230	ADAPTER, AC - 230V TO 18V
9704-00353	EL122/32	HYDRAULIC FLUID, BIODEGRADABLE
9704-00354	HTA4GL	REMOTE CONTROL
REMOTE HEADS - SINGLE ACTING REMOTE POWERED		
9706-49371	RK425	6T CRIMP TOOL - ACCEPTS EK425 JAWS
9706-49374	RK12CX	12T MULTI TOOL - ACCEPTS CCX ACCESSORIES
9706-49376	RK12ID	12T DIELESS CRIMP TOOL
9701-90442	RK1240	12T CRIMP TOOL, 42MM
9704-00359	RK1240C	12T CRIMP TOOL, 42MM, PVC COVERED
9000-05386	RK1550	15T CRIMP TOOL, C-HEAD
9704-00361	RK1550FT	15T CRIMP TOOL, FLIP TOP HEAD
9704-00356	RK06AT	6T, QUAD POINT CRIMP TOOL, OPEN HEAD DIELESS
9704-00357	RK06FT	6T QUAD POINT CRIMP TOOL, FLIP TOP HEAD DIELESS
9000-10604	RK6040	CRIMPER, 60-TON
HOSES WITH 3/8 MALE/FEMALE THREADED COUPLER		
9706-49378	NC-6-38MF	NON-CONDUCTIVE HOSE (6FT)
9705-67874	NC-10-38MF	NON-CONDUCTIVE HOSE (10FT)
9706-49408	NC-30-38MF	NON-CONDUCTIVE HOSE (10 METERS)
9704-00344	05850	CONDUCTIVE HOSE (10FT)
9704-00363	SDK105	REMOTE CABLE CUTTER - 4"
9704-00364	746	REMOTE KNOCKOUT RAM
9704-00365	750	CUTTER, CABLE HYD (750)
9706-49411	GATOR-PK	UTILITY BACKPACK

**POWER TOOLS
HYDRAULIC TOOLS & ACCESSORIES**

**USA: 1-877-GO ALTEC
(1-877-462-5832)**

www.alteccconnect.com





GREENLEE

UTILITY

A Textron Company

**POWER TOOLS
HYDRAULIC TOOLS & ACCESSORIES**

**USA: 1-877-GO ALTEC
(1-877-462-5832)**

www.alteconnect.com



LP6 6 Ton

LOW PRESSURE Hydraulic Cutting and Crimping Tool

Improved Usability

- 22% less weight versus existing competitive models

Platform Versatility

- Incorporates the same crimping and cutting jaws as Greenlee battery platform EK425L and EK628L

LPK 12 Ton

LOW PRESSURE Hydraulic Crimping Tools

Greenlee LPK1230, LPK1240, & LPK1240K crimping tools do not require a high pressure intensifier and operate on either an open or closed center hydraulic system. A relief valve signals the operator when the crimp is complete. Their crimping force at 1,500 psi is 24,000 lbs. with an operating pressure range of 1,500 - 2,500 psi. Dies and couplers are not included.



22% LESS WEIGHT

VERSATILE

Spring loaded pin for quick change over jaws

350° Rotating head aids in access to tight spaces

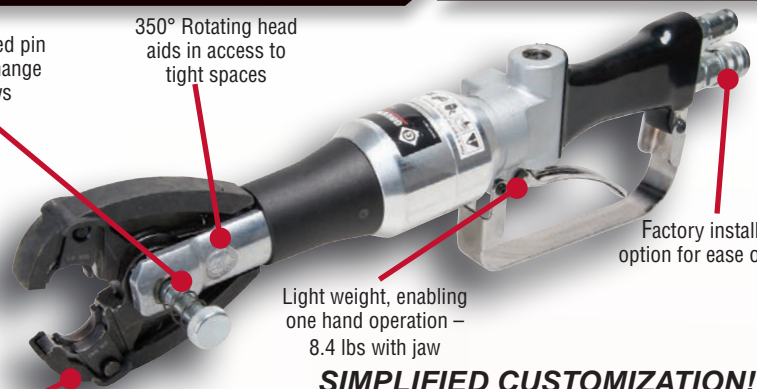

Factory installed coupler option for ease of purchase

Light weight, enabling one hand operation – 8.4 lbs with jaw

Interchangeable crimping and cutting jaws vs. competitive fixed jaw head

INTERCHANGEABLE Crimping & Cutting Jaws



CJD3BG

CJD30

CJD3



CJK



CJB



CJXPJ



SIMPLIFIED CUSTOMIZATION! Open/Closed ~ Coupler/No Coupler ~ Jaw Choice

ALTEC P/N	CAT. NO.	JAW	COUPLERS	OPEN/CLOSED CENTER
9704-00379	LP6-01	Bare	NA	OPEN
9704-00380	LP6-02	Bare	NA	CLOSED
9704-00381	LP6-03	Bare	3/4-16 SAE	OPEN
9704-00382	LP6-04	Bare	3/4-16 SAE	CLOSED
9704-00383	LP6-05	CJD3BG	NA	OPEN
9704-00384	LP6-06	CJD3BG	NA	CLOSED
9704-00385	LP6-07	CJD3BG	3/4-16 SAE	OPEN
9704-00386	LP6-08	CJD3BG	3/4-16 SAE	CLOSED
9704-00387	LP6-09	CJD30	NA	OPEN
9704-00388	LP6-10	CJD30	NA	CLOSED
9704-00389	LP6-11	CJD30	3/4-16 SAE	OPEN
9704-00390	LP6-12	CJD30	3/4-16 SAE	CLOSED
9704-00391	LP6-13	CJD3	NA	OPEN
9704-00392	LP6-14	CJD3	NA	CLOSED
9704-00393	LP6-15	CJD3	3/4-16 SAE	OPEN
9704-00394	LP6-16	CJD3	3/4-16 SAE	CLOSED
9704-00395	LP6-17	CJK	NA	OPEN
9704-00396	LP6-18	CJK	NA	CLOSED
9704-00397	LP6-19	CJK	3/4-16 SAE	OPEN
9704-00398	LP6-20	CJK	3/4-16 SAE	CLOSED

LPK1230



- 1.20" jaw opening
- Compatible with dies for Burndy Y35, Alcoa 12A, 12AC, 12HA, 12HAC; Anderson HC-12, HC-12H
- Accepts standard "U" style dies
- Flow range of 3-9 gpm
- 18.5 lbs.

P/N 9000-42184 LPK1230

LPK1240



- 1.65" jaw opening
- Flow range of 3-9 gpm
- Crimps up to 750 MCM copper and aluminum
- Compatible with dies for Burndy Y35, Alcoa 12A, 12AC, 12HA, 12HAC; Anderson HC-12, HC-12H, Thomas & Betts 12-ton
- 19.7 lbs.

P/N 9000-49345 LPK1240

LPK1240K



- Compatible with dies for Kearney PH-2 and PH-3 tools
- Flow range of 3-9 gpm
- 19.5 lbs.

P/N 9000-48735 LPK1240K

15 TON CRIMPING TOOL



LPK1550
15 TON Crimping Tool



P/N 9700-86937

- No high pressure intensifier required
- Crimps cable 500 MCM and larger
- Dies and couplers not included
- 1,500 - 2,500 psi
- Flow range of 3-9 gpm
- Operates on either open or closed center hydraulic systems
- Relief valve signals operator when crimp is complete
- Compatible with dies for: Kearney PH2*, PH4/PH14; Burndy Y35*, Y46*; Penn-Union TPU-15PH*; Thomas & Betts TBM15PF*
- May be converted (with adapters) for use with Burndy "U" style dies and Kearney PH2 and some WH2 dies

P/N 9000-48750 Greenlee LPK1550*

Die Adapters:

P/N 9000-48820	48820	Burndy Y46, Penn-Union TPU 15BH
P/N 9700-98617	48788	Thomas & Betts TBM 15PF
P/N 9700-86937	48802	12 Ton U-Die
P/N 9000-48824	48824	Kearney PH2

*Requires adapter



UTILITY
A Textron Company



**LPK
1550**
15 Ton
**LOW PRESSURE
Hydraulic
Crimping Tool**

**POWER TOOLS
HYDRAULIC TOOLS & ACCESSORIES**

USA: 1-877-GO ALTEC
(1-877-462-5832)

www.alteccconnect.com

60 TON CRIMPING TOOL



- Accepts Burndy "L" dies and Alcoa "6000 Series" crimping dies
- After completing the connection, the top of the head easily swivel 90° and can be lifted from the tool to remove the connector
- Removing the tool from the stand exposes a lifting eye for when the tool must be used above ground level
- P/N 9000-10604 requires 10,000 psi single-acting hydraulic power source
- P/N 9702-12113 requires 10,000 psi double acting hydraulic power source
- Equipped with 3/8" male type hydraulic couplers
- Includes steel carrying case with storage space for dies
- Crimping force at 10,000 psi is 120,000 lbs.

P/N 9000-10604	RK6040	Single Acting (Shown)
P/N 9702-12113	DK6040	Double Acting



RK
60 Ton

DK
60 Ton



**Altec
Supply**

POLE TAMPERS

H4802 Pole Tampers & Accessories

- Makes quick work of setting poles, asphalt patch, and general construction backfill compacting
- Reversible on/off valve allows tamper to be used with an open or closed center hydraulic system
- Comes with standard kidney-shaped foot
- Only 3 moving parts for low maintenance
- Kidney shaped foot (P/N 9000-40301) standard
- Flow range of 4 - 6 gpm
- Operating pressure of 1,000 - 2,000 psi

Pole Tampers with Hose End Valve (Shown Left):

P/N 8930-00400 Greenlee H4802 60" long
 P/N 8930-20500 Greenlee H4802-1 85" long
 P/N 360-30021 Greenlee H4802-6 60" long; no valve

Pole Tampers with Valve on Tube (Shown Right):

P/N 9000-42200 Greenlee H4802-5 60" long
 P/N 7010-69084 Greenlee H4802-3 72" long



SIGN POST DRIVER & POLE PULLER

HPD Series Sign Post Driver



P/N 9000-11183

- Can drive a variety of post sizes from small delineator posts up to 3 1/2" round posts including square, "U" channel, breakaway stubs, round, "T" fence, and wood
- Quick change front head design accommodates adapters for different types of posts
- Dual guide handles provide directional control
- A deep post opening and smooth operation ensures that the driver will not jump off of posts
- Flow range of 5-8 gpm
- 75 lbs. with UA adapter, hoses
- 1,500 - 2,000 psi operating pressure
- 9/16-18 SAE O-ring Boss; 1/2" NPTF
- Can be used with open and closed center hydraulic systems
- Available with integral trigger or remote on/off valve

P/N 9000-11183 HPD-T-U/11183 Internal Trigger; Universal Post Adapter

P/N 8095-00274 HPD-HV-U/11186 Remote On/Off Valve; Universal Post Adapter

Sign Post Driver Accessories

P/N 9000-49532 UA/49533 Universal head adapter
 P/N 9000-49533 RA96/49532 3.8" round head adapter
 P/N 9000-49534 SA54/49534 2 1/8" square head adapter

Sign Post Pole Puller

- Uses serrated jaws or wrap-around, high strength alloy chain
- Able to pull nearly any post size and shape
- Faster and easier than conventional manual methods
- Open center hydraulic system
- Lifting capacity of 9,800 lbs.
- Flow range of 4 - 6 gpm
- Operating pressure of 1,000 - 2,000 psi
- Weighs 70 lbs.
- 5" stroke
- 9/32" alloy chain

P/N 9000-42237 H4905A/42237



HYDRAULIC EQUIPMENT

GREENLEE GROUND ROD DRIVERS

HRD-1 & HRD 58 Ground Rod Drivers

- Flow range of 5 - 8 gpm
- Maximum input pressure 2,000 psi
- Accommodates various sizes of ground rods
- May be used with single or stacked rods
- May be used on an open or closed center system
- Drivers come with built in dual carrying handles and a lifting eye

P/N 9000-11192 Greenlee HRD-58
P/N 9000-11193 Greenlee HRD-1



HYDRAULIC ROCK DRILL HRD44A Rock Drill



- Weighs 44 lbs.
- Drills holes up to 2 1/2" diameter, 10' deep
- Vibration isolated and cushioned handles reduce operator fatigue
- Uses bits with 7/8" x 4 1/4" shanks
- On board air compressor provides air to clean dust out of holes
- Drill rotation speed is adjustable from 0 to 400 rpm with a 4 positioning dial; tool can be operated without rotation
- Supplied with steel braided whip hoses

P/N 9000-00944

Greenlee HRD44A

HYDRAULIC POLE PULLER H4910A Pole Puller

- Pole puller works in confined areas, next to buildings, or out in the open
- Lifting capacity of 56,000 lbs.
- Designed for heavy-duty construction
- May be used on either an open or closed-center hydraulic system
- Comes standard with a 5/8" proof-certified 6' alloy chain
- Flow range of 4 - 15 gpm
- Operating pressure of 300 - 2,800 psi

P/N 7010-69005 Greenlee H4910A



POWER TOOLS

USA: 1-877-GO ALTEC
(1-877-462-5832)

www.alteconnect.com

PAVING BREAKERS

POWER TOOLS
HYDRAULIC TOOLS & ACCESSORIES

USA: 1-877-GO ALTEC
(1-877-462-5832)

www.alteconnect.com

HPB25 25 Lb. Paving Breaker



- "D" handle and an assist handle for both vertical and horizontal operation
- Simple construction with few parts provides easy maintenance and excellent durability
- Supplied with steel braided whip hoses
- Hydraulic cushioning of the ram return stroke helps to reduce operator fatigue
- Lever style latch for quick tool changes
- Open center system
- 7/8" x 3 1/4" chuck size
- Hydraulic flow of 3-7 gpm
- 1,280 - 1,850 psi operating pressure
- Maximum pressure of 3,000 psi
- 1,800 blows per minute at 5 gpm
- Whip hoses are 3/8" NPTF x 12"

P/N 9000-49537 Greenlee HPB25

HPB35 35 Lb. Paving Breaker



- Vibration isolated and cushioned handles to reduce operator fatigue
- Simple construction with few parts provides easy maintenance and excellent durability
- Supplied with steel braided whip hoses
- Hydraulic cushioning of the ram return stroke helps to reduce operator fatigue
- Lever style latch for quick tool changes
- Open center system
- 1" x 4 1/4" chuck size
- Hydraulic flow of 5-8 gpm
- 2,000 blows per minute at 7 gpm
- Whip hoses are 3/8" NPTF x 12"
- 1,140 - 1,700 psi (3,000 psi max.) operating pressure

P/N 9000-49538 Greenlee HPB35

HPB45 45 Lb. / HPB55 55 Lb. Paving Breakers

- Great for breaking sidewalks and curbs or driving ground rod, and for other small demolition jobs
- Clean modular design with few protrusions to irritate operators' legs
- High blow energy provides maximum breaking power
- Integral rubber damper reduces chisel noise
- Low noise and vibration levels
- AVS tools have patented spring-dampened handles that reduce vibration transmitted to the operator by 80%-90%
- Two-step trigger
- Supplied with 12" steel braided whip hoses
- Open center hydraulic system
- 1/2" BSP pressure and return ports; 1/2" NPTF x 12" whip hoses

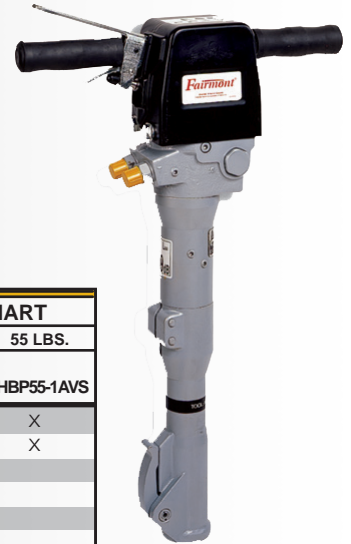

				BREAKER COMPATIBILITY CHART				
				25 LBS.	35 LBS.	45 LBS.		55 LBS.
ALTEC P/N	CAT. #	UPC #	DESCRIPTION	HPB25	HPB35	HBP45-1AVS	HBP45-2AVS	HBP55-1AVS
9000-41706	FO18451	41706	Moil Point - 1 1/8 x 6"			X		X
9000-41707	FO18452	41707	3" Chisel - 1 1/8 x 6"			X		X
9701-05048	49138	49138	Moil Point - 1 x 4 1/4"		X		X	
9701-05050	46219	46219	3" Chisel - 1 x 4 1/4"		X		X	
9701-05051	46221	46221	Asphalt Cutter - 1 x 4 1/4"		X		X	
9700-61015	46222	46222	5/8" Threadless Ground Rod Adapter - 1 x 4 1/4"		X		X	
9700-68906	46223	46223	1" Threadless Ground Rod Adapter - 1 x 4 1/4"		X		X	
9701-05054	FO16769	41610	Moil Point - 7/8 x 3 1/4"	X				
9701-05055	FO16770K	41611	3" Chisel - 7/8 x 3 1/4"	X				
9700-97334	113509	40349	1" Threadless Ground Rod Adapter - 7/8 x 3 1/4"	X				
9700-99373	137449	41070	5/8" Threadless Ground Rod Adapter - 7/8 x 3 1/4"	X				

Altec P/N	Greenlee P/N	Tool Shank Size	Sound Power Level	Blow Energy	Blow Frequency	Oil Flow	Operating Pressure
P/N 9000-02197	HPB45-1AVS*	1 1/8" x 6" AVS	110 dB	63 ft-lbs.	2160/minute	5-8 gpm	1500-1800 PSI
P/N 9000-02198	HPB45-2AVS*	1" x 4 1/4" AVS	109 dB	63 ft-lbs.	2160/minute	5-8 gpm	1500-1800 PSI
P/N 9000-02201	HPB55-1AVS*	1 1/8" x 6" AVS	112 dB	81 ft-lbs.	1860/minute	5-8 gpm	1500-1800 PSI

* Cushioned, spring-dampened handles

SUBMERSIBLE PUMPS

Submersible Pump



- Compact, lightweight design
- High impact strainer housing
- Up to 275 gpm
- Carrying handle
- Can draw water down to depth of 1 3/4"
- Can run dry without damage
- Open and closed center systems

P/N 9700-98349

H4665A

2 1/2" Submersible Pump



- High impact strainer housing
- Up to 400 gpm
- Carrying handle
- Self priming
- Can run dry without damage
- Open and closed center systems
- Can draw water down to depth of 2"

P/N 9000-42190

H4660B

3" Submersible Pump



- Lighter than typical 3" water pumps
- Lightweight, durable all-aluminum body
- 12" diameter to fit in compact areas
- Self-priming submersible pump
- Can run dry without damage
- Open and closed center operation runs off of a variety of power sources
- Passes up to 3" solids, minimizing pump blockage from debris
- Draws water down to depth of 2 3/4"
- Locking coupler for discharge hose included

P/N 9000-49334

H4635

4" Submersible Pump



- No clog, self priming, abrasion resistant impeller pump
- Up to 900 gpm
- Replaceable wear plate, carry handle
- Can run dry without damage
- 4" NPT discharge, will pass 3" solids
- Open and closed center systems
- Draws water down to depth of 3 1/4"
- Locking coupler for discharge hose included

P/N 9000-42192

H4670

Greenlee Submersible Pump Specifications

	Intake Port	Discharge Port	Width	Height	Flow Range	Operating Pressure	Pressure Port Thread	Return Port Thread
8095-00274	1 5/16"	2" NPFT	7.5"	12.5"	5-8 gpm	0 - 2,000 psi	9/16 -18 SAE O-Ring	3/4 - 16 SAE O-Ring
9000-42190	1 1/2"	2.5" NPT	12"	16"	4-8 gpm	0 - 2,000 psi	9/16 -18 SAE O-Ring	3/4 - 16 SAE O-Ring
9000-49334	3.125"	3" Female NPT	11.87"	14.18"	8-10 gpm	0 - 2,000 psi	1/2" Male NPTF	1/2" Male NPTF
9000-42192	4" NPT	4" NPT	14.5"	15.75"	5-9 gpm	0 - 2,000 psi	1/2" Male NPTF	1/2" Male NPTF

Submersible Pump Accessories - Discharge Hoses/Couplings



P/N 9000-41220

Part Number	Greenlee	Hose Assembly
9000-41220	156340	2" Diameter x 25' Discharge Hose Assembly for use with Submersible Pump P/N 9700-98349
9700-17027	F024772	2" Cam Lock Coupling for Discharge Hose P/N 9000-41220
9000-41219	156339	2.5" Diameter x 25' Discharge Hose Assembly for use with Submersible Pump P/N 9000-42190
9000-42105	F024775	2.5" Cam Lock Coupling for Discharge Hose P/N 9000-41219
9000-49499	49499	3" Diameter x 25' Discharge Hose Assembly for use with Submersible Pump P/N 9000-49334 and P/N 9000-49334
9000-41189	41189	4" Diameter x 25' Discharge Hose Assembly for use with Submersible Pump P/N 9000-42192

P/N 9700-17027



HYDRAULIC EQUIPMENT

POWER TOOLS
HYDRAULIC TOOLS & ACCESSORIES

USA: 1-877-GO ALTEC
(1-877-462-5832)

www.alteconnect.com

Long Reach Chain Saw

- Designed for use from aerial platforms or the ground
- The insulated fiberglass extension tubes are tested to meet OSHA regulation 1910.269
- Operating pressure: 1,000 - 2,000 psi
- Chain size of 0.325" pitch; cut capacity of 13"
- Safety features include a two-step trigger, a trigger guard, a fully covered sprocket guard, anti-kickback chain, and an automatic chain oiler
- Super Spool™ selector control allows chain saws to be used on both open and closed center systems
- Flow range of 5-8 gpm

P/N 7010-69018 43178 62.5" long
P/N 9000-38568 38568 75.0" long
P/N 7010-69017 43177 88.5" long

82" Overhead Circular Saw

- Designed for high production utility line clearing and general tree clearing applications
- Features hand stop safety collar, trigger guard, two step safety trigger, branch stop
- Insulated fiberglass extension tube meets OSHA 1910.269
- 82" long with angular head design
- 9" blade diameter with cut capacity of 3.5"
- 1,000 - 2,000 psi; 4-6 gpm flow range
- Operates on open or closed center systems

P/N 7010-69155 43180 Overhead Circular Saw
P/N 9000-42853 L088009 9" Blade
P/N 9000-43973 43973 9" Chain Blade

86" Utility Pruner

- The insulated fiberglass extension tubes are tested to meet OSHA regulation 1910.269
- Operating pressure: 1,000 - 2,000 psi
- Designed for utility line clearing and selective pruning of shade trees
- Heavy cut capacity cuts branches up to 2"
- Trigger guard
- Flow range of 4-6 gpm
- Heat insulated handle; full power return

P/N 7010-69149 48520 Open Center

60" Orchard/Shade Tree Pruner

- Heavy duty large capacity pruner; only 7.7 lbs.
- 360° swiveling extension
- Operating pressure: 1,000 - 2,000 psi
- Cutting capacity of 1 3/4"
- Flow range of 4-6 gpm
- Open center with and aluminum extension type
- Not to be used near high voltage lines

P/N 9000-42909 LHFS-210003



HYDRAULIC EQUIPMENT

Standard Chain Saws



- Ideal for large trimming applications and cut-up removal jobs
- Reduced kickback bar, chain
- Rugged gear motor and expanded chip exit area
- Super Spool™ selector control for open and closed center systems
- The handle position on these saws can be oriented to horizontal, or to 60° or 30° relative to bar and chain according to operator preference
- Safety features on these saws include: two-step safety trigger, high impact polymer front handle/shroud, wide lower handle protects hands/knuckles, chain catcher stops chain rotation
- Automatic chain oiler can be adjusted without tools
- Supplied with 12" steel braided whip hoses (couplers not included)
- Chain pitch of 3/8"; cut capacities range from 16" - 24"
- Flow range of 4 - 8 gpm; operating pressure: 1,000 - 2,000 psi

P/N 9000-49566	HCS816	16"
P/N 9700-51929	55141	16" Replacement Bar
P/N 9700-12295	41960	Replacement Chain Size 16" x .050"
P/N 9000-49603	HCS820	20"
P/N 9702-14216	55185	20" Replacement Bar
P/N 9000-55191	55191	Replacement Chain Size 20" x .050"



Pistol-Grip Chain Saw

- Ideal for cutting back or trimming from an aerial basket
- Reduced kickback bar and chain
- Rugged gear motor and expanded chip exit area
- Super Spool™ selector control for open and closed center systems
- Automatic chain oiler can be adjusted without tools
- Handle position can be oriented to horizontal, or to 60° or 30° relative to bar and chain according to operator preference
- Safety features on these saws include: two-step safety trigger, high impact polymer front handle/shroud, wide lower handle protects hands/knuckles, chain catcher stops chain rotation

- Includes 12" steel braided whip hoses (couplers not included)
- Sprocket cover is removed without tools for easy cleaning
- Chain, bar are adjustable without removing sprocket cover
- Chain pitch of .325"; cut capacity of 13"
- Flow range of 4 - 8 gpm; operating pressure of 1,000 - 2,000 psi

P/N 9000-49565	HPS513	
P/N 9706-40807	F030030	Chain 13" x .058"
P/N 9000-43369	43369	13" Replacement Bar

HYDRAULIC EQUIPMENT

POWER TOOLS
HYDRAULIC TOOLS & ACCESSORIES

USA: 1-877-GO ALTEC
(1-877-462-5832)

www.alteconnect.com

F13 Portable Hydraulic Power Unit With Adjustable 5-8 gpm Hydraulic Oil Flow

- Easy pull recoil start and dependable Honda 4-stroke OHV GX390 gasoline engine
- Low oil alert and shutdown protection system
- The engine is CARB (California Air Resources Board) certified as well as compliant with upcoming 2011 EPA emissions standards
- Constructed with a durable, powder-coated, welded steel tubular frame protects the engine, fan cooled oil cooler and oil reservoir, while providing easy access to all service points
- Oversized fan cooled oil cooler increases run time, tool performance, operator comfort and overall system reliability
- Large 13" diameter by 3" wide no-flat tires ensure easy job site handling and transport over a wide variety of surfaces and soils
- Quick-release telescoping handles
- Hydraulic oil-level site gauge
- Supplied with HTMA flat-faced couplers and a 25-micron return line filter
- Easy access to all operation and service points



P/N 9000-49618 F13 (31378)

SPECIFICATIONS	
Horsepower	13 at 3,600 rpm (9.7 kW at 3,600 rpm)
System	Open-Center
Rated Flow	5 - 8 gpm (19 - 30 lpm)
Rated Pressure	2,000 psi (138 bar)
Sound Power Level	LWA = 101 dB
Fuel	Gasoline 1.7 gal (6.5 l)
Hydraulic Oil Capacity	1.8 gal (7.0 l)
Dry Weight*	168 lb (76 kg)
Length (handles retracted)	28" (710 mm)
Width	23.5" (597 mm)
Height	25.5" (648 mm)

High Pressure Couplers



P/N 9703-57700 P/N 9000-40652 P/N 9000-41877



P/N 9000-40647 P/N 9000-41941 P/N 9000-42096

- | | | |
|----------------|-------|---|
| P/N 9000-40647 | 40647 | Male Coupler, nose half
1/4 - 18 NPSM |
| P/N 9000-40652 | 40652 | Female Coupler 1/4 - 18 NPSM |
| P/N 9703-57700 | 54169 | Male Coupler, nose half
1/4 - 18 NPTM (Used on HB10) |
| P/N 9000-42096 | 42096 | Female Coupler 1/4 - 18 NPTM
(Used on HB10) |
| P/N 9000-41941 | 41941 | Male Coupler, nose half
3/8 - 18 NPTF |
| P/N 9000-41877 | 41877 | Female Coupler 3/8 - 18 NPTM |

HYDRAULIC EQUIPMENT

POWER TOOLS

**USA: 1-877-GO ALTEC
(1-877-462-5832)**

www.alteconnect.com

HFC30 Flow Control Valve



- Operates off other equipment's hydraulic accessory circuit
- Variable flow adjustment (up to 30 gpm) allows precise flow control for tool operation
- Integral pressure relief valve helps protect hydraulic equipment and tools
- All tool ports have O-Ring boss

and accept industry standard hoses and couplers

- All-aluminum body design provides better heat dissipation

P/N 9701-02585 HFC30

PVA Valves



- Controlled advance; 4-way, 3 position valve
- 3-8 gpm flow range
- Built-in hold feature
- May be directly connected to the tool or used remotely with hoses
- 3,000 - 4,000 psi return line ground dump safety valve
- Maximum operating pressure: 10,000 psi return relief
- Port size inlet: 1/4 - 18 NPTF; Tool: 1/4 - 18 NPSM

P/N 9000-99682 PVA0021 For Single Acting Tool (Top)

P/N 9000-22396 PVA0022 For Double Acting Tool

P/N 0021-00072 PVA1122 For Coupled Double Acting Tools

Dynapress Hydraulic Intensifier

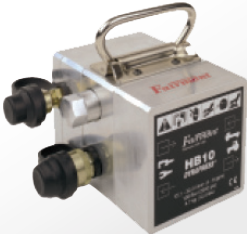

- Small and compact, the HB10 operates 10,000 psi remote head tools
- Operates on open or closed center hydraulic systems
- Uses the versatile Dynapress remote control valves and hoses sets
- Supplied with pressure and

return high pressure screw-type couplers (HTMA couplers available)

- Crimping at 10,000 psi is 120,000 lbs.
- Fast advance flow of 3,200 cubic inches per minute

	<i>Specifications</i>			
	<u>Input Pressure</u>	<u>Input Flow</u>	<u>Max. Back Pressure</u>	<u>Port Sizes</u>
<i>Low Pressure</i>	1,000-2,200 psi	4 - 8 gpm	200 psi	3/4 - 16 SAE O-ring
	<u>Output Pressure</u>	<u>Output Flow</u>	<u>Relief Valve Setting</u>	<u>Port Sizes</u>
<i>High Pressure</i>	10,000 psi	35 cu.in./min	10,000 psi	1/4 - 18 NPSM*

P/N 9000-49830 Greenlee HB10

P/N 7162-01070 Platform Holder for the Greenlee HB10

High Pressure Non-Conductive Hose



- Certified Non-conductive High Pressure Dual Hose Set - Rated 10,000 psi (700 bar)
- For use between Dynapress® intensifier or electric pump and control valve
- Each pair includes 3/16" (4.8 mm) I.D. pressure hoses with one 1/4" NPT male fitting on one end and high-pressure quick-disconnect on the other end
- Hoses are tested at 75kV per foot

P/N 9000-30694 138573/41107 6 ft.

P/N 9700-19302 138574/41108 10 ft.

- Certified Non-conductive High Pressure Hose - Rated 10,000 psi (700 bar)

- For use between control valve and tool

- 3/16" (4.8 mm) I.D. hose with 1/4 NPT male fittings on both ends.

P/N 9000-41795 F020721/41795 6 ft.

P/N 9700-14174 F020723/41796 10 ft.



LPHY750XT KOMPRESSOR™

Remote Operated 12 Ton Low Pressure Tool

- Industry exclusive visual crimp indicator assures properly completed crimps with 12 tons of force
- Covers a wide range of applications with its 1.65" jaw opening
- Fast crimp technology
- Use all standard BURNDY® "U" dies
- 350° head rotation for versatile tool head positioning allows getting into tight areas easier
- Operates on open or closed center hydraulic systems
- Ergonomic handle design for better balance and helps lessen fatigue
- Double acting tool for hydraulic ram advance and retraction
- Industry exclusive spring back up for ram retraction if hydraulic system shuts down
- Flow Range: 3-9 GPM; 1500-2500 psi Operating Pressure
- Approximately 2 second crimp time
- Conductor range #8-750 kcmil Al/Cu



P/N 9702-16402 LPHY750XT

ENFORCER® HIW716ENF

Hydraulic Impact Wrench 7/16"



- Industry exclusive dual torque selector spool allows switching between 200 and 515 ft-lbs of output torque
- 7/16" Tri-ball quick change chuck
- CNC machined from high strength billet aluminum for tighter tolerancing, ensuring higher quality
- Weighs less than 6 lbs - Lightest hydraulic impact wrench in its class
- Features "feathering" ability - easing up to a certain torque level
- Max. Output Torque: 515 ft-lbs; Flow Range: 4-12 GPM
- Cartridge style valves provide outstanding wear characteristics as well as economical and easier servicing
- Dual spool allows for selecting between open and closed center hydraulic systems (located in the handle); factory set at open
- Secure positioning and a wide flange makes changing from auger bits to sockets or other hardware adaptors a breeze
- Weight: 5.95 lbs; Length: 7.8"; Height: 8.9"; Width: 3.1"

P/N 9702-03368 HIW716ENF ENFORCER®

HIW716MAG IMPACT WRENCH

MAG Series, Hydraulic Impact Wrench - Machined Aluminum Gerotor Design



- Aircraft grade extruded aluminum body, forged handle
- CNC machined parts
- Frictionless gerotor motor
- Cartridge style valve
- 7/16" Tri-ball quick change chuck
- Dual Spool selector for Open & Closed Systems
- "Glove-sized" wide grip activation trigger
- Inlet/Outlet SAE 6 adapters
- Reverse flow and hook-up protection
- Injection molded thermally insulated textured comfort grips
- Forward / Reverse selector



**MAGHOLSTER
(TOOL SOLD SEPARATELY)**

P/N 9702-03368	HIW716MAG	Hydraulic Impact Wrench
P/N 9706-37135	HIW716MAGKIT1	Hydraulic Impact Wrench with Flat Face Couplers
P/N 9706-37136	HIW716MAGKIT2	Hydraulic Impact Wrench with Swivels, 8' NCR Hose and Flat Face Couplers
P/N 9706-37137	HIW716MAGKIT3	Hydraulic Impact Wrench with Swivels, 10' NCR Hose and Flat Face Couplers
P/N 9706-37138	HIW716MAGKIT4	Hydraulic Impact Wrench with Flat Face Couplers and Trigger Guard
P/N 9706-37139	HIW716MAGKIT5	Hydraulic Impact Wrench with Flat Face Couplers, Trigger Guard, and Assist Handle
P/N 9706-40808	MAGHOLSTER	Holster for Hydraulic Impact Wrench

DOMINATOR AUGER BITS



- Aggressive lead screw and cutting face feeds through the toughest of utility poles
- Heat treated cutting faces, lead screw and shank - increased hardness for extended life
- Bevelled head acts as reverse thread to provide quicker, easier extraction from pole
- Designed for treated wood
- Hardened Steel Tip
- Self-feeding
- 100+ approximate holes drilled per bit

Altec Number	BURNDY Number	Length	Hole Dia
P/N 9702-98039	LPHTBIT5818D	18"	5/8"
P/N 9702-98022	LPHTBIT111618D		11/16"
P/N 9702-98041	LPHTBIT3418D		3/4"
P/N 9702-98043	LPHTBIT131618D		13/16"
P/N 9706-37140	LPHTBIT7818D		7/8"
P/N 9702-98044	LPHTBIT151618D		15/16"
P/N 9706-37141	LPHTBIT5824D		24"
P/N 9702-98045	LPHTBIT111624D	11/16"	
P/N 9706-37142	LPHTBIT3424D	3/4"	
P/N 9702-98047	LPHTBIT131624D	13/16"	
P/N 9702-98048	LPHTBIT151624D	15/16"	
P/N 9706-37143	LPHTBIT11824D	1-1/8"	

RAZOR AUGER BITS



- Designed for treated wood
- Hardened Steel Tip
- Self-feeding
- Single Flute
- Added Spur
- Aggressive lead screw
- Fast Drilling
- Extra clean holes
- No re-drilling required
- 100+ approximate holes drilled per bit

Altec Number	BURNDY Number	Length	Hole Dia
P/N 9706-37144	LPHTBIT9168R	8"	9/16"
P/N 9706-37145	LPHTBIT91618R	18"	9/16"
P/N 9706-37146	LPHTBIT5818R		5/8"
P/N 9706-37147	LPHTBIT111618R		11/16"
P/N 9706-37148	LPHTBIT3418R		3/4"
P/N 9706-37149	LPHTBIT131618R		13/16"
P/N 9706-37150	LPHTBIT151618R		15/16"
P/N 9706-37151	LPHTBIT111624R		24"
P/N 9706-37152	LPHTBIT131624R	13/16"	
P/N 9706-37153	LPHTBIT151624R	15/16"	
P/N 9706-37154	LPHTBIT11824R	1-1/8"	

ELIMINATOR™ AUGER BITS



- Designed for treated wood
- Carbide Tip
- Single Flute
- Patented Cutting Geometry
- Fast Drilling
- Very clean holes
- Easy fastener insertion
- Lowest cost per hole drilled
- Can be refurbished
- 2000+ approximate holes drilled per bit

Altec Number	BURNDY Number	Length	Hole Dia
P/N 9706-37155	LPHTBIT1218	18"	1/2"
P/N 9706-37156	LPHTBIT111618		11/16"
P/N 9706-37157	LPHTBIT131618		13/16"
P/N 9706-37158	LPHTBIT151618		15/16"
P/N 9706-37159	LPHTBIT131624	24"	13/16"

HOLLOW CORE AUGER BITS



- Designed for fiberglass and composites
- Carbide Tip; Engineered cutting tip
- Specialized short flute
- "Solid" body design
- Cuts quickly and cleanly
- No splinters; No melting
- Drill both holes at once
- Can be re-sharpened
- 500+ approximate holes drilled per bit

Altec Number	BURNDY Number	Length	Hole Dia
P/N 9706-37160	LPHTBIT91612HC	12"	9/16"
P/N 9706-37161	LPHTBIT111612HC		11/16"
P/N 9706-37162	LPHTBIT131612HC		13/16"
P/N 9706-37163	LPHTBIT11812HC		1-1/8"
P/N 9706-37164	LPHTBIT111618HC	18"	11/16"
P/N 9706-37165	LPHTBIT131618HC		13/16"

SOLID CORE AUGER BITS



- Designed for fiberglass and composites
- Carbide Tip; Engineered cutting tip
- Specialized long flute
- "Fluted" body design
- Cuts quickly and cleanly
- No splinters, No melting
- Removes debris quickly
- Drill both holes at once
- Can be re-sharpened
- 500+ approximate holes drilled per bit

Altec Number	BURNDY Number	Length	Hole Dia
P/N 9706-37166	LPHTBIT111612SC	12"	11/16"
P/N 9706-37167	LPHTBIT131612SC		13/16"
P/N 9706-37168	LPHTBIT131618SC	18"	13/16"

POWER TOOLS
HYDRAULIC TOOLS & ACCESSORIES

USA: 1-877-GO ALTEC
(1-877-462-5832)

www.alteconnect.com



POWER TOOLS
HYDRAULIC TOOLS & ACCESSORIES

USA: 1-877-GO ALTEC
(1-877-462-5832)

www.alteconnect.com

Y60LW HYPRESS™

Lightweight 60 Ton Hydraulic Crimp Tool



- Portable, lightweight design — 43 pounds - with side lift handle
- Heavy duty hoisting loop
- Single acting ram with heavy duty return spring
- Upper die cap securely locks to a positive detent position for safe operation
- Large jaw opening accommodates variety of conductor types
- Single acting, lightweight 60 ton HYPRESS™ designed to install transmission and distribution connectors and sleeves
- Uses BURNDY® "L" and wide "L" style dies
- Protected male coupler has unrestricted access, making tightening easier
- Portable for easy maneuverability and will operate from any 10,000 psi hydraulic source with the proper oil capacity

P/N 9703-89692 Y60LW
 P/N 9703-89693 Y60LWLS
 P/N 9706-37169 Y60LWCASE

Tool Head with Stand, Metal Case
Tool Head without Stand
Case, Fits Tool Head Only

GP10 GASOLINE POWERED

10,000 PSI Hydraulic Pump



- Hydraulic output pressure of 10,000 psi
- Portable pump with sturdy steel roll cage
- Durable heavy-duty four (4) HP engine for all HYPRESS™ applications
- Fast hose assembly with quick disconnect pressure matched hydraulic couplers
- Manual control valve allows user to "Jog & Hold"
- Ample hydraulic capacity with 8 quart reservoir
- 77.75 lbs. dry weight

P/N 9701-11234 GP10

TEST GAUGES

FORCEGAUGE12-15 is designed for use with PATRIOT® PAT46 and PAT750, Y750 and Y35 family of tools. Not recommended for use with remote head designs.



P/N 9703-58665 FORCEGAUGE12-15 (shown)
 P/N 9702-16405 PT11018 In-Line Pressure Gauge Designed for 10,000 PSI Hydraulic Pumps and Remote Heads

ALFLUID™ HYDRAULIC FLUID



- All weather hydraulic fluid for use with GP10 and Y10AC9 pumps

P/N 9702-16406 ALFLUIDQT
 P/N 9702-16407 ALFLUIDGAL

Please call
 1-877-GO ALTEC
 (1-877-462-5832)
 for more information regarding
 all accessories available

Y10AC9 ELECTRIC POWERED

10,000 PSI Hydraulic Pump



- 1.61 quart reservoir volume
- 6.5"x8.25" base, height of 14.38"
- Lightweight, small size
- 10,000 RPM; 11 amp current draw
- Audible "pop-off" valve indicates proper pressure has been achieved
- Life cycle tested to 100,000 cycles
- Convenient 115 V AC electric powered motor
- Time saving quick disconnect hydraulic fitting
- Hand-held, sealed electric pendant switch with 10 ft. cord

P/N 9702-16403 Y10AC9
 P/N 9702-16408 YACCASE
 10,000 PSI Pump
 Carry Case

10,000 PSI HOSES

Non-conductive hoses with stackable couplers

P/N 9701-24704	PT29900-10	10' x 3/16" diameter
P/N 9702-16409	PT29900-15	15' x 3/16" diameter
P/N 9702-16410	PT29900-25	25' x 3/16" diameter
P/N 9702-16411	PT29901-10	10' x 1/4" diameter
P/N 9702-16412	PT29901-15	15' x 1/4" diameter
P/N 9702-16413	PT29901-25	25' x 1/4" diameter
P/N 9702-16415	PT94	Male Replacement Coupler
P/N 9702-16416	PT93	Female Replacement Coupler



P/N 9702-16416



P/N 9702-16415



AIRCRAFT DYNAMICS™

ROBOT TOOLS

PENTA "T" WRENCH

P/N 9701-98226 2779



ROBOT TOOL
LIFETIME
WARRANTY

- Overall Length: 7.25"
- Penta Opening: 13/16"
- Inside Length: 1/2"
- Weight: 14 oz.

Penta Socket with black oxide finish and proprietary impact steel is securely attached to powder coated "T" handle for extra leverage. Easily remove and tighten Penta Bolts.

TIRED OF BREAKING ADAPTERS?

BLUE BULLY 7/16" TO 1/2" SQ. ADAPTER

P/N 9701-98707 2801

- 7/16" Hex Adapter for 1/2" Sq. Drive Sockets
- Advanced Toughness and Wear Resistance
- Reduced Deformation
- Maximum Mechanical Properties
- Advanced Impact Resistant Technology
- Aerospace Quality/Engineered Shock Steel
- Increased Torque Yield Points

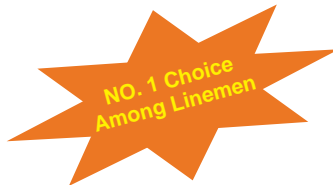

7/16" TRI-BALL QUICK CHANGE CHUCK

P/N 9701-98708 2403

Super Heavy Duty 7/16" (1/2" Sq. Dr.) Quick-Change Chuck. The most secure and durable quick-change chuck available! Utilizing a proprietary three ball bearing system, this chuck will secure your bits, adapters and sockets under extreme circumstances. Designed to be used with high torque 1/2" sq. dr. impact wrenches.



ARE YOUR SOCKETS IMPACT QUALITY SAFE?

*Black Oxide Finish - Heavy-Duty Impact Quality Steel
Best Sockets Available!*

1/2" SQUARE DRIVE PENTA SOCKET

P/N 9701-57240 2775



- Inside Length: 1/2"
- Opening: 13/16"
- Overall Length: 2"

1/2" DOUBLE SQUARE DRIVE DEEP WELL - DOUBLE DUTY SOCKET

P/N 9701-98706 2757 1" and 1-1/8" Openings

P/N 9701-98705 2751 13/16" and 15/16" Openings



- The only penta socket that uses impact quality steel
- 2 sockets in 1
- Length: 5"

SMARTER

- SAFER

- STRONGER

POWER TOOLS
HYDRAULIC TOOLS & ACCESSORIES

USA: 1-877-GO ALTEC
(1-877-462-5832)

www.alteconnect.com



TiiGER

Utility & Pole Pulling Equipment
Created by Linemen for Linemen

The **TiiGER** Cage Organizer...the Safest and most
Efficient Option for Storing your Pole Puller.

DELUXE & STANDARD CAGE ORGANIZER

The Deluxe Cage Organizer

accommodates all the pole puller components, including the pole puller pad and is designed with 3 plus inches of clearance under the cage.

The Standard Cage Organizer

accommodates all the components excluding the pole puller pad and is equipped with wheels and handle.



- Full width hinge preventing any misalignment of the cover
- Handles positioned on the top and on each side
- Constructed with 1/8 inch steel plate for durability
- Equipped with brackets and hold-down straps to secure each component and prevent damage while transporting
- Perfect organizer for pole puller components

SPECS	STANDARD	DELUXE*
Height	28 1/2"	18 1/2"
Width	9 1/4"	32 1/4"
Depth	14 1/4"	24 1/2"
Weight	105 lbs.	86 lbs.

9702-94923 Standard Cage HA0061W
9702-34213 Deluxe Cage HA0060

*Clearance under Cage is 3 1/4 Inches

STEEL GROUND ROD DRIVER

For safer installation of ground rods. The easy to use TiiGER Ground Rod Driver eliminates the need to climb above the rod for installation. It's designed with a unique positioning guide pin, which allows the driver socket of the impact tool to be engaged to the ground rod driver. You can position it at any height for easy installation.



Positioned on ground rod



Attached with socket, fits most tools

ALTEC	TIIGER	DIAMETER SIZES
9703-54354	GRDOO10	1/2" Diameter
9703-54345	GRDOO15	5/8" Diameter
9703-54356	GRDOO20	3/4" Diameter
Custom sizes available		PATENT PENDING

- Heat treated and plated for a long service life
- Designed with a positioning guide pin
- Manufactured from high quality steel, designed with a backside support ridge

POWER TOOLS
HYDRAULIC TOOLS & ACCESSORIES

USA: 1-877-GO ALTEC
(1-877-462-5832)

www.alteconnect.com





TiiGER

Utility & Pole Pulling Equipment
Created by Linemen for Linemen

TiiGER Inc. manufactures the most efficient Pole Pulling equipment, Transformer and Pole Dolly's in the market today...simple to operate, extremely easy to maneuver and lightweight.

HYDRAULIC POLE PULLER



Pole Puller Pad.
Engineered to take the full force of the pole pulling, ultra crack resistant.

At only 57 pounds TiiGER's pole puller is the lightest and safest on the market.

SPECIFICATIONS

MODEL 4001D

Hydraulic Cylinder	57 Pounds
Base Plate	25 pounds
Back Plate	7 pounds
Swivel Chain Hook Assembly	36 pounds
Chain - 6 Feet - 1/2 Alloy	15 Pounds
Operating Pressure	2,800 psi max
Lift at Maximum Pressure	50,120 pounds

P/N 9700-74792 4001D
Pole Puller

P/N 9701-84541
Pole Puller Pad

- The base plate is designed to provide for the lowest possible center of gravity
- Swivel and hook assembly allow for pre-tensioning of the chain and a reduction of stress on the chain
- Back plate prevents chain roll-up resulting in the maximum lift per stroke.
- Model 4001D includes: a 57lb. cylinder, a 25 lb. base plate, a 36 lb. swivel chain hook assembly, chain and back plate.

CUBE HYDRAULIC PORTABLE PUMP



P/N 9702-94936 HB0006
CUBE Pump

The CUBE Pump provides the ability to operate our lightweight pole puller in remote locations without the need for a truck.

- Equipped with a commercial grade gasoline engine for years of trouble free service

SPECIFICATIONS

Size	20" x 20" x 17"
Weight	92 Pounds Dry
Pressure	2,800 psi
Flow	1.8 to 2.0 gpm
Speed (Ext./Ret.)	30 to 40 Seconds

- All terrain pneumatic tires for easy portability
- 1 1/2 gallon hydraulic fluid reservoir
- 4 way / 3 position valve with relief

POWER TOOLS
HYDRAULIC TOOLS & ACCESSORIES

USA: 1-877-GO ALTEC
(1-877-462-5832)

www.alteconnect.com

ID07 IMPACT WRENCH / DRILL

- Ideal for nut and bolt driving, anchor bolt setting, and wood drilling
- Rugged twin hammer impact mechanism with 7/16" quick change chuck
- Dual Spool for open center or closed center hydraulic systems
- Detent forward/reverse spool with wiper seals
- Reverse flow check valve to prevent incorrect connection
- Large trigger for gloved operation
- Up to 500 ft. lbs. torque
- 750 - 2,000 psi
- Flow range of 4-12 gpm
- 7.2 lbs.

P/N 8126-04810 ID07810 Impact/Drill
P/N 9000-07815 ID07815 Impact/Drill with trigger guard



DL07550 REVERSIBLE IMPACT DRILL



- 1/2" keyed chuck capacity for drilling in metal and fiberglass
- Hydraulic flow: 3 - 10 gpm
- 350 - 1250 rpm
- Dual Spool for open center or closed center hydraulic systems
- Forward/Reverse, variable speed
- 9" long; 4" wide
- 1,000 - 2,000 psi

P/N 9000-20025 DL07550

2-in-1 Lineman's Socket

P/N 360-20035 33155 13/16" & 15/16"
P/N 360-20034 33156 1" and 1 1/8"

HAMMER DRILL

- The HD01 Hammer Drill is a rotary, percussion tool for drilling in rock, concrete, or masonry using 1/4 to 1 inch SDS Plus type bits. The HD01 can also be used for drilling in wood or steel by turning percussion off and installing an optional chuck adapter.
- 4200 bpm and 800 rpm for high performance in a small package
- Percussion ON/OFF control
- Assist handle
- Depth gauge
- Flow control to prevent overspeed

P/N 9704-26754 HD01531



TA54603 & TA54103 POLE TAMPERS



- Ideal for soil compaction around utility poles, signs, and fence posts
- Each pole tamer comes standard with a kidney-shaped foot
- Accessories include round and rectangular shoes
- 3 models to choose from



P/N 360-30001 Shown Above Left
P/N 360-30013 Shown Above Right

P/N 9700-17137 TA54603A - Pole tamer including hose with valve (Shown Left)
P/N 360-30013 TA54603 - Tamp assembly without valve
P/N 360-30001 TA54103 - Pole tamer with valve on handle
P/N 360-30010 00833 Kidney-shaped Shoe, 3" x 8" Diameter
P/N 9000-30013 00840 Round Shoe, 6" Diameter
P/N 9700-37869 01070 Rectangular Shoe, 4" x 8" Diameter



HYDRAULIC CRIMPING TOOLS

The "CT" Crimpers are the original low pressure crimping tools that offer many advantages over other means of crimping compression connectors and terminals

- Operate from truck system pressure - no high pressure intensifier required
- An accurate built-in pressure relief ensures that a full die load is achieved at the minimum 1650 psi and prevents over-crimping if higher pressure is present
- Continuous 360° head rotation for easy crimp alignment
- Double Acting - pressure to crimp and pressure to retract which eliminates die "hang up" on the conductor
- Patented open center/closed center selector permits use on either type of hydraulic system
- Works in all temperatures. Dependable in cold weather and will not slow down in the heat
- Reverse - flow check valve to prevent operation if tool is plumbed backwards

CT04016N 4.4 TON CRIMPER

- For Service Entrance Connectors up to 4/0
- Capacity: #6 to 4/0 Copper and Aluminum Conductor
- Compatible with Kearney "D" & "O" dies - accepts "W" dies
- 12 lbs.
- Pressure: 1,650 - 2,500 psi
- Flow range of 3 - 9 gpm
- 3/8" male pipe adapter to -8 SAE port

P/N 8095-00549 CT04016N

CT06026N 6 TON DIELESS

- 6 Ton Dieless For Connectors Up To 750 MCM AL
- Capacity: #10 -750 MCM AL & CU
- Flip top quad point dieless head
- 13 lbs.
- Pressure: 1,650 - 2,500 psi
- Flow range of 3 - 9 gpm
- 3/8" male pipe adapter to -8 SAE port

P/N 9000-00448 CT06026N

CT10 12 TON CRIMPER

- P/N 9000-01016 - "U" type dies, 1" opening
- P/N 9000-00447 - "U" type dies, 1.5" opening
- P/N 9702-16377 - Kearney style WH3
- Pressure: 1,650-2,500 psi
- Flow range of 3 - 9 gpm
- 17 lbs.
- 3/8" male pipe adapter to -8 SAE port

P/N 9000-01016 CT10016N

P/N 9000-00447 CT10066AN

P/N 9702-16377 CT10056DH

CT15 15 TON CRIMPER

- P/N 9701-37780 - Burndy style Y-46 head
- Crimps up to 500 MCM Copper, 1500 MCM Aluminum, 795 MCM ACSR
- Pressure: 1,650 - 2,500 psi
- Flow range of 3 - 9 gpm
- 3/8" male pipe adapter to -8 SAE port

P/N 9701-37780 CT15036GN

CT04016N 4.4 TON CRIMPER



CT06026N 6 TON DIELESS



CT10 12 TON CRIMPER



CT15 15 TON CRIMPER



GD50 GROUND ROD DRIVER

- Drive anvil is designed to fit ground rods to help minimize damage to rod ends
- Anvils are interchangeable to adjust capacity
- Cast lifting eye allows operator to suspend the driver above the rod to be driven
- Long side handle provides increased control
- In-line valve provides on/off control
- For both open and closed center systems
- Capacity: 1/2" - 5/8" rod or 3/4" - 1" rod
- Input flow range of 5 - 9 gpm
- 1,500 - 2,000 psi
- Weighs: 52 lbs.

P/N 9000-99427 GD50132RF 1/2" - 5/8" rod
P/N 9000-99428 GD50133RF 3/4" - 1" rod



HYDRAULIC HANDHELD BREAKERS

MORE POWER

Hydraulic breakers feature a concrete removal rate that's *20% greater per minute than the same class conventional pneumatic breakers.

LOW VIBRATION ZONE

Zone A ISO 5349 Rating allows a user to run 4-8 consecutive hours. A comparable pneumatic which is rated Zone C can only run between .5 hr - 2 hours.

PATENTED EZ RIDE FOOT

Offers precision control when starting to break.

PROPRIETARY DOUBLE SEAL

Increases efficiency and reduces downtime by preventing job site contamination.

LESS NOISE

*4X quieter than the pneumatic alternative.

WATER-RESISTANT

Can be used in wet or underwater conditions – unlike electric breakers.

BIT LOCK SYSTEM

Helps keep parts from loosening or coming apart during operation.

NEW LEG GUARD

Design provides greater control and comfort.

COLD WEATHER OPERATION

Hydraulics will not freeze up in cold conditions – unlike pneumatic alternatives.

NO EXHAUST

Hydraulic Breakers are exhaust free – unlike pneumatic breakers.

* Data provided from a 3rd party research firm.

CONQUER THE ROAD



40/50 LB

2-6" CONCRETE

40/50 LB CLASS BREAKERS

Designed for 2-6" Concrete operations.

ALTEC	Model Number	Shank Size	Hex Length	Handle Configuration	Foot	GPM
8126-45130	BR45130E	1-1/4"	6"	T HANDLE	EZ RIDE	8 GPM
9703-61941	BR45120E	1-1/8"	6"	T HANDLE	EZ RIDE	8 GPM
8126-45150	BR45150	1"	4-1/4"	T HANDLE	STANDARD	8 GPM
8126-45550	BR45550	1"	4-1/4"	T HANDLE	STANDARD	5 GPM
9706-49992	BR45110	7/8"	3-1/4"	T HANDLE	STANDARD	8 GPM

70 LB

6-8" CONCRETE

70 LB CLASS BREAKERS

Designed for 6-8" Concrete operations.

ALTEC	Model Number	Shank Size	Hex Length	Handle Configuration	Foot	GPM
0360-60001	BR67120	1-1/8"	6"	T HANDLE	STANDARD	8 GPM
8126-67130	BR67130	1-1/4"	6"	T HANDLE	STANDARD	8 GPM



THE
SM20

SM20 & SM21 SUBMERSIBLE PUMPS

- Pumps up to 250 gpm at a 10' head
- 2.5" NPTF discharge
- Moves solids up to 5/16"
- Affordable alternative to large, heavy gas or electric pumps
- Can run dry without damage
- Flow range of 4-9 GPM
- 3/8" flush face quick disconnect couplers
- Also features a cast aluminum inlet, a urethane impeller, a Hyrevz™ motor, and is furnished with flush face quick disconnect couplers

P/N 8126-20531 SM2053101



THE
SM21

- Ideal for confined areas and small openings
- Pumps up to 300 gpm at a 10' head
- 2.5" discharge
- Cast iron impeller is within 3/4" of the base, allowing the pump to remove more liquids than other pumps
- Flow range of 4-9 GPM
- 3/8" flush face quick disconnect couplers
- Also features a lifting eye and is furnished with hose whips and flush face quick disconnect couplers

P/N 8126-21511 SM2151101

SM20 & SM21 PUMP ACCESSORIES

P/N 7050-00344 02183 Fire hose lug, 25'

P/N 7050-00345 05133 2 1/2" thread adapter for sump pump to fire hose

P/N 8938-52310 05135 Spanner wrench for pin lug coupler



THE
SM50

SM50 SUBMERSIBLE PUMPS

- Pumps up to 500 gpm
- 3" male camlock discharge
- Completely submersible
- Can draw water down to a depth of 3.5"
- Can run dry without damage
- Flow range of 7-12 GPM

P/N 9700-45814 SM50100

USA: 1-877-GO ALTEC
(1-877-462-5832)

www.alteconnect.com

STANDARD CHAIN SAWS

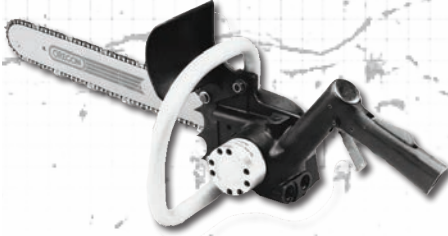

- Designed for all types of pruning and clearing applications
- Interlocking trigger, hand guard, and low kickback bars and chains
- Automatic chain oiling
- Unconventional high power-to-weight ratio
- Designed for use on HTMA Type I or II circuits
- Dual spool for open center or closed center operation
- CS05 models offer 12" and 15" cut length capacities and a 4-6 gpm flow range; CS06 models offer 12", 15", and 20" cut length capacities and a 7-9 gpm flow range

Altec P/N	Cutting Capacity		Replacement Bars	Replacement Chains
P/N 9700-79758	CS05610	12"	P/N 8126-08347	P/N 8126-08348
P/N 360-00020	CS05620	15"	P/N 8126-07683	P/N 8126-07641
P/N 8126-06610	CS06610	12"	P/N 8126-08347	P/N 8126-08348
P/N 360-00018	CS06620	15"	P/N 8126-07683	P/N 8126-07641
P/N 360-00019	CS06630	20"	P/N 8126-04643	P/N 8126-07642

LONG REACH POLE SAW



- Model's available in 75" and 90" O.A.L.
- Ideal for use by right-of-way crews, utilities, parks departments, and grounds keepers
- Feature light fiberglass poles for convenient handling in tight spots
- P/N 9700-84092 and P/N 9700-84093 are designed for HTMA Type II circuits and have an optimum flow of 8 GPM
- P/N 8938-91150 and P/N 9700-84094 are ideal for bucket truck use where hydraulic circuit flow is often limited to 5 GPM

P/N	CS	Cut	GPM	Handle Length	Overall Length
P/N 9700-84092	CS28811	13"	8	60"	90"
P/N 9700-84093	CS28812	13"	8	44"	75"
P/N 8938-91150	CS25811	13"	5	60"	90"
P/N 9700-84094	CS25812	13"	5	44"	75"

79" LONG REACH CIRCULAR SAW

- Hydraulic blade brake minimizes coast down time
- Lightweight fiberglass poles for convenient handling in tight spots
- Angled head design for more visibility and reduced operator fatigue
- Double cone-lock blade nut
- Unique one-piece angled motor and yoke for durability
- 1,000 - 2,000 psi; 5-7 gpm flow range
- Connection: 3/8" NPT male adapter
- 9" blade diameter

P/N 360-00007 CR27891
P/N 9000-34356 34356 Replacement blade

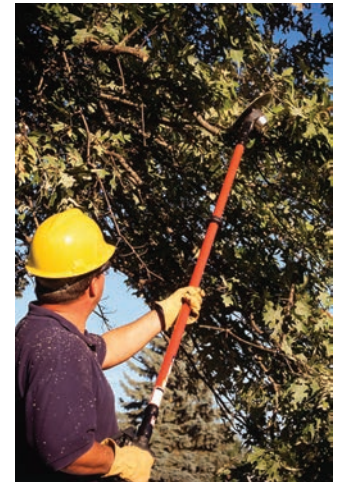

84" POLE PRUNER

- Lightweight head design provides ease of handling for increased operator comfort
- Improved geometry of knife and hook provides increased cutting efficiency
- 2.25" cutting capacity
- Flow range of 3-9 gpm; 1,000 - 2,000 psi
- Built-in hand guard prevents accidental tool activation
- Full power on both opening and closing cycles of cutting blade makes this tool fast and safe to operate
- Strong outer tube construction provides increased durability and extended tool life
- External knife adjustment provides easy routing maintenance

P/N 0360-00014 PR41131 Open Center
P/N 9000-41231 PR41231 Closed Center

12" Long Aluminum Impact Sockets with Steel Inserts for Transmission



- Lightweight, roughly 2 1/2 pounds
- Rated at 750 foot pounds
- For transmission

- Available in 1/2" and 3/4" drive
- Available in hex (6 point) and double square (8 point)
- Custom manufactured sockets - please specify size needed

Please call 1-877-GO ALTEC (1-877-462-5832) for more information on Wright Tool custom-manufactured transmission sockets

8 Point (Double Square) Deep Impact Sockets

P/N 9701-86586	4772	3/8"
P/N 9701-86587	4774	7/16"
P/N 9701-86588	4776	1/2"
P/N 9701-86589	4778	9/16"
P/N 9701-86590	4780	5/8"
P/N 9701-86591	4782	11/16"
P/N 9701-86592	4784	3/4"
P/N 9701-86594	4786	13/16"
P/N 9701-86596	4788	7/8"
P/N 9701-86598	4790	15/16"
P/N 9701-86599	4792	1"
P/N 9701-86600	4794	1 1/16"
P/N 9701-86601	4796	1 1/8"



WRIGHT TOOL

PERFECTING PERFORMANCE

1/2" Drive 5 Point Penta Socket



- Penta socket to open transformers
- P/N 9701-86453 9076

Tool Adapter

- 7/16" x 1/2" adapter for the linesman working overhead with their hydraulic guns

P/N 9701-86452 4422



IMPACT WRENCH & DRILL ACCESSORIES

Crescent 1/2" Drive, 6 Pt. Deep Impact Socket Set

- 1/2" Drive 6PT. Deep Impact Socket, 78 MML, CRV
- Includes 7/16", 1/2", 9/16", 5/8", 11/16", 3/4", 13/16", 7/8"

P/N 9706-40837 192-CIMS2



Heavy Duty Sockets (Standard/Deep)

	P/N 9817-52738	9/16"	(Standard)
	P/N 9817-53398	5/8"	(Standard)
	P/N 9817-52741	7/8"	(Standard)
	P/N 9817-53398	11/16"	(Standard)
	P/N 9817-52740	3/4"	(Standard)
	P/N 9910-05376	13/16"	(Standard)
	P/N 9817-53232	15/16"	(Standard)
	P/N 9817-52744	1"	(Standard)
	P/N 9700-10785	1 1/16"	(Standard)
	P/N 9817-53399	1 1/8"	(Standard)
	P/N 9817-53401	11/16"	(Deep)
	P/N 9817-53230	3/4"	(Deep)
	P/N 9817-53400	13/16"	(Deep)
	P/N 9817-53233	1"	(Deep)
P/N 9817-52734	1 1/16"	(Deep)	
P/N 9910-05372	1 1/8"	(Deep)	

5/8" Hex Impact Type

GearWrench Heavy Duty Deep Impact Sockets (1/2" Drive, 6 pt)



1/2" Drive, Hex Type

P/N 9706-37558	3/8"	84546
P/N 9706-37559	7/16"	84547
P/N 9706-37560	1/2"	84548
P/N 9706-37561	9/16"	84549
P/N 9706-37562	5/8"	84550
P/N 9706-37563	11/16"	84551
P/N 9706-37564	3/4"	84552
P/N 9706-37565	13/16"	84553
P/N 9706-37566	7/8"	84554
P/N 9706-37567	15/16"	84555
P/N 9706-37568	1"	84556
P/N 9706-37569	1 1/16"	84557
P/N 9706-37570	1 1/8"	84558

Nut Runner



- P/N 9000-99489 is a 7/16" x 1/2" square drive adapter designed for use with impact wrenches
- P/N 9000-96179 NR1 nut runner is for 5/8" x 3/4" hardware and does not include an adapter

P/N 9000-96179 DDLS-4 5/8" x 3/4" without Adapter
P/N 9000-99489 49314 Adapter for P/N 9000-96179



Chuck Adapter for Impact Tool

- Adapts a 1/2" square drive impact to drill bits up to 1/2" shank

P/N 9700-13302

POWER TOOLS
HYDRAULIC TOOLS & ACCESSORIES

USA: 1-877-GO ALTEC
(1-877-462-5832)

www.alteconnect.com

IMPACT WRENCH & DRILL ACCESSORIES

Wood Owl Deep Cut Ship Augers (Quick-Change Impact Drill Bits)



- Spurred cutting edge for fast and even cutting
- Course, burr-free lead screw of Teflon® coated carbon steel construction for quick, on-target starts without material build-up
- Unique twist design for clean chip removal, even in the deepest cuts
- Perfectly cocentric for accurate diameter of holes

P/N 9702-72444	08806	18" Long	9/16" Diameter
P/N 9702-46427	08808	18" Long	11/16" Diameter
P/N 9702-21868	08810	18" Long	13/16" Diameter
P/N 9702-31115	08812	18" Long	15/16" Diameter
P/N 9701-36911	08813	18" Long	1" Diameter
P/N 9701-36912	08814	18" Long	1 1/16" Diameter
P/N 9701-36913	08815	18" Long	1 1/8" Diameter
P/N 9701-36914	08817	18" Long	1 1/4" Diameter
P/N 9701-36915	08818	18" Long	1 3/8" Diameter
P/N 9701-36916	08819	18" Long	1 1/2" Diameter
P/N 9701-36918	01004	24" Long	7/16" Diameter
P/N 9701-36919	01006	24" Long	9/16" Diameter
P/N 9701-36920	01008	24" Long	11/16" Diameter
P/N 9701-36921	01010	24" Long	13/16" Diameter
P/N 9701-36922	01012	24" Long	15/16" Diameter
P/N 9701-36923	01013	24" Long	1" Diameter
P/N 9701-80636	01014	24" Long	1 1/16" Diameter
P/N 9701-36925	01015	24" Long	1 1/8" Diameter
P/N 9701-36927	01017	24" Long	1 1/4" Diameter
P/N 9701-36928	01018	24" Long	1 3/8" Diameter
P/N 9701-36929	01019	24" Long	1 1/2" Diameter

HIGH PRESSURE HYDRAULIC TOOLS & ACCESSORIES

High Pressure Screw Together Couplings



- 10,000 psi working pressure
- Double shut-off hydraulic coupling
- Interchangeable half-for-half with all manufacturers and ball check designs
- Captive poppet seal, durable and leak-free
- Couplings can be connected under pressure up to 1,000 psi

P/N 9701-06006 3/8" Female
 P/N 9701-06007 3/8" Male
 P/N 9701-06009 1/4" Female
 P/N 9701-06008 1/4" Male

High Pressure 10,000 PSI Hose Assembly



- 3/8 I.D. hose
- 10,000 psi working pressure
- 3/8" male pipe ends
- Strain relievers on both ends
- Male quick coupler on one end with a cap

P/N 9700-64760 50', 1/4 MPT

HYDRAULIC TOOLS & ACCESSORIES

ALTEC SUPPLY Pole Puller



- Hydraulically actuated, supplying the necessary power to remove the most stubborn, deeply embedded poles
- Weighs 121 lbs.
- Features a large handle for optimum mobility and convenience
- Features 7' of electro-zinc plated chain
- Exerts 47,000 lbs. of force at 2,400 psi
- (2) Adapter Fittings and (1) Quick Disconnect Set needed (see below for further information)

P/N 720-90001 Pole Puller (top left photo)
 P/N 720-00001 Base Plate Only
 P/N 234-30015 Chain Only
 P/N 9000-20001 Pole Puller Pad (above right photo)
 P/N 274-01852 Adapter Fittings (Need Qty 2)
 P/N 9701-31975 Quick Disconnect Set (Need Qty 1)



HYDRAULIC TOOLS & ACCESSORIES

1/2" NPT Quick Disconnect Set



- Meets NFPA standard T3.20.15
- Twin-Guard sealing system prevents seepage and allows connection and disconnection against pressure up to 500 psi
- Dual flush face valving for minimal fluid loss and air inclusion
- Tubular valve and sleeve construction for high fluid flow with low pressure drop
- Push-to-connect latching for one hand operation
- Standard seal material - Teflon channel seal and Buna-N O-Ring back-up
- Standard body material - Zinc plated steel
- Operating Pressure: 3,000 - 9,000 psi

P/N 356-20088 Parker Hannifan FF-370-8FP

3/8" NPT Quick Release Coupling



- Spillage .008cc
- Interchangeable
- Special profile eurothane seal
- Features a 3/8" body size with 3/8" female pipe thread at each end
- Coupler allows perfect connect under highest pressure without any seal extrusion; design eliminates dirt inclusion
- Eliminates leakage at lowest pressure (dripless)
- Perfect connect under highest pressure without seal extrusion
- P/N 9000-20133 features O-ring Boss Connections
- 10GPM unit withstands pressure up to 3625 psi
- HTMA Hydraulic Tools Association Standard
- Complete unit (male/female)

P/N 356-20132 Quick Release Coupling Set, Complete

Cooper Tools APEX QR-514 Quick Releasing Chuck 7/16" x 2 1/8"



- Material tool steel type quick change adapter
- Drive size 1/2"(female square)
- Opening size 7/16" (hex)
- Overall length 2 1/8"
- Locking type pin

P/N 9701-71688 QR-514

Dust Cap & Plugs



- Protects your couplers and adapters from dust and debris
- The dust cap fits the female end, and the dust plug fits the male end

P/N 9000-20144 Dust Cap

P/N 9000-20145 Dust Plug

Adapters



- Hose assemblies can be applied directly to the tool without the use of body assemblies or nose pieces
- O-ring Boss; steel; zinc plated

P/N 274-01851 .38 NPT x -6 SAE Male Straight Thread Adapter

P/N 274-01852 .38 NPT x -8 SAE Male Adapter

3/8" FF Series Flat Faced Couplings



- An RoHS compliant, flat-face, dry break, minimum spill hydraulic coupling with a 5075 psi
- Automatic connection with a sleeve lock
- Flat face couplings allow easy cleaning of the contact faces

before connection, minimize any entry of air on connection, and prevent any loss of fluid on disconnection

P/N 9701-31975

Low Pressure HTMA Couplers



- This female HTMA coupler is 3/8" NPTF internal thread
- Maximum operating pressure is 3,000 psi

P/N 9000-41777 Greenlee F020195K



- This male HTMA coupler is 3/8" NPTF internal thread
- Maximum operating pressure is 3,000 psi

P/N 9000-41780 Greenlee F020198K

Adapters



- Hose assemblies can be applied directly to the tool without the use of body assemblies or nose pieces
- O-ring Boss; steel; zinc plated

P/N 274-01154 9/16" UN/UNF x 3/8" Female NPSM Swivel

P/N 274-01155 9/16" UN/UNF x 1/2" Female NPSM Swivel

POWER TOOLS
HYDRAULIC TOOLS & ACCESSORIES

USA: 1-877-GO ALTEC
(1-877-462-5832)

www.alteconnect.com

HYDRAULIC TOOLS & ACCESSORIES

POWER TOOLS
HYDRAULIC TOOLS & ACCESSORIES

USA: 1-877-GO ALTEC
(1-877-462-5832)

www.alteconnect.com

Non-Conductive Tool Hose with Swivels and Quick Disconnects



- Twin line, certified 3/8" non-conductive tool hose assembly
- -8 SAE male to 0.38 NPT swivel fittings and quick disconnects attached

Red:
P/N 9000-12247 8' Length
P/N 9000-12248 10' Length

Orange:
P/N 9701-70619 8' Length
P/N 9701-70620 10' Length

Please contact your Altec Parts representative at 1-877-GO ALTEC (1-877-462-5832) for special order lengths.

Low Pressure Non-Conductive Tool Hose Assemblies



- Twin line, certified 3/8" non-conductive tool hose assembly
- Special order lengths are also available

Red:
P/N 271-29444 8' Length
P/N 271-29457 10' Length
P/N 271-29542 25' Length

Orange:
P/N 9000-50385 8' Length
P/N 9000-50386 10' Length

Please contact your Altec Parts representative at 1-877-GO ALTEC (1-877-462-5832) for special order lengths.

Non-Conductive Tool Hose with Quick Disconnects



- Twin line, certified 3/8" non-conductive tool hose assembly
- HTMA quick disconnects attached each end

Red:
P/N 9702-90038 8' Length
P/N 9702-08915 10' Length

Please contact your Altec Parts representative at 1-877-GO ALTEC (1-877-462-5832) for special order lengths.

Fast-Stor® Dura-flex™ Insulated Low Pressure Hydraulic Tool Hose



- Flexible and easy to handle
- Meets SAE J517 for less than 50 micro-amps leakage at 75,000 volts per foot
- UV and ozone-resistant jacket prevents cracking and moisture ingress leading to increased conductivity

- High abrasion-resistant jacket extends service life
- Self-retracting coil design eases handling and storage
- Twin-line bonded construction eliminates tie straps for safer handling
- Smooth non-porous jacket repels contamination and debris
- Quick Disconnects and other fittings sold separately
- Assembly features 3/8" NPT male fittings

P/N 9702-23516 6' Hose
P/N 9702-23517 8' Hose
P/N 9702-23518 10' Hose

Crimping Dies and Die Storage

Installation Dies

Burndy #	Altec Part #
W-BG	9700-26993
W-O	0683-00116
W-C	9000-10167
W-161	9000-01614
W-162	9000-10170
W-163	9000-01616
W-166	9000-10173
W-243	9000-10174
W-247	9000-10175
W-249	9000-10176
W-164	9000-10177
W-237	9000-10179
W-239	9000-10180
WK-840	9700-06365

Die Storage

P/N 9000-04946	PT4946 (W or X Die Case)
P/N 9000-29291	PT29291 (U Die Case)

Die Kits

P/N 9702-16399	UDIEKITAL
P/N 9702-16400	UDIEKITCU
P/N 9702-16401	UDIEKITHYGRD



ACSR cutting dies

Burndy #	Altec Part #	P/N 9000-29291	"U" Die Case -
W-28K	9700-15446	P/N 9000-04946	"U" Die Case - 6 die sets

There are too many dies to list them all, this is just a representative list of some of the most common dies. "W" and "X" style dies are used in the MD6 & MD7 series of tools and also the OUR840. "U" dies can be used with the 35, 39 and 750 series of tools (both battery versions and standard hydraulic versions). The 46 series of tools use "P" dies and when using the PUADP1 adaptor they can also use the "U" style of dies. For more complete information, please contact Altec at 1-877-GO ALTEC (1-877-462-5832).

P/N 9000-96183
Holds 12 die sets

HYDRAULIC TOOL REPLACEMENT PARTS

Greenlee Impact Wrench Replacement Parts



P/N 9000-99877 Seal kit
P/N 9000-99943 Anvil
P/N 9000-48313 Link for trigger

Impact Wrench Replacement Parts



P/N 8855-32328 Seal kit for model ID04
P/N 9000-60791 Seal kit for model ID07
P/N 360-29003 Seal kit for model IW08
P/N 360-29004 Seal kit for model IW09

Greenlee Crimper Replacement Parts Crimper Replacement Parts



Seal kits:
P/N 9700-14415 (Model LPK1230)
P/N 9000-49358 (Model LPK1550)
P/N 9700-14407 (Model H1216)
P/N 9700-14416 (Model 48735/48730)
P/N 9700-14414 (Model 48750)



P/N 8126-06538 Seal kit for model CT10
P/N 9700-14402 Seal kit for model CT15

Greenlee Tamper Replacement Parts Tamper Replacement Parts



P/N 9000-39009 Seal kit for tamp with valve
P/N 9700-06663 Seal kit for tamp without valve
P/N 9000-99898 Hose clamp
P/N 9000-99807 Ram
P/N 8126-40276 Packing nut



P/N 360-39004 Seal kit for model with valve
P/N 360-39007 Seal kit for model without valve
P/N 360-39001 Ram kit with nose guard and seals
P/N 360-39050 Hose guide

Long Reach Chain Saw Replacement Parts



P/N 360-09010 Seal kit for CS23/26

Greenlee Long Reach Chain Saw Replacement Parts



P/N 9000-48254 Seal kit
P/N 9000-99890 Sprocket

HYDRAULIC TOOL ASSEMBLIES

- REVOLUTIONIZING THE WAY YOU BUY HYDRAULIC TOOLS!

**ORDER FROM ANY OF THE
TOOL ASSEMBLIES
ON THE FOLLOWING PAGES**
Or Call 1-877-GO ALTEC (1-877-462-5832)
To Specify Other Combinations / Lengths

**Assemblies Are Available
With Any Hydraulic Tool**
Call 1-877-GO ALTEC (1-877-462-5832)

Impact Wrench Assembly

P/N 9705-71428

(1) P/N 9703-89710
Burndy HIW716MAG Impact
Wrench

(1) P/N 271-29444
8' Hose (Non-Conductive)

(1) P/N 356-20132
3/8" HTMA Flush
Face Male and
Female Couplers

(2) 274-01154
Swivel Adapters



**POWER TOOLS
HYDRAULIC TOOLS & ACCESSORIES**

USA: 1-877-GO ALTEC
(1-877-462-5832)

www.alteconnect.com

HYDRAULIC TOOL ASSEMBLIES

- REVOLUTIONIZING THE WAY YOU BUY HYDRAULIC TOOLS!

POWER TOOLS
HYDRAULIC TOOLS & ACCESSORIES

USA: 1-877-GO ALTEC
(1-877-462-5832)

www.alteconnect.com

Impact Wrench Assembly

P/N 9000-96198

- (1) P/N 7010-69023 Greenlee Impact Wrench
- (1) P/N 271-29444 8' Hose (Non-Conductive)
- (1) P/N 356-20132 3/8" HTMA Flush Face Male, Female Couplers
- (2) 274-01155 Swivel Adapters



Impact Wrench Assembly

P/N 9703-31734

- (1) P/N 9703-29578 Greenlee HW1 Standard Impact Wrench
- (1) P/N 271-29444 8' Hose (Non-Conductive)
- (1) P/N 356-20132 3/8" HTMA Flush Face Male and Female Couplers
- (2) P/N 274-01155 Swivel Adapters



Impact Wrench Assembly

P/N 9703-53862

- (1) P/N 9703-29580 Greenlee HW1V Adjustable Torque Impact Wrench
- (1) P/N 271-29444 8' Hose (Non-Conductive)
- (1) P/N 356-20132 3/8" HTMA Flush Face Male and Female Couplers
- (2) P/N 274-01155 Swivel Adapters



Impact Wrench Assembly

P/N 9703-53767

- (1) P/N 9702-03368 Burndy HIW716ENF ENFORCER™
- (1) P/N 271-29444 8' Hose (Non-Conductive)
- (1) P/N 356-20132 Quick Release Coupling
- (1) P/N 274-01154 9/16" UN/UNF x 3/8" Female NPSM Swivel



Impact Wrench Assembly

P/N 9000-96212

- (1) P/N 9000-07815 Impact Wrench with Trigger Guard
- (1) P/N 271-29444 8' Hose (Non-Conductive)
- (1) P/N 356-20132 3/8" HTMA Flush Face Male and Female Couplers
- (2) P/N 274-01155 Swivel Adapters



Impact Wrench Assembly

P/N 9703-53806

- (1) P/N 8126-04810 Impact Wrench without Trigger Guard
- (1) P/N 271-29444 8' Hose (Non-Conductive)
- (1) P/N 356-20132 3/8" HTMA Flush Face Male and Female Couplers
- (2) P/N 274-01155 Swivel Adapters



Pole Puller Assembly

P/N 9703-08570



P/N 720-90001
(1) Pole Puller



Hose Fittings
(2) 274-01852

Pole Puller Assembly

P/N 9000-04001



P/N 9700-74792 Tiiger Pole Puller



P/N 356-20088 Quick Release Coupling Set, Complete

Ground Rod Driver Assembly

P/N 9000-70646



P/N 9000-11192
Greenlee HRD-58
Ground Rod Driver



P/N 356-20132
(1) 3/8" HTMA Flush Face Male and Female Couplers



P/N 274-01154 9/16" UN/UNF x 3/8" Female NPSM Swivel
P/N 274-01155 9/16" UN/UNF x 1/2" Female NPSM Swivel

ORDER FROM ANY OF THESE TOOL ASSEMBLIES

Or Call 1-877-GO ALTEC (1-877-462-5832) To Specify Other Combinations / Lengths

LPK1240 Assembly

P/N 9000-96214



P/N 9000-49345
(1) Fairmont
LPK 1240

P/N 271-29444
(1) 8' Hose
Non-Conductive



P/N 274-01155
(2) Swivel Adapters

P/N 356-20132
3/8" HTMA Flush
Face Male and
Female Couplers

20" Chain Saw Assembly

P/N 9000-50193



P/N 9000-49603
(1) Greenlee HCS820 20"
Standard Chain Saw



Hose Fittings
(1) 274-01851
(1) 274-01852

P/N 356-20132
(1) Quick Release
Coupling Set

15" Chain Saw Assembly

P/N 9000-96219



P/N 360-00020 CS05620
(1) Stanley Chain Saw



P/N 9000-12247
8' Length Non-
Conductive Hose
with Swivels and
Quick Disconnects

62.5" Pole Saw Assembly

P/N 9000-96197



P/N 7010-69018
(1) 62.5" Pole Saw

P/N 271-29444
(1) 8' Hose
Non-Conductive



P/N 274-01154
(1) Straight Adapter
P/N 274-01155
(1) Swivel Adapter

P/N 356-20132
(1) Quick Release
Coupling

75" Pole Saw Assembly

P/N 9000-96210



P/N 9000-38568
(1) 75" Pole Saw

P/N 271-29444
(1) 8' Hose
Non-Conductive



P/N 274-01154
(1) Straight Adapter
P/N 274-01155
(1) Swivel Adapter

P/N 356-20132
(1) Quick Release
Coupling Set

Pole Tamper Assembly

P/N 360-30013



P/N 360-30013
(1) Stanley Pole Tamper
without valve

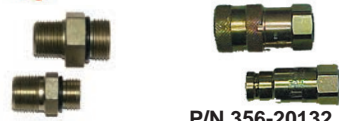

Hose Fittings
(1) 274-01851
(1) 274-01852

P/N 356-20132
(1) 3/8" HTMA Flush
Face Male and
Female Couplers

Pole Tamper Assembly

P/N 9000-96199



P/N 8930-00400
(1) Greenlee
Pole Tamper



Hose Fittings
(1) 274-01851
(1) 274-01852

P/N 356-20132
(1) 3/8" HTMA Flush
Face Male and Female
Couplers

60" Pole Tamper Assembly

P/N 9000-96216



P/N 360-30016
Greenlee H4802-5
(1) 60" Pole Tamper



Hose Fittings
(1) 274-01851
(1) 274-01852

P/N 356-20132
(1) Quick Release
Coupling

Pole Tamper Assembly

P/N 9700-17137



P/N 9700-17137 TA54603A
(1) Stanley Pole Tamper
including hose with valve



Hose Fittings
(1) 274-01851
(1) 274-01852

P/N 356-20132
(1) 3/8" HTMA Flush
Face Male and Female
Couplers

POWER TOOLS
HYDRAULIC TOOLS & ACCESSORIES

USA: 1-877-GO ALTEC
(1-877-462-5832)

www.alteconnect.com

Assemblies Are Available With Any Hydraulic Tool

Call 1-877-GO ALTEC (1-877-462-5832)

Altec
Supply

GAS-POWERED TOOLS & ACCESSORIES

**POWER TOOLS
GAS-POWERED TOOLS**

Stihl MS 170 Chain Saw



- Features STIHL Quickstop® inertia chain brake, Master Control Lever™, anti-vibration system, easy-off filter cover, and translucent oil and gasoline tanks
- Ematic™ Lubrication System
- IntelliCarb™ Compensating Carburetor
- Displacement: 30.1 cc (1.84 cu. in.); engine power: 1.3 kW
- Weight (powerhead only): 3.9 kg (8.6 lbs.)
- Fuel capacity: 250 cc (8.5 oz.); chain oil capacity: 145 cc
- Oilomatic® chain: .325" Rmc3
- Stihl rollomatic® Mini

P/N 9700-77802 MS170 16" Bar
 P/N 9706-37497 3005-3913 Replacement Bar, 16"
 P/N 9706-37498 61-PMM3 Replacement Chain, 16"

Stihl MS 211 Chain Saw



- Built in the USA
 - STIHL Easy2Start™ (E)
 - IntelliCarb™ Compensating Carburetor
 - Quick Chain Adjuster (QCA) (B)
 - Toolless fuel and oil caps with retainers
 - Winter/Summer Shutter
 - Displacement: 35.2 cc
 - Engine power: 1.7 kW (2.3 bhp)
 - Powerhead Weight: 4.6 Kg (8.82 Lbs.)
 - Guide Bar Lengths* (Recommended Ranges): 12" To 16"
 - Fuel Capacity: 310 Cc (10.1 Oz.)
 - Chain Oil Capacity: 180 cc (6.1 oz.)
 - Oilomatic® chain: 3/8" PM3
- P/N 9706-37501 MS211C-BE-16" 16" Bar
 P/N 9703-81918 3005-4813 Replacement Bar, 16"
 P/N 9706-37502 63-PM3-55 Replacement Chain, 16"

Stihl MS 251 Chain Saw



- Ematic™ Bar Lubrication System delivers proper lubrication while reducing oil usage by up to 50%
- The Automatic Bar and Chain Oiler allows the operator to concentrate on cutting rather than bar and chain lubrication
- Electronic Ignition provides dependable and easier starting along with smoother running and performance
- Anti-vibration System helps reduce operator fatigue and improve comfort
- Quickstop® Chain Brake System is designed to stop the chain in fractions of a second and can be activated manually or by inertia if the kickback force is sufficient
- Translucent Fuel Tank and Balanced Fuel and Oil Tank
- Displacement: 45.6 cc; engine power: 2.2 kw
- Fuel capacity: 390 cc; chain oil capacity: 198 cc
- Oilomatic® chain: .325" Rmc3

P/N 9706-05592 MS251 18" Bar
 P/N 9706-37499 3005-4717 Replacement Bar, 18"
 P/N 9706-37500 RM3-62 Replacement Chain, 18"

Stihl BT 45 Lightweight Planting Auger



- Dependable, powerful and lightweight engine
- Anti-vibration system for comfortable use
- Two-speed gearbox, with a neutral position as well as a reverse gear
- Toolless chuck accepts 1/2" drive bits up to 1" in diameter
- Friction clutch is designed to slip if bit stalls
- Balanced design with well-spaced handles
- Front handle is easily adjustable (360° rotation)
- Can be converted to planting auger with kit (4314-007-1001)
- Displacement: 27.2 cc (1.6 cu. in.)
- Engine power: 0.8 kW (2.3 bhp)
- Weight: 4.8 Kg (10.5 Lbs.)
- Fuel Tank Capacity: 250 Cc (8.5 Oz.)
- Drill Speed: 1st Gear: 910 rpm; 2nd Gear: 2,710 rpm; Reverse: 810 rpm

P/N 9000-45000 BT45
 P/N 9706-37503 4314-007-1001 Earth Auger Kit
 P/N 9706-37504 4314-680-1903 3" Planting Hole Drill
 P/N 9706-37505 4314-680-1904 4" Planting Hole Drill
 P/N 9706-37506 4314-680-1905 5" Planting Hole Drill

Wood Boring Bits:

P/N 9706-37507 4314-682-5001 1/2" Dia. Wood Boring Bit
 P/N 9706-37508 4314-682-5002 3/4" Dia. Wood Boring Bit
 P/N 9706-37509 4314-682-5003 7/8" Dia. Wood Boring Bit
 P/N 9706-37510 4314-682-5004 1" Dia. Wood Boring Bit

USA: 1-877-GO ALTEC
(1-877-462-5832)

www.alteconnect.com



GAS-POWERED TOOLS & ACCESSORIES

Tanaka Reversible TED270PFR Gas Drill



- Features a 27 cc, 1.4 h.p. PureFire two-stroke engine
- 20:1 gear reduction
- Powered reversing feature
- Dual position padded front handle
- Heavy-duty fuel tank protector

P/N 9000-88874 TED-270PFR

Tanaka TED270PFL Gas Engine Drill



- Portable, lightweight, and durable; allows users to drill anywhere and in any position
- 26 CC
- 1/2" chuck capacity
- Not reversible

P/N 9817-52769 TED-270PFL

Stihl Pole Pruners

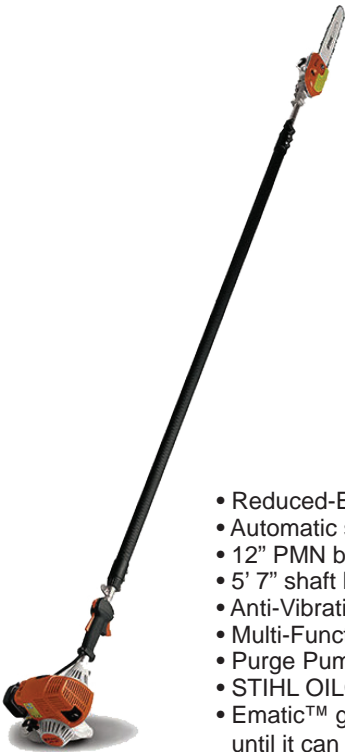

- Ideal for hard-to-reach places
- Adjustable shaft telescopes to 11' 6"
- Features a side mount chain adjuster
- Powered by a proven low-emissions engine
- Automatic side bar and chain oiler
- 12" PMN bar and chain
- 7' 6" - 11' 6" shaft length
- STIHL OILOMATIC® saw chain. STIHL makes its own saw chain
- Ematic™ guide bar includes a polymer ramp reservoir which holds bar oil until it can be picked up by passing chain. This can reduce oil usage by up to 50%
- Side-access chain tensioner for easy chain adjustment
- Sprocket cover cut out for faster chip removal
- Gear-driven oil pump

P/N 9700-67637 HT101
 P/N 9706-37511 3005-3905
 P/N 9706-37512 61MM3-44

Telescoping (Left)
 Replacement Bar, 12"
 Replacement Chain, 12"

- Reduced-Emission Engine Technology
- Automatic side bar and chain oiler
- 12" PMN bar and chain
- 5' 7" shaft length
- Anti-Vibration System
- Multi-Function Control Handle
- Purge Pump Primer
- STIHL OILOMATIC® saw chain. STIHL makes its own saw chain
- Ematic™ guide bar includes a polymer ramp reservoir which holds bar oil until it can be picked up by passing chain. This can reduce oil usage by up to 50%
- Side-access chain tensioner for easy chain adjustment
- Sprocket cover cut out for faster chip removal
- Gear-driven oil pump

P/N 9700-52960 HT100
 P/N 9706-37511 3005-3905
 P/N 9706-37512 61MM3-44

Standard (Right)
 Replacement Bar, 12"
 Replacement Chain, 12"



POWER TOOLS
 GAS-POWERED TOOLS

USA: 1-877-GO ALTEC
 (1-877-462-5832)

www.alteconnect.com

GENERATORS

POWER TOOLS
GAS-POWERED TOOLS

USA: 1-877-GO ALTEC
(1-877-462-5832)

www.alteconnect.com

REDI-LINE 1600 Watt Generator



P/N 683-70176

- Operate from vehicle batteries and convert DC power to AC to run power tools, and electrical equipment where commercial AC power is not conveniently available
- Encased in rugged, steel enclosures, and constructed for long life with minimum maintenance
- Compact and whisper quiet, unlike gasoline engine driven generators, it produces no dangerous fumes or exhaust
- Can be mounted in any position - even up-side-down
- Advanced demand start circuit is sensitive enough to activate the generator even with variable speed power tools

Honda EM3800 SXA Generator

- Runs 10.4 hours at 3300W rated load on 6.6 gallons fuel
- 120/240V selector switch, simultaneous AC/DC use, automatic voltage regulator
- Honda 8HP GX240 242cc engine features a single cylinder, an overhead valve, oil alert, electric start, air-cooled

P/N 0604-10029 Generator
P/N 9700-36681 Remote Start



Honda EM5000 SXX2A Deluxe Generator



- Honda 11HP GX340 337cc engine features a single cylinder, an overhead valve, oil alert, electric start, and is air-cooled
- Runs 8.3 hrs. on 6.6 gallons fuel
- 120/240V selector switch

P/N 683-70090 Generator
P/N 9700-36681 Remote Start

Honda EU3000IS Generator

- 6.5 HP single cylinder engine features 196 cc displacement, electronic ignition, simultaneous AD/DC use, electronic circuit breakers, inverter (computer friendly), an automatic voltage regulator, and air-cooling
- Runs 7.2 hours (2800W rated load) on 3.4 gallons fuel
- P/N 9701-34629 also features the best keyless remote start available in the industry with a range of 400' - with obstructions

P/N 0604-60033 Generator Features Wireless Remote Start



Cummins 7.0 HGJAD-2560 Generator



- Integrated hydraulic pump option (pictured)
- Quiet; low vibration; enclosed muffler
- Electronic governor for voltage stability and frequency control; self-diagnostic capability
- Electric fuel injection for hot and cold start capability

P/N 9701-39024 HGJAD-2560

PORTABLE POWER UNITS

Greenlee F13 Portable Hydraulic Power Unit

With Adjustable 5-8 gpm Hydraulic Oil Flow

- Easy pull recoil start and dependable Honda 4-stroke OHV GX390 gasoline engine
- Low oil alert and shutdown protection system
- The engine is CARB (California Air Resources Board) certified as well as compliant with upcoming 2011 EPA emissions standards
- Constructed with a durable, powder-coated, welded steel tubular frame protects the engine, fan cooled oil cooler and oil reservoir, while providing easy access to all service points
- Oversized fan cooled oil cooler increases run time, tool performance, operator comfort and overall system reliability
- Large 13" diameter by 3" wide no-flat tires ensure easy job site handling and transport over a wide variety of surfaces and soils
- Quick-release telescoping handles
- Hydraulic oil-level site gauge
- Supplied with HTMA flat-faced couplers and a 25-micron return line filter
- Easy access to all operation and service points



P/N 9000-49618 F13 (31378)

SPECIFICATIONS	
Horsepower	13 at 3,600 rpm (9.7 kW at 3,600 rpm)
System	Open-Center
Rated Flow	5 - 8 gpm (19 - 30 lpm)
Rated Pressure	2,000 psi (138 bar)
Sound Power Level	LWA = 101 dB
Fuel	Gasoline 1.7 gal (6.5 l)
Hydraulic Oil Capacity	1.8 gal (7.0 l)
Dry Weight*	168 lb (76 kg)
Length (handles retracted)	28" (710 mm)
Width	23.5" (597 mm)
Height	25.5" (648 mm)

Stanley GT18 Power Unit



- Type I or Type II hydraulic circuit
- Electronically controlled engine
- Features adequate power and speed - provides 5 or 8 GPM
- Auto idle feature - lower fuel
- Features adequate power, consumption, superior cooling, and less noise
- Quartz hour meter on control panel records engine run time
- Tool circuit lockout during engine startup
- Designed for continuous duty operation of any hydraulic tool in the Type I or Type II category or wherever 8 GPM@ 2000 psi of hydraulic power is required
- Lift & Latch handle with fold-up side handles
- 35-AH sealed, non-spillable, no maintenance battery located in covered compartment
- Electric start engine has pressure lubrication system, low engine oil shut down & spin on oil filter; in-tank hydraulic filter with dipstick and easy access filter replacement

P/N 9702-16392 Stanley GT18B02 5 or 8 GPM
Briggs & Stratton 18 HP

Stanley GT13 Power Unit



- Medium duty power unit
- 7 GPM @ 2000 psi
- Features adequate power and cooling
- Power-On-Demand (POD) throttle idles engine when tool is not in use - lower fuel consumption
- Stainless Steel frame with fold-up handle, wheels and lifting eye - simplifies transportation & storage
- Honda GX390 pull start engine with low engine oil protection
- Hydraulic pump mounts directly to engine
- Shaft driven fan provides 2 HP of hydraulic cooling
- Compact and portable - weighs 162 lbs.

P/N 9702-06056 Stanley GT13H02

POWER TOOLS
GAS-POWERED TOOLS

USA: 1-877-GO ALTEC
(1-877-462-5832)

www.alteconnect.com

GAS-POWERED PUMPS

Echo Water Pump

- Performs well in the most adverse conditions
- Features an all die-cast aluminum pump housing and cast iron volute for superior suction/discharge performance
- Engine Displacement: 21.2 cc
- Fuel Capacity: 14 fl. oz.
- Max. Discharge: 1,680 gph
- Max. Suction: 24.5'
- Hose Size (Inlet/Outlet): 1"

P/N 9000-99831 WP-1000



SIEVERT TORCH & ACCESSORIES

Sievert Soft Flame Burner



- Soft flame design ideal for cable work and other heat shrinking applications
- Sweeping, powerful yellow and blue soot-free, windproof flames
- Fresh air sucks in and keeps the burner head cold to minimize the risk of burning the shrink material
- Heats the sleeves efficiently yet soft enough not to overheat the shrink material
- Work pressure 29 psi; burner diameter 1.5"
- Thick walled sleeves max 5.9"

P/N 9700-47733

Sievert Gas Regulator



- High quality brass construction P.O.L. inlet for refillable propane cylinder
- LH 9/16" male outlet
- Preset regulator; 28 psi for 1 lb. disposable cylinder variable hose connection
- Manufactured in brass to ensure the highest quality and long service life
- Valves have a very high capacity and precise outlet pressure
- LTS valve is designed to detect minor leaks
- Regulator with LTS is always combined with a hose failure valve

P/N 9700-47736

Sievert Universal Torch Handle



- Plastic composite handle reinforced with 30% glass for maximum durability
- Bayonet fitting for burners
- Valve for precise flame setting
- 7.1" long x 3.1" height
- Piezo ignitor with instant trigger on/off function

- Swivelling hose connection to avoid hose drag
- Combined suspension hook and footstand

P/N 9700-47734

Sievert 10' Gas Hose



- Rubber/plastic composition
- 1/4" I.D. with LH 9/16" female connections on both ends
- U/L and CGA approved

P/N 9700-47735

Sievert Hose/Preset Regulator Assembly



- 4 ft. hose/preset regulator assembly
- 28 psi (disposable cylinder)
- Hose is rubber/plastic composition
- 1/4" I.D. with LH 9/16" female connections on both ends

- U/L and CGA approved

P/N 9700-47737

AIRCRAFT ~~A~~ DYNAMICS™



PISTOL GRIP IMPACT WRENCH

P/N 9706-37356 2008 7/16" Hex Quick-Change
 P/N 9706-37357 2010 1/2" Square Drive
 P/N 9706-37358 2016 3/4" Square Drive

Powered by Variable Voltage Robopaks or other DC power sources, Roboimpacts are so versatile they can be powered between 24v - 36v, providing up to 2500 impacts per minute and 450+ ft./lbs. of torque. Roboimpacts are used by linemen and professional workers all over the world. They are also standard issue items on many military vehicles. Unmatched in power, durability and reliability!

D-HANDLE IMPACT WRENCH

P/N 9706-37359 2001 7/16" Hex Quick-Change
 P/N 9706-37360 2002 1/2" Square Drive
 P/N 9706-37361 2004 5/8" Hex Quick-Change



- Extremely powerful and fast!
- Attached 8 ft. cords plug into Robopaks for versatile power tool needs.
- Powerful 30 amp reversible motors provide 450+ ft./lbs. of torque and 2500 impacts per minute.
- Reversing switches located on high strength, impact resistant handles.
- Secondary 2-position attachable handles provide added control.

ROBO PAKS

P/N 9702-40718 3481 XL-9280
 P/N 9701-86313 5228 Powers Huskie Tools
 Includes: Adapter, XL 9280 Robopak, and AC Charger
 P/N 9701-86315 5060 Powers 14.4V Burndy, Makita, Stanley, Cembre Tools
 Includes: Adapter, XL 9280 Robopak, and AC Charger
 P/N 9701-86316 5061 Powers EK425 Greenlee Tools
 Includes: Adapter, XL 9280 Robopak, and AC Charger



The ultimate in portable power, the XL9280 is a small and versatile Variable Voltage power source. It will power all Robotools and hundreds of other tools, lights and equipment that require up to 28v to operate. Dramatically increase the run times (up to 30 times) of your Huskie, Burndy, Cembre, Stanley, Greenlee, Makita, DeWalt, Milwaukee, Fairmont, Hilti and other battery powered tools!

- Dimensions: 9-3/8" L x 6-1/4" W x 5-5/8" D
- Weight: 18 lbs.



ROBO
I
M
P
A
C
T
S

POWER TOOLS
ELECTRIC POWERED TOOLS

USA: 1-877-GO ALTEC
(1-877-462-5832)

www.alteconnect.com

Milwaukee **ELECTRIC TOOLS**

Nothing But **HEAVY DUTY**®

**POWER TOOLS
ELECTRIC POWERED TOOLS**

USA: 1-877-GO ALTEC
(1-877-462-5832)

www.alteconnect.com

1 3/4" SDS-Max Rotary Hammer

- 14 Amp, 1,300 MWO motor
 - 450 RPM and 2,840 BPM - delivers fast drilling even in the toughest concrete
 - AVS: Anti Vibration System- actively reduces user vibration and increases productivity
 - 2 Speed Impact Mode
 - Constant Power Technology
 - Mechanical Clutch
- P/N 9701-98903 5426-21



Ground drivers
and concrete drilling
P/N 9701-99370



Ground drivers
and concrete drilling
P/N 9701-98903

2" SDS-Max Rotary Hammer

- High blow energy 19.9 ft-lbs
 - User-friendly vibration isolation system
 - Heavy-duty robust construction
 - In-line design; 3 side handle positions
 - Variable speed control dial
 - Service reminder light
 - Soft-grip on all handles
 - Uses standard SDS-Max accessories
- P/N 9701-99370 5342-21

Hex Quick-Change Impact Wrench

- High torque - 315 ft. lbs.
- Quick-change hex retention system
- Bracket and steel ring for easy transport
- Great balance and soft-grip handle
- Variable speed switch for maximum user control, 600-1,800 RPM



P/N 9701-55561 9092-20 120 AC 7/16" Hex
P/N 9701-98851 9096-20 120 AC 5/8" Hex

11 Amp 4-1/2" Small Angle Grinder Paddle, Lock-On



- Powerful 11 Amp, 11,000 RPM Motor: for maximum performance/durability
- Tool-Free Accessory Change
- Tool-Free Adjustable Guard
- Advanced Airflow System: Maximizes airflow and reduces debris ingress, improving motor life and performance
- Debris Baffles – protect internal components by deflecting damaging debris out of the airflow at the intake vents
- Includes (1) 11 Amp 4-1/2" Small Angle Grinder Paddle, Lock-On -6147-30, Type 27 Guard, Side Handle, Spanner Wrench, Flanges

P/N 9703-51278 6147-30
P/N 9703-51280 6147-31 Includes Paddle Switch with Lock
P/N 9703-51281 6146-33 Includes Slide with Lock

13 Amp Orbital Super Sawzall® Reciprocating Saw

- 13 Amp Milwaukee-built motor
 - Orbital cutting action
 - 1 1/4" stroke
 - Variable speed trigger, 0-3000 SPM
 - Quik-lok™ blade clamp
 - Counter-balanced/gear protection Systems
- P/N 9701-98904 6536-21



Please contact your Altec Supply Account Manager for more information regarding Milwaukee's Power Tools.



Pkg. of 3 Bi-Metal Band Saw Blades



- Bi-Metal Construction
- Matrix II high speed steel teeth with 8% cobalt
- P/N 9701-98905 is for cutting stock 3/16" to 5/16" thick
- P/N 9701-98906 is for cutting stock 5/32" to 3/16" thick
- For use with portable band saws using 44 7/8" x 1/2" x .020" blades

P/N 9701-98905 48-39-0511 14 TPI 44 7/8" Pkg of 3
 P/N 9701-98906 48-39-0521 18 TPI 44 7/8" Pkg of 3

Deep Cut Variable Speed Band Saw Kit



- Powerful 11 Amp Motor w/ CPT™ : Provides maximum performance/durability
- Job Site Armor™ Technology: Proprietary composite material and crush zone barriers provide long lasting rugged protection
- All Metal Direct Drive delivers maximum tool life while requiring less servicing than a chain drive
- Gear Protecting Clutch: Extends gear and motor life by absorbing high impact forces caused by blade lock-ups
- CPT™ Constant Power Technology: Maintains cut speed in the toughest applications for optimal performance
- Revolutionary Cut Visibility: Slimmer motor housing increases user line of site delivering superior cut accuracy
- Balanced Body Design and Lighter Weight (14.5 Lbs.)
- LED Light: Illuminates work surface for increased accuracy and productivity
- Tool-Free Locking Adjustable Shoe - adjust from an extended shoe to no shoe in seconds
- Industry's Largest Cut Capacity: cut up to 5" by 5" material in one pass and adjustable shoe allows for less tool rotation when cutting material above 5"
- Debris Protection System: Delivers longer pulley life by removing debris during use

P/N 9703-51292 6232-21

12 Amp Sawzall® Reciprocating Saw Kit with Case



- Powerful 12 Amp Motor: Delivers 0-3,000 SPM for high performance cutting in a variety of materials
- 3/4" Stroke Length: Provides maximum cut control
- Gear Protecting Clutch: Extends gear and motor life by absorbing high impact forces caused by blade lock-ups
- Counter Weighted Mechanism: Provides reduced vibration for smoother operation
- QUIK-LOK™ Blade Clamp: Provides fast , tool-free blade changes
- Includes Sawzall® Recip Saw and Carrying Case

P/N 9701-82920 6509-31

POWER TOOLS
ELECTRIC POWERED TOOLS

USA: 1-877-GO ALTEC
 (1-877-462-5832)

www.alteconnect.com

Please contact your Altec Supply Account Manager for more information regarding Milwaukee's Power Tools.

Recipro Saw

Anti-Vibration Technology for 2X Less Vibration

- Powerful 15.0 AMP motor with 0-2,800 SPM
- Electronic speed control maintains constant speed under load
- Built-in clutch reduces gear damage by disengaging gears if blade binds
- 4-position orbital/straight cutting action
- Variable speed control dial enables user to match the speed to the application
- Long 1-1/4" stroke for faster cutting
- "Tool-less" blade change and shoe adjustment
- Ergonomically designed rubberized grip for more comfort
- Anti-vibration technology for 2x less vibration

P/N 9705-88758 JR3070CT

Electric Reciprocating Saw



AVTTM
Anti Vibration Technology



Portable Band Saw Kit

Large 4-3/4" x 4-3/4" Cutting Capacity

- Powerful 6.5 AMP motor delivers 200-350 ft./min. for cutting in a wide variety of materials
- Dual bearing blade guides and adjustable stopper plate
- Variable speed control dial enables user to match the speed to the application
- Blade tightening lever for fast and easy blade installation
- Accepts standard 44-7/8" x 1/2" blade

P/N 9705-88759 2107FK Portable Band Saw Kit

4-1/2" Angle Grinder

- Powerful 10.0 AMP motor delivers more output and 10,500 RPM for the most demanding applications
- Super Joint System® (SJS) technology helps prevent motor and gear damage by allowing the drive shaft to slip if the wheel is forced to a stop
- Larger cooling fan and blades pull more air through the motor to help maintain lower operating temperature
- "Tool-less" wheel guard adjustment for easy adjustment
- Large flush-mount paddle switch with lock-off for comfortable operation
- Spiral bevel gears for smoother rotations and a more efficient transfer of energy
- Protective zig-zag varnish protects the armature coil by deflecting dust and debris
- Labyrinth construction seals and protects the motor and bearings from dust and debris for longer tool life
- AC/DC switch for use with alternative power sources

P/N 9705-88760 9564P

4-1/2" Angle Grinder



Shown with Optional Grinding Wheel

COOPER POWER PNEUMATIC IMPACT WRENCH

Cooper Power Systems Impact Wrench - Pistol Grip, Trigger Start



- Telescopic impact wrench
- Patented positive lock socket retainer - sockets snap on and stay on until released
- Exclusive through-bolt construction reduces replacement costs; steel front end/motor housing/handle are clamped together by four high strength bolts
- Positive oil-foam lubrication system reduces major cause of impact wrench maintenance; unique oil foam bath that provides positive lubrication for the hammer, anvil, and other working parts
- Proven heavy duty patented telescoping impact mechanism adds power, cuts weight, and reduces shock to operator
- Comfortable grip handle, throttle may be feathered for speed control
- Simple face-type reversing valve simplifies maintenance
- Forged hammer and anvil for greater durability
- Rotor bearings and steel motor end plates fit either end of motor, reducing spare parts inventory and repair time
- 37-370 ft-lbs. of torque; 1,400 impacts/minute; 6,500 RPM

P/N 9000-70265 WP-455-4R Impact Wrench Cleco 1/2" Square Drive
 P/N 9000-70266 APX WR-514 Quick Change Adapter; 1/2" FSQ Drive x 7/16" Hex

PASLODE PNEUMATIC 16 GAUGE UTILITY STAPLER



- Lightweight, reducing operator fatigue
- Quick-clear feature provides easy access to nose should staple jam occur
- Cordless stapler drives 3/4" to 2" staples
- Drives approximately 4,000 staples on a full charge; drives 2,400 staples per fuel cell
- Shoots up to 10 staples per second, greatly reducing the time and effort of driving staples into place - less than half the time of driving by hand
- P/N 9701-35044 are stainless steel staples with a chisel point, 1.5" leg length, 1/2" wide, and are available in a quantity of 10,000

P/N 9701-33105 IM2000-S16 Stapler
 P/N 9701-35044 8612PS-10M Staples - Qty of 10,000
 P/N 9701-35047 402500 Impulse Stick Battery
 P/N 9703-80209 & 9703-80210 Fuel Cell (2 pack)
 P/N 9701-35050 219086 Degreaser

P/N 9701-35052 401482
 P/N 9701-35053 219247
 P/N 9701-35075 900200
 P/N 9701-35076 900507

Lubricating Oil
 High Altitude Valve
 Charger
 Car Adapter

AMERICAN PNEUMATIC BACKFILL TAMPER

- The APT Model 131 Backfill Tamper is used for soil compaction, temporary filling of holes, asphalt packing, etc.
- Applications range from foundation and pavement repair to the installation of power and telephone poles
- Built-in automatic oiler
- Flapper valve design allows dirt to pass without stopping the tool
- The half-moon shaped pole butt is for compaction around a pole and the 3" butt is for confined space compaction

	9701-20318 (5214)	9703-46635 5214-03	9703-46636 5214-04
Butt Type	6" Butt	3" Butt	Pole Butt
Bore diameter	1-1/2"	1-1/2"	1-1/2"
Stroke	5-1/2"	5-1/2"	5-1/2"
BPM	670	670	670
CFM at 90psi	38-42	38-42	38-42
Weight	37 lbs	37 lbs	37 lbs
Length	51-7/8"	51-7/8"	51-7/8"
Air Inlet Size	1/2" Female NPT	1/2" Female NPT	1/2" Female NPT

9703-46635 (Left)
 9701-20318 (Middle)
 9703-46636 (Right)



Individual Accessories: P/N 9701-99809 260 6" Diameter Butt

PTO Underdeck Air Compressor Systems



**THE PIONEER
IN PTO TECHNOLOGY**



Shown: 60-200 CFM kit



Shown: 90-200 CFM Ford® 4x4 kit with Thru-Drive™ technology

DESCRIPTION	VAN AIR
60-85 CFM up to 150 PSI	U90085*
Ford® 100 CFM up to 150 PSI.....	UF90100*
125-185 CFM up to 150 PSI	U90185*
Ford® 125-185 CFM up to 150 PSI	UF90185*
185+ CFM up to 150 PSI	U90200*
For Ford® Super Duty 4x4 must use Thru-Drive™ Transfer Case Kit.....	TD904X4*
For Dual Pressure 100/150 PSI Kit	DP90150*

Plug and play speed control, PTO and driveline sold separately.

* Please call 1-877-GO-ALTEC (1-877-462-5832) to order your compressor systems. To ensure the proper configuration for your needs, please have specific vehicle information available: Truck Model, Engine Type, Transmission Type, CFM needs, and primarily cold weather or warm weather activity.

**AIR COMPRESSION
PNEUMATIC EQUIPMENT**

**USA: 1-877-GO ALTEC
(1-877-462-5832)**

Hydraulic Air Compressor Systems

DESCRIPTION	VAN AIR
60-85 CFM up to 150 PSI	UH90085*
125-185 CFM up to 150 PSI	UH90185*
185+ CFM at 150 PSI	UH90200*

Plug and play speed control, PTO and drive-line sold separately.



Shown: 60-85 CFM kit



Genair® Air Compressor Systems

DESCRIPTION	VAN AIR
6.6 kW Continuous 125-185 CFM.....	G66185*
Ford® 6.6 kW Continuous 125-185 CFM....	GF66185*
9.6 kW Continuous 125-185 CFM.....	G96185*
Ford® 9.6 kW Continuous 125-185 CFM....	GF96185*
For Ford® Super Duty 4x4 must use Thru-Drive™ Case Kit.....	TD904X4*
For Dual Pressure 100/150 PSI Kit.....	DP90150*
For Dual Voltage 6.6 kW Kit.....	DV90066*
For Dual Voltage 9.6 kW Kit.....	DV90096*

Plug and play speed control, PTO and driveline sold separately.



Shown: Genair® 125-185 CFM kit



Shown: Genair® Ford® 125-175 CFM kit with Thru-Drive™ technology

Product improvement is a continuing goal. Design, images and specifications are subject to change without notice or obligations. August 2014.

www.alteconnect.com



VAN AIR[®]
MOBILE POWER SOLUTIONS

V3™ Multi-Drive System

Three types of power...one PTO. Air, AC Power, SAE B Pad Provision.



Shown: Genair® Weatherproof 125 - 185 CFM Kit

DESCRIPTION	VAN AIR
6.6 kW 125-185 CFM, SAE B pad.....	V366185*
Ford® 6.6 kW 125-185 CFM, SAE B pad.....	V3F66185*
9.6 kW 125-185 CFM, SAE B pad.....	V396185*
Ford® 9.6 kW 125-185 CFM, SAE B pad.....	V3F96185*
For Ford® Super Duty 4x4 must use:	
Thru-Drive™ Case Kit	TD904X4*
For Dual Pressure 100/150 PSI Kit	DP90150*
For Dual Voltage 6.6 kW Kit	DV90066*
For Dual Voltage 9.6 kW Kit	DV90096*

Plug and play speed control, PTO and driveline sold separately.



Shown: Genair® Weatherproof Ford® 125 - 185 CFM Kit with Thru-Drive™ technology and SAE B Pad

**YOUR MOBILE POWER
SOLUTION PROVIDER
SINCE 1972™**

* Please call 1-877-GO-ALTEC (1-877-462-5832) to order your compressor systems. To ensure the proper configuration for your needs, please have specific vehicle information available: Truck Model, Engine Type, Transmission Type, CFM needs, and primarily cold weather or warm weather activity.

Hydraulic Power Unit

Turn the power on with the engine off.

HPU (Hydraulic Power Unit)
P/N 9706-37387 051259

Up to 13 gpm and 3000 PSI, 250 amps,
12V charge, alternator provides up to 250
amps



Product improvement is a continuing goal. Design, images and specifications are subject to change without notice or obligations. August 2014.



**AIR COMPRESSION
PNEUMATIC EQUIPMENT**

USA: 1-877-GO ALTEC
(1-877-462-5832)

www.alteccconnect.com



VAN AIR[®]
MOBILE POWER SOLUTIONS

Above Deck Air Compressor Systems

AIR COMPRESSION
PNEUMATIC EQUIPMENT

Ideal choice for mechanic and service trucks.



RC 40 Reciprocating P/N 9706-37388 050844

CFM Ratings	Air PSI (up to)	Hyd. (gpm)	Hyd. (psig)
30-40	150-175	11.3 - 12.0	1520 - 2000

Ideal for applications in the tire and mechanic service markets for pneumatic tools.



Tiger Hydraulic Rotary Screw P/N 9706-37389 050239

CFM Ratings	Air PSI (up to)	Hyd. (gpm)	Hyd. (psig)
30-45	150-175	10.0 - 16.8	1780 - 2400



Reliant Series Rotary Screw P/N 9706-37390 051167

CFM Ratings	Air PSI (up to)	Hyd. (gpm)	Hyd. (psig)
60-85	100-175	14.0 - 21.5	2250 - 2900



ADHD Hydraulic Rotary Screw P/N 9706-37391 50213

CFM Ratings	Air PSI (up to)	Hyd. (gpm)	Hyd. (psig)
125-185	100-150	27.6 - 44.2	2100 - 2900

Product improvement is a continuing goal. Design, images and specifications are subject to change without notice or obligations. August 2014.

USA: 1-877-GO ALTEC
(1-877-462-5832)

www.alteconnect.com





VANAIR[®]
MOBILE POWER SOLUTIONS

Air N Arc[®] ALL-IN-ONE Power Systems[®]

welder | generator | air compressor | battery boost/charge | hydraulic pump

**AIR COMPRESSION
PNEUMATIC EQUIPMENT**

**USA: 1-877-GO ALTEC
(1-877-462-5832)**

www.alteconnect.com

Designed for light to medium industrial repair. Optional battery booster.



Air N Arc[®] 150 Reciprocating

P/N 9704-00060 050680 - 30 gallon air storage, 12 gallon fuel storage, 12/24 battery charge/boost

20 CFM, 150 PSI, 5kW peak watts, 120V/240V generator, 150 amp high frequency CC/DC at 100 duty cycle welder, 10 gallon, 30 gallon, or remote tank air storage capacity, Kohler engine.

Perfect machine for medium to heavy industrial work. Optional battery booster.



Air N Arc[®] 250 Reciprocating

P/N 9706-37392 050018 - 30 Gallon Air Storage, 12 Gallon Fuel Storage, Remote Mount Control Panel, No Weld / Boost Cables

24 CFM, 175 PSI, 5kW continuous watts, 20V/240V generator, 250 amp high frequency CC/DC at 100 duty cycle welder, 300 amp 12V charge and 12V/24V boost, 30 gallon or remote tank air storage capacity, Kohler engine.

The welder, generator, air compressor and battery booster...ultimate workshop in a box.



**TIER 4
COMPLIANT**

Air N Arc[®] 300 Rotary Screw Available in gas, diesel, and hydraulic.

P/N 9704-00061 050518 - Air N Arc[®] 300 Gas; 12 gallon fuel tank, no weld/boost cables

P/N 9703-08038 050590 - Air N Arc[®] 300 Diesel; 12 gallon fuel tank, no weld/boost cables

P/N 9706-37393 050735 - Air N Arc[®] 300 Hydraulic

40 CFM, 175 PSI, 7kW continuous watts, 120V/240V generator, high frequency welding CC/DC CV/DC 40-300 amps operating range, 270 amps at 100% duty cycle, 300 amp 12V charge and 12V/24V boost, 30 gallon or remote tank air storage capacity, Kohler engine.

Six forms of power in an ALL-IN-ONE[®] Power System



Air N Arc[®] I-300 Rotary Screw

P/N 9706-37394 050790 - No weld/boost cables

40 CFM, 175 PSI, 7kW continuous watts, 120V/240V generator, high frequency welding CC/DC CV/DC 40-300 amps operating range, 270 Amps at 100% duty cycle, 300 amp 12V charge and 12V/24V boost, up to 10.5 GPM & 3000 maximum PSI hydraulic pump, 30 gallon or remote tank air storage capacity, Kubota engine.

Product improvement is a continuing goal. Design, images and specifications are subject to change without notice or obligations. August 2014.





VAN AIR[®]
MOBILE POWER SOLUTIONS

Engine Drive Air Compressor Packages

Designed to fit your air and electrical power needs.



Contractor Reciprocating

- P/N 9706-37395 050711 - 10 gal. air storage, 1.75 gal. fuel storage
- P/N 9706-37396 050712 - 30 gal. air storage, 1.75 gal. fuel storage
- P/N 9706-37397 050713 - no air storage, 1.75 gal. fuel storage

20 CFM, 150 PSI, 4.2 kW continuous 120V/240V generator, 10 gallon, 30 gallon, or remote tank air Storage Capacity, Kohler Engine.



Meets the demands for convenience and mobile air at an economical cost.



PRO 18 & PRO 35 Reciprocating

PRO 18

- P/N 9706-37398 050761 Kohler, 050763 Honda 18.5 CFM, 150 PSI, 10 gal. tank
- P/N 9706-37399 050764 Kohler, 050765 Honda 18.5 CFM, 150 PSI, 30 gal. tank

PRO 35

- P/N 9706-37400 050780 Honda, 050781 Kohler 35 CFM, 170 psi, skid mount
- P/N 9706-37401 050782 Honda, 050783 Kohler 35 CFM, 170 psi, 30 gal. tank

Gas-powered transportability.



**TIER 4
COMPLIANT**

Viper Gas Engine Drive Rotary Screw

(also available with 40 CFM, 5kW generator)

- P/N 9706-37402 050139 - 60 Viper
- P/N 9706-37403 050136 - 70 Viper
- P/N 9706-37404 050216 - 80 Viper

CFM Ratings	Air PSI (up to)	RPM	Engine
60-80	100-150	3500-3600	Kohler

Rugged. Versatile. Dependable. Features automatic variable throttle.



**TIER 4
COMPLIANT**

Viper Diesel Rotary Screw

- P/N 9706-37405 050848 - 60 Viper Diesel
- P/N 9706-37406 050846 - 80 Viper

CFM Ratings	Air PSI (up to)	RPM	Engine
60 - 80	100-150	3500 - 3600	Kubota

Product improvement is a continuing goal. Design, images and specifications are subject to change without notice or obligations. August 2014.

AIR COMPRESSION
PNEUMATIC EQUIPMENT

USA: 1-877-GO ALTEC
(1-877-462-5832)

www.alteconnect.com



Chance Grade 5H built by Atec Supply

Please call 1-877-GO ALTEC (1-877-462-5832) for additional information. Atec Supply will build grounds with Chance Grade 5H per ASTM F855 Rated Grounding Components to your specifications. Please note that Grade 5H grounds must be assembled with 4/0 cable.



CHANCE®
Grade 5H Clamps

5H Rated Grounding Sets

Typical C-Clamp Set

- (2) Chance® P/N 9703-22650 T6000658 C-Clamps
- (2) Chance® P/N 8110-01191 C6002625 Shrouded Ferrules
- (3) P/N 8780-70982 P6001593 Shrink Tube
- 4/0 Copper Cable*
- Grade 5H Label

* 4/0 Cable is a required key component for use with Grade 5H Ground Sets

CHANCE® GROUNDING COMPONENTS

5H Rated built by Atec Supply



9703-22650

9704-90388

9000-01584

9704-90578

9000-60197

9704-90390

CHANCE® 5H Rated Ball Stud Ground Clamps

Clamp	9703-22650 T6000658	9000-60197 C6000197	9704-90388 T6000819	9704-90390 C6001783	9704-90578 C6000085
Continuous Current (Amps)	400	400	400	400	400
Recommended Torque (in-lbs.)	250	250	300	300	250
Main Line Range	#6 Solid Cu. (0.162) to 2" O.D. Bus	#6 Solid Cu. (0.162) to 950 kcmil Cu. 1510 kcmil ACSR	4/0 Str. Cu. (0.500) to 4" x 4" Square 4.5" O.D. Bus	1/8" to 3/4" x 5" Angles or Flats or 5/8" O.D. Rod	2" Structural Angles
ASTM Designation	Type I Class A Grade 5H	Type I Class B Grade 5H	Type I Class A Grade 5H	Type III Class B Grade 5H	Type III Class B Grade 5H

CHANCE® 5H Rated Ball Stud Ground Clamps



Ball Stud Ground Clamp
accepts 30 mm Ball Studs
Grade 5H Rated
P/N 9704-90376
PSC6003494



Short Ball Stud
30 mm Ball
5/8-11 UNC Female Threads
P/N 9704-90378
PSC6003493



Short Ball Stud
30 mm Ball
5/8-11 UNC Threads
P/N 9704-90379
PSC6003491



Long Ball Stud
30 mm Ball
5/8-11 UNC Threads
P/N 9704-90384
PSC6003492

4 Hole NEMA Pad Adapter
with permanent short Ball Stud
P/N 9706-07906 PSC6003510



- GRADE 5H RATED**
- Rated 47kA with X/R = 30
 - First cycle current peak = 126 kA
 - Last cycle current peak = 70 kA
 - Test duration = 15 cycles

GROUNDING & MECHANICAL JUMPER ASSEMBLIES

GROUNDING EQUIPMENT

USA: 1-877-GO ALTEC
(1-877-462-5832)

www.alteconnect.com

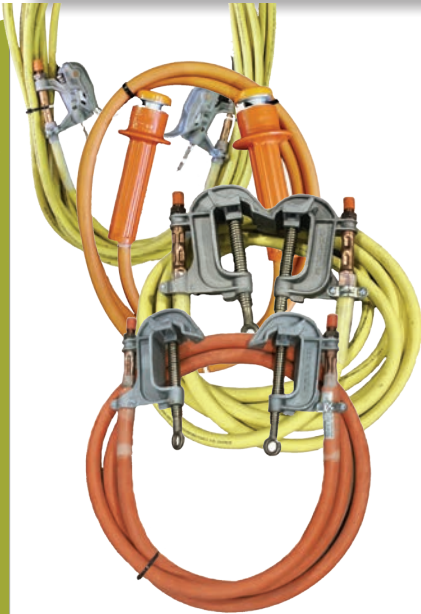

ORDERING A GROUNDING OR JUMPER ASSEMBLY

- 1) **Specify Cable Type**
(600 Volt Grounding Cable is Yellow; 15 kV, 25 kV, 35 kV Jumper Cable is Orange)
- 2) **Specify Cable Length**
- 3) **Specify Cable Size** (#2, 1/0, 2/0, or 4/0)
- 4) **Specify Shrouded or Unshrouded Ferrule**
- 5) **Specify Threaded or Unthreaded Ferrule**
- 6) **Specify Clamp Style** (Standard C-Clamps, Duckbill, Barehand, Flat-faced, etc.)

Altec Supply maintains stock of our best-selling grounding assemblies for same day and next-day shipment availability for rush orders.

Grounding assemblies are tested for resistance, tagged with resistance value, and dated. Heat shrink is applied to protect from water penetration, providing a barrier to resist moisture and corrosion and providing a positive stress relief of grounding cables at their terminations.

Grounding Cable

PART NUMBER	CABLE SIZE	VOLTAGE CLASS	STRANDING	CABLE O.D.	CONTINUOUS CURRENT	WEIGHT
P/N 692-96066	#2	600 VOLTS	19/35/30	0.475"	150 AMPS 50' -100' 100 AMPS 100' +	270 LBS./1000'
P/N 692-96067	1/0	600 VOLTS	19/55/30	0.575"	250 AMPS 50' -100' 250 AMPS 150' +	418 LBS./1000'
P/N 692-96068	2/0	600 VOLTS	19/70/30	0.635"	300 AMPS	542 LBS./1000'
P/N 9700-34943	4/0	600 VOLTS	19/111/30	0.78"	500 AMPS	843 LBS./1000'



Copper Mechanical Jumper Cable

PART NUMBER	CABLE SIZE	VOLTAGE CLASS	STRANDING	CONDUCTOR DIAMETER	CABLE O.D.	CONTINUOUS CURRENT	WEIGHT
P/N 9701-56145	#2	15 kV	259/#26	0.322"	0.779"	200 AMPS	0.438 LBS.
P/N 9700-40574	1/0	15 kV	413/#24	0.404"	0.863"	260 AMPS	0.598 LBS.
P/N 9700-40576	2/0	15 kV	273/#23	0.455"	0.914"	300 AMPS	0.707 LBS.
P/N 9007-11001	4/0	15 kV	473/#21	0.602"	1.065"	400 AMPS	1.047 LBS.
P/N 9700-40519	1/0	25kV	413	0.404"	1.113"	260 AMPS	0.801 LBS.
P/N 9700-40518	2/0	25kV	266	0.450"	1.160"	300 AMPS	0.903 LBS.
P/N 9701-55351	1/0	35kV	413	0.404"	1.287"	260 AMPS	0.985 LBS.



Please call 1-877-GO ALTEC (1-877-462-5832) for more information.

GROUNDING FERRULES & JUMPER CLAMPS

Grounding Ferrules

Shrouded ferrules overlap onto the grounding cable jacket for stress relief to the terminal. Two crimps secure the ferrule against the bare strands and one crimp applies on the jacket.

Unshrouded ferrules are available with shrink tubing that overlaps the bare cable conductor and jacket for stress relief.

Available either factory-installed in pairs on any cable length specified or as separate individual units, the ferrules install simply with a hydraulic crimping tool. Complete illustrated installation instructions come with the ferrules and include a table for the crimping die sizes to use.



Shrouded, Threaded



Unshrouded, Threaded



Unshrouded, Unthreaded



Shrouded, Unthreaded

Shrouded Plain Copper Ferrules For Pressure Type Grounding Clamp Terminals

P/N 692-96140	C6002630	Cable Size #2
P/N 8110-01059	C6002631	Cable Size 1/0
P/N 9700-13097	C6002632	Cable Size 2/0
P/N 9700-03626	C6002633	Cable Size 4/0

Unshrouded Plain Copper Ferrules For Pressure Type Grounding Clamp Terminals

P/N 9700-40145	C6002614	Cable Size #2
P/N 692-96133	C6002615	Cable Size 1/0
P/N 692-96117	C6002616	Cable Size 2/0
P/N 9700-40146	C6002617	Cable Size 4/0

Shrouded, Threaded-Stud Copper Ferrules For Tapped or Drilled Grounding Clamp Terminals

P/N 9000-02622	C6002622	Cable Size #2
P/N 8110-01060	C6002623	Cable Size 1/0
P/N 8780-71022	C6002624	Cable Size 2/0
P/N 8110-01191	C6002625	Cable Size 4/0

Unshrouded, Threaded-Stud Copper Ferrules For Tapped or Drilled Grounding Clamp Terminals

P/N 692-96058	C6002606	Cable Size #2
P/N 692-96059	C6002607	Cable Size 1/0
P/N 685-20154	C6002608	Cable Size 2/0
P/N 9007-02609	C6002609	Cable Size 4/0

G4758 Jumper Clamp



- Handle length of 5.625" below the handguard
- The bearing type floating washer lower contact improves gripping action and prevents conductor scoring
- All metal parts are made of copper alloy to improve resistance to oxidation
- 300 amp continuous current rating is based on using 2/0 jumper cable on the tap side
- Voltage Class 15 kV
- Main Line Range: 0.162" to 0.721"
- Jumper Cable Range: #2 to 2/0 Cable
- 2.25 lb.

P/N 9700-40135 G4758 Pair
P/N 9007-60100 T601-0003 Individual Clamp

G4765 Jumper Clamp



- Features the same polyethylene material in the handle as other Chance jumper clamps
- The handle length below the handguard is 7.5"
- 400 amp continuous current rating is based on using 4/0 jumper cable on the tap side
- Voltage Class 25 kV
- Main Line Range: 0.162" to 0.883"
- Jumper Cable Range: #2 to 4/0 Cable
- 2.75 lb.

P/N 9700-05084 G4765 Pair
P/N 9701-07887 T6010039 Individual Clamp

G4775 Jumper Clamp



- Features a larger contact opening for use on larger conductor distribution lines
- The handle length below the handguard is 8.375"
- Easy to assemble, the connector assemblies are interchangeable between the two sizes of 15 kV Jumper Clamps
- 400 amp continuous current rating is based on using 4/0 Jumper Cable on the tap side
- Voltage Class 35 kV
- Main Line Range, 0.162" to 1.165"
- Jumper Cable Range, #2 to 4/0 Cable
- 3 lb.

P/N 9700-40136 G4775 Pair
P/N 9701-07890 T6010040 Individual Clamp

GROUNDING EQUIPMENT

**USA: 1-877-GO ALTEC
(1-877-462-5832)**

www.alteconnect.com

Please contact 1-877-GO ALTEC (1-877-462-5832) for additional information regarding Chance products.

C-TYPE GROUNDING CLAMPS

GROUNDING EQUIPMENT

USA: 1-877-GO ALTEC
(1-877-462-5832)

www.alteconnect.com

PSC6003412 C-Type Clamp



- Jaw Opening Size: 0.162" to 2"
- Fault Current Rating: ASTM Grade 5
- Material: Aluminum
- Terminal Type: Drilled for use with Threaded Ferrules
- Handle Type: Eyescrew
- Jaw Type: Serrated Jaws
- Continuous Current: 400 Amps
- Fault Current:
 - 15 cycles 43,000 Amps
 - 30 cycles 30,000 Amps
- Recommended Torque: 250 in-lb.
- Jumper Range: #2 to 4/0 Cable with Threaded Terminal
- 1.75 lb.

P/N 9007-03412 PSC6003412

C6001754 C-Type Clamp

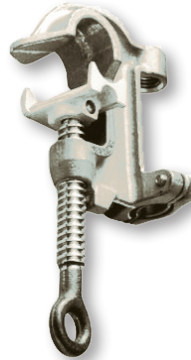

- Jaw Opening Size 0.128" to 0.998"
- Fault Current Rating ASTM Grade 3
- Material: Aluminum
- Terminal Type: 5/8"-11 Thread
- Handle Type: Eyescrew
- Smooth Jaws
- Continuous Current: 300 Amps
- Fault Current - 15 cycles 43,000 Amps
30 cycles 30,000 Amps
- Recommended Torque 250 in-lb.
- Jumper Range: #2 Cable to 2/0 Cable with Threaded Terminal
- 1 lb.

P/N 9000-61754 C6001754

G3369 Bus-Bar Clamp



- Jaw Opening Size 0.368" to 4.5"
- Fault Current Rating ASTM Grade 5
- Material: Aluminum
- Terminal Type: Pressure
- Handle Type: Eyescrew
- Smooth Jaws
- Continuous Current: 400 Amps
- Fault Current - 15 cycles 43,000 Amps
30 cycles 30,000 Amps
- Recommended Torque: 300 in-lb.
- Jumper Range: #2 Cable with Plain Terminal to 4/0 Cable with Plain Terminal
- 5.145 lb.

P/N 9000-40090 G3369

C6002271 C-Type Clamp



- Jaw Opening Size 0.162" to 1.25"
- Fault Current Rating ASTM Grade 5
- Material: Bronze
- Terminal Type: 5/8"-11 Thread
- Handle Type: Eyescrew
- Smooth Jaws
- Continuous Current: 400 Amps
- Fault Current - 15 cycles 43,000 Amps
30 cycles 30,000 Amps
- Recommended Torque 250 in-lb.
- Jumper Range: #2 Cable to 4/0 Cable with Threaded Terminal

P/N 692-96057 C6002271

C6001959 C-Type Clamp

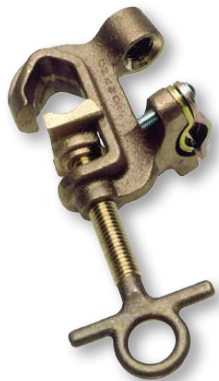

- Jaw Opening Size 0.162" to 0.814"
- Fault Current Rating ASTM Grade 2
- Material: Bronze
- Terminal Type: 5/8"-11 Thread
- Handle Type: Eyescrew
- Smooth Jaws
- Continuous Current 250 Amps
- Fault Current - 15 cycles 43,000 Amps
30 cycles 30,000 Amps
- Recommended Torque: 200 in-lb.
- Jumper Range: #2 to 1/0 Cable with Threaded Terminal
- 1 lb.

P/N 692-96106 C6001959

C6000434 Duckbill Clamp

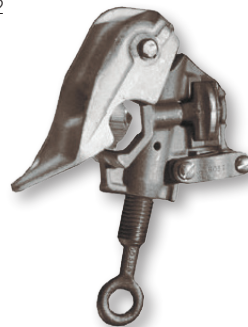

- Jaw Opening Size 1.506" to 0.162"
- Fault Current Rating ASTM Grade 5
- Material: Aluminum
- Terminal Type: Pressure
- Handle Type: Eyescrew
- Serrated Jaws
- Continuous Current 400 Amps
- Fault Current - 15 cycles 43,000 Amps
30 cycles 30,000 Amps
- Recommended Torque: 250 in-lb.
- Jumper Range: #2 Cable to 4/0 Cable with Plain Terminal
- 1.96 lb.

P/N 692-96147 C6000434

Please contact 1-877-GO ALTEC (1-877-462-5832) for additional information regarding Chance products.

C-TYPE GROUNDING CLAMPS

C6002276 C-Type Clamp



- Material: Aluminum
- Fault Current Rating: ASTM Grade 5
- Handle Type: Eyescrew
- Continuous Current: 400 Amps
- Fault Current - 15 cycles 43,000 Amps
30 cycles 30,000 Amps
- Recommended Torque: 250 in-lb.
- Jaw Opening Size: 0.128" to 1.25"
- Terminal Type: Pressure
- Jaw Type: Serrated Jaws
- Jumper Range: #2 to 4/0 Cable with Plain Terminal
- 1.5 lb.

P/N 692-96145 C6002276

C6002281 C-Type Clamp

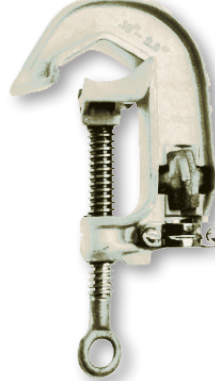

- Jaw Opening Size 0.162" to 2"
- Fault Current Rating ASTM Grade 5
- Material: Aluminum
- Handle Type: Eyescrew
- Continuous Current 400 Amps
- Fault Current - 15 cycles 43,000 Amps; 30 cycles 30,000 Amps
- Recommended Torque: 250 in-lb.
- Terminal Type: Pressure
- Jaw Type: Smooth Jaws
- 2.75 lb.
- Jumper Range - #2 to 4/0 Cable with Plain Terminal

P/N 9700-40195 C6002281

C6001734 Duckbill Clamp



- Material: Aluminum
- Fault Current Rating: ASTM Grade 5
- Handle Type: Eyescrew
- Continuous Current: 400 Amps
- Fault Current - 15 cycles 43,000 Amps; 30 cycles 30,000 Amps
- Recommended Torque: 250 in-lb.
- Jaw Opening Size 0.162" to 1.162"
- Terminal Type: 5/8"-11 Thread
- Jaw Type: Smooth Jaws
- Jumper Range - #2 with Threaded Terminal to 4/0 Cable with Threaded Terminal
- 1.372 lb.

P/N 811-00158 C6001734

C6002255 C-Type Clamp



- Jaw Opening Size 0.162" to 2"
- Fault Current Rating ASTM Grade 5
- Material: Aluminum
- Handle Type: Eyescrew
- Continuous Current 400 Amps
- Fault Current - 15 cycles 43,000 Amps; 30 cycles 30,000 Amps
- Recommended Torque: 250 in-lb.
- Terminal Type: 5/8"-11 Thread
- Jaw Type: Smooth Jaws
- 2 lb.
- Jumper Range - #2 to 4/0 Cable with Threaded Terminal

P/N 9700-34630 C6002255

C6000197 Duckbill Clamp



- Material: Aluminum
- Fault Current Rating: ASTM Grade 5
- Handle Type: Eyescrew
- Continuous Current: 400 Amps
- Fault Current - 15 cycles 43,000 Amps 30 cycles 30,000 Amps
- Recommended Torque: 250 in-lb.
- Jaw Opening Size 0.162" to 1.506"
- Terminal Type: 5/8"-11 Thread
- Jaw Type: Serrated Jaws
- Jumper Range - #2 with Threaded Terminal to 4/0 Cable with Threaded Terminal
- 1.862 lb.

P/N 9000-60197 C6000197

C6002282 C-Type Clamp

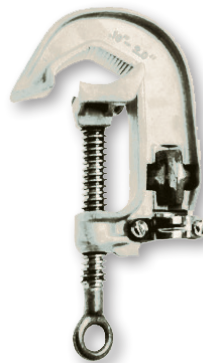

- Jaw Opening Size 0.162" to 2"
- Fault Current Rating: ASTM Grade 5
- Material: Aluminum
- Handle Type: Eyescrew
- Continuous Current 400 Amps
- Fault Current - 15 cycles 43,000 Amps 30 cycles 30,000 Amps
- Recommended Torque: 250 in-lb.
- Terminal Type: Pressure
- Jaw Type: Serrated Jaws
- 2.5 lb.
- Jumper Range - #2 to 4/0 Cable with Plain Terminal

P/N 9700-18946 C6002282

GROUNDING EQUIPMENT

**USA: 1-877-GO ALTEC
(1-877-462-5832)**

www.alteconnect.com

Please contact 1-877-GO ALTEC (1-877-462-5832) for additional information regarding Chance products.

GROUNDING CLAMPS

C6001735 Flat-Face Clamp

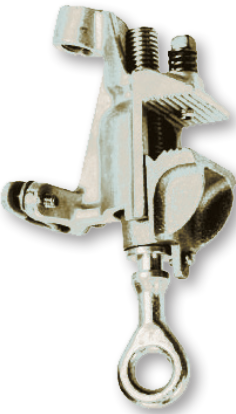

- Flat-Face Clamp
- Jaw Opening Size: 0.125" to 1.5"
- Jaw Type: Serrated Jaws
- Recommended Torque: 250 in-lb.
- Fault Current Rating: ASTM Grade 3
- Material: Aluminum
- Terminal Type: 5/8"-11 Thread
- Handle Type: Eyescrew
- Continuous Current: 300 Amps
- Fault current - 15 cycles 27,000 amps; 30 cycles 20,000 amps
- Jumper range: #2 to 2/0 Cable with Threaded Terminal
- 1.5 lb.

P/N 9700-40203 C6001735

C6002100 Ball Stud Clamp



- Flat-Face Clamp
- Jaw Opening Size: 0.125" to 1.5"
- Jaw Type: Serrated Jaws
- Recommended Torque: 250 in-lb.
- Fault Current Rating: ASTM Grade 5
- Material: Bronze
- Terminal Type: Drilled Terminal
- Handle Type: Eyescrew
- Continuous Current: 400 Amps
- Fault Current - 15 cycles 43,000 Amps; 30 cycles 30,000 Amps
- Jumper Range: #2 cable with Threaded Terminal to 4/0 Cable with Threaded Terminal
- .95 lb.

P/N 9700-37339 C6002100

C6002232 Flat-Face Clamp

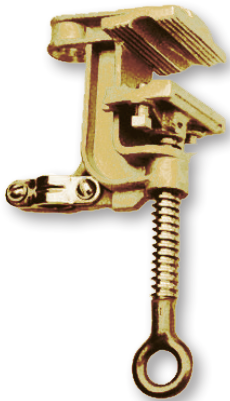

- Flat-Face Clamp
- Jaw Opening: Size 0.125" to 1.5"
- Fault Current Rating: ASTM Grade 5
- Material: Bronze
- Terminal Type: 5/8"-11 Thread
- Handle Type: Eyescrew
- Jaw Type: Serrated Jaws
- Continuous Current: 400 Amps
- Fault Current - 15 cycles 43,000 Amps
- Fault Current - 30 cycles 30,000 Amps
- Recommended Torque: 250 in-lb.
- Jumper Range: #2 to 4/0 Cable with Threaded Terminal

P/N 9700-40209 C6002232

C6002231 Flat-Face Clamp



- Flat-Face Clamp
- Jaw Opening Size: 0.125" to 1.5"
- Jaw Type: Serrated Jaws
- Recommended Torque: 250 in-lb.
- Fault Current Rating: ASTM Grade 5
- Material: Bronze
- Terminal Type: 5/8"-11 Thread
- Handle Type: T-Handle
- Continuous Current: 400 Amps
- Fault Current - 15 cycles 43,000 Amps; 30 cycles 30,000 Amps
- Jumper Range: #2 to 4/0 cable with Threaded Terminal
- 4 lb.

P/N 692-96109 C6002231

T6001798 Grounding Clamp



- Jaw Opening Size: 0.125" to 1.5"
- Fault Current Rating: ASTM Grade 5
- Material: Aluminum
- Terminal Type: 5/8"-11 Thread
- Handle Type: T-Handle
- Jaw Type: Serrated Jaws
- Continuous Current: 300 Amps
- Fault Current - 15 cycles 27,000 Amps; 30 cycles 20,000 Amps
- Recommended Torque: 250 in-lb.
- Jumper Range: #2 to 2/0 Cable with Threaded Terminal
- 1.5 lb.

P/N 9000-61798 T6001798

C60012256 Grounding Clamp



- Jaw Opening Size: 0.162" to 2"
- Fault Current Rating: ASTM Grade 5
- Material: Aluminum
- Terminal Type: 5/8"-11 Thread
- Handle Type: Eyescrew
- Jaw Type: Serrated Jaws
- Continuous Current: 400 Amps
- Fault Current: 15 cycles 43,000 Amps; 30 cycles 30,000 Amps
- Recommended Torque: 250 in-lb.
- Jumper Range: #2 to 4/0 Cable with Threaded Terminal
- 1.75 lb.

P/N 9007-02256 C6002256

Please contact 1-877-GO ALTEC (1-877-462-5832) for additional information regarding Chance products.

GROUNDING CLAMPS

Apparatus Grounding Clamps



P/N 9700-37339 P/N 9700-37530 P/N 8939-42880
P/N 9000-02101

- For restricted-space applications and as a truck-grounding system, this compact design delivers a high-current rating usually associated with only large clamps
- Applies to a wide range of switching equipment, including: Industrial metalclad gear, indoor and outdoor substations, overhead and underground distribution
- For trucks, a ball stud permanently mounts on each body
- Clamp bodies and eyescrews are a bronze alloy
- P/N 9700-36004, P/N 9000-02101, P/N 9700-37530 are designed for threaded stud ferrule on #2-4/0 grounding cable
- P/N 8939-42880 is designed for plain-plug ferrule on #2 to 4/0 grounding cable

Part Number	Chance	Description
P/N 9700-37339	C6002100	Drilled for 5/8-11 UNC Threaded Ferrule
P/N 9000-02101	C6002101	Tapped for 5/8-11 UNC Threaded Ferrule
P/N 9700-37530	T6002320	Tapped for 5/8-11 UNC Threaded Ferrule
P/N 8939-42880	C6002300	Eyescrew with Pressure Terminal

4-Way Terminal Block

- Used to attach ground leads from grounding clamps to a common ground
- Ideal where permanent temporary grounding sets are part of a substation emergency equipment
- Accommodates 4/0 grounding cables with plain ferrules
- Continuous current: 400 amps
- Fault Current: 15 cycles 43,000 Amps; 30 cycles 30,000 Amps
- P/N G4754-1 is for Plain Plug Ferrules
- P/N T6001964 is for Threaded Ferrules

P/N 9701-94321 G4754-1 (pictured)
P/N 9701-94322 T6001964 (not pictured)



Ball Studs



P/N 8780-70912



P/N 692-96086

- For restricted-space applications and as a truck-grounding system, this compact design delivers a high-current rating usually associated with only large clamps
- Applies to a wide range of switching equipment, including: Industrial metal-clad gear, indoor and outdoor substations, overhead and underground distribution
- For trucks, a ball stud permanently mounts on each body
- Ball-studs are bronze alloy and tin-plated; lockwasher and nut are silicone bronze
- Have nominal 1" diameter ball and stud to fit NEMA terminal pads

Part Number	Chance	Overall Length	Stud Length	Type
P/N 8780-70912	C6002102	4.25"	1 13/16"	Standard Ball Stud
P/N 692-96086	T6002364	7"	3 15/16"	Long Ball Stud
P/N 9700-69029	T6002867	3.3"	1.8"	Female Threaded Ball Stud

P/N 692-96087 C4060416 Ball Stud Cover

GROUNDING EQUIPMENT

USA: 1-877-GO ALTEC
(1-877-462-5832)

www.alteconnect.com

Please contact 1-877-GO ALTEC (1-877-462-5832) for additional information regarding Chance products.

GROUNDING ACCESSORIES

Grounding Stud Cover



- This flexible cover fits P/N 8939-95590 or P/N 692-96086 ballstuds
- May help prevent flashover on ball studs installed in enclosed switchgear, switchyards or substations
- An environmental protector to reduce corrosion and

contamination on the ball- stud when energized cover is not intended for personnel protection

- Should not be considered as insulative cover-up equipment
- Provides 400 volts per mil puncture strength
- Resilient ozone/corona-resistant thermoplastic elastomer does not absorb water
- Resists aging/checking and retains high-visibility orange color
- Snap-fit keeps cover in place
- The 5/8" I.D. loop at top permits hot-line tools to "pop" it on and off

P/N 692-96087 C4060416 Ball Stud Cover

Screw Ground Rod



- Provides a temporary ground where a system ground is not available
- When installed, the 6' spiraled ground rod develops less resistance than straight ground rods; however, actual effectiveness depends upon soil properties
- Reusable ground rod is copper clad
- The helix (spiral) handle and wing nut are bronze
- Continuous Current - 400 Amps
- Fast Current - 15 cycles - 43,000 Amps
- Fault Current - 30 Cycles - 30,000 Amps
- 7.6 lb.

P/N 692-96011 G3370

Static Ground Set



- Eliminate the problem of electrostatic charge when working insulator strings
- Drains off the charge from the insulator string to the tower leg
- The adjustable jaws of the Static Ground fit insulator caps from 2 1/2" to 6"
- Overall length with a 1 1/4" x 19" Epoxiglas® pole is 30"

P/N 9700-53462 C6000000

Grounding Assembly Storage Bag



- Easy-to-see, bright yellow protective bag is made of double vinyl laminated open-weave polyester cloth
- Lightweight and durable with nylon stitching throughout
- Plywood bottom is covered inside and out with metal skids on bottom of bag
- Full-separating closure constructed with heavy duty snaps and heavy webbing handles

P/N 9700-48493 T6000865

Heat Shrink Tube - 5" Length



- Clear heat-shrink tubes provide corrosion-inhibitor by excluding moisture and stress-relief for cable jacket and ferrule-to-stranding connection
- Visual inspection of cable condition through clear heat-shrink tube determines breakage or corrosion that otherwise requires continuity test
- Units expose 1/2" of cable strands at junction point

P/N 8780-70982 P6001593

Cluster Grounds



- Compact 5" aluminum-alloy bar (5/8" diameter)
- Accepts C-type or duckbill clamps for phase-to-phase grounding technique
- Adjustable wheel binder and 36" chain for wood-pole applications

P/N 9007-60015 T6001549

Please contact 1-877-GO ALTEC (1-877-462-5832) for additional information regarding Chance products.

GROUNDING EQUIPMENT

Truck Grounding Set

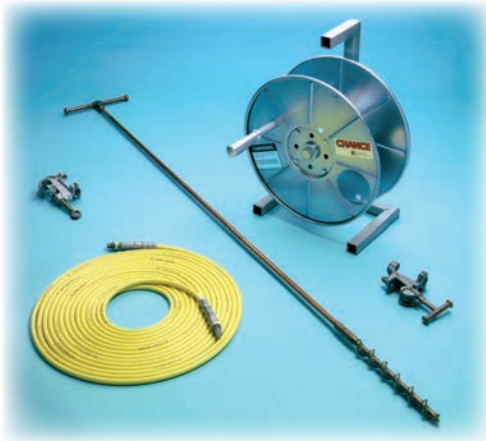

- Convenient set provides means to drain off capacitance or static charges from winch trucks and aerial devices
- Flat face clamp is for secure attachment to the truck bed at an area cleaned for electrical contact
- C-type clamp is for secure attachment to ground rod
- This grounding method should not be considered adequate protection to personnel against conductor contact

Part Number	Chance	Complete Assembly
P/N 683-21002	T6001971	
Includes:		
(1) P/N 692-96011 (G3370)		Screw Ground Rod
(1) P/N 9000-61798 (T6001798)		Flat Face Ground Clamp
(1) P/N 9000-61754 (C6001754)		C-Type Ground Clamp
(1) P/N 9000-06116 (S6116)		C-Type Ground Clamp
(1) P/N 9000-62618 (C6002618A)		Shrouded Aluminum Ferrules
(1) P/N 692-96014 (C4176086)		Storage Reel

EQUI-MAT™ Personal Protective Ground Grid

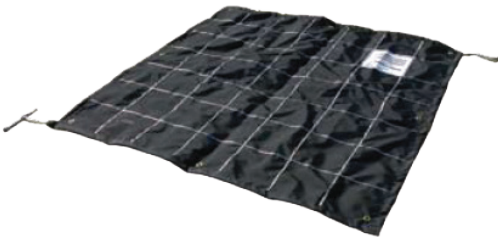

- Provides an easy way to help establish an equipotential zone for a lineworker to stand on during various energized and deenergized work practices
- Properly applied, it accomplishes compliance with OSHA 1910.269: "Equipotential Zone. Temporary protective grounds SHALL be placed at such locations and arranged in such a manner as to prevent each employee from being exposed to hazardous differences in electrical potential."
- Consists of a high-ampacity tinned-copper-braid cable sewn in a grid pattern onto a vinyl/polyester fabric
- Cable terminals permit connecting the mat's grid in series with an electrical ground and the subject system component or vehicle. Simply rinsing with water comprises all the care the mat requires
- Mat may be folded and stored in a tool bag to help keep it clean and protected
- Kit includes Ground Grid, (1) P/N 692-96086 Long Ball Stud, Instructions, (1) (Chance T6002841) Ground Set, (1) Storage Bag

Basic Equi-Mat:

Part Number	Chance	Mat Size
P/N 9701-32879	C6002850	58" X 58"
P/N 9700-66912	C6002851	58" X 120"
P/N 9701-86561	C6002852	120" X 120"
P/N 9701-91223	C6002989	Kit, 58" X 58"
P/N 9000-02990	C6002990	Kit, 58" X 120"
P/N 9701-86563	C6002991	Kit, 120" X 120"

Slip-Resistant Equi-Mat:

Part Number	Chance	Mat Size
P/N 9700-98041	PSC6003345	58" X 58"
P/N 9700-98043	PSC6003346	58" X 120"
P/N 9700-98044	PSC6003347	120" X 120"
P/N 9701-86565	PSC6003348	Kit, 58" X 58"
P/N 9701-86566	PSC6003349	Kit, 58" X 120"
P/N 9701-86567	PSC6003350	Kit, 120" X 120"

Please contact 1-877-GO ALTEC (1-877-462-5832) for additional information regarding Chance products.

GROUNDING EQUIPMENT

**USA: 1-877-GO ALTEC
(1-877-462-5832)**

www.alteccconnect.com



HASTINGS

A WORLDWIDE SUPPLIER OF
Hot Line Tools & Equipment

GROUNDING EQUIPMENT

USA: 1-877-GO ALTEC
(1-877-462-5832)

www.alteconnect.com

C-HEAD GROUND CLAMPS



P/N 0692-96175
21552



P/N 8110-01042
21307



P/N 7052-01182
21070



P/N 9702-15490
11190



P/N 9000-02157
21575



P/N 9000-01037
10375



P/N 9702-59653
3172

	ALTEC	HASTINGS	DESCRIPTION	MAIN LINE RANGE MAXIMUM MINIMUM	MAXIMUM SIZE CABLE	MAXIMUM FAULT CURRENT RATING	TERMINAL TYPE	LBS
BRONZE	7052-01182	21070	SERRATED JAW	2.88 O.D. CABLE OR BUS 6 SOLID .16" DIA	4/0	43KA@ 15 CYCLES 30KA@ 30 CYCLES	THREADED	3.3
	0692-96175	21552	SERRATED JAW	500 MCM .813 DIA 8 SOLID .128 DIA				1.4
	8110-01042	21307	SERRATED JAW	1.033 MCM ACSR 1.25 DIA 6 SOLID .16 DIA				2.3
ALUMINUM	9000-02157	21575	SERRATED JAW	1.50" DIA CABLE OR BUS 6 SOLID .16 DIA	4/0	43KA@ 15 CYCLES 30KA@ 30 CYCLES	THREADED	1.5
	9000-01037	10375	SERRATED JAW	2" DIA CABLE OR BUS 4 SOLID .18 DIA				1.8
	9000-01037	10376	SAME AS 10375 BUT WITH SMOOTH UPPER JAW					1.8
	9702-15490	11190	SERRATED JAW	1,0335 MCM ACSR 1.25 DIA 8 SOLID .12 DIA			BOLTED	1.3
	9701-52331	11192	SAME AS 11190 BUT WITH SMOOTH UPPER JAW					1.3
	9702-59653	3172	SMOOTH JAW					2" DIA CABLE OR BUS 6 SOLID .16 DIA

DUCK BILL GROUND CLAMPS



P/N 9704-57183
1810-2



P/N 0100-11638
4706-4



P/N 9000-10476
10476



P/N 9703-02556
10478

	ALTEC	HASTINGS	DESCRIPTION	MAIN LINE RANGE MAXIMUM MINIMUM	MAXIMUM SIZE CABLE	MAXIMUM FAULT CURRENT RATING	TERMINAL TYPE	LBS
BRONZE	9704-57183	1810-2	SMOOTH JAWS	336.4 MCM ACSR / .75 DIA 6 SOLID / .16 DIA	2/0	27KA@15 CYCLES 20KA@30 CYCLES	BOLTED	1.1
ALUMINUM	0100-11638	4706-4	SERRATED JAWS	954 MCM ACSR / 1.15 DIA 6 SOLID / .16 DIA	4/0	43KA@15 CYCLES 30KA@30 CYCLES	BOLTED	1.5
	9000-10476	10476	SMOOTH JAWS	900 ACSR 556 MCM / 1.16 DIA 6 SOLID / .162 DIA			THREADED	1.5
	9701-56153	10477	SERRATED JAWS				THREADED	1.5
	9703-02556	10478	SMOOTH JAWS				BOLTED	1.5

TOWER AND FLAT FACE GROUND CLAMPS

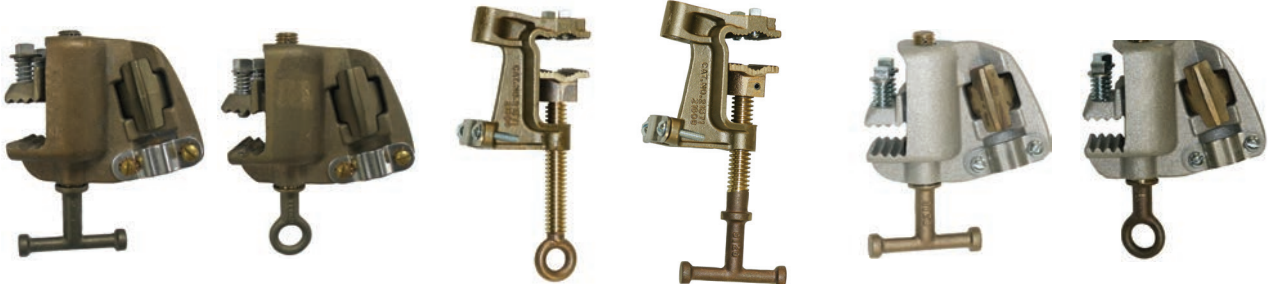

P/N 9700-46060 9123CC P/N 9704-79249 9153CC P/N 9701-80483 21571 P/N 9000-21608 21608 P/N 0020-30109 9123 P/N 9702-32872 9153

	ALTEC	HASTINGS	DESCRIPTION	MAXIMUM JAW OPENING	MAXIMUM SIZE CABLE	MAXIMUM FAULT CURRENT RATING	TERMINAL TYPE	LBS
BRONZE	9700-46060	9123CC	TEE HANDLE	1 1/2"	4/0	43KA@ 15 CYCLES 30KA@ 30 CYCLES	BOLTED	3.5
	9704-79249	9153CC	EYE SCREW					3.5
	9701-80483	21571	EYE SCREW				THREADED	2.2
	9000-21608	21608	TEE HANDLE					2.4
ALUMINUM	0020-30109	9123	TEE HANDLE	1 1/2"	4/0	30KA@ 30 CYCLES	BOLTED	1.2
	9702-32872	9153	EYE SCREW					1.2

GROUND CLAMPS FOR SUBSTATION GROUNDING

- The grounding clamps with hanger studs enable substation maintenance crews to utilize their portable grounds on large bus by providing a fault current rated hanger stud as part of the clamp (Clamp numbers 21056, 21546-1, 12282)
- Use of the hanger stud clamps could save cost of special ground assemblies made up for each substation



P/N 9706-40867 21056 P/N 9000-21546 21546-1 P/N 9702-67092 4367-2 P/N 9706-40868 4367-1 P/N 9706-40869 9071 P/N 9000-12282 12282 P/N 9700-68860 21057

	ALTEC	HASTINGS	MAIN LINE RANGE MAXIMUM / MINIMUM	MAXIMUM SIZE CABLE	MAXIMUM FAULT CURRENT RATING	TERMINAL TYPE	LBS
BRONZE	9706-40867	21056	5" O.D. 1 1/4" O.D. - STUD IS 3.25" LONG		54KA@ 15 CYCLES 39KA@ 30 CYCLES		4.5
	9000-21546	21546-1	3 5/8" X 2 1/4" RECTANGULAR BUS STUD IS 4" LONG				43KA@ 15 CYCLES
ALUMINUM	9702-67092	4367-2	4" X 1/2" FLAT BUS OR 2.875 DIA BUS 6 SOL .16 DIA	1/0	21KA@ 15 CYCLES 15KA@ 30 CYCLES	BOLTED	2.4
	9706-40868	4367-1	3" X 3" SQUARE BUS 6 SOLID .16 DIA				2.4
	9706-40869	9071	3" DIA BUS OR CABLE 6 STR .18 DIA	4/0	54KA@ 15 CYCLES 39KA@ 30 CYCLES	BOLTED	4.2
	9000-12282	12282	6.625 DIA BUS 1/0 STR .398 DIA	4/0		BOLTED	5.5
	9700-68860	21057	6.625 DIA / 9 1/2" COPPER BAR 1/0 STR .398 DIA	4/0			8.7



HASTINGS

A WORLDWIDE SUPPLIER OF
Hot Line Tools & Equipment

GROUNDING EQUIPMENT

USA: 1-877-GO ALTEC
(1-877-462-5832)

www.alteconnect.com

MULTI-PURPOSE GROUND CLAMP AND BALL STUDS

- C Head upper jaw is designed for use on conductors. Slotted "V" also allows the ground clamp to be attached to the ball stud(s) shown.
- Both sides of the clamp are drilled and tapped to attach ball studs for use as hanger studs. Drilled and tapped holes are 1/2"-13 and can also be utilized as lubrication ports.



P/N 7052-01335
21703



P/N 9706-40870
21705



P/N 9706-40871
21706

	ALTEC	HASTINGS	DESCRIPTION	MAIN LINE RANGE MAXIMUM MINIMUM	MAXIMUM FAULT CURRENT RATING	TERMINAL TYPE	LBS.	
ALUMINUM	7052-01335	21703	MULTI-PURPOSE GROUND CLAMP	556 MCM .86 DIA 6 SOLID .16 DIA	43KA@ 15 CYCLES 30KA@ 30 CYCLES	THREADED	1.1	
	9706-40870	21705	20mm BALL STUD / 1/2-13 X 1/2" LONG THREAD - TIN PLATED COPPER					0.4
	9706-40871	21706	20mm BALL STUD/ 1/2-13 X 2" LONG THREAD - TIN PLATED COPPER					0.5

BALL SOCKET GROUND CLAMPS AND BALL STUDS



P/N 9701-26170
21720



P/N 9706-40872
21726



FRONT VIEW



P/N 9706-40873
21722



P/N 8780-70912
21721



P/N 9706-40874
21725

APPLICATION
VIEW

	ALTEC	HASTINGS	DESCRIPTION	RANGE	MAXIMUM SIZE CABLE	MAXIMUM FAULT CURRENT RATING	TERMINAL TYPE	LBS
BRONZE	9701-26170	21720	EYE SCREW	1" O.D. BALL STUD	4/0	43KA@ 15 CYCLES 30KA@ 30 CYCLES	THREADED	0.9
	9706-40872	21726	T HANDLE					1.4
	8780-70912	21721	BALL STUD, 1" O.D., SHORT - 1/2-13 THREAD, 2 1/4" LONG SHANK - TIN PLATED COPPER					0.5
	9706-40873	21722	BALL STUD, 1" O.D., LONG - 1/2-13 THREAD, 4" LONG SHANK - TIN PLATED COPPER					0.8
	9706-40874	21725	BALL STUD COVER					0.2

GROUNDING CABLE FERRULES

FERRULE FOR BOLTED TYPE TERMINALS			
ALTEC	HASTINGS	SIZE AWG	LBS
9706-40875	11656	#2	0.1
9705-46065	11657	1/0	0.1
9700-46061	11658	2/0	0.1
9706-40876	11660	4/0	0.1

FERRULE FOR THREADED TYPE TERMINALS, 5/8-11 NC			
ALTEC	HASTINGS	SIZE AWG	LBS
7052-01161	12998	#2	0.3
7052-01162	12999	1/0	0.3
9700-26881	13000	2/0	0.3
9700-92396	13001	4/0	0.4
8780-70982	P50349	5" LONG HEAT SHRINK	0.1

FERRULE FOR COMPRESSION-BOLTED TYPE TERMINALS			
ALTEC	HASTINGS	SIZE AWG	LBS
9706-40877	P30244	#2	0.3
811000966	P30245	1/0	0.4
811001559	P30246	2/0	0.4
002000198	P30247	4/0	0.5

FERRULE FOR ELBOWS - URD			
ALTEC	HASTINGS	SIZE AWG	LBS
9705-27206	P30916	1/0	0.4
9706-40878	P30917	2/0	0.5

All HASTINGS ferrules are tin plated copper

- Provides added protection against corrosion



**P/N 9700-46061
11658**



**P/N 7052-01161
12998**



**P/N 8110-01559
P30246**



**P/N 9705-27206
P30916**

FERRULES WITH FACTORY APPLIED CLEAR HEAT SHRINK

- Provides positive stress relief of grounding cables at their terminations
- Clear heat shrink allows visual inspection of cable strands and termination
- Heat shrink materials provides a barrier to resist moisture and corrosion at the termination

FACTORY INSTALLED FERRULES - COMPRESSION BOLTED TYPE			
ALTEC	HASTINGS	SIZE AWG	LBS
9706-40879	6756	#2	1.0
9706-40880	6757	1/0	1.0
9706-40881	6758	2/0	1.0
9706-40882	6759	4/0	1.0



**P/N 9706-40879
6756**

FACTORY INSTALLED FERRULES - COMPRESSION 5/8-11 NC THREADED TYPE			
ALTEC	HASTINGS	SIZE AWG	LBS
9706-40883	6760	#2	1.0
7052-01292	6761	1/0	1.0
7052-01181	6762	2/0	1.0
9703-61775	6763	4/0	1.0



**P/N 9706-40883
6760**



HASTINGS

A WORLDWIDE SUPPLIER OF
Hot Line Tools & Equipment

GROUNDING EQUIPMENT

USA: 1-877-GO ALTEC
(1-877-462-5832)

www.alteconnect.com

GROUND CLUSTER BARS AND SUPPORTS

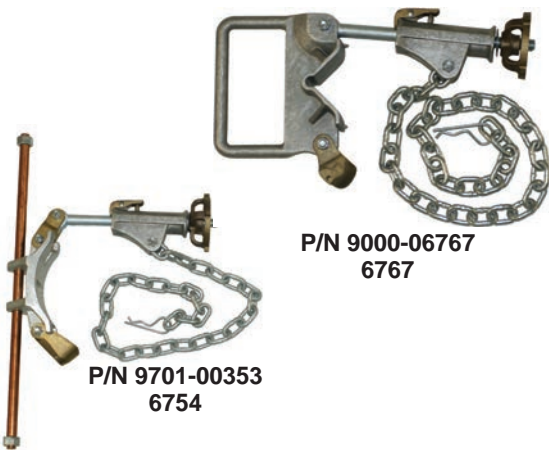

- Provides protection for operating personnel during grounding procedures and practices
- All ground clusters and supports utilize an adjustable chain tightener with 36" of chain
- Compact aluminum alloy cluster bar is 5/8" diameter. Bar accepts both "C" and duckbill type ground clamps. Tested for 43KA @ 15 Cycles.
- Aluminum base with a 5/8" diameter solid copper alloy bar. Bar accepts both "C" and duckbill type ground clamps. Copper bar will hold up to four clamps. Tested for 43KA @ 15 Cycles.

ALTEC	HASTINGS	DESCRIPTION	LBS
9000-06767	6767	COMPACT CLUSTER BAR	6.8
9701-00353	6754	ALUMINUM BASE CLUSTER BAR	8.0

4-WAY CABLE SPLICE FOR THREADED TERMINATIONS



- Used for connecting ground cables together
- Four terminal positions
- Terminals are tapped for use with 5/8-11 NC threaded grounding ferrules
- Aluminum alloy
- Splice has cable pads for stress relief of ground cables
- Tested at 43KA @ 15 Cycles

ALTEC	HASTINGS	DESCRIPTION	LBS
9000-70661	6724-1	FOUR WAY CABLE SPLICE	0.8

4-WAY CABLE SPLICE FOR BOLTED TERMINATIONS



- Used for connecting ground cables together
- Four way cable splice
- 2/0 cable maximum
- Tested at 28,900 Amps for 15 Cycles
- Bronze alloy

ALTEC	HASTINGS	DESCRIPTION	LBS
9000-50399	5755-6	GROUND CABLE SPLICE	3.0

GROUND CABLE SPLICE



- Used for connecting two ground cables together
- 4/0 cable maximum
- Aluminum alloy
- Tested at 43KA @ 15 Cycles

ALTEC	HASTINGS	DESCRIPTION	LBS
8110-01674	12423	GROUND CABLE SPLICE	1.0

MECHANICAL JUMPER CLAMPS

- Two sizes - 6 solid through 556.5 MCM; 6 solid through 954 ACSR
- Thrust bearing design provides low friction for tightening clamp
- Bronze clamping rings have serrated contact surface to insure good electrical contact with conductors
- Two styles: Yellow handles are made from bright yellow, impact resistant modified polyolefin material; Clear handles are made from a high impact plastic material
- Grip tabs are molded in for easy gripping with rubber gloves
- Conductor clamp is machined from brass alloy
- Rated for 400 amps continuous current maximum rating - this rating is dependent on the rating of the jumper cable used with the clamps



P/N 9706-40884
13004



P/N 9702-43937
11000



P/N 9000-13765
13765



P/N 9700-79323
13768

ALTEC	HASTINGS	DESCRIPTION	MAIN LINE RANGE		JUMPER CABLE RANGE		LBS.
			MAXIMUM	MINIMUM	MAXIMUM	MINIMUM	
9706-40884	13004	MEDIUM RANGE JUMPER CLAMP YELLOW	556-5 MCM OR 477 ACSR	6 SOLID .162 DIA	4/0 15KV*	#2 15KV	1.6
9000-13765	13765	MEDIUM RANGE JUMPER CLAMP CLEAR	556-5 MCM OR 477 ACSR	6 SOLID .162 DIA	4/0 15KV*	#2 15KV	1.6
9702-43937	11000	LARGE RANGE JUMPER CLAMP YELLOW	954 ACSR 36/1	6 SOLID .162 DIA	4/0 15KV 2/0 25KV 1/0 35KV	#2 15KV	2.7
9700-79323	13768	LARGE RANGE JUMPER CLAMP CLEAR	954 ACSR 36/1	6 SOLID .162 DIA	4/0 15KV 2/0 25KV 1/0 35KV	#2 15KV	2.7

*NOTE: CLAMPS WILL ACCOMMODATE 4/0 STR. 15KV CABLE ONLY IF EPR (ETHYLENE, PROPYLENE RUBBER) INSULATED CABLE IS USED.

**NOTE: IF 35KV CABLE IS REQUIRED LARGE RANGE CLAMPS MUST BE USED.

Jumper Cable Ferrules



- Tin plated copper
 - Ferrule has flat side for use with jumper head
 - 5/8-11 NC threads
- P/N 9000-50259 13102

Screw Ground Rod

- Provides a temporary ground where a system ground is not available
 - 5/8" diameter copper weld rod
 - 12" bronze handle
 - 72" overall length
 - C-head ground clamps and clusters with 5/8" 11C threaded terminals
- P/N 9000-04370 4370



MISCELLANEOUS GROUNDING EQUIPMENT

Grounds Warning Placard 16" x 18"



- Flourescent orange identification marker
- Identification marker for temporary grounds
- Features a reflective striping for night time visibility
- Secured onto the ground with Velcro®
- "Grounds" is stenciled onto the marker
- P/N 9701-34637 includes a Hot Stick Pin

P/N 9701-34637 13-526 Double-Sided
P/N 9701-64362 13-528 Single-Sided

Temporary Ground Rod



- Impact Driven or Manual Use
- Can be installed and removed with a hydraulic impact wrench
- Quick installation and removal by an impact wrench saves time and energy
- In cases where an impact can not be used, a "T" handle can be easily installed for manual installation

P/N 9703-02068 G-04



Grounding Reels with Cable

- Provide a simple, positive means for grounding line trucks or other vehicles parked in electrically hazardous areas
- Inverse loop design, silver-plated copper contact pressure under fault conditions
- Compression terminals connect the cable to the reel and ground clamp
- A removable plastic cover encases the shafts contacts to reduce contamination

Reels with Cable

P/N 0692-96072 Aeromotive with 5' of #2 GA Cable, 60' long
P/N 0692-96073 Aeromotive with 5' of #1/0 GA Cable, 60' long
P/N 0692-96074 Aeromotive with 5' of #2/0 GA Cable, 60' long
P/N 0692-96075 Aeromotive with 5' of #2 GA Cable, 40' long
P/N 0692-96076 Aeromotive with 5' of #1/0 GA Cable, 40' long
P/N 0692-96077 Aeromotive with 5' of #2/0 GA Cable, 40' long
P/N 9701-60843 Aeromotive with 5' of #4/0 GA Cable, 50' long
P/N 8110-00580 Copper U-Bolt (shown right)



Grounding Reels Without Cable

- Provide a simple, positive means for grounding line trucks or other vehicles parked in electrically hazardous areas
- Inverse loop design, silver-plated copper contact pressure under fault conditions
- Compression terminals connect the cable to the reel and ground clamp
- A removable plastic cover encases the shafts contacts to reduce contamination

Reels without Cable

P/N 0692-96069 Kearney for #2 GA Cable
P/N 0692-96070 Kearney for #1/0 GA Cable
P/N 0692-96071 Kearney for #2/0 GA Cable

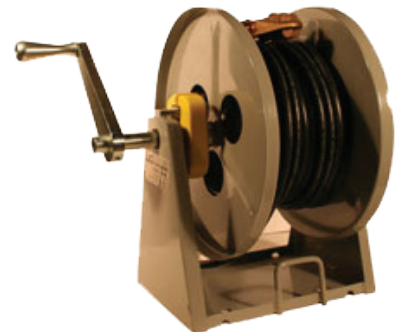

NOTE: Reels DO NOT Include Cable

DECADES OF PROVEN EXPERIENCE...

BASHLIN GROUNDING EQUIPMENT

GROUNDING EQUIPMENT

Traveling Ground

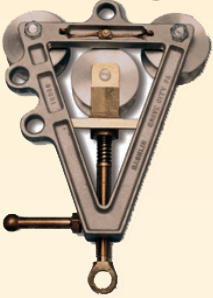

- This is a heavy duty traveling ground for conductors sized up to and including 1590 MCM
- The spring-loaded center sheave maintains tension
- The solid 1/2" aluminum rod is provided for attachment to the ground clamp

P/N 9000-99370 Bashlin 1590C

Grounding Saddle



- Light weight, aluminum
- For grounding conductors up to and including 336 MCM
- Features graphite bushings, a spring-loaded tension arm, and offset sheaves for solid contact

P/N 9000-99706 Bashlin 336A

Ground Rod Driver

- A simple, unique tool designed to ease the chore of driving ground rods
- Compact and easy to handle
- Enables a workman to drive an 8' rod while standing on the ground
- Its size and shape make it easy to store on most line trucks
- The 930 is for 5/8" ground rods, and the 930UT is also for 5/8" ground rods and features hand guards.

P/N 9705-68913 Bashlin 930

P/N 9702-30074 Bashlin 930UT



USA: 1-877-GO ALTEC
(1-877-462-5832)

www.alteconnect.com



Truck Ground

- Bashlin's 930T and 930TG truck grounds will provide suitable vehicle ground if none other is available
- A threaded 5/8" ground rod screws into the end. The driver will insert and remove the ground when the work is completed
- The 930T is the Ground Rod Driver with the threaded end, while the 930TG includes a 5' threaded ground rod.

P/N 9706-40809 Bashlin 930T

P/N 9702-74210 Bashlin 930TG

Grounding Assembly Bag

- Large open bag for longer ground sets
- Dimensions: 28"x25"
- Durable coated nylon bag
- Nylon handles are reinforced

P/N 9706-40811 Bashlin 217



TRUCK ACCESSORIES

From the name you trust and the brand you depend on, Chance Tools are optimally designed.

Auxilliary Arm Assembly

Complete Assembly

- Support arm for 3" diameter mast with solid Epoxirod® pole
- Designed for use on light construction when handling multiple conductors

P/N 720-90299 T4001857 Complete Auxiliary Assembly
Complete Assembly Includes:
P/N 720-30099 3 Roller Wireholders, No Insulator, 2.5" Opening
P/N 9000-01564 1 Arm Clamp Assembly
P/N 720-90302 1 Solid Epoxirod, 2 1/2" x 10'
P/N 720-30075 1 Adapter

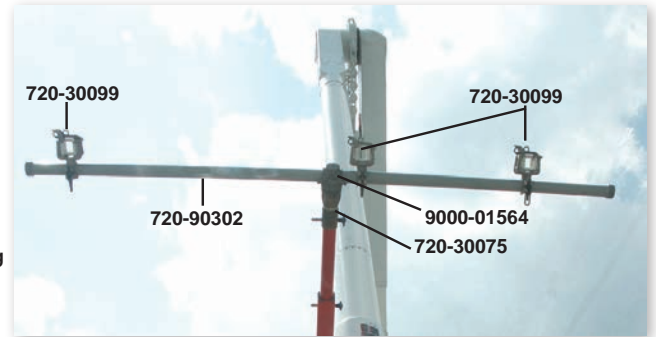

Auxilliary Arm Assembly - By Component

Roller Wireholder



- This roller wireholder offers protection to conductors while raising the the work area
 - Fits on 2" or 2 1/2" solid Epoxirod®
 - Does not feature an insulator
- P/N 720-90304 C4000268 2" opening
P/N 720-30099 C4000690 2.5" opening

Brass Arm Clamp Assembly



- Connects the adapter to the solid 2 1/2" x 10" epoxirod
- P/N 9000-01564 E4001568P

Jib Mounted Arm Attachment Round Adapter



- 3" diameter adapter
 - Used to connect the jib extension to the arm clamp assembly
- P/N 720-30075 P4001594P

Solid Epoxirod



P/N 720-90302 E4001569 (1) Solid Epoxirod, 2 1/2" x 10'

Please contact 1-877-GO ALTEC (1-877-462-5832) for additional information regarding Chance products.

TRUCK ACCESSORIES

From the name you trust and the brand you depend on, Chance Tools are optimally designed.

Common Combinations... of Jibs & Extensions with Material Handling Accessories

Jib Extension with Wireholder — 3"-diameter round Epoxiglas® Insulation

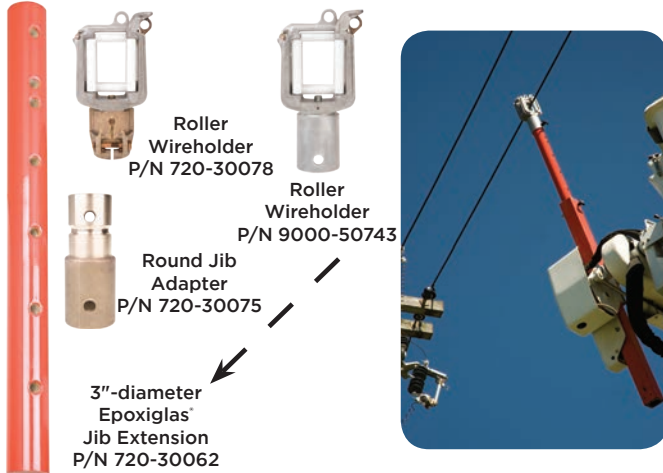

Jib Extension with Wireholder — 4" x 4" square Epoxiglas® Insulation

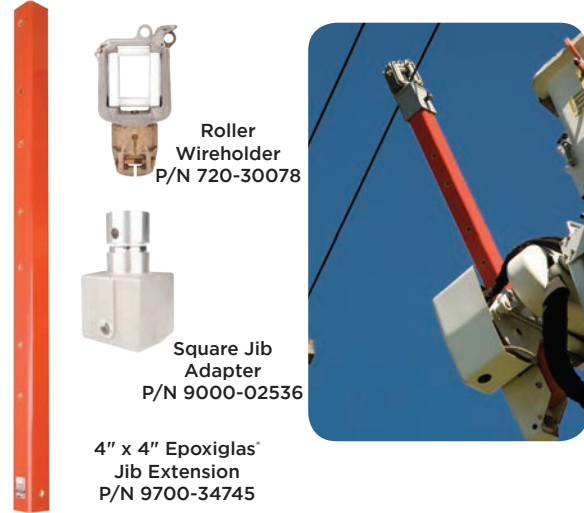

Jibs & Extensions with Material Handling Accessories

Jib Extensions & Storage Bag



- P/N 720-30116 features two adjustment holes; first hole is 2.5" from end; second hole is 40 3/8" from the first adjustment hole; 3" diameter heavy wall jib extension x 60" long
- P/N 9700-21683 3" diameter heavy wall Jib Extension is 36.7" long and features 3 adjustment holes
- P/N 720-30035 3" diameter heavy wall Jib Extension is 36.7" long and features 7 adjustment holes
- P/N 9700-34779 Altec yellow vinyl storage bag with shoulder strap is 36" long x 3.5" diameter

Part Number	Hubbell	Diameter	Adjustment Holes (Qty)
720-30116	T4002415	3"	2
9700-21683	PST4002737	3"	3
720-30035		3"	7
9700-34779	Altec Storage Bag		

Jib Extension with Wireholder



- P/N 9702-88015 features a wire holder
- P/N 9000-43059 features a wire holder on one end and a sheave (roller) on the other end
- 31" insulated rod connects both ends
- Clear coat on glass rod
- May be used in conjunction with material handler



P/N 9702-88015 PST4002818 Wireholder Only
P/N 9000-43059 PST4003059 Wireholder, Sheave

Jib Sleeve Adapter - 4" x 4"

- Fits Altec AM55 4" x 4" Jibs
- P/N 9701-90767 PST4003111



HOT LINE EQUIPMENT

USA: 1-877-GO ALTEC
(1-877-462-5832)

www.alteconnect.com

Please contact 1-877-GO ALTEC (1-877-462-5832)
for additional information regarding Chance products.

TRUCK ACCESSORIES

From the name you trust and the brand you depend on, Chance Tools are optimally designed.

Jibs & Extensions with Material Handling Accessories

HOT LINE EQUIPMENT

USA: 1-877-GO ALTEC
(1-877-462-5832)

www.alteconnect.com

Single Wireholder With Swivel



- For this holder to fit on the Altec Jib P/N 720-30035, adapter P/N 720-30075 must be used
 - Accommodates conductors up to and including 1.5" in diameter
 - Gate is held closed by a spring-loaded latch which must be manually opened
 - Features seven Delrin plastic rollers
 - 2.5" opening
- P/N 720-30078 C4000747

Wireholder/Rope Sheave Combo

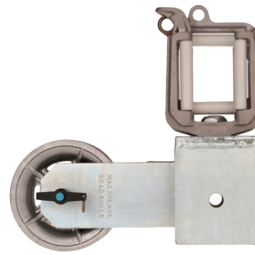

- Jib Accessory
 - "The Pickle Head"
 - Wireholder/Rope Sheave Combo
 - 800 lb. Sheave Max Capacity
 - 300 lb. Wire Holder Max Capacity
 - For use with Altec AA55E Jib Package
 - Provides an additional 3" of clearance between the bottom of the wireholder and the top of the rope sheave
- P/N 9703-58793 PST4002530005

Wireholder/Sheave Combo



For Square Jib

- 19" x 8" x 8" x 2 1/2"; 800 lb. max load
- For 4" square jib
- 2 1/2" x 3 3/8" opening
- 7" diameter sheave accepts up to 3/4" diameter rope
- Can be used in conjunction with material handler
- 7" sheave

P/N 9000-02530 T4002530
P/N 235-45009 Replacement Ball Lock Pin For Sheave
P/N 235-45018 Ball Lock Pins

Single Wireholder With Swivel



- For attachment to mast
 - Accommodates conductors up to and including 2.5" in diameter opening
 - Gate is held closed by a spring loaded latch which must be manually opened
 - For 3" diameter round jib
 - Seven Delrin plastic rollers offer protection to conductors while raising the conductor above the work area
 - 800 lb. capacity (sheave only)
- P/N 9000-50743 C4001669

Wireholder/Sheave Combo



- 2 1/2" opening
- 800 lb. max load (sheave only)
- 19" x 8" x 8" x 2 1/2"
- For 3" diameter round jib
- Can be used in conjunction with material handler
- 7" sheave

For Round Jib

P/N 9000-02529 T4002529
P/N 235-45009 Replacement Ball Lock Pin For Sheave
P/N 235-45018 Ball Lock Pins

Jib Mounted Arm Attachment Square Adapter



- Jib Adapter for Altec 4.0" x 4.0" square jibs
- For mounting arm assemblies and attachments
- Enables attachments to rotate 360°

P/N 9000-02536 P4002536P
P/N 235-45018 Ball Lock Pins

Wireholder - Without Sheave



- 2 1/2" opening
- 800 lb. max load (sheave only)
- For 4" square jib
- Can be used in conjunction with a material handler

P/N 9000-02528 PST4002856
P/N 235-45018 Ball Lock Pins

Please contact 1-877-GO ALTEC (1-877-462-5832) for additional information regarding Chance products.



ANCHORS AND ANCHOR TOOLS

From the name you trust and the brand you depend on, Chance Tools are optimally designed.

As with most mechanical devices, Chance anchor-installing tools periodically require maintenance checks to ensure peak performance. Be sure to check for worn components that need to be replaced. Please contact your Altec Supply Account Manager or call 1-877-GO ALTEC (1-877-462-5832) for additional information regarding those components.

Screw Anchor Kit - 10K System

This kit includes the specified Kelly Bar Adapter, locking dog assembly (P/N 700-00032), and 7' drive-end wrench (P/N 700-00066)

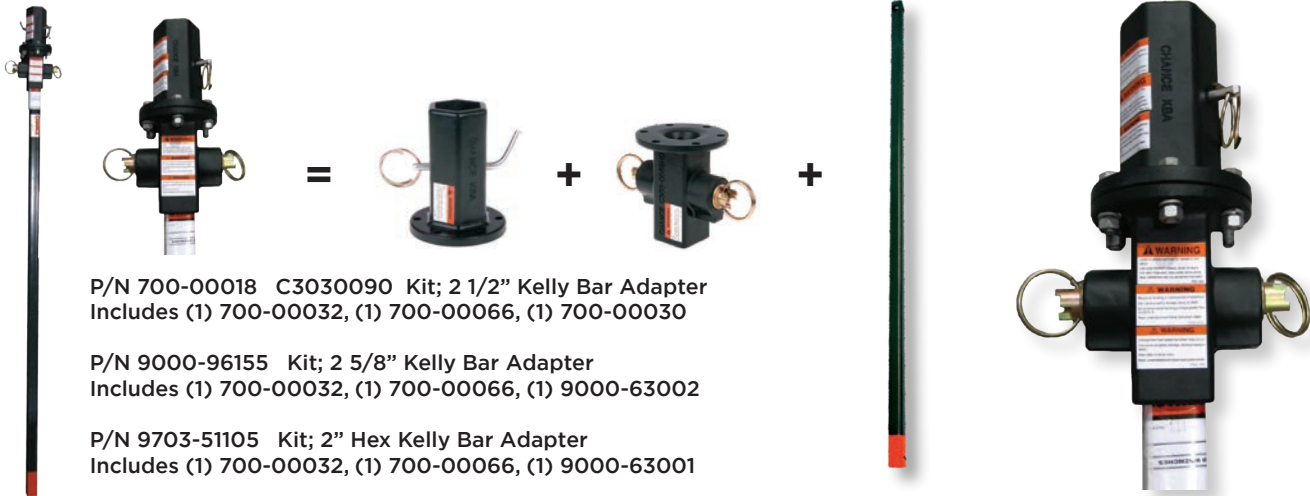

P/N 700-00018 C3030090 Kit; 2 1/2" Kelly Bar Adapter
Includes (1) 700-00032, (1) 700-00066, (1) 700-00030

P/N 9000-96155 Kit; 2 5/8" Kelly Bar Adapter
Includes (1) 700-00032, (1) 700-00066, (1) 9000-63002

P/N 9703-51105 Kit; 2" Hex Kelly Bar Adapter
Includes (1) 700-00032, (1) 700-00066, (1) 9000-63001

Screw Anchor Equipment - 10K System

Locking Dog Assemblies

10K - Locking Dog Assembly



- Features **six 1/2" diameter** holes on a 5 1/4" bolt circle
- Includes six 1/2" grade 5 bolts, nuts, and lockwashers

P/N 700-00032 C3030069HD 10K Locking Dog Assembly
P/N 9700-89872 C3030070 Repair Kit (10K Assembly)

Adapters

10K - Kelly Bar Adapter with Bent Arm Pin



- Six 1/2" diameter holes on a 5 1/4" bolt circle
- Includes six 1/2" bolts, nuts, lock washers, and a bent arm pin with a coil lock

P/N 9000-99360	630017	Square, 2 1/2"
P/N 700-00030	630011HD	Hex, 2 1/2"
P/N 9000-63001	630013	Hex, 2"
P/N 9000-63002	630012HD	Hex, 2 5/8"

Please contact 1-877-GO ALTEC (1-877-462-5832) for additional information regarding Chance products.

HOT LINE EQUIPMENT

USA: 1-877-GO ALTEC
(1-877-462-5832)

www.alteccconnect.com

ANCHORS AND ANCHOR TOOLS

Anchor Wrenches

10K - 1 1/2" Core Anchor Hybrid Drive-End Wrenches

- Installs PISA® 6,000 & 7,000 and 8,000 ft.-lb. (large hub) Tough One® Anchors

P/N 7054-00108	C3031063	3.5'
P/N 8960-21700*	C3031064	7'

10K - 1 3/8" Standard Core Anchor Drive-End Wrenches

- Fits 1 3/8" core anchors
- Installs 8,000 ft. lb. (small hub) Tough One® Anchors, 10,000 ft. lb. (small hub) Tough One® Anchors, standard strength and mid-strength anchors

P/N 700-00034*	C1021595	3.5'
P/N 700-00066*	C1021583	7'

Screw Anchor Equipment - 15K System

Locking Dog Assemblies

TOUGH ONE® 15K -Locking Dog Assembly



- Features **twelve 5/8" holes** on a 7 5/8" bolt circle
- Includes twelve 5/8" grade 2 bolts, nuts, and lockwashers
- P/N 9000-99720** includes all parts in **P/N 700-00053** less casting

P/N 700-00053	C3030981	Locking Dog Assembly
P/N 9000-99720	C3031026	Repair Kit

Adapters

TOUGH ONE® 15K - Kelly Bar Adapter With Bent Arm Pin



- Features **twelve 5/8" holes** on a 7 5/8" bolt circle
- Includes 5/8" bolts, nuts, lock washers, and a bent arm pin with a coil lock

P/N 700-00051	C3030936	Hex, 2 1/2"
P/N 700-00052	C3030937	Hex, 2 5/8"
P/N 9703-51294	C3031571	Square, 3 1/2"

Anchor Wrenches

TOUGH ONE® 15K - 1 1/2" Core Anchor Drive-End Wrenches

- Fits Tough One® Anchors, 1 1/2" core anchors
- Installs Tough One® Anchors, 8,000 ft. lb. and 15,000 ft. lb. (large hub)

P/N 9000-30982	C3030982	3.5'
P/N 700-00054	C3030983	7'

Screw Anchor Kit - 15K System

This kit includes the specified kelly bar adapter, locking dog assembly (P/N 700-00032), and 7' drive-end wrench (P/N 700-00066)

P/N 9703-51525 Kit; 2 1/2" Kelly Bar Adapter
Includes (1) 700-00053, (1) 700-00054, (1) 700-00051

P/N 9703-51528 Kit; 2 5/8" Kelly Bar Adapter
Includes (1) 700-00053, (1) 700-00054, (1) 700-00052

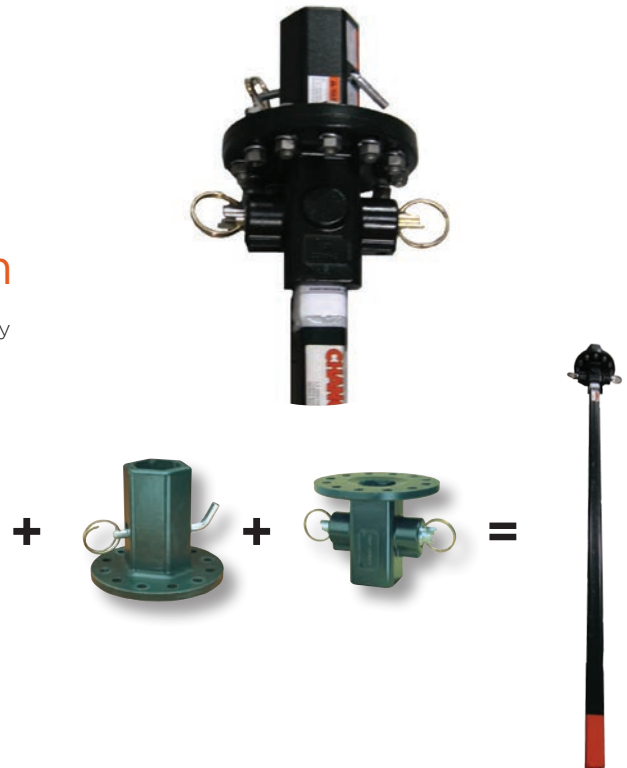

Please contact 1-877-GO ALTEC (1-877-462-5832) for additional information regarding Chance products.

ANCHOR TOOLS

HOT LINE EQUIPMENT

USA: 1-877-GO ALTEC
(1-877-462-5832)

www.alteccconnect.com

Anchor Drive End Extension - 10K

- Extends core anchor drive-end wrenches an additional 3.5' or 7.0'
- 10,000 ft. lb. torque rating

P/N 9000-50744 630027 3.5' 42 lb.
P/N 9000-50745 630028 7.0' 71 lb.



TOUGH ONE® Anchor Drive End Extension - 15K

- Extends Core Anchor Drive End Wrenches an additional 3.5' or 7.0'
- 15,000 ft. lb. torque rating

P/N 9000-50747 C3030987 3.5' 50 lb.
P/N 9000-50748 C3030988 7.0' 87 lb.



Bolt Circle Adapter



- Used to connect two tools with incompatible bolt circles
- P/N 9000-30115 is for use between two tools having tapped 5 1/4" bolt circles
- P/N 9000-30166 is for use between a tool having a 5 1/4" bolt circle and one having a 7 5/8" bolt circle
- Both are limited to 10,000 ft. lb.

P/N 9000-30115 C3030115
P/N 9000-30166 T3030166

Adapter for Installation of SS or RR Anchors



- Slides into the P/N 7163-00001 (Chance C3030069HD) locking dog adapter and is retained by a spring loaded dog
- Weighs approximately 8 lb.

P/N 9000-30020 C3030020

Expanding & Tamping Bar



- Fiberglass handle
- Simplifies the job of expanding anchors
- The curved Expander and Tamping Head distributes the weight of the bar evenly around the anchor rod to reduce handle vibration
- The hook of the Expanding and Tamping Bar wraps around the anchor rod to keep the expanding head from slipping off the anchor top plate
- This tool is also effectively used for

tamping in soil above the installed anchor

- Base casting is attached directly to the fiberglass handle

P/N 9000-99863 C3020004 12' 24 lb.

Anchor Installing Tool Pin



- Plated-steel bent arm pins
- Designed to attach a Kelly bar adapter to a Kelly bar
- Used to secure SS, RR, and bumper post anchors to anchor drive tools
- Bent arm pins are included with new tools as required

P/N 9000-31223 C3031223 4 1/2" x 1/2"
Fits P/N 700-00030, 9000-63002, 9000-63001 Kelly Bar Adapter
P/N 9000-31227 C3031227 5" x 3/4"
Pin fits P/N 9000-99360 Kelly Bar Adapter
P/N 9000-31226 C3031226 3" x 5/8"
Pin fits P/N 9000-30020 fits SS/RR tool
P/N 9000-99684 C3031222 5" x 5/8" Coil Lock Assembly
P/N 9000-99683 P3031215P Coil Keeper

Light Pole Anchor Plate



P/N 9000-30139



P/N 7054-00607

- Plates fit STL foundation anchors with 9" to 13 1/2" bolt circles
- P/N 9000-30139 connects directly to a Kelly bar adapter with (6) 1/2" furnished bolts and features a torque rating of 10,000 ft. lb.
- P/N 7054-00607 includes (12) 5/8" bolts and features a torque rating of 20,000 ft. lb.
- Coupling P/N 7054-00607 to a Kelly bar adapter with a 5 1/4" bolt circle requires use of P/N 9000-30166 adapter and limits tool's maximum torque rating to 10,000 ft. lb.

Part Number	Chance	Bolt Circles, Holes
9000-30139	C3030139	5 1/4", (6) 1/2" Tapped Holes
7054-00607	C3030684	7 5/8", (6) 5/8" Drilled Holes

Foundation Anchor Installing Tool



- Used for installing flange-drive foundations
- The drive tool has six 1/2"-13 tapped holes on a 5 1/4" bolt circle and requires a Kelly Bar Adapter (sold separately)

P/N 9000-13010 C1300010

Please contact 1-877-GO ALTEC (1-877-462-5832) for additional information regarding Chance products.

ANCHOR TOOLS

How to Match Anchors and Installing Wrenches

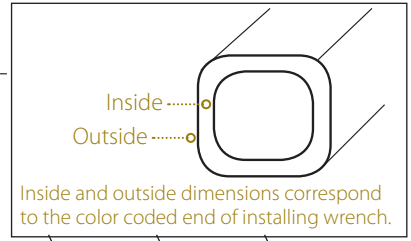

Anchor Type	Altec Part Number	Installing Wrench Catalog Number	Length ft	Maximum Installing Torque Rating ft-lb	Outside Dimension Inches	Inside Dimension Inches		
PISA® 6 Anchor (formerly PISA® 5 Anchor)	0700-00066	C102-1583 ⁽¹⁾	7	10,000	2.16	1.46		
PISA® 7 Anchor	0700-00034	C102-1595 ⁽¹⁾	3½	10,000	2.16	1.46		
Standard-Strength PISA® Anchor	8960-21700	C303-1064 ⁽¹⁾	7	10,000	Top 2.16 Bot. 2.44	Top 1.46 Bot. 1.54		
Mid-Strength PISA® Anchor	7054-00108	C303-1063 ⁽¹⁾	3½	10,000	Top 2.16 Bot. 2.44	Top 1.46 Bot. 1.54		
Tough One Anchor - Small Hub	0700-00054	C303-0983 ⁽²⁾	7	15,000	2.44	1.54		
Tough One Anchor - Small Hub C102-52XX Series	9000-30982	C303-0982 ⁽²⁾	3½	15,000	2.44	1.54		
Tough One Anchor - Large Hub C102-50XX Series								
Tough One Anchor - Large Hub C102-52XX Series								
Maximum Installation Torque Rating ft-lb	6,000	7,000	4,000	6,000	8,000	10,000	10,000	15,000

- (1) Fits Locking Dog Assembly P/N 0700-00032 (C303-0069HD).
- (2) Fits Locking Dog Assembly P/N 0700-00053 (C303-0981).

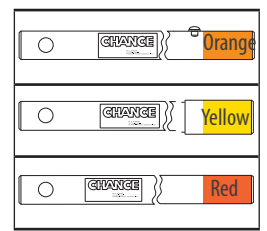

Torque Indicators

Digital Torque Indicator



- Install screw anchors to a pre-determined torque value
- Accuracy: ±500 ft.-lb. at any reading
- Torque is measured via strain gauges
- Powered by a standard 9V battery
- No Shear pins to replace
- Mounts between Kelly bar adapter and drive tool or locking dog assembly
- LED display gives a direct readout
- Helps avoid excessive torsional loading which could cause damage

to the anchor and/or other anchor tools during installation

- Solid one-piece spool, designed to withstand bending loads
- Operational temperature range: -40° to 80°C (-40° to 175° F)
- Top and bottom flange - each provides: Six holes tapped 12"-13 on a 5¼" bolt circle and twelve holes tapped 58"-11 on a 7 5/8" bolt circle

P/N 9000-31340 C3031578

Shear Pin Torque Indicator



- Designed for installing torques up to 10,000 ft. lb.
- Offers protection for anchors and installing tools by disconnecting the power source from drive tools
- Durable; does not require special storage/handling
- Useable in very rocky soil
- Includes six 1/2" - 13 tapped holes on a 5 1/4" bolt circle, both ends

P/N 9000-30044** C3030044

**Kelly Bar Adapter and Locking Dog Assembly are not included

Pins for Shear Torque Indicator:

P/N 9000-30045 C3030045 Carton of approximately 1,700 pins

P/N 9000-99674 T3031420 Box of approximately 510 pins

Wireless Torque Indicator



- Operational temperature range: -30° to 80°C (-22° to 175° F)
- Accuracy: ±500ft.-lb at any reading
- Torque is measured using strain gauges
- No shear pins to replace
- Powered by a standard 9V battery
- Base unit with wireless display
- Torque is displayed on Base Unit and on Wireless Display
- Multiple Wireless Display units can be linked to Base Unit
- Solid one-piece spool design to withstand bending loads

- Top and bottom flange, each provides six holes tapped 12"- 13 on a 5-14" bolt circle and twelve holes tapped 58"- 11 on a 7-58" bolt circle

Data Logger

- Torque displayed on Data Logger
- Torque and GPS data recorded and saved on Data Logger
- Data downloadable from Data Logger to computer spreadsheet

P/N 9706-37127 C3031689

P/N 9706-37128 C3031690

P/N 9706-37129 C3031723

P/N 9706-37130 C3031724

Base Indicator with Wireless Display Screen
Wireless Torque Data Logger
Wireless Display Screen
Indicator Kit (Base Indicator with Wireless Display Screen and Data Logger)

CONDUCTOR SUPPORT EQUIPMENT

HOT LINE EQUIPMENT

Epoxiglas® Extension Arm



P/N 9000-48060 H480060 5' long 1 Wireholder
P/N 9000-48072 H480072 6' long 2 Wireholders

- Designed for use on voltages up to and including 15kV where reconductoring or insulator replacement is necessary
- Epoxiglas® Extension Arm can be used on voltages up to 34.5 kV providing the wireholders are fitted with P/N 9000-48057 insulators
- Maximum crossarm size: 3 3/4" x 4 3/4"
- Arm diameter: 2 1/2"
- Maximum vertical loading per wireholder: 150 lb.

Chain Type Temporary Conductor Supports



P/N 9000-48091



P/N 9000-41509

- Used to hold energized distribution conductors during replacement of poles or repair or replacement of pole top and stand-off insulators
- Furnished with wheel tightener for poles up to 14" in diameter
- Working load is 150 lb. per wireholder

P/N 9000-48091 H4809W Single Conductor Support
P/N 9000-41509 C4001509 Two Conductor Supports

35kV Tension Puller Switching Tool



- Combines line tension disconnect switch with Epoxiglas® insulated tool
- Weathershed polymer skirts are bonded to 1.5" diameter pole
- Compression clamps secure switch hot parts to pole
- 1/2" Bypass stud at each end accepts 3" wide jumper clamps
- Copper switch blade with silver-plated contacts opens to 90°, or 180° with stop pin removed
- Galvanized hooks provided for operation by loadbreak device
- With handling rings, this tool may be operated by either hot line tools or rubber glove techniques

P/N 9000-40019 C4001907

Nylon Strap Type Temporary Conductor Supports



- D-shaped buckle on the strap free end adds speed and convenience
- Polyester strap offers less stretch
- With 10,000 lb. rated tensile strength, 2" wide strap comes in 44" length to fit most structures
- Wide handle opening on rapid-action ratchet permits easy operation

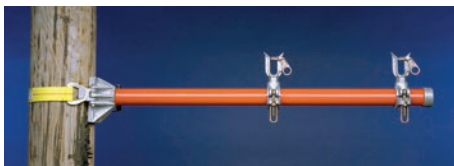

P/N 9000-01939 T4001939 Double Conductor Support (top)
P/N 9000-01940 T4001940 Single Conductor Support (bottom)

USA: 1-877-GO ALTEC
(1-877-462-5832)

www.alteconnect.com

Please contact 1-877-GO ALTEC (1-877-462-5832)
for additional information regarding Chance products.

CONDUCTOR SUPPORT EQUIPMENT

Universal Extension Arms



P/N 9703-93307 PSC4004101



Rubber grippers removed for use on wood crossarms

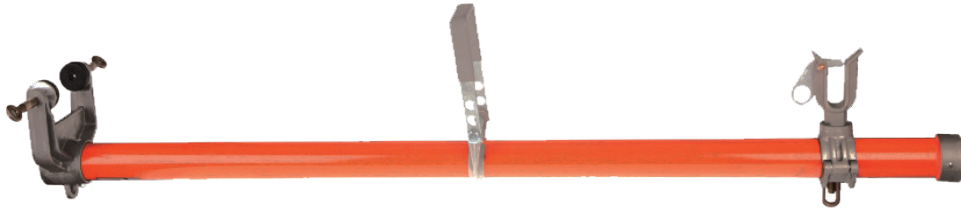

P/N 9703-93314 PSC4004102

- Fit composite or wood crossarms up to 3-3/4" x 4-3/4"
- Cushioned clamp and hanger loop to protect composite arms
- Grippers on clamp can be removed for wood crossarms
- Design allows removal of components for reconditioning pole
- Designed for use with rubber gloves or hot sticks

P/N 9703-93307 PSC4004101 6' Universal Extension Arm
P/N 9703-93314 PSC4004102 5' Universal Extension Arm

Universal Extension Arm Retrofit Kit

Allows conversion of wood-only Extension Arms to Universal Extension Arms

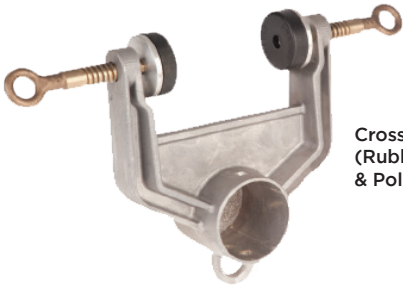

Crossarm Clamp (Rubber Grippers) & Pole End Fitting



Carriage Bolt & Nut



Crossarm Loop (Plastisol Coated) & Pole Clamp



Kit Instructions show how to cut off the old end fitting and drill for the attachment of the new end fitting via a carriage bolt.

Conversion permits easy removal of the Crossarm Clamp for periodic reconditioning of the pole.

P/N 9703-93319 PSC4004103
6' Universal Extension Arm Retrofit Kit

Please contact 1-877-GO ALTEC (1-877-462-5832) for additional information regarding Chance products.

CONDUCTOR SUPPORT EQUIPMENT

Temporary Cutout Tools

- Provides fuse protection during live-line maintenance
- Insulated bushing and hot parts are from Chance Type C-Polymer cutouts
- Upper contact with integral sleet shield and hooks are made of cast bronze
- Fusetube must be fitted with fuselink rated no larger than 100 amps

Standard Type Fuse Tubes:

(100 Amps of Continuous Current)

P/N 9701-06652 PSC6010341 15kV 10,000 Amps Interrupt Cap.

P/N 9701-06653 PSC6010342 27kV 8,000 Amps Interrupt Cap.

Standard Type Solid Blade Type Fuse Tubes:

(300 Amps Continuous Current)

P/N 9701-06655 PSC6010343 15kV; 12,000 Amps Momentary Cap.

P/N 9701-06657 PSC6010344 27kV; 12,000 Amps Momentary Cap.

Pivot Lever Type Closing Device

P/N 9701-06660 PSC6010345 15KV

P/N 9701-06663 PSC6010346 27KV

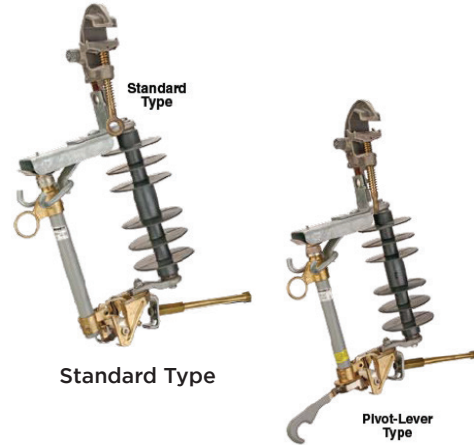

Standard Type

Pivot-Lever Type

Pivot Lever Type

34.5 kV Hot Stick Tension Puller



- Equipped with rings for operation with the Grip-All Clampstick or with rubber gloves
- Non-swiveling hook on each end for positive hot stick operation
- Spring-loaded gate will rotate 135° left or right from closed position
- Selector lever on the ratchet wrench accommodates hot sticks

P/N 9700-87378 C4000574

Corner Restraint Bracket Tool

- Corner restraint bracket tool helps control each phase conductor while insulators are changed
- Acts as a load restraint for the hoist to pull the conductor back in for reconnection to the insulator string
- 2,000 lb. maximum load rating
- 2 1/2" diameter, 6" clear length



P/N 9000-42272 T4002272

Lever Lift Arbor Tool Wire Tong Support

- Allows conversion of the single type lever lift to a double type when desired



P/N 9700-53729 M47602 Lever Lift Arbor Tool

Temporary Load Disconnect Tools



- Provides a temporary means of connecting and disconnecting equipment or circuits under load conditions
- Does not have a fuse and does not provide protection for fault or overcurrent conditions
- Insulated bushings and hot parts are from Chance Type C-Polymer cutouts, including the tubular copper disconnect blade
- An arc-chute type interrupter gives the tool its excellent loadbreak capability
- Tool clamps onto primary conductor with a Grip-All clampstick

P/N 9701-06667 PSC6010347 8.3/15KV

P/N 9701-06668 PSC6010348 15/27KV

Crossarm Wire Tong Saddle

- Used on underbuilt arms when working space is limited or crowded with pole saddle(s)
- The pivoting action of the saddle swivel and pole clamp attachment provides a universal-joint action which allows complete freedom of movement of the wire tong in any direction and without binding
- Saddle does not include pole clamps
- Maximum work load is 500 lb.



P/N 9700-53369 M4744 Crossarm Wire Tong Saddle

HOT LINE EQUIPMENT

USA: 1-877-GO ALTEC
(1-877-462-5832)

www.alteconnect.com

Please contact 1-877-GO ALTEC (1-877-462-5832) for additional information regarding Chance products.

CONDUCTOR SUPPORT EQUIPMENT



P/N 9700-88002



P/N 9700-53367
P/N 9700-53368

Pole Wire Tong Saddle & Clamps

- Made of lightweight aluminum
- Will support a maximum of 1,000 lb. without the extension
- Clamp is set far enough away from the base to give ample clearance for most jobs
- Where additional clearance is required, the Chance Wire Tong Saddle Extension can be easily bolted to the saddle
- Heat treated aluminum-alloy extension is 4" long and has a tested working load rating of 800 lb.
- Wheel Type fasteners are easy to apply, hold the saddle firmly in place, and prevent riding down and excessive play
- Wheel Tightener has the advantage of being able to fit into close places such as between crossarm braces, under guy wires, etc.

P/N 9700-88002 M4740-3W Pole Wire Tong Saddle
P/N 9700-53367 M4741-3 Pole Clamp Only 2.5" Dia. Opening
P/N 9700-53368 M4741-2 Pole Clamp Only 2" Dia. Opening

12' Wire Tong



- Made with Epoxiglas® poles
- Castings are made of heat treated aluminum alloy, separated by bronze wear rings
- Wide range jaws on the head can be clamped tightly on the conductor by turning the stick from a 8 position beyond the minimum working clearances
- Designed for use in many applications: moving and holding live conductors clear of the working area, flat crossarm and/or ridge pin-construction, on horizontal post insulator structures, with all types of suspension insulator lines, for use as auxiliary arm braces, and in EHV construction for brace pole or ladder positioning guides

P/N 9700-53356 H464612 Wire Size .16" - 2.25"



Wire Tong Tower Saddle w/Regular Hooks

- Used to support wire tongs or boom poles on towers
- Saddle is securely fastened to the angle iron tower leg by four hooks tightened by wing nuts
- A clevis which bolts through the pivot lug permits rope blocks to be fastened so that they will pivot with the wire tong or boom pole
- Saddle does not include pole clamps
- Fits angles 3" x 3" to 7" x 7"

P/N 9700-53370 M4742 Wire Tong Saddle w/Regular Hooks

35kV Epoxy Insulator



- Epoxy based
- Can be added to existing auxiliary arm wireholders to upgrade for 34.5 kV use

P/N 9000-48057 M48057

Rope Snubbing Bracket



- Provides an easy way to prevent line snarls by snubbing all hand or light block lines to this bracket, mounted at the base of the pole to the six different rings
- Bracket has a maximum total working load of 1,000 lb.

P/N 9700-53372 M1846W

18" Extender Chain



- Increases length of the chain tightener so it may be used on large diameter poles

P/N 9700-53371 M1847

Please contact 1-877-GO ALTEC (1-877-462-5832) for additional information regarding Chance products.

Chain Binder Type Transformer Gin



P/N 9000-40090 Standard Base **P/N 9000-40315 Extended Base**

- Versatile tool for hoisting distribution transformers and apparatus up the structure
- Standard base unit is for mounting on clear pole sections; 5" extended base model allows mounting to bridge up to 4" x 5" crossarms
- Gins are not intended for applications involving

- side pull on the hoist line, or with the lift load in a tagged out position
- Includes wheel tightener and 36" chain
- 2,000 lb. maximum rating, including hand pull force
- Pole length: 26"

P/N 9000-40090 C4000090 Standard Base
P/N 9000-40315 C4000315 Extended Base

56" Crossarm Gin



- Yoke casting fits over distribution crossarms, so this crossarm gin can be used with rope blocks or handline to lift conductors from their insulators
- Removable cadmium-plated steel pin allows crossarm adjustment - 3.5" x 4.5" to 4.75" x 5.75"
- At a 30° maximum angle from vertical, 56" gin has rated working load including pull force of 500 lb.
- Gins are not intended for applications involving side pull on either hoist line or load lines;

therefore, load line must be parallel to the gin pole; lines must be within 5° of vertical

P/N 9700-53556 T4000870

Strap Type Binder Transformer Gin

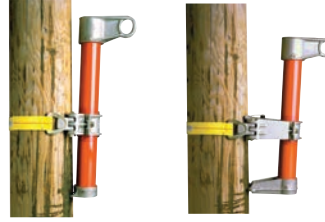

P/N 9000-41937 Standard Base **P/N 9000-41938 Extended Base**

- Similar to the chain binder type transformer gin, but with a strap-type ratchet-action mounting mechanism
- 2" wide polyester strap features a 44" length to fit most structures
- Strap has a 10,000 lb. rated tensile strength
- Wide handle opening on rapid-action ratchet

- permits easy operation, even with rubber gloves and leather protectors
- Wheel tightener and 36" chain is a part of each unit
- 2,000 lb. maximum rating, including load and fall-line pull
- Pole length: 26"; pole diameter: 3"

P/N 9000-41937 T4001937 Standard Base
P/N 9000-41938 T4001938 Extended Base

Swivel Top Gin



- Same application as the transformer gin, but the top eye casting can be swiveled to bypass secondary lines when necessary
- Cap is not intended to swivel while under load
- Includes wheel tightener and 36" chain
- 2,000 lb. maximum rating, including hand pull force
- Pole Length: 48"

P/N 9000-40400 C4000440

Clampsticks & Accessories

Chance Grip-All Single Piece Style Hot Stick (Shotgun Stick)



- Chance Grip-All stick puts an easy-to-control "finger" on an insulated pole
- Serves both overhead and underground circuits with various end fittings
- Commonly called a "shotgun," the operating mechanism incorporates a sliding hand grip that opens the hook to grasp a clamp eyescrew and retract it into the tool head; a thumb latch then must be depressed to release the locked hand grip so it can open the hook
- Easy to care for, Grip-All sticks do not require field stripping to clean; all insulated parts including the operating rod are outside the main pole, readily accessible to wipe dry

CAUTION: Do not clean the plastic head with solvent

Part Number	Chance	Description
0704-20132	C4030291	1 1/4" x 4' 5"
9000-40302	C4030292	1 1/4" x 6' 5 1/2"
9000-30293	C4030293	1 1/4" x 8' 5 1/2"
9000-30294	C4030294	1 1/4" x 10' 5 1/2"
9000-30295	C4030295	1 1/4" x 12' 5 1/2"

Please contact 1-877-GO ALTEC (1-877-462-5832) for additional information regarding Chance products.

CLAMPSTICKS & ACCESSORIES

Chance Grip-All Single Piece Style Hot Stick (Shotgun Stick)

- Chance Grip-All stick puts an easy-to-control “finger” on an insulated pole
- Serves both overhead and underground circuits with various end fittings
- Commonly called a “shotgun,” the operating mechanism incorporates a sliding hand grip that opens the hook to grasp a clamp eyescrew and retract it into the tool head; a thumb latch then must be depressed to release the locked hand grip so it can open the hook
- Easy to care for, Grip-All sticks do not require field stripping to clean; all insulated parts including the operating rod are outside the main pole, readily accessible to wipe dry

CAUTION: Do not clean the plastic head with solvent

Chance Grip-All Hinged Style Hot Stick

- Ideal for troubleshooters with limited tool-storage space in their vehicle, this folding version operates with the same features as the one-piece style

Part Number	Chance	Folded	Extended
9000-30296	C4030296	3' 4"	1/4" x 6' 7"
9000-30297	C4030297	4' 4"	1 1/4" x 8' 6"
9000-30298	C4030298	5' 4"	1 1/4" x 10' 6"
9000-30299	C4030299	6' 4"	1 1/4" x 12' 6"
9000-30342	C4030342	7' 4"	1 1/4" x 14' 6"
9000-30343	C4030343	8' 4"	1 1/4" x 16' 6"



Part Number	Chance	Description
0704-20132	C4030291	1 1/4" x 4' 5"
9000-40302	C4030292	1 1/4" x 6' 5 1/2"
9000-30293	C4030293	1 1/4" x 8' 5 1/2"
9000-30294	C4030294	1 1/4" x 10' 5 1/2"
9000-30295	C4030295	1 1/4" x 12' 5 1/2"



Photo on Left:
P/N 9000-01868 M1867

To convert any Grip-All stick to use all Universal Tool Accessories, adapter (P/N 9000-01868) secures in the clampstick hook and head housing.



SafetyShield Hot Stick Barriers



- Mounts on a 1 1/4" or 1 1/2" diameter live-line tool
- Creates a 16", 21", or 24" diameter protective screen between a lineman and a potential electrical hazard
- Fits on clampsticks, hooksticks, elbow-puller tools
- Two flame-retardant transparent polycarbonate protective shields affixed with a nylon fastener to a nylon 33% glass-filled clamp
- Orange protective storage case included

P/N 9701-94512	PSC4170627	16" Gripall
P/N 9700-87419	PSC4170628	21" Gripall
P/N 9701-55196	PSC4170629	24" Gripall

Meter Claw™ & Safetyshield™ Barrier



- Transparent polycarbonate 24" diameter barrier for full view and protection
- Ergonomic handles for stable control, leverage and minimal fatigue, help prevent injuries from repeated pulls/installs
- Fit single and multi-phase meters (residential and commercial)
- Non-conductive jaws grasp back of meter base not just bezel

Part Number	Chance	Description
9704-90581	PSC4170638	Meter Claw™ & Safetyshield™ Barrier with Bag
9704-90593	PSC4170639B	Meter Claw™ with Bag PSC4170644
9704-90596	PSC4170639	Meter Claw™ only
9704-90601	PSC4170640	Meter Safetyshield™ Barrier with Bag

Grip-All Clampstick Assist Ring



- Provides a suspension midpoint for any Grip-All stick
- Particularly helpful on longer sticks, the assembly permits a support line to attach at the smaller ring
- To help maintain safe working

clearances for hot line procedures, an insulated Strain Link Stick of proper size should be used in the handline

P/N 9000-32543 3 1/2 lb./1.6 kg.

Positive Grip Epoxiglas® Clampstick



- Made for use on eyescrew grounding on tap clamps
- Can be mounted on the line and tightened at angles up to 30°
- Fittings are aluminum and bronze
- The butt end of the tool is equipped with a combination tool hanger and universal head
- Extra long head for use with long eyescrew ground clamps

Part Number	Chance	Head Type	Dimensions
9000-30302	HG30302	Regular	1 1/4" x 8' 6"
9000-21303	HG303012	Extra Long	1 1/4" x 8' 6"

Heads Only:			
9000-30422	HG30422	Regular Head Only	
9000-30425	HG30425	Extra Long Head Only	

Please contact 1-877-GO ALTEC (1-877-462-5832) for additional information regarding Chance products.

CLAMPSTICKS & ACCESSORIES

HOT LINE EQUIPMENT



6' Ratchet Wirecutters

- High-performance design incorporates Delrin plastic rollers and a two-piece operating rod
- Roller mechanism travels smoothly along main Epoxiglas® pole
- Meet OSHA Electrical Rating subpart section 1926.951 (d).
- Insulated support pole is Chance orange 1 1/2" diameter Epoxiglas with Plastisol butt cap
- Operating shaft is 3/8"-diameter solid fiberglass rod; lever handle is 1"-diameter Epoxiglas with rubber cushion grip

P/N 9701-55198 C4031381 6' Soft Wire
P/N 9000-31382 C4031382 6' ACSR



Epoxiglas® Wireholding Stick

- Used on or around energized lines for forming, bending and positioning jumper wires and for holding conductors during splicing operations
- The gripper, with an eye that allows other sticks to assist with heavy bending, accommodates #6 solid copper through 1590 kcmil ACSR
- The head of the tool locks in three stop positions so that the lineman can engage and position conductors easily from most angles
- The knurled screw handle below the jaw opening is used to adjust the head position from straight to right or left

Part Number	Chance	Dimensions
9000-30368	C4033068	1 1/4" x 6' 5"
9000-30369	C4033069	1 1/4" x 8' 5"



Ratchet 8' Wirecutter

- High-performance design incorporates Delrin plastic rollers and a two-piece operating rod
- Roller mechanism travels smoothly along main Epoxiglas® pole
- Linked through the roller support unit, the hinged operating rod and larger Epoxiglas® pole reinforce each other
- Meet OSHA Electrical rating subpart V-section 1926.951 (d)
- Insulated support pole is Chance orange 1 1/2" diameter Epoxiglas® with Plastisol butt cap, operating shaft is 3/8" diameter solid fiberglass rod
- Lever handle is 1" diameter Epoxiglas® with rubber cushion grip

P/N 9700-53517 C4031384



SafetyShield Wirecutter Hot Stick Barrier



- Two flame-retardant transparent polycarbonate protective shields affixed with a nylon fastener to a nylon 33% glass-filled clamp
- Mounts on a 1 1/2" diameter ratchet wire-cutter handle in less than a minute
- Creates a 16" diameter protective screen between a lineman and a potential electrical hazard
- Orange protective storage case included

P/N 9701-55197 fits strictly on Ratchet Wire Cutters
P/N 9701-55198 (C4031381), P/N 9000-31382 (C4031382),
P/N 9701-33022 (C4031383), and P/N 9701-57181 (C4031384)

P/N 9701-55197 PSC4170630 16" Cutter

USA: 1-877-GO ALTEC
(1-877-462-5832)

www.alteconnect.com

Please contact 1-877-GO ALTEC (1-877-462-5832)
for additional information regarding Chance products.

TELESCOPING HOT STICKS

Telescoping Measuring & Disconnect Stick - METRIC & ENGLISH



- Certified to OSHA dielectric requirements (Sub-part V, section 1926.951)
- Measures pole heights and conductor clearances from the ground
- Universal end fitting on the insulated top section accepts a wide variety of attachments so that the lineman can disconnect switches, replace cutout tubes and reclose, remove pole covers, prune trees, etc., with one tool
- Measuring scales are easy-to-read, with figures silk screened on orange fiberglass sections
- English scales are marked with each 1' increment designated in a box, each inch in bold numbers and half inches designated by intermediate bars
- Metric scales similarly display meters, decimeters and centimeters
- A positive spring-loaded locking-button mechanism and safety plug feature in each section prevent separation of the tool; once snapped into place, the buttons securely lock into position

- Retract to approximately 5 ft. so that they can be carried on most trouble trucks, often in the cab section
- Heavy duty, spring-loaded plastic buttons keep the extended tool sections securely locked in position
- As each section is extended and twisted slightly, the buttons pop into place, allowing working to be done with complete control and confidence

A 35' STICK THAT FEATURES BOTH METRIC & ENGLISH UNITS OF MEASUREMENT

Part Number	Chance	Extended Sections	Retracted/Extended Lengths
9702-04236	C4031022EM	8	60"/35'

USA: 1-877-GO ALTEC
(1-877-462-5832)

www.alteconnect.com

Telescoping Grip-All Hot Sticks



- Chance Telescoping Grip-All sticks can replace several conventional clampsticks, reducing the number of clampsticks required on a line truck, saving limited storage space
- Engineered interface between sections ensures that the tool retracts with full control
- Close fit also helps keep out dirt and moisture
- Top section is made of foam-center Epoxiglas® insulated pole
- Basic clampstick functions of this telescoping style are identical to the fixed-length style
- All controls can be manipulated while wearing gloves
- Easy to disassemble, the Telescoping Grip-All stick must be kept clean and dry inside and out for maximum personnel protection
- Available in two sizes, each readily locks at variable lengths



Telescoping Style with Universal Fitting



- Readily locks at variable lengths
- Design features a rotating coupler and an engineered positive lock button with safety stop to keep the sections from parting or the hook from releasing while in use; the mechanism locks the sections into a solid and rattle-free tool

Part Number	Chance	Extended Lengths	Retracted Length
9000-33060	C4033060	5'6 3/4", 6'9 1/2", 8'0"	5'2 3/4"
9000-33061	C4033061	8' 6 3/4", 10'4 3/4", 12'2 3/4", 14'0"	8'3 3/4"

Part Number	Chance	Extended Lengths	Retracted Length
9000-31025	C4031035	5'6 3/4", 6'9 1/2", 8'0"	5'2 3/4"
9000-31036	C4031036	8' 6 3/4", 10'4 3/4", 12'2 3/4", 14'0"	8'3 3/4"

Please contact 1-877-GO ALTEC (1-877-462-5832) for additional information regarding Chance products.

TELESCOPING HOT STICKS

Telescoping Epoxiglas® Disconnect Tools



- Maximum convenience for the lineman because they permit the performance of many routine jobs from ground level
- Universal end fitting on the insulated top section accepts a wide variety of attachments so the lineman can disconnect switches, replace cutout tubes and reclose, remove pole covers, prune trees, replace bulb. and complete many other overhead tasks
- Retract to approximately 5' so that they can be carried on most trouble trucks, often in the cab section
- Heavy duty, spring-loaded plastic buttons keep the extended tool sections securely locked in position
- As each section is extended and twisted slightly, the buttons pop into place, allowing work to be done with complete control and confidence
- Offered in both standard and heavy duty models
- Both units use the same telescoping tube design

- Tip section of the heavy duty units is slightly larger in diameter (1 1/4" versus 1 1/16") so that each telescoping tube is slightly larger, resulting in a more rigid tool when fully extended, important where additional weight may be frequently encountered on maintenance tasks
- Both tip sections employ time-proved Epoxiglas®, the unicellular foam-core material where the epoxy reinforced fiberglass wall is built around the foam core to prevent any moisture trapping voids that could build up between foam and tool

Standard Duty (1 1/16" Diameter Tip)

Part Number	Chance	Retracted Extended Lengths	Base Length	Diameter	Sections
9000-31023	C4031023	8'	56"	1 1/4"	2
9000-31017	C4031017	8' - 12'	57"	1 1/2"	3
9000-31018	C4031018	12' - 16'	59"	1 11/16"	4
9000-31019	C4031019	12.5', 16.5', 20'	61"	1 7/8"	5
9000-31020	C4031020	16.5', 20.5', 25'	63"	2 1/16"	6
9000-31021	C4031021	17.5', 21.5', 25.5' 30'	65"	2 1/4"	7
9000-31022	C4031022	22', 26', 30.5', 35'	67"	2 1/2"	8
9000-33349	T4033349	22', 28', 34', 40'	74.5"	2 1/2"	8

Compact Standard Duty (1 1/16" Diameter Tip)

9000-32205	T4032205	8'	26"	1 7/8"	5
9000-31739	C4031739	14', 17', 20', 23'	48"	2 1/2"	8
9000-33350	T4033350	12'	40"	1 11/16"	5
9701-28502	T4033240	11'	36"	1 11/16"	4

Heavy Duty (1 1/4" Diameter Tip)

9000-31597	C4031597	8'	56"	1 1/2"	2
9000-31598	C4031598	8', 12'	57"	1 11/16"	3
9000-31599	C4031599	12', 16'	59"	1 7/8"	4
9000-31600	C4031600	12.5', 16.5', 20'	61"	2 1/16"	5
9000-31601	C4031601	16.5', 20.5', 25'	63"	2 1/4"	6
9000-31602	C4031602	17.5', 21.5', 25.5', 30'	65"	2 1/2"	7

Disconnects and Universal Sticks Heavy-Duty Adjustable Sticks



Switch Universal Disconnect

- Clearly marked at each 1' extension lock, one of these Chance tools can replace as many as eight single-length hot sticks
- Especially for such tight confines as substations, these adjustable sticks can be stored in standard-length canisters and avoid the difficulties of working extra-long sticks through busswork structures
- Classified as heavy-duty due to their large (1 1/4" diameter) insulated top section and 1 1/2" O.D. epoxy reinforced fiberglass base tube
- In each size, a 2' section of the Epoxiglas® foam-core top section remains inside the base section at the longest locked, usable length
- At the shortest locked length, the insulated top section extends a full 2' beyond the base
- High-strength plastic buttons keep tools locked at specific lengths

Disconnect-Style NEMA Head:

Part Number	Chance	Lockable Lengths	Collapsed
9000-32600	C4032600	10, 11, 12, 13, 14'	8' 2 3/4"
9000-32601	C4032601	12, 13, 14, 15, 16, 17, 18'	

Switch-Style NEMA Head:

Part Number	Chance	Lockable Lengths	Collapsed
9000-32602	C4032602	10, 11, 12, 13, 14'	8' 2"
9000-32603	C4032603	12, 13, 14, 15, 16, 17, 18'	

Universal Fitting Style:

Part Number	Chance	Lockable Lengths	Collapsed
9000-32604	C4032604	10, 11, 12, 13, 14'	8' 3 3/4"
9000-32605	C4032605	12, 13, 14, 15, 16, 17, 18'	



Above: Universal Disconnect Head (P/N 9000-44559) must be ordered separately for universal-fitting style sticks

HOT LINE EQUIPMENT

USA: 1-877-GO ALTEC
(1-877-462-5832)

www.alteconnect.com

DISCONNECTS/UNIVERSAL STICKS

Sectional Disconnect and Universal Tools

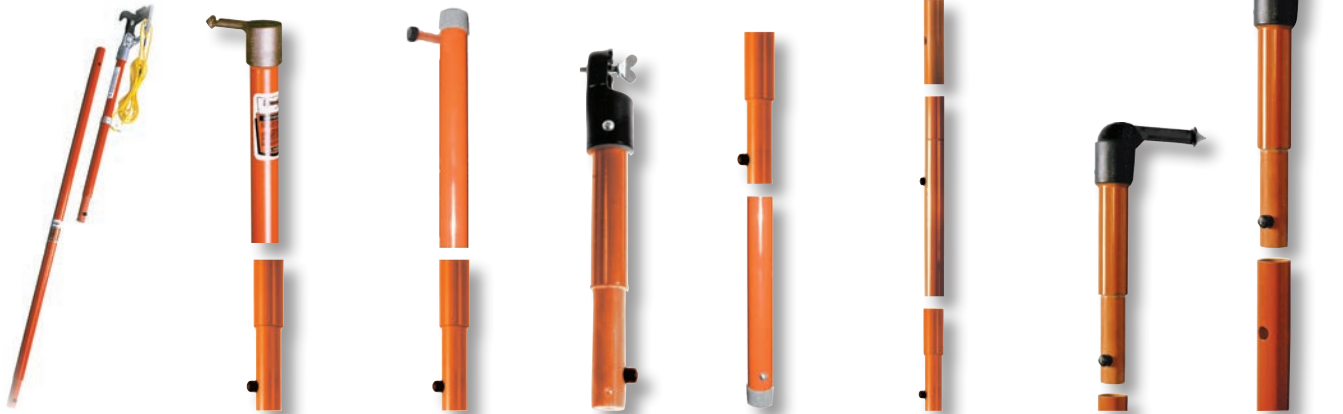

Tree Trimmer Standard Switch Head Disconnect Non-Metallic Disconnect Plastic Universal Base Cap Extension Sections (Both Sizes: 4', 6', 8' and 10' lengths, with female fitting at top and male fitting at bottom) Standard Disconnect Standard Universal

1 1/4" Diameter Poles

Standard Switch Head Disconnect

Part Number	Chance	Description
9000-32073	C4032073	6"
9000-32053	C4032053	4'
9000-32054	C4032054	6'
9000-32055	C4032055	8'

Non-Metallic Disconnect Head

Part Number	Chance	Description
9000-32095	C4032095	6"
9000-32059	C4032059	4'
9000-40320	C4032060	6'
9000-32061	C4032061	8'

Plastic Universal Head

Part Number	Chance	Description
9000-32071	C4032071	6"
9000-32046	C4032046	4'
9000-32047	C4032047	6'
9000-32048	C4032048	8'

Tree Trimmer Head

Part Number	Chance	Description
9000-32096	C4032096	*2'
9000-32097	C4032097	*4'

*Length excludes trimmer head fitting

Extension Section

Part Number	Chance	Description
9000-32062	C4032062	4'
9000-32063	C4032063	6'
9000-32064	C4032064	8'
9000-32133	C4032133	10'

Base Cap

Part Number	Chance	Description
9000-32069	C4032069	5"

1 1/2" Diameter Poles:

Standard Disconnect Head

Part Number	Chance	Description
9000-32074	C4032074	6"
9000-32056	C4032056	6'
9000-32057	C4032057	8'
9000-32058	C4032058	10'

Standard Universal Head

Part Number	Chance	Description
9000-32072	C4032072	6"
9000-32049	C4032049	4'
9000-32050	C4032050	6'
9000-32051	C4032051	8'
9000-32052	C4032052	10'

Extension Section

Part Number	Chance	Description
9000-32065	C4032065	4'
9000-32066	C4032066	6'
9000-32067	C4032067	8'
9000-32068	C4032068	10'

Base Cap

Part Number	Chance	Description
9000-32070	C4032070	5"

Please contact 1-877-GO ALTEC (1-877-462-5832) for additional information regarding Chance products.

HOT LINE EQUIPMENT

USA: 1-877-GO ALTEC
(1-877-462-5832)

www.alteconnect.com

DISCONNECTS/UNIVERSAL STICKS

HOT LINE EQUIPMENT

**USA: 1-877-GO ALTEC
(1-877-462-5832)**

www.alteccconnect.com

- Provide insulation safety for linemen in opening and closing disconnect switches and cutouts
- Poles are made of Epoxiglas® and NEMA-standard heads of cast bronze
- Splice disconnects are convenient for hauling, strong and rigid, easy to put together, and easy to take apart
- Fiberglass head disconnect stick gives the additional insulation required for work where bus and disconnect switch spacings are confined, as in indoor substations

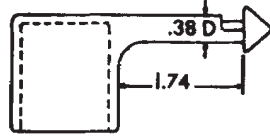

1 1/4" Switch Stick Head

Part Number	Chance	Description
9000-03046	H3046	Head Only
9000-30461	H3046-11	1/4" x 4'
9000-30462	H3046-12	1/4" x 6'
9000-30463	H3046-13	1/4" x 8'
9000-30464	H3046-14	1/4" x 10'
9000-30467	H3046-17	1/4" x 12'

Fiberglass Head

Part Number	Chance	Description
9000-56403	H3046-5	1 1/4" x 4'
9000-66403	H3046-6	1 1/4" x 6'
9000-76403	H3046-7	1 1/4" x 8'
9000-86403	H3046-8	1 1/4" x 10'
9000-96403	H3046-9	1 1/4" x 12'



1 1/2" Disconnect Head

Part Number	Chance	Description
9000-26403	H3046-2	Head Only
9000-22403	H3046-22	1 1/2" x 6' 1"
9000-32403	H3046-23	1 1/2" x 8' 1"
9000-42640	H3046-24	1 1/2" x 10' 1"
9000-30465	H3046-15	1 1/2" x 12' 1"
9000-30466	H3046-16	1 1/2" x 16' 1"
9000-30468	H3046-18	1 1/2" x 18' 1"
9000-06403	H3046-20	1 1/2" x 20' 1"

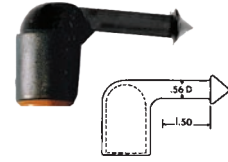

1 1/4" Spliced Disconnect Head

Part Number	Chance	Description
9000-21641	H3146-12	1-1/4" x 6' & 1-1/2" x 6' 1"
9000-61641	H3146-16	1-1/4" x 8' & 1-1/2" x 8' 1"
9000-81641	H3146-18	1-1/4" x 8' & 1-1/2" x 10' 1"
9000-02641	H3146-20	1-1/4" x 10' & 1-1/2" x 10' 1"
9000-42641	H3146-24	1-1/4" x 12' & 1-1/2" x 12' 1"

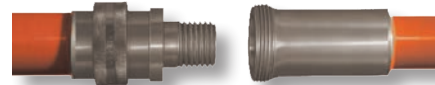

Part Number	Chance	Description	Pole Diameter x Length
9000-01760	H1760	Pole; (1) Universal Head	1 1/4" x 8' 2"
9000-17601	H1760-1	Pole; (1) Universal Head	1 1/4" x 6' 1"
9000-17620	H1760-2	Rigid splice pole; (1) universal head	1 1/4" x 4' 1"
9000-17630	H1760-3	Pole; (2) universal heads	1 1/4" x 6' 3"
9000-46788	H1760-4	Pole; (2) universal heads	1 1/4" x 8' 3"
9000-17660	H1760-6	Rigid splice pole; (2) universal heads	1 1/4" x 4' 1"
9000-17600	H1760-10	Pole; (2) universal heads	1 1/4" x 10' 3"
9000-17602	H1760-12	Pole; (2) universal heads	1 1/4" x 12' 3"
9000-17604	H1760-14	Pole; (2) universal heads	1 1/4" x 14' 3"
9000-01761	H1761	Spline storm tool (2) skirts	1 1/4" x 8' 2"
9000-01770	H1770	Hinged pole; (2) universal heads	1 1/4" x 8' 2"
9000-17908	H1790-8	Pole; (2) universal heads, pole hanger	1 1/4" x 8' 3"
9000-17910	H1790-10	Pole; (2) universal heads	1 1/2" x 10' 3"
9000-17912	H1790-12	Pole; (2) universal heads	1 1/2" x 12' 3"
9000-04455	H4455	Universal head only	1 1/4"
9000-44550	H4455A	Universal head only	1 1/2"

Universal Poles



- Designed for use as a hot stick handle for Universal Tools
- Made of Epoxiglas® and lightweight aluminum castings
- Universal Tools on this page fit under the thumbscrew of the spline on the Universal Pole for a rigid hot stick tool
- For job versatility, the splines allow angling the tool up to 90° in relation to the pole depending upon the individual tool design
- The Storm Tool, a Universal Pole with special rubber insulator skirts, is designed for emergency use, providing extra leakage distance and disrupting water paths when rain, sleet, or snow make regular tools hazardous
- Skirts break up streams that would otherwise run down the pole

Photos to the Left:
Left: P/N 9000-17640
Right: P/N 9000-01761

Photos to the Right:
Left photo: Hinged Pole
Middle photo: Spliced Pole
Right photo: Universal Fitting for Spliced Poles



Please contact 1-877-GO ALTEC (1-877-462-5832) for additional information regarding Chance products.

TOOL KITS

Tool Kits for Insulators

With over 75 individual Chance Universal Tools to select for various maintenance jobs, these kits are a convenient way of ordering. With one catalog number shipped in a single carton, these tools are most frequently used by hot stick crews. Although all Universal Tools are still available as individual part numbers, ordering one or more of the following kits will cover most tool requirements.

Tool Kit for Clevis Type Insulators

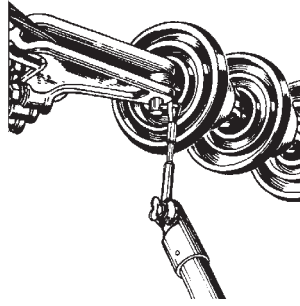

Kit includes:

- Pin Holder
- Cotter Key Remover
- Cotter Key Installing Tool
- All Angle Pliers
- Clear Vision Mirror
- Cotter Key Tool
- Shepherd Hook
- Insulator Fork
- Universal Adapter
- Locating Pin

- This 10-piece kit contains the Universal Tools normally used to handle cotter keys, bolts and insulator hardware for insulator control on Clevis-tongue type suspension or dead-end insulator strings.

P/N 9000-31112 C4031112

Tool Kit for Ball Socket Insulators

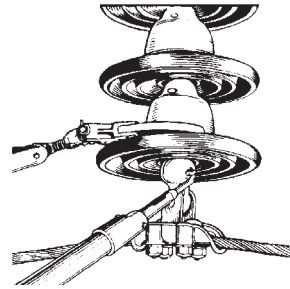

Kit includes:

- Cotter Key Remover
- Cotter Key Pusher
- Ball Socket Adjuster
- Insulator Fork
- Ball Socket Cotter Key

- 7-piece kit contains those Universal Tools required to handle cotter keys, bolts and hardware on ball and socket type suspension or dead-end insulator

P/N 9000-31113 C4031113

Universal Tool Kits

Epoxiglas® Torque Extension Stick



- Permits hot line work with hydraulic power tools on bucket trucks
- 7/16" hex quick connect fitting couples with power tool drive sockets
- Square detent ball fitting accepts all 1/2" drive wrenches
- 1/4" x 4' Epoxiglas® pole handguard is 6" from the ferrule with hex fitting

P/N 9000-33009 T4033009

Flexible Heavy Duty Insulated Wrenches



- Standard square socket on lower end accepts 1/2" square-shank ratchet or similar hand tools
- Square shank on upper end fits any 1/2" drive socket
- Tightens nuts on hardware fittings on high-voltage lines when mounted on 1 1/2" diameter Epoxiglas® extensions
- Coil spring around the universal joint limits flexibility so operator maintains control over the socket at various angles
- Spring removes easily for lubrication



9000-32137	C403-2137	75 ft. lb.	6' 3" length
9000-32136	C403-2136	75 ft. lb.	8' 3" length

Hex Socket Sets



- Each set includes sockets to fit and 1/2" square-shank drive tool

P/N 9000-31085 C4031085

11 deep-well 6-point sockets in sizes 1/2" through 1 1/8"

P/N 9000-31086 C4031085M

10 deep-well 6-point sockets in sizes 10 mm through 19 mm

Please contact 1-877-GO ALTEC (1-877-462-5832) for additional information regarding Chance products.

TOOL KITS

HOT LINE EQUIPMENT

Flexible Insulated Wrenches



- Tightens nuts on hardware fittings on high voltage lines
- Universal joint coil spring provides control over the socket at various angles
- Spring is easily removed for lubricating
- Wrenches fit any 1/2" square-shank socket
- Chance sockets are deep throated and accurately broached
- All wrenches are mounted on 1 1/2" diameter Epoxiglas® poles



Photos:
P/N 9000-18912 Left
P/N 9000-66780 Right

P/N 9000-18912 Chance H1891-2 6' 3" long
Features a flexible 1/2" sq. plug and a fixed 1/2" sq. plug

P/N 9000-18913 Chance H1891-3 8' 3" long
Features a flexible 1/2" sq. plug and a fixed 1/2" sq. plug

P/N 9000-18915 Chance H1891-5 6' 3" long
Features a flexible 1/2" sq. plug and a universal head with a hole through the ferrule for a 5/8" turning rod

P/N 9000-18916 Chance H1891-6 8' 3" long
Features a flexible 1/2" sq. plug and a universal head with a hole through the ferrule for a 5/8" turning rod

P/N 9000-66780 Chance 066780 Ratchet Wrench

Arc Snuffer Removal

Arc Snuffer Removal/Replacement Tools



- Without de-energizing URD bushings, these two Chance hot line tools permit easy retrieval of broken arc snuffers and installation of replacements
- Designed to ensure adequate electrical clearances, both tools are to be used expressly in a Grip-All clampstick
- Integral ring on each tool retracts into clampstick
- Tool bodies are high-impact plastic with steel inserts
- The removal tool works on the principle of a bolt extractor; inserted into a damaged arc snuffer, it permits retrieval by unscrewing the broken part
- The replacement tool controls alignment with a spring-action center post that snaps into the arc snuffer bore
- Two steel lugs of the tool engage holes in the snuffer collar to transmit tightening torque

Part Number	Chance	Description
9000-30236	C4032036	Removal Tool
9000-30237	C4032037	Replacement Tool

USA: 1-877-GO ALTEC
(1-877-462-5832)

www.alteccconnect.com

Please contact 1-877-GO ALTEC (1-877-462-5832)
for additional information regarding Chance products.

ELBOW PULLER TOOLS

Impact Elbow-Puller



- 1 1/4" diameter orange Epoxiglas® pole; for balance, the 5 lb. slide hammer is Plastisol coated and flared at both ends
- Tool and grippers help the operator control the elbow and stiff underground cable lead
- Employs a slide-hammer mechanism to easily disengage and assist in replacing elbows
- For secure handling, both front and rear handgrip areas of the pole are coated with Griptread, a grit-filled rubber-base paint
- The 6' and 8' units meet OSHA requirements with 25" and 48" of insulation respectively from the tool end to the handguard
- On the 4.5' unit (labeled "For Rubber Glove Use Only"), insulation length measures 5"

Part Number	Chance	Length
9000-31822	C4031822	6'
9000-31850	C4031850	8'
9000-31851	C4031851	4.5'

Elbow Connector Tool Grippers



- Provide a sure grip for installing and disconnecting elbow terminators
- The tool grabs the elbow and has a special integral hook that fits through the rubber eye of an elbow or the metal hook of a bushing cap so that the lineman has complete, positive control, overcoming the resistance of the stiff underground cable

Part Number	Chance	Description
9000-30704	C4030704	15 kV Plastic-Coated
9000-30613	C4030613	25 kV Plastic-Coated
9000-30614	C4030614	25 kV Uncoated
9000-30814	C4030814	34.5 kV Plastic-Coated*

* Fits 200 Amp Large Interface and 600 Amp T-Body

Trouble Shooter Equipment

Chance Multi-Duty Trouble Shooter Kit

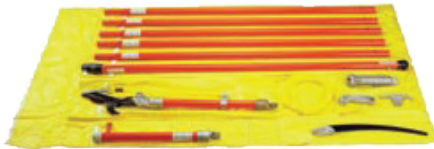

- Includes (6) 4' sections of field proven 1 1/4" Epoxiglas® Universal Pole that snap together
- Butt section features a Plastisol end cap
- Spring-loaded locking buttons permit uses at 4', 8', 12', 16', 20', and 24' lengths
- Fitting on top section with thumbscrew accepts the Universal Accessories included in the kit

Part Number	Chance	Description
9000-31612	C4031612	Complete Kit
9000-32046	C4032046	Top Section Epoxiglas® Pole
9000-32062	C4032062	Mid Section Epoxiglas® Pole
9000-44559	M4455-9	Aluminum Disconnect Head
9000-31614	E4031614	Non-Metallic Disconnect Head
9000-44552	M4455-29B	Clamp Stick Head
9000-21064	H2106-4	Tree Trimmer
9000-44556	C4032213	Pruning Saw
9000-44566	M4455-66	Pistol Grip Saw Handle
9000-32996	P4032996	Storage Case

The kit includes the following:

- Aluminum Disconnect Head for opening and closing switches, opening enclosed cutouts, etc.; has built in hanger hook
- Non-Metallic Disconnect Head provides additional insulation for indoor substations where buswork and switches are in close proximity. Plastisol cap at top; 19" overall length with 15" long Epoxiglas® section
- Clamp Stick Head for use with 6" lone eyescrew ground clamps has locking ring with detent ball for on-off operation. Made from aluminum alloy
- Tree Trimmer adds 1 1/2' to reach with 3-to-1 mechanical advantage pulley and 25' of furnished rope. Offset universal fitting on trimmer accepts pruning saw
- Pruning Saw with deep-notched teeth for quick pullouts attaches directly to top pole, tree trimmer or pistol grip
- Pistol Grip Saw Handle is for use when limbs can be reached and insulation is not needed. Made from aluminum alloy
- Storage Case of yellow heavy-duty vinyl-impregnated fabric has separate pockets for individual tools and Velcro® flap closures

Please contact 1-877-GO ALTEC (1-877-462-5832) for additional information regarding Chance products.

LINK STICKS

HOT LINE EQUIPMENT

USA: 1-877-GO ALTEC
(1-877-462-5832)

www.alteconnect.com

Strain Link Stick



- On deadend structures and running corners, a Strain Link Stick is used as insulation between rope blocks and a cum-a-long clamp
- To supplement wire tongs, a Strain Link Stick is attached to the conductor close to the wire tong and helps support the load
- Also used to support the middle conductor on H-frame structures during insulator or crossarm changes
- Hooks and ferrules are made of heat treated aluminum alloy for the best ratio of high strength to light weight
- Butt rings, for attaching rope blocks or hand lines, are forged of high quality steel
- Butt swivel spins freely on ball thrust bearing
- Edges of the jaws of Chance Link Sticks are rounded to prevent scarring of conductors
- 1.5" diameter x 6' long (overall length of 81")
- Duty - 6,500 lb.
- Jaw Size - .44" to 1.06"

P/N 9700-53373 H47163

Adjustable Strain Pole



- Key to many transmission and EHV maintenance jobs
- Helps support conductors while insulators are removed and replaced
- May be used with yoke plates and hook assemblies at the conductor and structure ends of suspension, V-string or deadend insulator strings
- To support the hot-end trunnions or hooks, 5 stainless steel crosspins are located at 6" intervals on the 2" diameter Epoxiglas® poles
- To engage deadend and suspension yokes at the hot end also requires the adjustable pole clamp of heat treated aluminum; this pole clamp can be unlocked and positioned by hot sticks
- On the cold end, a high-strength steel strain-jack with bronze tongue provides take-up with a ratchet wrench and trunnions
- Wrench and trunnions must be ordered as separate items
- Standard strain jack furnished with each strain pole provides 12" of adjustment. Longer strain jacks (for 24" or 36" of take-up) and extra pole clamps also may be ordered
- 7' long (8'8" overall length)
- Maximum voltage use: 169 kV
- Insulated section: 48"

P/N 9700-53442 C4012145

Crossarm Link Stick

- 1-1/4"-diameter Epoxiglas® pole with 21-1/2" insulating length
- 1,500lb.-rated working load
- Plastisol-coated 3/4"-diameter steel hook
- Hook's 5" opening fits standard 3-3/4" x 4-3/4" crossarms
- Galvanized-steel swivel eye on pole end for easy alignment
- Lifting eye on hook fitting for positioning by a hot line tool

Roller Link Stick



- Used to spread and hold conductors aside at midspan when relocating poles
- Used for measuring conductor-to-ground clearance by attaching a measuring tape or length of rope to the butt ring
- Poles for Roller Link Sticks are 1 3/4"; rotating the pole closes the hook, leaving the head free to roll along the conductor

P/N 9700-53441 H47146

82" Overall Length

Spiral Link Stick



- Used in lieu of a strain link stick in close places where the lineman cannot safely install a strain link stick by hand
- A lifting eye on the head ferrule enables the lineman to guide the Spiral Link Stick to the conductor with a hot stick
- The pole of the Spiral Link Stick is made of 1 1/4" Epoxiglas®
- Ferrule castings are of heat treated aluminum alloy; spiral hook and butt ring of galvanized steel
- 1.25" diameter
- Duty - 3,500 lb.
- Wire size: 1510.5 kcmil ACSR
- 3.43 lb.

P/N 9700-53374 H4722

27.5" Overall Length

P/N 9700-53440 C4000812

57.5" Overall Length

Suspension Link Stick



- The Suspension Link Stick is designed for use on conductors from 1" to 2.5" diameter and can be used with various types of takeup devices at the structure end
- The lip of the hook, actuated by an eye screw, swivels to accommodate various conductor sizes
- The maximum load is 6,500 lb.

P/N 9700-53770 H472084 84" Length

Insulated Link Stick



- Insulates hoists from energized conductors
- 1.25" diameter Epoxiglas® pole has a steel hook on end and a butt swivel on the other
- The maximum load is 4,000 lbs.

P/N 9700-58413 C4002399

18" of Glass



P/N 9706-40810 PSC4004132

Please contact 1-877-GO ALTEC (1-877-462-5832)
for additional information regarding Chance products.

HOT STICK CARE AND STORAGE

Epoxiglas® Cleaning Kit



- Includes essential items for the care and maintenance of Epoxiglas® tools and insulated boom sections of aerial lift trucks
- Proper use of these maintenance aids will ensure that maximum and useful life is obtained from Epoxiglas® products

P/N 9000-99871 C4002365 Epoxiglas® Cleaning Kit

The kit consists of four parts:

Moisture Eater II - Should be used on contaminated Epoxiglas® during general tool maintenance and in preparation for reglossing a tool's surface. Moisture Eater removes moisture and a wide variety of contaminants such as dirt, tar, grease, tree sap, light metal rubbings and old surface coatings without harming the Epoxiglas® material.

Abrasive Cleaning Pads - Pads are used in conjunction with Moisture Eater II to remove contamination that clings to the tools surface. Gloss restorer must be applied after using these pads since cleaning with Moisture Eater II will remove the glossy finish on the tool as well as contamination. The pads may also be used on metal parts to remove oxides and surface corrosion.

Gloss Restorer Kit - When mixed and applied to the surface of a cleaned Epoxiglas® tool, they combine to form a clear, tough coating that replaces the original gloss and protects against contamination and moisture.

Hot Stick Wiping Clothes - Silicone impregnated cloths are used to wipe down mildly contaminated Epoxiglas®, removing dust and dirt, and depositing a thin protective film on the surface of the tool. They give an added measure of protection when used after recoating with gloss restorer.

WARNING: Do not use on Gel-Coat or painted boom surfaces

Moisture Eater II Cleaner-Solvent



- Cleans contaminated Epoxiglas® found on hot line tools, line hose and blankets
- Consists of two solvents: one for oils, waxes and silicone-type contamination; one for moisture contamination
- Free of chlorinated hydrocarbons

P/N 9000-99613 C4002364

Moisture Eater II Wipes



- Small pocket-size packets help utilities stay in compliance with OSHA 29 CFR 1910.269 (j)
- Sealed wipes mean no more rags to store or try to keep clean in the field; no more jugs to stow, big spills, evaporation losses or wasteful excesses just to wet large cloths
- The hanger box holds 50 wipes

P/N 9000-02538 C4002538 Moisture Eater Wipes (Box of 50)

Silicone Wipes For Hot Line Tools



- Small pocket-size packets help utilities stay in compliance with OSHA 29 CFR 1910.269 (j)
- The hanger box holds 50 wipes
- Sealed wipes mean no more rags to store or try to keep clean in the field
- Chance silicone 8" x 10" wipes contain the same silicone that

impregnates hot stick wiping cloths in the Epoxiglas® Cleaning Kit

- Removes dust and deposits a thin protective coat
- P/N 9000-02568 C4002568 Silicone Wipes (Box of 50)

Please contact 1-877-GO ALTEC (1-877-462-5832)
for additional information regarding Chance products.

HOT LINE TOOL ACCESSORIES

HOT LINE EQUIPMENT

Universal Insulator Fork Tool



- Designed to grasp 9" and 10" disk insulators used in deadend construction, will raise most pin type insulators up to 15 lb.
- Fiber jaws open and close by rotating screw.
- Adjustable insulator forks
- 3" to 4.5" opening

P/N 9000-45567 M4455-67

Ratchet Wrench Tool



- Designed for tightening square nuts on 5/8" pole line hardware, regardless of the length of the bolt running beyond it
- The long socket permits wrench handles to swing past crossarm when tightening top ridge pin nut

P/N 9007-44558 M4455-89

Tie Back Clamp



- Installs with a Grip-All clampstick
- Used with a Tension Puller to keep the tail of a conductor out of the work area by tying it back to the main line after it has been cut
- The clamp also may be used to hold a jumper on the main line while applying a compression connector

P/N 9000-46000 C4000600

Universal Tool Adapter



- When this adapter is mounted on a universal stick and any universal tool is mounted on the adapter, the tool can be set at almost any angle to the stick
- Useful for working in close places
- 90° universal tool

P/N 9000-44558 M4455-84

Tie Wire Claw Tool



- Hand-like hot line tool easily and neatly applies tie wires, both factory-formed and field-formed
- Claw controls wire with grip equal to pliers, permits securely wrapping tight coils onto conductors

P/N 9007-31416 C4031416

Skinning Knife



- For cutting or scraping insulation, cleaning conductors, etc., prior to making splices
- Use with a universal pole permits work near energized lines with safety

P/N 9700-40975 M4455-50

Universal Utility Head Tool



- Gator-look shape makes this tool popular for many hot line jobs: placing and removing blocks, slings, circuit breakers, line hooks and strain breakers

P/N 9007-40314 C4031417

Flexible Wrench Head



- Made to fit standard wrench sockets
- Flexibility permits use at various angles

P/N 9007-44554 M4455-46

Hammer Tool



- Used for many operations around energized conductors such as moving conductors, suspension clamps, and other pieces of hardware requiring a forceful blow

P/N 9000-45585 M4455-85

Pole & Clamp Hanger



- Designed for use on 1.25" or 1.5" diameter Epoxiglas® poles
- Includes a black Nylon-filled plastic hook and a steel hose clamp for easy attachment

P/N 9007-17605 H1760-5

USA: 1-877-GO ALTEC
(1-877-462-5832)

www.alteconnect.com

Please contact 1-877-GO ALTEC (1-877-462-5832)
for additional information regarding Chance products.

HOT LINE TOOL ACCESSORIES

Tie Stick Head



- Often preferred for manipulating tie wires which have looped ends
- Useful in close quarters where loose ends of tie wire must be rolled up to prevent contact with crossarm or hardware while untying

P/N 9007-44551 M4455-17

Tie Head



- For manipulating tie wires with or without looped ends
- Heat treated aluminum alloy body design permits a swivel action
- Wire is wrapped or unwrapped without turning universal pole
- A V-notched carbon steel blade grasps tie wire securely

P/N 9007-44557 M4455-70

Tie Head



- For placing insulator ties with looped ends
- Heat treated aluminum alloy body
- Prong swivels freely, permitting a full turn on the tie wire without releasing contact; this minimizes the possibility of kinking or burning the wires

P/N 9007-44556 M4455-69

Ratchet Wrench



- For use with strain jacks and trunnion

P/N 9700-53443 M1948-3

2" Pole Clamp

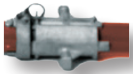

- Replacement pole clamp for adjustable strain pole

P/N 9700-53447 E4010138P

Crossarm Tool Hanger

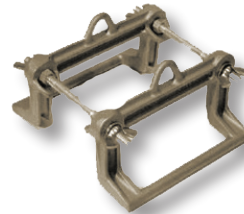

- Adjustable to crossarms ranging in width from 3 1/4" to 4 1/2" (depth of the crossarm does not matter)
- Made of strong, lightweight aluminum alloy
- Features cadmium-plated steel hardware

P/N 9000-01860 M1860

Assembly Trunnions



P/N 9700-53444

P/N 9700-53445

- Trunnions are bronze alloy
- Feature ball-thrust bearing construction for use on adjustable strain poles
- Designed to equal the capacity of all Chance yokes and provide maximum efficiency for the lineman

P/N 9700-53444 E4012068

P/N 9700-53445 E4012066

Ratchet Wrench



- This Ratchet Wrench is used for tightening bolts in substation equipment, hardware bolts on transmission and distribution lines, etc.

P/N 9700-53683 M4455-6

Cleaning Brush



- V-position of brushes gives 2-sided cleaning action
- As brushes wear, they can be rotated, by loosening the anchor screws, so that unused bristles will come in contact with conductor

P/N 9700-53697 M4455-63

Please contact 1-877-GO ALTEC (1-877-462-5832) for additional information regarding Chance products.

HOT LINE TOOL ACCESSORIES

HOT LINE EQUIPMENT

USA: 1-877-GO ALTEC
(1-877-462-5832)

www.alteconnect.com

Cotter Key Removal Tool



- Hammer-like action makes it extremely useful in pulling out stuck cotter keys
- Release of the compression spring by a quick jerk of the pole deals the cotter key a hammer blow without disengaging the eye

P/N 9700-53684 M4455-12

Locating Pin



- Used as a drift pin in aligning bolt holes as an aid in bolt and pin insertions
- It is recommended for making hardware connections on tower transmission lines and line deadends where aligning or hardware fitting is difficult

P/N 9700-53685 M4455-15

Cotter Key Pulling Tool



- Used to partially withdraw a ball-socket cotter key so that the insulator can be removed from another insulator hanger
- This puller with its thin prong is preferred for prying out standard keys deeply set on long insulator strings

P/N 9700-53714 M4455-96

Cotter Key Tool



- For pulling and replacing hump-type cotter keys
- Particularly suitable for use on clevis pins and ball socket insulators
- Easy guiding of cotter key provided by contoured slot and raised eye pin

P/N 9700-53710 M4455-82

Cotter Key Tool



- For ball and socket insulator coupling
- Straight end of the tool enters the socket opening to force cotter key out
- Curved end forces cotter key back into position

P/N 9700-53686 M4455-19

Cotter Key Holder Tool



- Used to install cotter keys into semi-recessed hardware such as found EHV, this tool will hold the keys of the position for proper insertion into clevis pins
- The tool will hold the key firmly, yet readily release once engagement is made

P/N 9700-53720 M4455-103

Mirror Tool



- Angle adjustment enables the operator to inspect insulators, switch bases, and other equipment which is difficult to see without coming in contact with energized conductors

P/N 9700-53694 M4455-38

Hack Saw Tool



- Excellent for use at various angles where a hack saw is needed near energized conductors
- Comes with 10 blades

P/N 9700-53688 M4455-23

Pin Holder Tool



- For replacing pins and bolts
- The bolt head fits into a slot and is held tight by spring action
- Will take bolts or pins up to 5/8" diameter
- Fits EEL and NEMA insulators

P/N 9700-53682 M4455-2

Steel Arm Bracket



- The steel arm bracket is used with the C400-0445 (steel arm yoke) where the steel arm is not equipped with an end plate
- The bracket is made of heat treated aluminum and is complete with a wheel binder
- The steel arm bracket serves the same purpose as an end plate to support the yoke assembly

P/N 9700-53459 T4000838

Please contact 1-877-GO ALTEC (1-877-462-5832) for additional information regarding Chance products.

HOT LINE TOOL ACCESSORIES

Adjuster Socket



- Useful in controlling the adapter between clevis clamps and ball and socket insulator pins

P/N 9700-53687 M4455-22

Link Stick Head



- Use with light conductors
- The clamp will hook into a cum-a-long ring
- Jaw openings range from .750" to .22"
- Jaws have rounded edges to prevent scarring conductors
- The hook is made of heat treated aluminum alloy

P/N 9700-53692 M4455-36

Screwdriver Tool



- Excellent for use at various angles where an insulated handle is needed

P/N 9700-53691 M4455-28

Shepherd Hook



- The self-aligning shepherd hook is designed for pulling and lifting insulator strings
- Swivel action permits it to rotate and maintain its alignment with the insulator at all times
- Heat treated aluminum alloy

P/N 9700-53695 M4455-39

Fuse Puller Tool



- The Chance Fuse Puller may be preset to any position desired and locked there by tightening the wing nut
- A spring assembly also permits the tool to be preset without locking, so that it will align with the fuse during the pulling operation
- Jaws are Plastisol covered

P/N 9700-53699 M4455-77

Screw Jack Assembly



- ACME thread strain jack
- P/N 9700-53448 V4010157 24" Length
P/N 9700-53449 V4010158 36" Length

Hand Guards



- Hand guards assist in maintaining minimum clearances between the hand and the working end of the hot line tool

P/N 9700-53721 C4030799

Clevis Pin Holder



- This tool has particular application on EHV hardware and insulators where the pin must be placed in semi-recessed areas
- The three-finger device is spring-loaded with cadmium plated music wire for positive grip

P/N 9700-53715 M4455-102

Super Hot Rodder Tool



- Ideal for applying line ties and other formed wire products on energized lines
- Adaptable to Super Top-Ties®
- The loop type work end permits rotational control which is difficult with conventional tying tools

P/N 9700-53719 C4031071

All Angle Pliers



- Designed to grasp from any angle
- The jaws are held firmly in position with a wing-nut
- Used as a holding device for retaining bolt heads and loose hardware, adjusting arcing horns, replacing cotter keys, etc.

P/N 9700-53718 C4030177

Please contact 1-877-GO ALTEC (1-877-462-5832)
for additional information regarding Chance products.

HOT LINE TOOL ACCESSORIES

HOT LINE EQUIPMENT

USA: 1-877-GO ALTEC
(1-877-462-5832)

www.alteconnect.com

Yoke for Rectangular or Tri Plates



- May be used with adjustable strain poles to remove the strain from one string of multiple strings of deadend insulators

- Because the yokes are designed to fit various types of yoke plates, they should be purchased in pairs to fit the specific construction
- The same yoke assemblies can be used on both the hot and cold end of the insulator string as they hook into the yoke plate hardware
- Rated at 15,000 lb. maximum load per insulator string
- Distance Between Yokes - 71.5" minimum to 105" maximum
- 20.58 lb.

P/N 9700-53450 C4011717

Deadend Yoke



- Used with Two-Pole Strain Carriers, these units grip compression sleeves over the compressed area, requiring no shoulder or adapter to pull against

- Castings are heat treated aluminum
- When used with 2" adjustable strain poles, this assembly is rated at 11,000 lb. maximum load
- Designed specifically for use on extension links and extruded compression deadends
- A swing up gate exposes the shoe area of the assembly to the load and must be closed before taking up tension
- The assembly can be installed hot on aluminum sleeves crimped with compression dies
- Complete with 4 interchangeable shoes: 24AH Shoes for 477 to 556.5 kcmil ACSR; 30AH Shoes for 715 to 954 kcmil ACSR; 36AH Shoes for 1192.5 to 1351.5 kcmil ACSR and Hot Line Extension Link for 3/4" and 1" diameter shank

P/N 9700-53767 C4010095

Steel Arm Yoke



- Designed for use on the arm of a steel pole, the Steel Arm Yoke mounts over a .75" thick end plate as shown at left
- Swivel castings in the end

of the yoke assure proper alignment of the Chance Strain Poles to the conductor-end yoke

- The load rating is dependent upon the angle of the end plate on the arm; 45° is maximum angle allowed with a maximum load of 9,000 lb.
- In-line loading of the yoke permits a maximum load of 15,000 lb. • Bronze pins place the strain poles 21" apart, center-to-center
- A lifting eye is cast into the top of the yoke for the purpose of landing the yoke upon the end plate of the pole arm

P/N 9700-53457 C4000445

Strain Pole Suspension Yoke with 3.5" Swivel Saddle



- The C401-0168 yoke is used with clevis strain poles
- Fabricated from high strength aluminum plate

- With a maximum load of 15,000 lb. per insulator string, this yoke has two spring-loaded latches which engage and lock the pole clamp into position on the yoke, 26" apart center-to-center, thus providing adequate clearance for corona rings
- An eyebolt, which may be assembled on either side of the yoke, facilitates rigging
- Yoke is equipped with a swivel saddle designed to cope with the variables of suspension strings on running corners
- Saddle will rotate a full 360°
- Saddle will handle conductor yoke plates up to 1" in thickness

P/N 9700-53452 C4011722

Two-Pole Yoke

- Two-pole yokes can be ordered separately to make up any of the two pole strain carriers
- The yokes are fabricated of high strength (.75" and 1" thick) aluminum plate
- The yokes have 26" width between the center of the adjustable strain poles used with them
- Maximum load ratings are 15,000 lb. per insulator string



P/N 9700-53768 C4011720

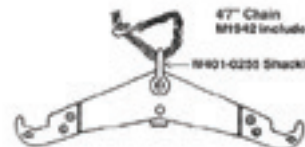

P/N 9700-53769 C4011721

Tower Yoke



- Tower Yoke fits over the tower arm, serving as a support for the Chance Strain Poles to relieve tension on the suspension insulator string through the "hot end" yoke and the conductor yoke plate

- Legs of the yoke are so designed that they can be adjusted to fit most tower structure configurations; still, it is recommended that the design drawings of the tower arms be submitted to Chance with the Tower Yoke order for engineering evaluation to assure a proper fit
- Swivel trunnions are 26" center to center
- Maximum Capacity 12,000 lb.
- 33.32 lb.

P/N 9700-53456 H4783-22

Please contact 1-877-GO ALTEC (1-877-462-5832) for additional information regarding Chance products.

HOT LINE TOOL ACCESSORIES

Spiral Disconnect Tool



- Extremely effective in opening switches and removing and installing cutout doors on porcelain enclosed type cutouts
 - Also called "Pigtail" Disconnect
- P/N 9700-53700 M4455-79

Conductor Cleaning Brush



- Semi-tubular shape allows linemen to clean 6" of entire circumference of conductor with two stick position
- P/N 9700-53713 M4455-92

Adjuster Socket



- Used on heavy socket clevises, particularly where aluminum suspension and deadend clamps are attached to ball and socket insulators
- P/N 9700-53711 M4455-87

Universal Knocker Tool



- Designed to knock out and pull the cotter keys on fog-type insulators, the Knocker Tool is spring assisted for greater impact in restricted space and adverse working conditions
 - The Knocker has a standard universal fitting on one end and a Universal fitting with wing nut on the other end
- P/N 9700-53717 C4030011

Adjustable Hook Assembly

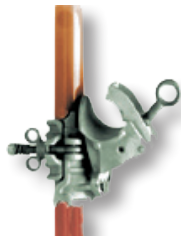

- Adjustable Hook Assembly can be used with the adjustable strain poles as a direct method of relieving the load on a suspension string
 - Conductor clamp has a contoured seat with a trapping gripper and is operated by an eyescrew
 - Conductor range is 1.125" to 2.5" diameter
 - Hook can be positioned every 6" on the strain pole
 - The hook is self-aligning within a range of 45° either side of vertical
 - Maximum load is 3,500 lb.
- P/N 9700-53454 M4724-1

Universal 4-in-1 Cutout Tool



- Strong heat treated aluminum casting
 - For hot sticks with splined universal fitting
 - Gives a clear view of the cutout hinge while placing and removing a fuse holder
 - Performs lift out, placement, opening, and closing of 100 Amp cutout fuse holders made by Chance, and S&C, as well as the Chance Electronic Sectionalizer
 - Weighs only 1/4 lb.
- P/N 9000-40334 PSC4033484

Hot Line Tool Rack



- Eliminates the need for rolls of canvas or other ground covering devices
 - Compact, collapsible racks take up little space on the line truck or in the trailer
 - Tools are protected against abrasion by soft, tough Plastisol coating over arms, center mast
 - All metal parts below the Plastisol are galvanized or bronze for resistance to corrosion
 - The folding tripod-like legs can be locked in the fully opened or fully closed position via an eyebolt, secured by a bead chain
 - Will support up to 12 tools as there are 12 arms to a rack
 - Poles of 3" diameter will easily fit on the arms
- P/N 9700-53678 M4660

Please contact 1-877-GO ALTEC (1-877-462-5832) for additional information regarding Chance products.

LADDERS AND EQUIPMENT

Epoxiglas® Spliced Ladders



- Available in combinations of up to 32'
- 1" diameter steel rods, 8" in diameter, are arched to hook over structural shapes and are furnished on all top section units
- Hooks are complete with steel chains
- Manufactured in short, easy to transport lengths and are joined with the Chance Rigid Ladder Splice to form an unshakable, rigid splice
- Two eye pins in each rail, with a klik pin in the end of each are supplied

P/N 9700-53732 C4020404 14' Top Section W/8" Hook
 P/N 9700-53733 C4020418 8' Bottom Section
 P/N 9700-53734 C4020421 10' Bottom Section
 P/N 9700-53736 C4020422 12' Bottom Section

Epoxiglas® Hook Ladder



- Epoxiglas® Hook Ladders have many applications in high voltage maintenance to position linemen in the most advantageous working location, making line repairs possible at otherwise almost inaccessible places
- Hooks are formed from 1" diameter tempered steel and can be swiveled to best fit various angles on the structure
- Steel chains clip to the hooks to assist in securing the ladder to a support
- Rung material for both rated ladders are 1.25" Epoxiglas® and sand-coated

P/N 9700-53557 H4905-14 12' Overall, 2.5" Side Rails
 14.5" Between Rails

Spreader Bar

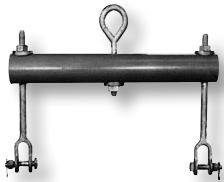

- Quick, easy rigging on most types of structure is the feature of the Chance ladder attachment sets, affording efficient use of the Chance Epoxiglas® ladder as a platform for live-line maintenance
- Designed to be attached to either steel or wood structures, vertical or

horizontal, to support the structure-end of the ladder in a tagged-out position

- Designed for use on 2.5" diameter side rail ladders and can be ordered as sets or choosing the individual components

P/N 9700-53766 E4020099

Standard Aerial Platform



- Designed to provide a convenient workstation on an aerial structure
- Quickly mount in position on the structure to place workers in the correct relationship to the work area
- These platforms are furnished with a Fixed Pole Mount for maintenance jobs that do not require frequent platform relocation
- Pivot Mounts (available as optional accessories) allow the platform to

be swiveled on its horizontal plane to different positions for a certain operations. For belt-on and as restraining guides for workers, Epoxiglas® Tripods or Railings may be added

- For improved footing, three strips of 2" non-skid tape extend the length of the platform working surface
- A bare section near the mounting end helps reduce moisture accumulation in inclement weather and provides an area between the working surface and the mount fittings that can be readily wiped clean of dirt and moisture when necessary

P/N 9700-53562 H4964-6W

Vertical Attachment for Towers

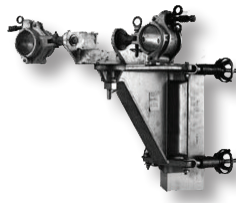

- Quick, easy rigging on most types of structure is the feature of the Chance ladder attachment sets, affording efficient use of the Chance Epoxiglas® ladder as a platform for live-line maintenance
- Sets were designed to be attached to either steel or wood structures, vertical or horizontal, to support the structure-end of the ladder in a tagged-out position

- Designed for use on 2.5" diameter side rail ladders and can be ordered as sets or choosing the individual components

P/N 9700-53561 E4020525

Ladder Attachment Kit

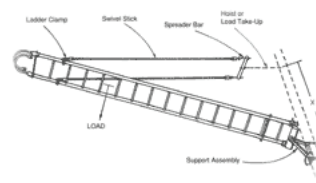

- Quick, easy rigging on most types of structure is the feature of the Chance ladder attachment sets, affording efficient use of the Chance Epoxiglas® ladder as a platform for live-line maintenance
- Sets were designed to be attached to either steel or wood structures,

vertical or horizontal, to support the structure-end of the ladder in a tagged-out position

- Designed for use on 2.5" diameter side rail ladders and can be ordered as sets or choosing the individual components

P/N 9700-53559 C4020155



- Epoxiglas® construction adds belt-on capability and restraining guide for lineworkers

P/N 9700-53676 C4020023

HOT LINE EQUIPMENT

USA: 1-877-GO ALTEC
(1-877-462-5832)

www.alteconnect.com

Please contact 1-877-GO ALTEC (1-877-462-5832) for additional information regarding Chance products.



HASTINGS

A WORLDWIDE SUPPLIER OF
Hot Line Tools & Equipment

Link Sticks

Insulated Spiral Link Stick



- Designed to isolate rope lines, hoists, and rope blocks - providing insulation between energized conductors and pulling devices which might be attached to a different potential
- One-piece, 1" O.D. fiberglass stick has a solid unicellular foam core

- Spiral hook is made from high-strength, heat treated steel
- Maximum wire size: 795 ACSR
- Maximum working load: 2,000 lbs.

Part Number	Hastings	Description
9007-03480	3480	1" x 12" F6 pole 24" overall length
9700-80058	3481	1" x 24" F6 pole 36" overall length
9700-80062	3482	1" x 36" F6 pole 48" overall length
9700-80064	3483	1" x 48" F6 pole 60" overall length

Insulated Link Sticks



- Designed to provide extra protection when using strap hoists on primary voltages
- Fiberglass links help overcome the loss of dielectric properties when the web straps become contaminated through field use
- Can be used with most strap hoists

- Pre-tested to 5,000 lbs. before shipment and tested per OSHA and ASTM F-711
- 1" diameter fiberglass with solid foam core
- Insulated fiberglass shaft and operating rod allow maximum safety and durability

Part Number	Hastings	Description
9700-80067	3413	6" length; 4,000 lb. rating
9700-16176	3414	12" length; 4,000 lb. rating

Shotgun Sticks

Shotgun Sticks & Carrying Case



Photos:

- Folding Shotgun (left)
- Telescopic Shotgun (middle)
- Fixed Length Shotgun (right)

- Constructed of electrical grade fiberglass
- Telescoping models can extend to match all stick lengths
- Extended length spear offers easy method of locating the eye of hot taps that are otherwise difficult to locate
- Larger opening and 5" deep throat

gives greater control on all hot taps, including the new longer stem taps

- New operating rod guide eliminates trapped dirt and moisture, allowing for easier cleaning of inside area of rod guide
- Handle body is made of melron polycarbonate, is non-conductive, extremely durable and unaffected by temperature extremes
- The plastic protective sleeve surrounding the fiberglass tube prevents scuffing
- Full open side hook offers unobstructed vision of the hook
- Hanger hook is molded in the head, eliminating metal parts
- Hook release trigger is shielded
- The precision cast slide offers 13 teeth per inch, giving complete control and an extra firm grip
- The insulated rubber cap protects the base and prevents wear

Telescopic Shotgun

Part Number	Hastings	Retracted Length	Operating Lengths
9000-08158	8158	5'1"	5'1", 6'6", 8'
9000-81814	81814	8'	8', 10', 12', 14'

Telescopic Shotgun with Universal Fitting on Handle

Part Number	Hastings	Retracted Length	Operating Lengths
9000-81580	8158-U	5'1"	5'1", 6'6", 8'
9000-01814	81814-U	8'	8', 10', 12', 14'

Folding Shotgun with External Operating Rod

Part Number	Hastings	Length
9000-13412	13412	6'6"
9000-13413	13413	8'6"
9000-13414	13414	10'6"
9000-13415	13415	12'6"

Fixed Length Shotgun with External Operating Rod

Part Number	Hastings	Length	With Universal Fitting on Base End
9000-08104	8104	4'6"	P/N 9701-11607 (8104-U)
9000-08106	8106	6'6"	P/N 9700-95768 (8106-U)
9000-30293	8108	8'6"	P/N 9700-73529 (8108-U)
9000-08110	8110	10'6"	P/N 9701-11612 (8110-U)
9000-08112	8112	12'6"	P/N 9701-11614 (8112-U)

Carrying Case for Shotgun Sticks

- Water repellant yellow vinyl nylon reinforced ducting
- Carrying strap attached
- Snap type flap on open end

P/N 9000-03500 C-35

Please call 1-877-GO ALTEC for additional carrying cases

HOT LINE EQUIPMENT

USA: 1-877-GO ALTEC
(1-877-462-5832)

www.alteconnect.com

Telescopic Hot Sticks & Cutters

Tel-O-Pole Hot Sticks



- May be used for opening and closing disconnect switches, replacing fuses in porcelain-type cut-outs, pruning tree limbs, or replacing lamps in street circuits
- Made of reinforced high density electrical grade fiberglass laminate with unusual color stability, greater strength and high dielectric properties
- Tubular sections are engineered to allow for air circulation; foam is applied with an exclusive process to eliminate voids between the foam and the tool wall, which eliminates trapped moisture
- Patented interlock feature allows it to be locked in lengths listed by means of one pin locking two or more sections
- The top section on all Tel-O-Pole Hot Sticks is insulated with a fire retardant polyurethane foam core
- Sure-lock joints and corona free discharge heads

Standard Tel-O-Pole Hot Stick, 7/8" Tip Diameter

Part Number	Hastings	Extended Length	Retracted Length	Base Dia.
9000-02120	S-212	12'	44"	1 5/8"
9000-02160	S-216	12'4" - 16'	56"	1 5/8"
9700-52744	S-220	17' - 20'	58"	1 7/8"
9000-02250	S-225	17' - 21' - 25 1/2'	60"	2 3/16"
9000-02300	S-230	17' - 21 1/2' - 26' - 30'	61 5/8"	2 3/8"
9000-02350	S-235	17' - 21 1/2' - 26' - 30' - 35'	63 3/8"	2 11/16"

Heavy Duty Tel-O-Pole Hot Stick, 1 3/32" Tip Diameter

Part Number	Hastings	Extended Length	Retracted Length	Base Dia.
9000-02166	SH-216	9' - 13' - 17'	58 1/8"	1 7/8"
9000-22200	SH-200	13' - 17 1/2' - 21 1/2'	60"	2 3/16"
9000-02500	SH-250	13' - 17 1/2' - 21 1/2' - 26'	61 5/8"	2 3/8"
9000-00230	SH-230	13' - 17 1/2' - 21 1/2' - 26' - 30'	63 3/8"	2 11/16"

Tel-O-Pole Hot Stick with Tip Lock Feature

Part Number	Hastings	Extended Length	Retracted Length	Base Dia.
9000-60220	ST-220	17' - 20'	58"	1 7/8"
9000-02301	ST-230	17' - 21 1/2' - 26' - 30'	61 5/8"	2 3/8"
9700-05496	ST-235	17' - 21 1/2' - 26' - 30' - 35'	63 3/8"	2 11/16"
900-00551	ST-240	17' - 21 1/2' - 26' - 30' - 35' - 40'	63 3/8"	2 11/16"

Combination Tel-O-Pole Measuring Stick



- Heavy duty Tel-O-Pole includes English scale measurement graduations for eye-level reading
- Painted graduations are silk-screen printed directly on the fiberglass sections, and will not chip or peel
- Surface is coated with a hard, high-gloss epoxy finish
- Foot markings are printed in large, easy to read numerals
- Graduations are marked to measure in feet, inches, and 1/2" graduations
- 30' extended; 63 3/8" retracted
- 2 11/16" base diameter; 1 3/32" tip diameter

P/N 9701-81902 EV-30 66" - 30'
P/N 9701-92119 EV-35 68" - 35'
P/N 9701-86722 EV-40 69" - 39' 6"

Tel-O-Pole II - "No Twist" Stick



- All models are heavy duty designed
- Triangle Shape enables each section to lock in automatically
- Fluorescent tip section (1.15" diameter) is highly visible and has a foam core
- Sections are 100% tested per OSHA and ASTM F-711
- Lock Buttons are large easy to operate with or without gloves
- Design allows user to use only the number of required sections to perform each job, allowing for a lighter tool to perform the work more easily
- Easily disassemble by depressing the lock button and sliding the section, or sections, out
- Ergonomic design gives the operator a better gripping surface for improved control
- All sections have a smooth glossy surface for routine cleaning and waxing
- Strong aluminum alloy head incorporates corona discharge design and "includes a captive Belleville washer" to hold universal attachments securely

Part Number	Hastings	Extended Length	Retracted Length	Base Diameter
9000-02080	HV-208	8'	26"	1.75"
9000-20120	HV-212	12'7"	58"	1.45"
9000-20160	HV-216	16'9"	60"	1.61"
9700-72872	HV-230	30'	66"	2.07"
9000-00235	HV-235	35'	68"	2.22"
9000-02424	HV-240	39'6"	69"	2.38"

6' Insulated Ratchet Cutters



- Lightweight and easy to handle
- For both overhead and underground applications
- Provides clean cuts for splicing conductors
- Cuts 666-54/7 ACSR, 1000 MCM aluminum, 500 MCM copper
- Handle folds and cutters store in 6" canister
- Operates in a 5" width trench
- Long reach, remote operation

P/N 9007-11006 Hastings 11-006

6' Hot MD-6



- Lever handled compression tool
- Designed for live line crimping of sleeves and connectors
- Utilizes Burndy "W" dies
- Head features a fixed 5/8" nose die

P/N 9007-12594 Hastings 12594



HASTINGS

A WORLDWIDE SUPPLIER OF
Hot Line Tools & Equipment

Switch & Disconnect Sticks

HOT LINE EQUIPMENT

USA: 1-877-GO ALTEC
(1-877-462-5832)

www.alteconnect.com

Spliced Switch and Disconnect Sticks



- These sticks eliminate storage problems and duplication of tools
- Switch and disconnect heads are made from high tensile cast bronze
- The insulated head is made of fiberglass
- Choose top section and base section and add extension sections as needed

• All stick sections have a solid unicellular foam core and are tested per OSHA and ASTM F-711

UNIVERSAL HEAD

Part Number	Hastings	Length
9000-55474	55547-4	1 1/2" x 4'
9000-55476	55547-6	1 1/2" x 6'
9000-55478	55547-8	1 1/2" x 8'
9000-55471	55547-10	1 1/2" x 10'

DISCONNECT HEAD

Part Number	Hastings	Length
9000-55416	5541-6	1 1/2" x 6'
9000-55418	5541-8	1 1/2" x 8'
9000-55410	5541-10	1 1/2" x 10'

INSULATED HEAD

Part Number	Hastings	Length
9000-05462	5462-2	1 1/4" x 2'
9000-45462	5462-4	1 1/4" x 4'
9000-65462	5462-6	1 1/4" x 6'
9000-85462	5462-8	1 1/4" x 8'

SWITCH HEAD

Part Number	Hastings	Length
9000-05460	5460-4	1 1/4" x 4'
9000-00546	5460-6	1 1/4" x 6'
9000-08546	5460-8	1 1/4" x 8'

EXTENSION SECTIONS

Part Number	Hastings	Length
9000-05464	546-4	1 1/4" x 4'
9000-05466	546-6	1 1/4" x 6'
9000-05468	546-8	1 1/4" x 8'
9000-55464	5546-4	1 1/2" x 4'
9000-55466	5546-6	1 1/2" x 6'
9000-55468	5546-8	1 1/2" x 8'
9000-55461	5546-10	1 1/2" x 10'

Universal Hot Sticks

- Feature a universal head on both ends which adapt to all standard universal fits on tools
- Constructed of a fine grade woven fiberglass material
- Contain a unicellular core, and are fabricated especially to withstand high torque and unusual strength requirements
- The color of these sticks is standard safety yellow, and each universal hot stick has a hanger hook

Part Number	Hastings	Size
9000-46786	4678-6	1 1/4" x 6'
9000-46788	4678-8	1 1/4" x 8'
9000-46781	4678-10	1 1/4" x 10'
9000-46782	4678-12	1 1/4" x 12'
9000-46784	4678-14	1 1/4" x 14'
9000-46808	4680-8	1 1/2" x 8'
9000-46801	4680-10	1 1/2" x 10'
9000-46802	4680-12	1 1/2" x 12'
9000-46804	4680-14	1 1/2" x 14'



Substation Adjustable Disconnect Sticks



- Designed for use in close confines of substations
- Eliminates the problem of threading long sticks through substation structures
- Adjustable to length in 1' increments; therefore multiple length stick requirements are eliminated
- Top section is a conventional 1 1/4" diameter hot stick with fire retardant unicellular core; the top section may also be removed for use as a single one piece hot stick
- Base section is 1 1/2" diameter
- Extended length is shown at each lock position for reference
- The top section must extend beyond the base before the lock will engage, giving full protection of fire retardant unicellular core
- Available with standard NEMA high tensile bronze disconnect head, switch head, or universal head "fit on type"

NEMA Disconnect Head:

Part Number	Hastings	Extended Length	Minimum Length	Collapsed Length
9000-03114	3114	14'	10'	8'4"
9000-03118	3118	18'	12'	10'4"

NEMA Switch Head:

Part Number	Hastings	Extended Length	Minimum Length	Collapsed Length
9000-03115	3115	14'	10'	8'4"
9000-03119	3119	18'	12'	10'4"

Universal Head:

Part Number	Hastings	Extended Length	Minimum Length	Collapsed Length
9000-03116	3116	14'	10'	8'4"
9000-03120	3120	18'	12'	10'4"

Multi-Purpose Holding Tool with Rigid or Adjustable Head



- For holding slack conductors during sleeving; provides positive control for shaping and bending jumpers, buss wires
- Main fiberglass portion is 1" diameter, and is fabricated with finely woven cloth, giving maximum strength with minimum weight and size; 5/8" operating rod is designed to withstand the highest torque obtainable by hand
- Foam filled to eliminate migration of contaminants and moisture
- Conductor capacity #6 - 1 1/16"; tested per OSHA and ASTM F-711
- Adjustable head models also offer the convenience of adjustment from straight to 30° both sides of center

Part Number	Hastings	Size	Description
9000-04601	4601	1" x 6' long	Rigid Head
9000-04602	4602	1" x 8' long	Rigid Head
9700-88936	4603	1" x 4' long	Adjustable Head
9007-04604	4604	1" x 6' long	Adjustable Head
9700-98979	4605	1" x 8' long	Adjustable Head

Switch & Disconnect Sticks

Switch & Disconnect Sticks



Photos:

- 1st: Switch Head
- 2nd: Disconnect Head
- 3rd: Insulated Head
- 4th: Universal Head

- Constructed of woven fiberglass materials
- A special manufacturing technique assures uniformity of glass fiber distribution and full elimination of resin-rich areas which cause chipping and glass fiber peel
- Unicellular core is self-extinguishing and resistant to cleaning fluids and solvents
- Safety bright yellow color is an integral part of the laminate and will not chip or peel
- The hard-gloss, porosity-free epoxy finish is easy to keep clean
- Switch and disconnect heads are made of tough, high-tensile, cast bronze and are designed to NEMA standards
- Insulated head is made of fiberglass with a non-metallic NEMA shaped prong
- All sticks are tested per ASTM F-711, and OSHA

Switch Head

Part Number	Hastings	Length	Weight
9000-04604	460-4	1 1/4" x 4'	1 lb. 9 oz.
9000-04606	460-6	1 1/4" x 6'	2 lbs. 5 oz.
9000-04608	460-8	1 1/4" x 8'	3 lbs.
9000-46010	460-10	1 1/4" x 10'	3 lbs. 4 oz.
9000-46012	460-12	1 1/4" x 12'	3 lbs. 9 oz.
9000-10036	P10036	Head Only	7 oz.

Disconnect Head

Part Number	Hastings	Length	Weight
9000-54160	541-6	1 1/2" x 6'	3 lbs. 3 oz.
9000-54180	541-8	1 1/2" x 8'	3 lbs. 12 oz.
9000-54110	541-10	1 1/2" x 10'	4 lbs. 15 oz.
9000-54112	541-12	1 1/2" x 12'	6 lbs. 10 oz.
9000-54114	541-14	1 1/2" x 14'	7 lbs. 7 oz.
9000-54116	541-16	1 1/2" x 16'	8 lbs. 6 oz.
9000-54118	541-18	1 1/2" x 18'	9 lbs. 4 oz.
9000-54120	541-20	1 1/2" x 20'	10 lbs. 3 oz.
9000-10038	P10038	Head Only	13 oz.

Insulated Head

Part Number	Hastings	Length	Weight
9000-50140	501-4	1 1/4" x 4'	1 lb. 4 oz.
9000-50160	501-6	1 1/4" x 6'	2 lbs. 5 oz.
9000-50180	501-8	1 1/4" x 8'	2 lbs. 10 oz.
9000-50110	501-10	1 1/4" x 10'	
9000-50112	501-12	1 1/4" x 12'	

Universal Head (Includes Hanger)

Part Number	Hastings	Length
9000-05676	567-6	1 1/4" x 6'
9000-05678	567-8	1 1/4" x 8'

Spliced/Stepped Switch and Disconnect Sticks



- Feature metal splice ferrules and solid unicellular foam core
- Tested per OSHA
- Stepped sections allow for long lengths and maintained rigidity
- Provides convenient storage, eliminating long one-piece sticks
- Two section switch stick with metal splice and disconnect head

Part Number	Hastings	Length	Tip	Base
9000-20923	20923	12'	1 1/4" x 6'	1 1/2" x 6'
9000-20925	20925	16'	1 1/4" x 8'	1 1/2" x 8'
9000-20926	20926	18'	1 1/4" x 8'	1 1/2" x 10'
9000-20927	20927	20'	1 1/4" x 10'	1 1/2" x 10'

P.V.C. Hot Stick Canister



6" Diameter Hot Stick Containers

Part Number	Hastings	Length
9000-13350	01-33350	7'
9000-13351	01-33351	9'
9000-13352	01-33352	11'
9000-13353	01-33353	13'
9000-13354	01-33354	15'
9000-13355	01-33355	17'
9000-13356	01-33356	19'
9000-13357	01-33357	21'

- Includes universal mounting brackets for mounting on trucks, fences, etc.
- Constructed of top grade aluminum castings and heavy duty P.V.C. tubing to help prevent sag and the formation of aluminum oxide
- Aluminum end cap is designed to open by merely pulling a pin
- One end of the canister container is completely sealed; the opposite end has an "easy-open" aluminum cap with an "O" ring seal providing weather-tight protection for those many items that must be stored or transported outside

Snap-On Adapters



- Can be used with extension sections for spliced switch and disconnect sticks
- Use of snap-on adapters with extension sections eliminates duplication of fixed sticks and storage problems

Left: Male Universal Adapter
Center: Male Disconnect Head
Right: Female Base Cap

Part Number	Hastings	Description
9000-18007	A18007	Base Cap for 1 1/4" Stick
9000-18008	A18008	Base Cap for 1 1/2" Stick
9000-10025	A10025	Universal Adapter for 1 1/2" Stick
9000-05558	5558	Disconnect Adapter for 1 1/2" Stick

HOT LINE EQUIPMENT

USA: 1-877-GO ALTEC
(1-877-462-5832)

www.alteconnect.com



HASTINGS

A WORLDWIDE SUPPLIER OF
Hot Line Tools & Equipment

Hot Line Tools Cleaning & Repair

HOT LINE EQUIPMENT

USA: 1-877-GO ALTEC
(1-877-462-5832)

www.alteconnect.com

Fiberglass Cleaning/Refinishing Kit



- Kit includes (1) gallon All-Purpose Cleaner, (1) box of 20 Ultra Fine Non-Metallic Abrasive Pads, (1) Qt (2 parts) Clear Epoxy Refinishing Kit Silicone Treated Wiping Cloths
- Use to clean and/or restore fiberglass hot sticks, booms, buckets

P/N 9000-10171 10-171

Hot Stick Wipes



- Excellent for daily wiping of hot sticks
- Remove contaminants such as dirt, oils, creosote, and other undesirable matter
- Leaves a silicone moisture barrier which enables water to "bead up," eliminating the "blanket effect" when using hot sticks in wet conditions
- 50 wipes individually packaged in each heavy duty cardboard dispenser box
- Environmentally safe, the used wipes may be disposed of in normal waste containers

P/N 9000-10188 Hastings 10-188 50 wipes

Hot Stick & Boom Wax



- 14 oz. can
- Protects hot sticks and booms

P/N 7160-30528 10-091 Single Can

P/N 9007-10091 10-091 Case of 6

Extendo Slick

- Helps all your telescopic sticks slide freely
- Reduces friction caused by wear, contaminants
- Non-conductive; non-flammable
- Dries quickly and is long-lasting
- One can will do up to eight 40' telescopic sticks
- Optional spray handle sold separately

P/N 9705-16123 10-088 Single Can

P/N 9705-16128 P31444 Spray Handle



Silicone-Treated Wiping Cloth

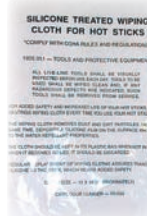

- Deposits a water repellent film while removing dust and dirt particles from the surface of hot sticks and insulated tool handles
- 18"x18" cotton cloth features bound edges and has an open-type weave
- Regular replacement of the silicone-treated cloth will add to the life and safety of the tools

P/N 9000-10090 Hastings 100-90 18"x18"

All Purpose Cleaner

- Excellent cleaner for the following items: Hot line tools, Platforms, Rubber Goods, Rigid Cover-ups, Shop Machinery, Hands, all Plastic Surfaces, Painted Surfaces, Aluminum
- This product is very safe, and is non-toxic, biodegradable, non-alkali, non-flammable, non-acid, and gentle on the skin

P/N 9000-10169 10-169 1 gallon



Bucket Barricade

Hastings Truck Safety Barricade Kit

- Barricade can be installed, positioned, or raised, and removed in minutes. Just drop in place in pre-located permanently attached steel brackets
- Fiberglass arm is easily positioned to adjust barricade for proper height above the ground and to compensate for parking on uneven terrain
- Design allows fiberglass arm to be quickly located in eight different positions
- Arm can be moved to "vertical travel position" when movement of truck for a short distance is required
- All metal components (except steel adapters attached to truck) are stainless steel or aluminum, to reduce corrosion problems from salt atmosphere and winter operations



- P/N 8140-00372 6795 Truck Safety Barrier Kit with 4' Arms
- P/N 9000-99601 6796 Truck Safety Barrier Kit with 6' Arms
- P/N 8140-00371 6798-1 Universal weld on adapter
- P/N 8140-00373 6795-1 4' Fiberglass Arm with Bracket
- P/N 9000-99602 6496-1 6' Fiberglass Arm with Bracket

Truck Safety Barrier Kit Made Exclusively For ALTEC Units:
P/N 9702-91325 See Page 24 or 163 for more information.

Hastings Truck Barricade Arm

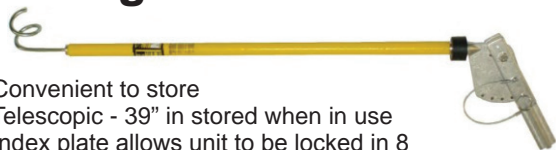

- Convenient to store
- Telescopic - 39" in stored when in use
- Index plate allows unit to be locked in 8 different positions
- Features rubber cushion base that helps prevent breakage in high traffic areas

P/N 7160-30543 6929

Hastings Sliding Barricade Bar

- 51" to 85"
- Telescopic barricade
- High visibility yellow and black
- Ideal visual barricade



P/N 9701-06915 6850

Truck Safety Barricade

Truck Safety Barricade Arm

- Barrier can be installed, positioned, or raised for moving truck and removed in minutes. Just drop in place in pre-located, permanently attached steel brackets
- Fiberglass arm is easily positioned to adjust barricade for proper height above the ground and to compensate for parking on uneven terrain
- Unique design of sector allows fiberglass arm to be quickly locked into 8 different positions from 30° above horizontal to 22 1/2° below horizontal in 7 1/2° increments through the use of quick release pin
- Arm can also be moved to "vertical travel position" when movement of truck for a short distance is required
- Made exclusively for Altec trucks; barricade arms telescope and slide into sockets and feature rope rings

P/N 9701-18724 EX-3729

Sold Individually



Bucket Barricade



- Provides added protection from arcs and flashes while closing cutouts, from oil spray when working around transformers; as a barrier when working in close proximity to energized hardware, and from wind/weather when working in poor conditions.
- Fits any bucket
- Handy tool board included
- Four height adjustments 10", 16", 22", and 28", just lift and barricade locks in position automatically
- Barricade when stowed is down and out of the way

P/N 9703-33356 05-840 18" Wide
P/N 9703-33359 05-841 23" Wide



WARNING: Do not use Barricade as a replacement for primary personal protection, arc and blast protection, or any other safety equipment. Any attempt to do so may result in serious injury or death. This Barricade is to be used along with all safety equipment and safe working practices required by your company and OSHA.

Arm Assembly Equipment

Square Jib Brace Adapter



- For attaching brace to pole
- 4" x 4" F.G. Jibs

P/N 8130-00807
Hastings 3489



5' x 3" O.D. Mast Assembly Only



- Features quick detach pin

P/N 720-30092 Hastings 11683

Self-Aligning Conductor Holder



- For attachment to mast
- Opening is 1 1/2"
- Spring loaded latch is hot stick operable
- Maximum work load 300 lbs.
- For a 3" diameter round jib

P/N 720-30087 Hastings 21642

Jib Mounted Arm Attachment



- Jib adapter for Altec 4.1" x 4.1" square jibs
- Mounts arm assemblies and attachments
- Enables attachments to rotate 360°
- Zinc-plated steel

P/N 8130-00873 Hastings 3479

HOT LINE EQUIPMENT

USA: 1-877-GO ALTEC
(1-877-462-5832)

www.alteconnect.com



HASTINGS

A WORLDWIDE SUPPLIER OF
Hot Line Tools & Equipment

Hot Line Tools & Accessories

HOT LINE EQUIPMENT

USA: 1-877-GO ALTEC
(1-877-462-5832)

www.alteconnect.com

Complete Arm Assembly



- The boom-mounted lift arm may be utilized as a 1 or 3 phase lifting attachment when mounted to derrick trucks and aerial trucks that have lifting capabilities
- May be used for change-out of poles, cross-arms, insulators, and mid-span lifting requirements
- Lift arm can be mounted to a square, rectangular, round, or oval boom by ordering the proper boom adapters and blocks
- Total arc covered is 45°
- Metal components are steel or aluminum alloy

- Boom-mounting assembly features a ratchet, which allows the arm to be positioned under the load
- Fiberglass arm and mast assembly is 3" O.D. with a solid foam core, which are tested per OSHA
- Fiberglass brace is 1 1/2" O.D. with solid foam core and tested per OSHA

Swivel Support



- This support is used to connect the arm assembly to the mast

P/N 0720-30034 Hastings 11974

Brace Pole



- For attachment to arm assembly and mast

P/N 7017-02085 Hastings 12006

Super Duty Conductor Holder



- For attachment to mast and jib adapters
- Accepts 2" diameter conductors
- Maximum working load 500 lbs.

P/N 720-30100 Hastings 12666
P/N 720-30057 Replacement Cable Pin

Jib Head Roller with Sheave

- Aluminum alloy housing with a steel wheel
- Opening is 3" diameter

P/N 720-30036 Hastings 21644



- Load rating - balanced loading with brace is 1,000 lbs. maximum; with arm, unbalanced loading is 200 lbs. per conductor holder*
- * Rating is based on vertical lift; sideloading reduces rating
- * Load rating - If mast only is used with self-aligning conductor holder (P/N 720-30087) or super-duty conductor holder (P/N 720-30100), the load rating is 500 lbs. maximum

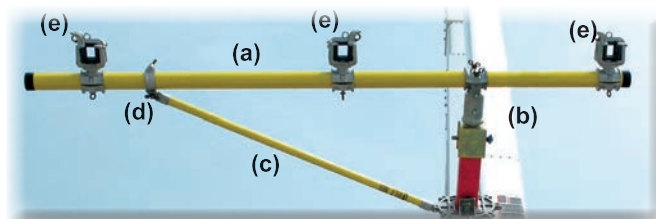

P/N 7017-02080 Hastings 13128 Complete Assembly

Complete Assembly Includes:

- | | |
|--------------------|--------------------------------|
| (a) P/N 9700-52746 | 9' x 3" O.D. Arm |
| (b) P/N 720-30034 | Swivel support |
| (c) P/N 7017-02085 | Brace pole |
| (d) P/N 7160-30535 | (2) brace clamps |
| (e) P/N 9000-11583 | (3) Four-Way Conductor Holders |

Brace Clamps

- For attachment of brace pole



P/N 7160-30535 Hastings 11387
Fits 3" O.D. arm and mast assemblies

P/N 9000-11584 Hastings 13495
Fits 3.80" O.D. arm and mast assemblies and allows use of P/N 7017-02085 Brace Pole

Four Way Conductor Holder



- For mounting to 3" O.D. arm
- Opening is 1 1/2"
- Spring loaded latch is hot stick operable

P/N 9000-11583 Hastings 5034

Super Duty Conductor Holder with Latch

- For attachment to mast and jib adapters
- Features a spring-loaded release latch
- Accepts 2" diameter conductors
- Maximum working load 500 lbs.

P/N 9704-28741 Hastings EX3-726
P/N 720-30057 Replacement Cable Pin



Hot Line Tools & Accessories

HOT LINE EQUIPMENT

USA: 1-877-GO ALTEC
(1-877-462-5832)

www.alteconnect.com

Universal Tree Pruner



- Features drop forged steel blades and a two-pulley rope swing that can cut limbs up to 1 1/2" diameter
- A universal saw attachment may be used with this pruner; it is mounted on a 12" fiberglass shaft with a universal adapter and 25' of polypropylene rope

P/N 9000-01910 Hastings 10-019

Rubber Glove Auxiliary Arm

- May be added to existing auxiliary arm wireholders
- For up to 34.5 kV use



P/N 9701-05108 Hastings A30008

Shotgun Universal Tool Adapter



- Adapts shotgun sticks to all universal attachments
- Made of high-quality bronze alloy
- May be used with all major brand tools

P/N 9000-10019 Hastings A10019

Universal Disconnect Hook



- Used for opening and closing switches
- Nickel-plated steel
- Disconnect hook comes equipped with extension for hanging stick from aerial structures

P/N 9000-10044 Hastings P10431

Universal Rotary Blade (Tie Stick Head)

- Blade has self-aligning swivel action for removal of ties without looped ends

P/N 9007-10021 A10021



Fuse-Cup



- Design allows one fuse holder for 100 AMP and 200 AMP fuse barrels from any manufacturer
- Exclusive V-Guide simplifies capturing the fuse barrel for easy fuse removal and installation
- Aluminum disconnect prong is sealed and covered with the fiberglass reinforced nylon
- Fiberglass material eliminates potential hazards of flashover when removing or installing fuse tubes

P/N 9701-60288 10-094

Universal Teflon Coated Pruning Saw



- Teflon coated pruning saw
- Features a lightweight 16" curved blade for fast and easy cutting
- May be used with all poles equipped with a standard universal head

P/N 9000-11000 Hastings A11000

Universal Saw Handle



- Lightweight aluminum saw handle is for use with a universal saw when limbs can be easily reached and insulation is not needed

P/N 9000-10016 Hastings 10016

Universal Head - Splined



- Head adapts to all universal fit-on type tools for fitting to your existing sticks
- Includes cap and base

Part Number	Hastings	Diameter
9000-10017	A10017	1 1/4"
9000-10018	A10018	1 1/2"

Clamp Stick Head



- Use this head with universal sticks for installing and removing hot line clamps
- A quarter-turn of it's rotating cap locks the tool on the screw eye

P/N 9000-10022 Hastings A10022

Universal Rotary Prong with Tie Stick Head



- Prong is self-aligning, swivels freely
- Use for looped end tie wire

P/N 9007-10020 A10020

Conductor Cleaning Brushes



- All brushes have stainless steel bristles to allow the cleanest connection possible
- Stainless steel eliminates rust deterioration of bristles
- Compact "U" type brushes for tight clearances and easy storage in lineman's pouches
- Other models available

P/N 9701-00359	"U"	10-183
P/N 9700-23390	"V"	10-178

LOAD-RANGER® XLT Load Break Tool

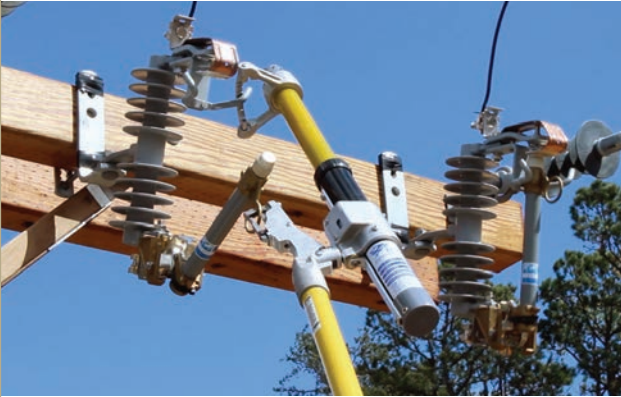

Safely open Cutouts, Disconnect Switches, Power Fuses, or any "hook equipped" device within the tools rating.

- 20% Lighter than other load break tools
- Unique Side Reset Button (easier gloved operation)
- Higher Metal-to-Metal Clearance
- Built in Counter Included
- Low profile head fits into underground cabinets and under most wildlife guards
- Interruption rating of 600 amperes nominal, 900 amperes maximum



	LOAD-RANGER® USLR-XLT-1	LOAD-RANGER® USLR-XLT-2
MAXIMUM VOLTAGE	27 kV	27 kV - 38 kV
MAXIMUM AMPERAGE	900 AMP	900 AMP
WEIGHT	4 lb 3 oz	4 lb 12 oz
METAL TO METAL CLEARANCE DURING STROKE (FLASH-OVER RESISTANCE)	8.2" EST	12.2" EST
RESET FUNCTION	SIDE LOCATION PUSH BUTTON	



Pad Mount option uses a lower profile operating arm and an extended hood for greater clearance and safety inside pad gear.

- P/N 9702-11833 USLR-XLT-1 15kV - 27kV LOAD-RANGER
- P/N 9700-98051 USLR-XLT-1-H 15kV - 27kV LOAD-RANGER w/Hard Case
- P/N 9705-45553 USLR-XLT-1-P-H 15kV - 27kV PAD MOUNT LOAD-RANGER w/Hard Case
- P/N 9000-50363 USLR-XLT-2 27kV - 38kV LOAD-RANGER
- P/N 9702-11836 USLR-XLT-2-H 27kV - 38kV LOAD-RANGER w/Hard Case



Load Break Tools

BREAK-SAFE® Load Break & Pick-up Tool

Safely create a parallel circuit. Great for new construction or maintenance. Incorporates a parking stand for use with standard jumpers.

- PATENTED
- Operates as a Portable Switch
- 300 Amp Load break, Pick-up, and Continuous Current Duty
- Floating or Duckbill Head models in 15kV, 27kV, or 46kV
- Safety Lock in OPEN or CLOSED position
- Includes Soft Carrying Case



P/N 9701-13079



P/N 9702-11843

	BREAK-SAFE® USBS-15	BREAK-SAFE® USBS-27	BREAK-SAFE® USBS-46	BREAK-SAFE® USBS-600
OPERATIONAL VOLTAGE	15 kV	27 kV	46 kV	27 kV
LOAD BREAK, LOAD PICKUP, and CONTINUOUS CURRENT RATING	300 AMP	300 AMP	200 AMP	600 AMP
CONDUCTOR SIZE	#6 COPPER MIN. up to 954 ACSR (1.1" dia.) MAX.	#6 COPPER MIN. up to 954 ACSR (1.1" dia.) MAX.	#6 COPPER MIN. up to 954 ACSR (1.1" dia.) MAX.	All sizes up to 2" dia.
WEIGHT	7 lb 1 oz	7 lb 14 oz	10 lb 1 oz	10 lb 13 oz
DIMENSIONS	27" long x approx. 2.5" dia.	31" long x approx. 2.5" dia.	39" long x approx. 2.5" dia.	32" long x approx. 3.5" dia.

- P/N 9701-13079 USBS-15-1-PS-S 15kV Rated, Gloved Operation; 300 Amps; Floating Head w/ Soft Case
- P/N 9701-07161 USBS-15-2-PS-S 15kV Rated, Stick Operation; 300 Amps; Duckbill Head w/ Soft Case
- P/N 9701-18311 USBS-27-1-PS-S 27kV Rated, Gloved Operation; 300 Amps; Floating Head w/ Soft Case
- P/N 9702-11843 USBS-27-2-PS-S 27kV Rated, Stick Operation; 300 Amps; Duckbill Head w/ Soft Case
- P/N 9702-11844 USBS-46-1-PS-S 46kV Rated, Gloved Operation; 200 Amps; Floating Head w/ Soft Case
- P/N 9702-11848 USBS-46-2-PS-S 46kV Rated, Stick Operation; 200 Amps; Duckbill Head w/ Soft Case
- P/N 9703-63719 USBS-600-1-S 27kV Rated, Gloved Operation; 600 Amps; Floating Head w/ Soft Case

Hard Case Call your Altec Representative for Hard Case Options



P/N 9703-63719

HOT LINE EQUIPMENT

USA: 1-877-GO ALTEC
(1-877-462-5832)

www.alteccconnect.com



BLUE STRIPE® Telescopic Hot Sticks

Ground Operable

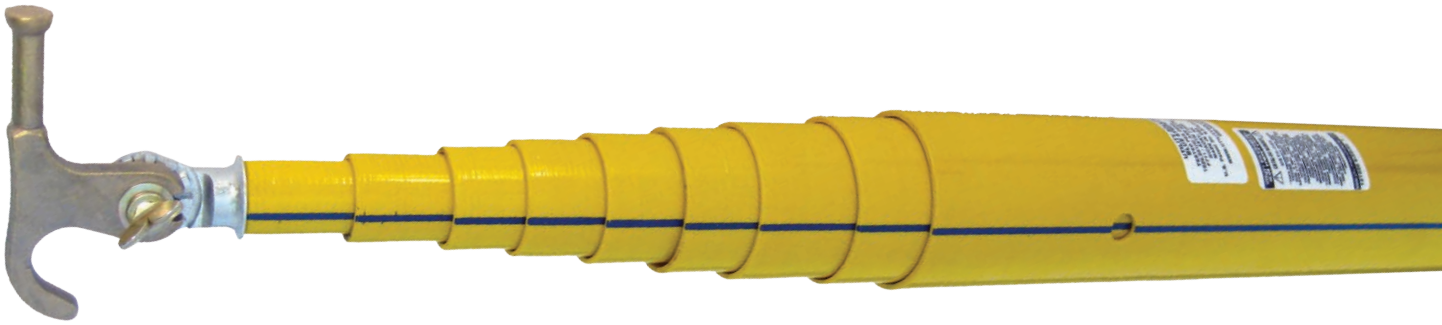

- ADVANCED COMPOSITE FIBERGLASS made from Epoxy Resin is impervious to water absorption. Sticks meet or exceed all applicable industry performance criteria, including ASTM F1826 and OSHA Sub. V sec. 1926.951(d).

- NON-WOVEN FIBERGLASS resists dirt and grime build-up better than woven construction which creates surface voids

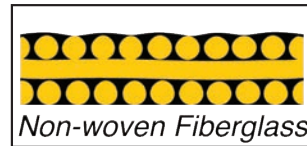

- Patented TIP LOCK BUTTON REPLACEMENT FEATURE allows button replacement without disassembling the stick
- PATENTED ALIGNMENT FEATURE allows easy button and hole alignment



- UNIVERSAL SPLINE ENDS are precision CNC machined from aircraft grade aluminum
- BUTTONS are machined (not cast) to the tightest tolerances to provide maximum shear strength
- Tip Sections are filled with high performance closed cell foam to prevent water absorption

Part Number	Utility Solutions	Size	Operating Lengths	Closed Length	Weight	Bag Part Number
9702-12034	USTS-050	50 FT.	50',45',40',35',30'	68"	20 lb	9703-35329
9702-04285	USTS-045	45 FT.	45',40',35',30',26'	66"	16 lb 8 oz	
9702-03505	USTS-040	40 FT.	40',35',30',26',21'	65"	13 lb 8 oz	
9702-12026	USTS-035	35 FT.	35',30',26',21',17'	63"	11 lb	
9702-11867	USTS-030	30 FT.	30',26',21',17'	62"	8 lb 14 oz	9703-35328
9702-11864	USTS-025	25 FT.	26',21',17'	60"	6 lb 14 oz	
9702-11863	USTS-020	20 FT.	21',17'	58"	5 lb 3 oz	
9702-11860	USTS-016	16 FT.	16',12'	56"	4 lb	



Telescopic Hot Sticks

BLUE STRIPE® Telescopic Hot Sticks

Bucket Operable

- Same Advanced Composite Fiberglass as the ground operable
- BLUE STRIPE® Patented Alignment Feature
- UNIVERSAL SPLINE ENDS are precision CNC machined from aircraft grade aluminum
- BUTTONS are machined (not cast) to the tightest tolerances to provide maximum shear strength
- Tip Sections are filled with high performance closed cell foam to prevent water absorption

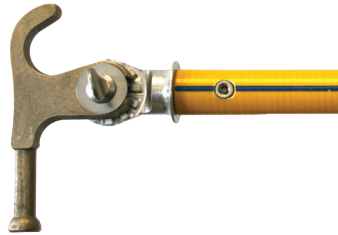

Part Number	Utility Solutions	Size	Closed Length	Weight	Bag Part Number
9702-12052	USTS-012	12 FT.	30"	5 lb 11 oz	9703-35327
9702-04285	USTS-010	10 FT.	28"	4 lb 11 oz	
9702-03505	USTS-008	8 FT.	26"	3 lb 11 oz	
9702-12026	USTS-006	6 FT.	26"	2 lb 8 oz	
9702-11867	USTS-004	4 FT.	26"	2 lb	

Measuring Telescopic Hot Stick



- Fully Rated Hot Stick with all the BLUE STRIPE™ Features
- English or Metric
- One Stick - Dual Function

ENGLISH		METRIC		SIZE	CLOSED LENGTH	WEIGHT	Bag Part Number
Part Number	Utility Solutions	Part Number	Utility Solutions				
9705-45554	USTS-050-EM	9705-45562	USTS-050-MM	50 ft. 15.2 m	68"	20 lb	9703-35329
9705-45555	USTS-045-EM	9705-45563	USTS-045-MM	45 ft. 13.7 m	66"	16 lb 8 oz	
9705-45556	USTS-040-EM	9705-45564	USTS-040-MM	40 ft. 12.2 m	65"	13 lb 8 oz	
9705-45557	USTS-035-EM	9705-45565	USTS-035-MM	35 ft. 10.6 m	63"	11 lb	
9705-45558	USTS-030-EM	9705-45566	USTS-030-MM	30 ft. 9.1 m	62"	8 lb 14 oz	
9705-45559	USTS-025-EM	9705-45567	USTS-025-MM	25 ft. 7.6 m	60"	6 lb 14 oz	9703-35328
9705-45560	USTS-020-EM	9705-45568	USTS-020-MM	20 ft. 6.2 m	58"	5 lb 3 oz	
9705-45561	USTS-016-EM	9705-45569	USTS-016-MM	16 ft. 4.9 m	56"	4 lb	

HOT LINE EQUIPMENT

USA: 1-877-GO ALTEC
(1-877-462-5832)

www.alteccconnect.com

BLUE STRIPE® Shotgun Sticks



Every Utility Solutions shotgun stick is manufactured from the highest electrical grade insulated fiberglass and meet or exceed all applicable industry performance criteria including ASTM F711, IEC 855, and OSHA Sub. R Section 1910.269 (J) and OSHA Sub. V Section 1926.951(d).

- Replaceable shotgun hanger hooks
- When the patented BLUE STRIPE® is positioned facing upward the stainless steel hook will open downward
- The operating hook is stainless steel for maximum strength
- Multiple rod guides ensure smooth operation
- External rod shotgun sticks are filled with high performance closed cell foam to prevent water absorption
- Universal spline ends are precision CNC machined from aircraft grade aluminum



Need extra turning force?
The 18" Torque Bar attaches to any standard spline end.

P/N 9703-35336 USSA-STB-018 Spline Torque Bar



Part Number	Utility Solutions	Size	Description	Weight	Bag Part Number
9703-35300	USSG-004-EREC	4' 6"	External Rod with End Cap	4 lb 4 oz	9703-35328
9703-35302	USSG-006-EREC	6' 6"		5 lb 6 oz	9703-35330
9703-35303	USSG-008-EREC	8' 6"		6 lb 3 oz	9703-35331
9703-35304	USSG-010-EREC	10' 6"		7 lb 5 oz	9703-35332
9703-35305	USSG-004-ERSE	4' 6"	External Rod with Spline End	4 lb 4 oz	9703-35328
9703-35306	USSG-006-ERSE	6' 6"		5 lb 6 oz	9703-35330
9703-35307	USSG-008-ERSE	8' 6"		6 lb 3 oz	9703-35331
9703-35308	USSG-010-ERSE	10' 6"		7 lb 5 oz	9703-35332
9703-35309	USSG-004-IREC	4' 6"	Internal Rod with End Cap	4 lb 4 oz	9703-35328
9703-35310	USSG-006-IREC	6' 6"		5 lb 3 oz	9703-35330
9703-35311	USSG-008-IREC	8' 6"		5 lb 14 oz	9703-35331
9703-35312	USSG-010-IREC	10' 6"		6 lb 13 oz	9703-35332
9703-35313	USSG-004-IRSE	4' 6"	Internal Rod with Spline End	4 lb 4 oz	9703-35328
9703-35314	USSG-006-IRSE	6' 6"		5 lb 3 oz	9703-35330
9703-35315	USSG-008-IRSE	8' 6"		5 lb 14 oz	9703-35331
9703-35316	USSG-010-IRSE	10' 6"		6 lb 13 oz	9703-35332

Shotgun & Straight Sticks

BLUE STRIPE® Foam Filled Straight Sticks

Utility Solutions straight sticks meet or exceed all applicable industry performance criteria including ASTM F711, ASTM F1826 and OSHA Sub. V sec. 1926.951(d).

- Heavy Duty Rubber End Cap
- 1 1/4" diameter high quality electrical grade fiberglass
- Wall thickness has been engineered to handle the toughest pushing, pulling and twisting
- Filled with high performance closed cell foam to prevent water absorption
- Chemically sealed finish with a smooth textured surface for easy cleaning



Universal Spline End

9703-35318	USSS-004-SE/EC	4'
9703-35319	USSS-006-SE/EC	6'
9703-35320	USSS-008-SE/EC	8'
9703-35321	USSS-010-SE/EC	10'

NEMA Switchhead

9703-35322	USSS-004-SH/EC	4'
9703-35323	USSS-006-SH/EC	6'
9703-35324	USSS-008-SH/EC	8'
9703-35325	USSS-010-SH/EC	10'

Hot Stick Accessories



P/N 9705-45570	USSA-HGR	Plastisol Hanger and Clamp
P/N 9703-35337	USSA-ASD	Ice Wacker
P/N 9705-45571	USSA-MSC	Shoe String Cutter
P/N 9705-45572	USSA-OHP	Universal Hotstick Probe
P/N 9705-45573	USSA-ORB	Rotary Blade Spline Attachment
P/N 9705-45574	USSA-ORP	Rotary Prong Spline Attachment

Fiberglass Care and Maintenance

- Stay OSHA compliant and extend the life of your hot stick
- *Cleaner ships EMPTY to save freight, includes concentrated tablet
- Wipes come in a convenient dispenser box



Part Number	Utility Solutions	Description	Size
9705-45575	USTS-CLEANER	BLUE STRIPE® General Purpose Cleaner	1 US Gallon*
9705-45576	USTS-SILCLOTH	BLUE STRIPE® Microfiber Silicone Hot Stick Cloth	18" x 18"
9705-45577	USTS-SILWIPE	BLUE STRIPE® Daily Hot Stick Wipes (50 per box)	8" x 12"
9705-45578	USTS-WAX	BLUE STRIPE® High Grade Carnuba Wax	14 oz.

HOT LINE EQUIPMENT

USA: 1-877-GO ALTEC
(1-877-462-5832)

www.alteccconnect.com

Jack Jumper™ Cutout Bypass Tool



The Jack Jumper™ Cutout Bypass Tool permits a safe and quick method to temporarily bypass an overhead cutout without jumper cables.

- **PATENTED Lineman Idea!**
- Install and remove with a shotgun stick
- Rated at 100 Amps
- Fuse coordination tasks
- Bypass an underground dip
- Saves time and money
- Eliminates service interruption
- Prevents accidental cross phasing



images NOT to scale

9702-08572	USJJ-001S	15 kV Cutout Bypass Tool with Soft Case
9701-29495	USJJ-002S	27 kV Cutout Bypass Tool with Soft Case
9705-45579	USJJ-003S	15 kV Chance™ Load break Cutout Bypass Tool with Soft Case
9702-01065	USJJ-004	15 kV ABB™ Load break Cutout Bypass Tool
9702-01067	USJJ-005	38 kV Cutout & S&C™ SMD-20 15 kV Power Fuse Bypass Tool
9705-45580	USJJ-006	S&C™ SMD-20 27 kV Power Fuse Bypass Tool
9702-08575	USJJ-007	S&C™ SMD-20 38 kV Power Fuse Bypass Tool
9705-45581	USJJ-008	27 kV Chance™ Load break Cutout Bypass Tool
9705-45582	USJJ-009	27 kV ABB™ Load break Cutout Bypass Tool

Fuse-Safe™ Portable Protection

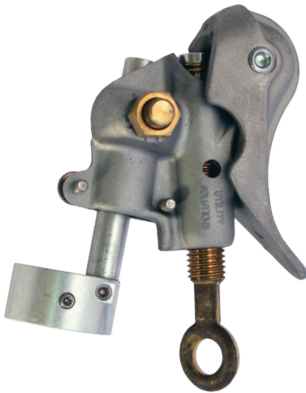

The Fuse-Safe™ is a portable current-limiting fuse and fault close-in protection tool.

- Works as Safety Fuse when placed in series with the Utility Solutions BREAK-SAFE®
- Will not expel hot metal or gases when triggered
- Best choice for Fire prevention areas

The Fuse-Safe™ consists of two components: an upper duckbill coupling ring and a lower conductor bar coupling ring. These components attach to any 5/8" studded end current limiting fuse using a standard 1/8" Allen wrench (provided).

Does Not include a fuse.



9702-08576 USFS-001 Fuse Safe™ 5/8" Conductor Bar Without Fuse



Overhead Tools

Grab-It™ Cutout Fuse Tube Remover



The Grab-It™ offers a simple and safe method to remove or install overhead fuse barrels.

- **PATENTED Lineman Idea!**
- No more hunting for pull ring or lifting eye
- Easily capture fuse barrel in any condition (wind, low light, far away)
- Keeps positive control of the fuse barrel during installation and removal

Simply sweep behind the fuse barrel and lift. The Grab-It™ is machined from aircraft grade aluminum and has NO MOVING parts or plastics.

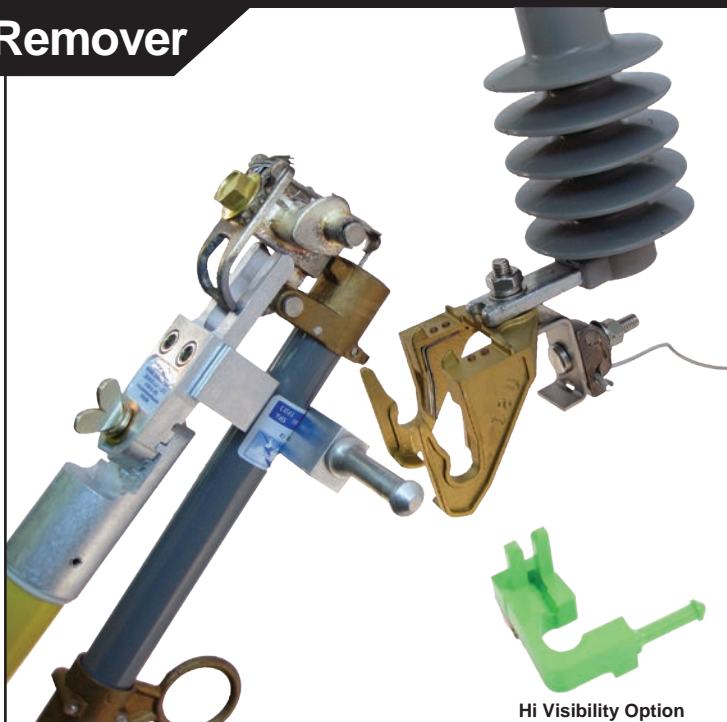

Hi Visibility Option

Part Number	Utility Solutions	Description	Size
9701-27524	GRAB-IT-1	100 AMP Fuse Tube	4.5" x 4.5" x 4"
9705-45584	GRAB -IT-1F	100 AMP Fuse Tube with Hi Visibility Coating	4.5" x 4.5" x 4"
9702-84500	GRAB-IT-2	100 & 200 AMP Fuse Tube	4.5" x 4.5" x 4"
9703-35339	GRAB-IT-3	SMU-20 Fuse Tube	6" x 4.5" x 4"

Conductor Cleaning



The Utility Solutions Conductor Cleaner Clamps and Brushes offer a stick operated alternative to hand held conductor cleaners.

- Shotgun Stick Operated
- Provides full 360 degree conductor cleaning
- Economical replacement brush pad sets available

#4 to 750 MCM, and 3/4" up to 11" conductor sizes



Part Number	Utility Solutions	Description	Conductor Size
9705-45585	USCC-001	Conductor Cleaning Clamp	#4 - 750 MCM
9705-45586	USCC-002	Replacement Brush Set	250 MCM - 750 MCM
9705-45587	USCC-003	Replacement Brush Set	#4 - 250 MCM
9703-35351	USCC-004	Conductor Cleaning Brush	3" - 11"
9703-35352	USCC-006	Conductor Cleaning Brush	3/4" - 3"
9703-35353	USCC-005	Replacement Brush Set	3" - 11"
9703-35354	USCC-007	Replacement Brush Set	3/4" - 3"



UTILITY SOLUTIONS

Lineman driven. Field proven.®

Overhead Products

HOT LINE EQUIPMENT

Jumper Cable Accessories

Jumper-T

Eliminate extra long jumper cables by combining shorter sections with the Insulated Jumper-T. Meets or exceeds all applicable industry performance criteria including OSHA 1926.951(d)(1) and ASTM F-711.

- Creates a visible gap when used with the BREAK-SAFE®
- Non-conductive foam filled fiberglass provides over 15" of metal-to-metal clearance
- Duckbill clamp will fit #6 copper up to 1033 MCM
- Rated for 400 Amperes Continuous Current
- USJT-002 uses bent parking stand which minimizes sag and cross-phasing potential

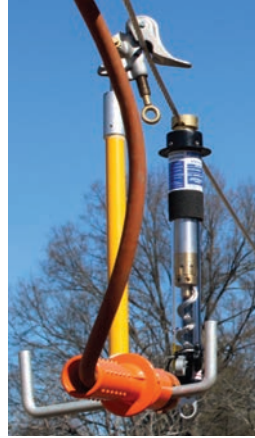

- 9705-45588 USJT-001 5/8" Diameter, Straight Bar, 26.5" Jumper-T
- 9705-45589 USJT-002 3/4" Diameter, Bent Bar, 26.5" Jumper-T

Jumper Hook

Designed to eliminate jumper sag and prevent potential cross-phasing, the Jumper Hook is made from a strong, high visibility polymer.

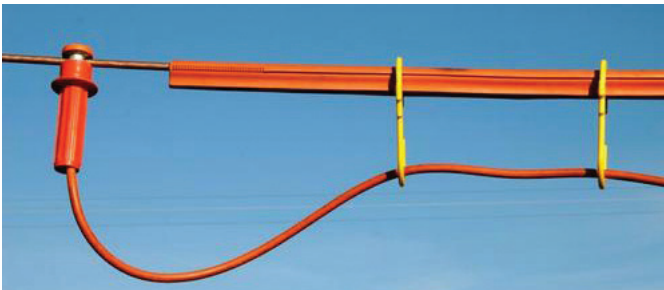

- No more tape, bungee cords or rope
- Minimizes sag, swaying, and potential cross-phasing
- Installs by gloved hand or with a shotgun stick
- Fits over any class 2 or 3 line hose
- Flash-over resistance of over 50 kV



- 9702-08582 USJH-001 Jumper Hook (6 per pack)

Wildlife Protection

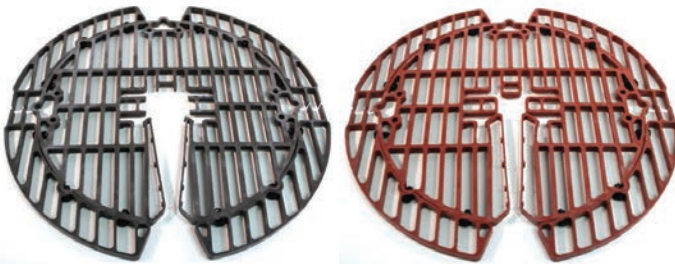

- 9702-38385 USVS-001 16" VARMINT SHIELD - GRAY
- 9705-45591 USVS-002 16" VARMINT SHIELD - RED
- 9705-45592 USVS-003 20" VARMINT SHIELD - GRAY
- 9705-45593 USVS-004 20" VARMINT SHIELD - RED

Varmint Shield

The Varmint Shield prevents critters from simultaneously touching the primary and metal case of a transformer. The varmint shield can also be installed on substation insulators and bushings.

- Installs with a shotgun stick on energized equipment
- Molded from a UV stabilized and flame retardant (UL 94 V-0) polymer
- Will not trap or accumulate leaves
- Fits 1.75" to 6" diameter equipment



USA: 1-877-GO ALTEC
(1-877-462-5832)

www.alteconnect.com



Meter Products

Meter Grabber

The Utility Solutions Meter Grabber is an indispensable tool for electric meter installation, removal or change-outs. The Meter Grabber provides superior protection from exploding meters due to faults.

- No metal components on working end
- Side slots permit venting during a fault
- Provides a positive capture around the entire base
- Additional mechanical leverage when removing stubborn meters



Part Number	Utility Solutions	Description	Bag Part Number
9702-11852	USMG-001	Meter Grabber	9702-11858
9702-11854	USMG-002	Meter Grabber with Arc Shield	9705-45594

Electric Meter Jumper Leads



Electric Meter Jumper Lead sets are a convenient and safe method to prevent a customer outage during meter removal or change-out.

- Constructed from #6 AWG highly flexible insulated copper
- Ferrule ends machined of solid copper
- Attaches over the bypass horn
- Available with 100 AMP, single pole, 240 volt hydraulic breaker



9702-08579	USJL-001	Pair of Jumper Leads
9702-08581	USJL-002	Pair of Jumper Leads with 100 AMP Breakers

HOT LINE EQUIPMENT

USA: 1-877-GO ALTEC
(1-877-462-5832)

www.alteccconnect.com

Install & Remove Electric Meters Safely!

METERPULLER — The **MeterPuller**® makes the utility operating personnel's job easier, safer and faster when removing and installing electric meters. It works on virtually any residential, commercial and industrial electric meters that plug into a ring or ring-less type meter socket. It is made of lightweight, high strength polycarbonate with chrome plated steel clips.

- 9701-84714** M-001, Residential Single-Phase Meters, Transparent Amber
- 9701-84715** M-002A, Residential Single-Phase and Commercial & Industrial Poly-Phase Meters, Transparent Orange
- 9701-84718** M-009, Canvas Storage Bag for Single M-001 or M-002A



M-009



M-001



M-002A

RUP HOLDTAG — The Rauckman Utility Products Tagging Device R-TD is specifically designed for electric utility applications. Molded from a specially blended elastomer the R-TD remains functional during the most frigid or sweltering weather. In addition to its non-tracking properties the R-TD has a UL-94 flame retardant classification of V-0. Ultra-violet stabilizers ensure that the R-TD lasts for many years of service..

- 9701-84719** R-TD Tagging Device, Orange, 4.4 oz.
- 9701-84720** R-TD2 Tagging Device with Clip, Orange, 4.5 oz.



R-TD2

R-TD



R-TD field shaping of hooks

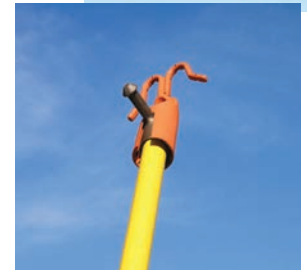

Designed to allow the use of a disconnect (switch) stick to aid in installation and removal.



200A Clamp-on Bushing Installation Tools

- Preset torque limiter takes guesswork out of bushing installation
- Can be used for bushing removal



P/N 9000-00525 BIT/TK120X-Q

Bushing Insert with Quick Clamp and 130 in-lb. torque limiter (fits all loadbreak bushing inserts)

P/N 9706-37342 BIT/TK120X-N

Bushing Insert Tool with 130 in-lb torque limiter (fits all deadbreak bushing inserts) (for use on non-loadbreak bushings only)

P/N 9000-00526 FIT/TK120X

Feedthru Insert Tool with 120 in-lb torque limiter (fits all loadbreak feedthru inserts)

P/N 9700-84338 RK-1

Regrit Kit for abrasive surface

200A Loadbreak Bushing Installation Tool

- The BIT/E180 Series Bushing Insert Tool provides preset torque for installation and removal of bushing inserts with a 5/16" internal hex socket. Available in both T-Handle (AT) and OP eye (AH) versions
- 180 in-lb. torque limiter

P/N 9700-73103 BIT/E180AT

Features T-handle - 5/16" hex shaft

P/N 9706-37343 BIT/E180AH

Features Operating Eye - 5/16" hex shaft (same as Elastimold 200AT and Cooper LB 1)

P/N 9700-73103 (Left)
BIT/E180AH (Right)

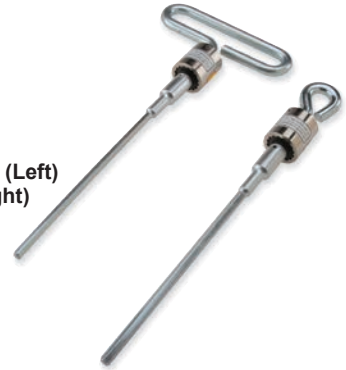

15/25kV Probe Installation Tools

The LPW1525/TK120X is designed to provide a means of preventing probe arc follower contamination and other damage when installing 15kV, 25kV and Elastimold 35kV probes. The tool holds the loadbreak probe for positioning into the threaded eye of the elbow crimp connector. The 120 in-lb torque limiter clicks to indicate that the proper installation torque has been reached. The LPW1525/TK120X-N version adds a v-groove and cross hole in the wrench body to provide neutral winding capability for removing the outer jacket.

Features:

- Prevents elbow probe arc follower contamination and breakage
- Preset torque limiter takes guesswork out of elbow probe/connector tightening
- Neutral Winder option reduces neutral wire breakage while removing cable jacket
- Fits all 15kV and 25kV elbows and Elastimold 35kV elbows

P/N 9000-15251 LPW1525/TK120X-N

Loadbreak Probe Wrench with neutral winder and 120 in-lb. torque limiter

P/N 9706-37344 LPW1525/TK120X

Loadbreak Probe Wrench with 120 in-lb. torque limiter

P/N 9703-47280 LPW1525

Probe Wrench for use with 1/4" square drive (not shown)

P/N 9706-37345 TK120

Torque Limiter with 1/4" square drive (not shown)



15/25kV Elbow and Cap Pulling Tool

- Fits all 15kV, 25kV and Elastimold 35kV elbows and caps
- For use in removing seized elbows and protective caps
- Lever action provides significant mechanical advantage
- Fits standard shotgun stick as an accessory
- Ergonomically friendly
- Includes high dielectric pulling rope and carrying bag

P/N 9706-37346 PT-1525 Elbow/Cap Pulling Tool



HOT LINE EQUIPMENT

USA: 1-877-GO ALTEC
(1-877-462-5832)

www.alteconnect.com



Deviner™

The DEVINER™, a vine removal utility tool that offers a quick and efficient way to safely remove vines and other vegetation away from power lines. Vines and other vegetation can cause serious power outages and service interruptions.

Features & Benefits

- Fiberglass reinforced nylon for maximum strength and safety
- Aluminum base for a strong secure fit
- Lightweight, non-conductive and corrosion resistant
- Fits ALL universal tool fittings found on hot sticks

Also good for:

- Hooking tag lines
- Breaking ice
- Removing tree limbs
- Clearing vegetation at the pole base of a transmission tower
- Fishing down wires from trees
- Removing vacant bird nest debris

P/N 9705-84822 DV-1



DOUBLE-HEADER™
Universal Attachment

Double-Header™

The DOUBLE-HEADER™ Universal Attachment tool is a unique tool that linemen can use on the end of an extendo or insulated switch stick. It allows the use of two different tools on one stick.

- Allows you to attach 2 different universal tool accessories to maximize speed and convenience
- Includes 2 thumb screws

2 Heads Are Better Than 1

P/N 9705-84823 DH-1

Tri-Penta™ Wrench

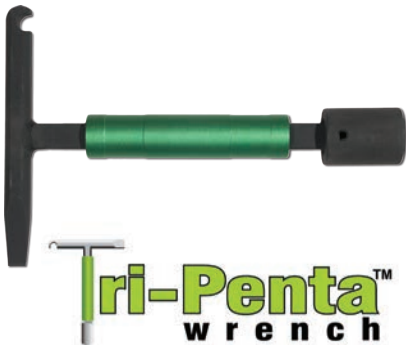

The Tri-Penta Wrench™ underground utility wrench combines three everyday functions into one convenient tool. The PentaSocket opens transformers and switch gears. The addition of a high visibility patent pending Speed Sleeve™ helps linemen open transformers and switch gears up to 2X faster than standard penta sockets or wrenches. It also comes with 2 other tools built into the handle.

Features & Benefits

- 3/4" removable Penta Socket
- Speed Sleeve™ opens 2x faster
- Integrated Lid Lifter for hand hole lids
- 3/8" Screwdriver for opening secondary or primary doors

Featuring Speed Sleeve™ - Up to 2X Faster Turns

P/N 9705-84824 TP-1

Penta Socket Driver™

The Penta Socket Driver™ can be utilized in any 1/2" drive hand tool, any 3/8" or 1/2" drill drivers and impact wrenches. This tool is perfect when space is limited and the tough angle calls for a ratcheting wrench or even an impact wrench.

Features & Benefits

- 3/4" Penta Socket impact rated for torque
- Speed Sleeve™ helps stabilize the operation and keeps your hand or gloves from experiencing any twisting or friction
- 3/8" drill adapter is removable

Featuring Speed Sleeve™ - Provides Stability and Eliminates Friction

P/N 9705-84825 PSD-1



PENTA SOCKET DRIVER™
Featuring Speed Sleeve



BrushBlade™ “The Lineman’s Knife”

BrushBlade™ combines 2 tools into one; a knife and an integrated wire brush. Not only is it more efficient but it is significantly safer than knives currently available.

Features & Benefits

- 2 Tools in 1 – maximize safety and productivity
- Integrated wire brush for cleaning conductors to make better connections
- Brushes up to 1000 MCM Conductor
- Wire brush is easily replaceable
- Stainless steel blade for maximum durability and sharpness
- Locks in open position to prevent accidental closing
- Blade can be closed when not in use

Maximum Safety and Productivity

- P/N 9706-37555 BB-1 BrushBlade Lineman’s Knife
 P/N 9705-84827 WB-1 Wire Brush Replacement (for BB-1)



BrushBlade™
THE LINEMAN’S KNIFE

MADI Pocket Knife

The MADI Pocket Knife is a super compact multi-purpose knife.

Features & Benefits

- Stainless steel blade for maximum durability and sharpness
- Durable aluminum handle
- Integrated strap cutter, wire stripper and glass breaker
- Includes removable belt clip
- Overall length 6.2” (15.3 cm), length closed 3.66” (9.3 cm)

- P/N 9706-37556 PK-1 MADI Pocket Knife



Maximum Convenience

DogBone™ Wire Brush



The DogBone™ Wire Brush has two designated brushing surfaces, one side for copper and the other side for aluminum. The ends are color coordinated to allow linemen to keep one tool with dedicated brushing ends for two different surfaces.

Features & Benefits

- 2 brushes in 1 tool
- One for Copper and one for Aluminum (up to 1590 MCM)
- Durable and made of non-conductive material
- Lightweight – weighs less than ½ pound
- Wire brushes are easily replaceable
- Integrated brush design eliminates lineman hand and leg discomfort currently experienced with other wire brushes
- Built-in snap ring makes it easy to store on belts or in bucket trucks

Make Better Connections

- P/N 9705-84828 DBWB-1 DogBone™ Wire Brush
 P/N 9705-84830 LWB-1 Wire Brush Replacement



FlatRound™ Wire Brush

The FlatRound™ has two designed brushing surfaces, one side for flat connections and the other for round connections. The flat wire brush can be used on any flat surface, such as flat pads on the pad-mounted transformer, hylugs and all cable to flat connectors. In Transmission applications, the flat side can also be used on all dead-end single-tongue and jumper-terminal connectors. In Substation applications it can be used on all terminal connections.

Features & Benefits

- 2 different brushes in 1 tool - Flat and Round (up to 1590 MCM)
- Durable and made of non-conductive material
- Lightweight – weighs less than ½ pound
- Wire brushes are easily replaceable
- Integrated brush design eliminates lineman hand and leg discomfort currently experienced with other wire brushes
- Built-in snap ring makes it easy to store on belts or in bucket trucks

Make Better Connections

- P/N 9705-84829 FRWB-1 FlatRound™ Wire Brush
 P/N 9705-84830 LWB-1 Wire Brush Replacement



HOT LINE TOOLS & ACCESSORIES

Aluminum Sheave Head with (2) 4" Sheaves



- Includes (2) P/N 415-20062 4" Sheaves, (2) P/N 235-45012 3/4" x 3" ball lock pins, (1) P/N 235-45011 3/4" x 4 3/4" ball lock pin, and (1) P/N 720-30055 3" sheave head weldment
- Can be used in conjunction with material handler
- Dual sheave

P/N 720-30056

Wireholder Assembly

- Chance Model Wireholder attached to custom, Altec Exclusive wireholder adapter
- Accommodates conductors up to and including 1.5" diameter opening
- Gate is held closed by a springloaded latch which must be manually opened
- Seven Delrin plastic rollers offer protection to conductors while raising the conductor above the work area
- 800 lb. capacity

P/N 9701-65365



Aluminum Sheave Head for 4" Square Jib



- Includes (2) P/N 415-20062 4" Sheaves, (2) P/N 235-45012 3/4" x 3" ball lock pins, (1) P/N 235-45018 ball lock pin, and (1) P/N 720-30208 sheave head
- Overcenter dual sheave

P/N 9701-94253 Kit

35kV Loadbuster



- Brings load switching capability through 34.5 kV and 600 amperes nominal, 900 amperes maximum to your overhead distribution system
- Gives the operating flexibility of a system with multipoint interrupter switches but without the cost
- Able to break the associated transformer magnetizing currents, line-charging currents, and cable charging currents

- Can switch single capacitor banks typically found on distribution systems within its voltage rating
- 50/60 hertz interrupting rating of 600 amperes nominal, 900 amperes maximum

P/N 9700-05649 5300R3 14.4/25 kV Nominal, 27kV Maximum

P/N 9700-89151 5400R3 25/34.5 kV Nominal, 38kV Maximum

P/N 9700-05650 Carrying Case for P/N 9700-05649



3" Round Jib Adapter Tube, TA Series Jib to Hastings Tool

- 11.5" Long x 3" Diameter
- Steel with .25" wall

P/N 720-30267

Talon Fuse Handling Fitting



- Two-pronged aluminum/bronze fitting designed for installing and removing power fuses, fuse cutouts, and fuse limiters from their mountings on overhead distribution systems
- May also be used to open and close disconnects and interrupter switches

P/N 9701-00577

Blanket Clamp



- Holds insulating blankets and cover ups securely
- Blanket pin opens to a full 5 1/2"
- Features springs for resistance, tapered ends, and molded rubber tips
- Excellent slip resistance

P/N 9701-34816

Underwater Kinetics LitLink



- By connecting it with any hot stick tool, the LitLink's high intensity LED provides lighting for work in dark or dimly lit areas
- Fits all major hot sticks and tools with splined universal slotted connector
- Weighs only 7 oz.
- Works with most universal tool accessories

P/N 9700-59056

Underwater Kinetics LitFinger



- For hot stick operations in dark or unlit areas
- Increases visibility, making work on fuse barrels, cutouts, switches and disconnects safer and more efficient
- Lightweight, durable, virtually indestructible, even in extreme temperatures and conditions

P/N 9000-96192

Insulated Rubber Blankets

Utility Solutions blankets meet or exceed all applicable ASTM D-1048 performance criteria. All blankets are Type II, manufactured from EDPM to provide maximum resistance to ozone damage.

- EVERY blanket is tested and date stamped prior to shipping
- Style A and free from any internal reinforcement for maximum flexibility
- High visibility yellow color

P/N 9705-45600 USRB-36-6-SLD 36" x 36", Slotted Insulated Blanket, 8lb 4oz
 P/N 9705-45601 USRB-36-28-SLT 36" x 36", Slotted Insulated Blanket, 8lb 4oz
 P/N 9705-45602 USRB-22-28-SLT 22" x 22", Slotted Insulated Blanket, 2lb 8oz

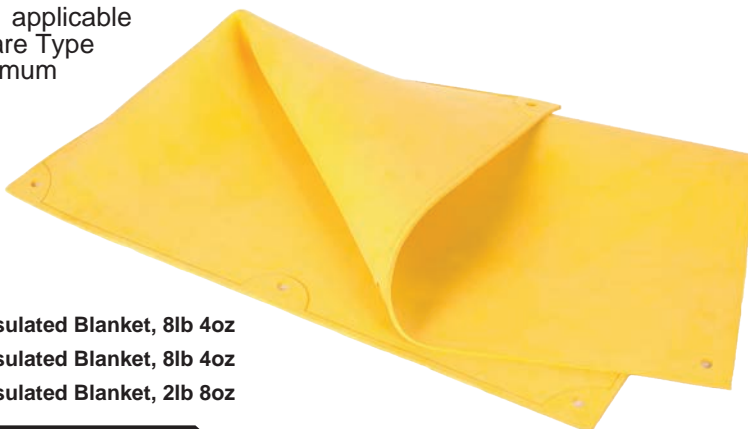

Jumper-Aid™



The patented Jumper-Aid™ supports a mechanical jumper and an insulating rubber blanket. It is particularly useful when a jumper is required to be in the vicinity of a conductor of a different voltage/phase. It can also hang securely on a cross arm and support well over 100lbs.



14" x 10" x 1", 1 lb 3 oz.

- High visibility polymer
- Pivoting action

P/N 9705-48416 USJH-002 Jumper Hook (6 per pack)



Klondike Clamps & Pins



P/N 9701-07168 USCP-001 Klondike Clamp, 7"- 11" Diameter Range
 P/N 9702-08590 USCP-002 Klondike Clamp, 11"- 20" Diameter Range



P/N 9705-45604 USBA-001 Blanket Clamp
 P/N 9705-45605 USBA-002 Blanket Clamp - Stick Operable

Blanket Mate Heavy Duty Blanket Holder

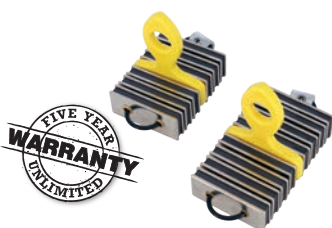

Tear drop shaped ends easily slide through the molded holes on a blanket. The strong, nearly indestructible Blanket Mate protects both equipment and blankets.

P/N 9703-35344 USBM-001 6 Magnet Holder
 P/N 9703-35345 USBM-002 8 Magnet Holder

RUBBER GOODS
& COVER-UPS

USA: 1-877-GO ALTEC
(1-877-462-5832)

www.alteccconnect.com

RUBBER INSULATING COVERS

**RUBBER GOODS
& COVER-UPS**

**USA: 1-877-GO ALTEC
(1-877-462-5832)**

www.alteconnect.com

36" x 36" Rubber Insulating Blankets Clamp Pins



- Class 4 (highest rating in the industry)
- Will retain its high visibility orange color
- May be used in applications which require a lower class or type

- Type II ozone/corona-resistant elastomer offers excellent performance properties in accordance with ASTM Standard Specification D-1048
- Offers superior resistance to long-term aging/checking

P/N 9000-00346 C4060346 Solid Blanket 6 eyelets
P/N 9700-40588 C4060348 Slotted Blanket 28 eyelets

Rubber Blanket Buttons



- Sold individually
 - For use with any rubber insulating blanket with perimeter eyelets
- P/N 9700-40591 C4060532

Deadend Cover



- These covers provide a highly versatile system of covering up a wide variety of configurations on distribution systems

- The conductor covers couple with the insulator units and deadend units to cover pin-type or post-type insulator construction, virtually surrounding the hot parts and hardware to give lineworkers extra protection when rubber gloving or using hot sticks
- Each item is fitted with an adapter for multi-position handling by Grip-All clampsticks
- Covers couple with Chance 25 kV covers, Classes 2, 3, and 4 of rubber line hose and major brands of rubber insulator hoods
- All covers are bright orange in color
- All are made of high density polyethylene in a uniform wall thickness for excellent dielectric/puncture strength
- Perform well from -50° to 170°F
- Ultra-violet stabilizers in the material help inhibit degradation as a result of atmospheric exposure.
- Deadend cover fits three 10" diameter porcelain bells or polymer deadend insulators and couples with the line cover
- To meet the Class 4 rating, the deadend cover must be used in conjunction with a rubber insulating blanket covering the coupler to the line cover
- Failure to use a blanket to cover the coupler may result in electrical shock, severe injury or death by electrocution

P/N 9700-71636 C4060537 36 kV Phase-to-Phase



- P/N 9700-40137 features eyes and special handle shape for easy placement by clampstick
- P/N 9000-00531 features a special handle shape for easy placement by clampstick

P/N 9700-40137 C4060530 Rubber Glove Use
P/N 9000-00531 C4060531 Hot Stick Use

Straight Line Hose



- Does not absorb water
- Type II ozone/corona-resistant elastomer offers excellent performance properties in accordance with ASTM Standard Specification D-1050-90

P/N 9000-40629 C4060296 Class 2, 1.25" diameter, 6' Length, 4.55 lb.
P/N 9000-40602 C4060299 Class 3, 1.5" diameter, 6' Length, 6.22 lb.

Short-Lip Flexible Line Hose



- Does not absorb water
- Type II ozone/corona-resistant elastomer offers excellent

performance properties in accordance with ASTM Standard Specification D-1050-90

P/N 9700-16341 C4060306 Class 2, 1.25" Diameter, 6' long Coupler on One End; Proof Tested at 20kV AC RMS

P/N 9000-60309 C4060309 Class 3, 1.5" Diameter, 6' long Coupler on One End; Proof Tested at 30kV AC rms

Spiral Conductor Cover

- Provides extra protection with a wide air space between two thicknesses of solid insulation
- Made of tough, durable ABS plastic
- Overall length of each cover is 53"
- A 4' or 6' long retractable Epoxiglas® handle or Clampstick adapter provides for ease of installation from a bucket or platform, in single units or linked together
- All units interlock with each other to make up a chain of guards
- 15/36.6 kV units are formed on the ends to fit over most 15kV insulators, thus eliminating the need for an insulator cover
- Each double-crossarm unit will fit over two 15kV pin-type insulators



P/N 9007-40600 C4060082GA 46 kV Phase-to-Phase

Please contact 1-877-GO ALTEC (1-877-462-5832) for additional information regarding Chance products.

RUBBER INSULATING COVERS

Pole Covers



- Prolonged contact with an energized conductor must not be allowed
- Tested to ASTM F712
- Manufactured to ASTM F968 specifications
- Meet Class 4 requirements
- Made of high dielectric linear polyethylene material that will not flash flame
- Helps protect personnel when raising or lowering a pole between energized lines or to cover poles when rubber glove maintenance is performed in relatively confined areas
- This material will have some softening without deformation at approximately 170°F, and it will resist brittleness at temperatures to -50°F
- Chance covers are ribbed to reduce cover contact with the pole, thus minimizing creosote contamination
- Rope handles permit personnel to easily spread the covers and snap them around the pole; rubber gloves must be worn during this procedure

6" Diameter Pole Covers

9700-40577 C4060550 48" long
9700-40579 C4060551 72" long

9" Diameter Pole Covers

9700-40580 M4937-1 12" long
9700-40582 M4937-2 24" long
9703-23921 M4937-4 48" long
9700-40584 M4937-6 72" long

12" Diameter Pole Covers

9700-40586 C4060029 24" long
9000-04030 C4060030 48" long
9000-40600 C4060000 72" long

Conductor Cover & Insulator Covers



- Bright orange in color
- 5' long; 25 kV phase-to-phase
- Maximum conductor size: 666 kcmil ACSR
- Perform well from -50° to 170°F
- Available with adapter for hot stick application or without adapter for rubber glove application
- Provide a highly versatile system of covering up a wide

variety of configurations on distribution systems; the units virtually surround the hot parts and hardware to give the linemen extra protection when rubber gloving or using hot sticks

- Made of high density polyethylene in a uniform wall thickness for excellent dielectric/puncture strength
- 5' long and are available with a Grip-All adapter for hot stick application or without adapter for rubber glove application
- Conductor covers mate with insulator covers to cover pin-type or post-type insulator construction; may also be used with the deadend cover
- Conductor cover will couple with major brands of rubber line hose and insulator covers of the 25kV class

25 kV Phase-to-Phase:

P/N 9000-40601 C4060181
P/N 9700-40972* C4060181GA
P/N 9700-55622 P4060184

5' Cover; 4' Handle
5' Cover; Grip-All Adapter
5' Cover Only

36 kV Phase-to-Phase

P/N 9700-22458* C4060514GA 5' Cover; Grip-All Adapter

*Features an adapter

Overhead Switch Barrier

- The Overhead switch barrier is used as a physical cover for 12kV or 15kV horizontal 3-phase switches in substations, allowing work to be performed on the underside of the switch.



P/N 9706-02757 PSC4060648 Barrier Board
P/N 9706-02756 PSC4060651 Barrier Board Kit (2 barriers and bag)
P/N 9706-02755 PSC4060650 Bag

Cross Arm Cover



- Prevents tie wires from contacting the crossarm when tying and untying insulators
- The material used is the same high-dielectric polyethylene used for Chance conductor and insulator covers
- Flanges above the slots shield the ends of the double-arming bolts
- Designed for single or double arm construction, with slots provided for double-arming bolts

P/N 9700-53679 M4933

Insulator Covers



- Insulator covers come in two heights: 12" or 16.5"
- Cover fits 6.5" to 9" diameter pin or post insulators
- Special slits in the insulator covers help locate the conductor and hardware when installing the covers

P/N 9700-22454 C4060557 12" Tall 36 kV Phase-to-Phase
P/N 9700-40587 C4060557L 16.5" Tall 36 kV Phase-to-Phase

**RUBBER GOODS
& COVER-UPS**

**USA: 1-877-GO ALTEC
(1-877-462-5832)**

www.alteconnect.com

Please contact 1-877-GO ALTEC (1-877-462-5832) for additional information regarding Chance products.

Class 3 Conductor Covers



- 5' cover is ideal for covering long spans when weight is a consideration
- 26.4kV voltage rating
- 2" inside diameter
- May be connected with Salisbury 1.5" I.D. Class 3 or 4 flexible cover-up equipment
- Conductor covers connect easily with either plastic or rubber line hose

Part Number	Salisbury	Description
9000-21172	21172	5' Cover with Eye
9000-21315	21315	5' Cover with 4' Fiberglass Stick

Straight Line Hose



- Orange Type II SALCOR® line hose with RIB-GRIP® locking system
- Hoses remain flexible even in cold weather and are not damaged by ozone or ultraviolet rays
- Other sizes and classes are available

Part Number	Salisbury	Type	Class	Rating	I.D. x Length
9000-01253	OR125-3	II	2	17kV	1.25" x 3'
9000-12545	OR125-45	II	2	17kV	1.25" x 4.5'
9000-01256	OR125-6	II	2	17kV	1.25" x 6'
9701-06332	OR150-3	II	3	26.5kV	1.5" x 3'
9700-97409	OR150-6	II	3	26.5kV	1.5" x 6'

Line Hose Connectors



- Conventional line hose connector is made from Type II orange SALCOR®
- Can be used on 1", 1.25", or 1.5" I.D. conventional line hose

Part Number	Salisbury	Type	Class	I.D. x Length
9000-01250	ORC125	II	2	1.25" x 12"

Connector End Line Hose



- Type II orange SALCOR®
- Self-locking lip prevents line hose from coming off the conductor after installation is complete, yet still easy for linemen to assemble and disassemble
- RIB-GRIP® construction allows portions to easily slip together but resist coming apart
- Other sizes and classes are available

Part Number	Salisbury	Type	Class	Rating	I.D. x Length
9000-12530	OR125-3C	II	2	17kV	1.25" x 3'
9704-63953	OR125-45C	II	2	17kV	1.25" x 4.5'
9700-76912	OR125-6C	II	2	17kV	1.25" x 6'
9000-15060	OR150-6C	II	3	26.5kV	1.5" x 6'

Stinger Cover



- Protects against phase-to-phase and phase-to-ground wildlife contacts
- Track resistant
- May be installed without disconnecting the lead wire from the bushing
- Easy to cut to the necessary length
- Ozone and UV resistant SALCOR® elastomer

Part Number	Salisbury	Description	Rating
9700-81059	38-50SC	3/8" x 50' 1 coil	13kV
9700-81061	38-12SC	3/8" x 12' 4 pcs.	13kV
9700-81062	58-12SC	5/8" x 12' coil 4 pcs.	18kV
9700-81065	3412-SC	3/4" x 25' coil 4 pcs.	20.5kV

Silicone Bushing Cover

- Ozone and UV resistant silicone rubber
- Protect against wildlife contacts between energized equipment and ground by insulating exposed energized bushing parts
- Interlock with the top weathershed of the bushing and are securely fastened by inserting lock buttons
- Cover is 3.87" diameter x 3.37" tall



9700-81055 Left
9700-81056 Right

Part Number	Salisbury	Description
9700-81055	21116	Cover Only; 16kV
9700-81056	21116TC	Cover with Tube Closure; 16kV
9700-81058	21644	Tube Closure

Please contact your Altec Supply Account Manager for more information regarding quality Salisbury products.

SALISBURY

by Honeywell

HOT LINE TOOLS & ACCESSORIES

Rubber Insulating Blanket - Slotted



- Ozone-resistant Type II orange SALCOR[®] is manufactured from a blend of prime EPDM, offering supreme flexibility
- Use for covering ridge pins, cross arms with insulators or any place a wire, pin or projection interferes with proper placement of other cover-up devices

Part Number	Salisbury	Description
9000-01300	1300	Class 4, 28 Eyelets, 36" x 36"
9700-81049	1302	Class 4, 2" Hole, 36" x 36"
9700-81053	1304	Class 4, 4.5" Hole, 36" x 36"



Rubber Insulating Blanket - Solid

- Ozone-resistant Type II orange SALCOR[®] is manufactured from a blend of prime EPDM, offering supreme flexibility
- Will maintain color, flexibility, physical properties, and dielectric strength in the field longer than any other blanket on the market
- Reinforced, beaded edge

P/N 9000-09000 Salisbury 900E Class 4; 6 eyelets; 36" x 36"

Blanket Pins



- In addition to other uses, blanket clamp pins can be used to hold insulating blankets in place
- Springs are used for tension while extra holes in the body of the pin are used to grip conductors and prevent line hose from sliding
- Opens to a full 5.5", making these pins the most versatile on the market
- Tapered ends to accommodate any clampstick
- Fiberglass reinforced nylon with rubber tipped pin boots
- Use HS21 for applications and removal where a 90° angle is necessary

P/N 9000-02121 Salisbury 21

P/N 9700-81039 Salisbury HS21 For 90° Angle Applications

Blanket Buttons



- Designed to secure eyelet-style insulating blanket
- Made of yellow plastic, these buttons snap through the eyelet with thumb pressure on the large head

P/N 9000-45648 Salisbury B1

Voltage Detector



- Verifies presence of voltage with an extra-bright LED light and an audible signal
- Includes 3 "C" batteries, shotgun adapter, and case
- May be used with rubber insulating gloves or hot sticks using the splined universal end fitting

Part Number	Salisbury	Description
9000-99676	4356	240V to 230kV Detector
9007-04367	4367	240V to 500kV Detector
9007-04469	4469	240V to 69kV Detector

Blanket Canister



- 9" x 37"; holds up to six 36" blankets
- Molded in bright orange, high impact polyethylene with a tight fitting cap
- For easy retrieval, blankets can be rolled individually and stored in canister; a single blanket can then be removed without removing any others

P/N 9000-64551 P6 9" x 37"

*Other sizes available

RUBBER GOODS
& COVER-UPS

USA: 1-877-GO ALTEC
(1-877-462-5832)

www.alteconnect.com

Pole Guards

Features:

Class 5 rating

- Rated max use voltage of 48.3kV guarded phase to guarded phase or 27kV phase to ground.
- Allows use for applications up to 46kV system voltage

High Density Polyethylene:

- Completely recyclable HDPE material
- Excellent chemical resistance properties
- Superior electrical insulation properties
- Excellent cold and hot weather properties

Application:

- Highly visible orange pole guard covers are used to protect workers from accidental contact with a bare conductor when setting or removing poles in an energized work area. They can also be used to cover poles when performing energized maintenance in an insulated bucket, pole platform or hot sticking.
- Available in 4ft. or 6ft. lengths

P/N 9705-45598 Bierer PG48S (W/VELCRO STRAP)

P/N 9705-45599 Bierer PG72S (W/VELCRO STRAP)

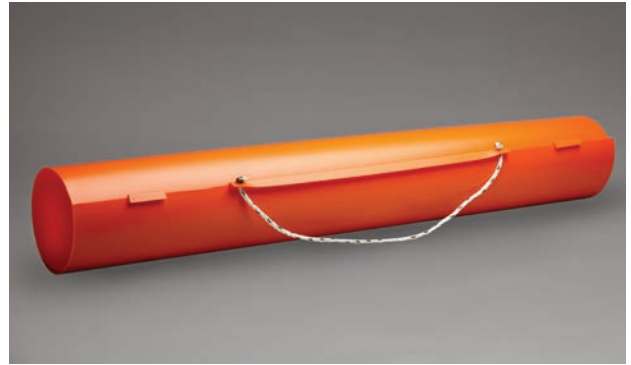

6 Foot Length



Profile of 6 Foot Pole Guard



4 Foot Length with Binding Strap



Profile of 4 Foot Pole Guard

NEW PRODUCTS

Highly Visible Protection!

Prevents accidental contact with a bare conductor when setting or removing poles in an energized work area



HASTINGS

A WORLDWIDE SUPPLIER OF
Hot Line Tools & Equipment

Rubber Goods & Cover-Ups

Rubber Blankets



- Designed, manufactured, and tested in strict compliance with ASTM D1048
- Class 2, Type I Blankets are produced from natural rubber (polyisoprene)
- Class 4, Type II Blankets are produced with ozone resistant EPDM synthetic rubber
- High visibility yellow allows the user to easily detect contamination, carbon tracking, and other damage that has occurred to the blanket

Part Number	Hastings	Description
9700-98618	6020	36" x 36" Solid Class 2 Type I
9700-98619	6020-1	36" x 36" Slotted Class 2 Type II
9700-98621	6040	36" x 36" Solid Class 4 Type I
9700-98622	6040-1	36" x 36" Slotted Class 4 Type II

Rubber Blanket Canisters

- For storage, quick access, and ease of use

Altec PN	Hastings	Description
9700-98528	6023	3 Blanket Cap.; 7" x 37"
9700-98529	6026	6 Blanket Cap.; ; 9" x 37"



Rubber Blanket Roll-Ups

- For storage, quick access, and ease of use
- For 36" x 36" blankets

P/N 9700-98530 01-071

Rubber Blanket Pins

Part Number	Hastings	Description
9700-98531	A30321	Blanket Pin; Plain Style
9700-98532	A30322	Blanket Pin; Hot Stick Style
9700-98533	01-604	Canvas Blanket Bag



15/25 kV Line Guard & Insulating Hood



- 15/25 KV
- Designed for easy installation and removal
- Line guards are 4'6" long
- Installation - Guards and hoods are equipped with eye and can be installed with all shotgun hot sticks
- Eyes are adjustable to allow guards to be installed at angles
- Interlocking male and female ends allow as many guards as needed to be installed on conductors
- 15/25 KV - Guards are designed for use on conductor sizes 6 solid through 666.6 26/7 ACSR
- Brush contact only

P/N 9700-16339 12936 4' 6"

25 kV Line Guard



- Lightweight polyethylene material (less than 1/2 the weight of rubber hoses)
- Rated at 26.4 kV phase to phase, 15.3 kV phase to ground
- Exceeds ASTM F712, F968, Class 3 electrical requirements

P/N 9701-38297 6055 5' x 1.77 I.D.
P/N 9700-94042 6065 6' x 1.77 I.D.

15 kV Polyethylene Line Guard



- Light weight (1/3 the weight of similar rubber hoses)
- Rated at 8.4 kV phase-to-ground and 15kV phase-to-phase (brush contact only)
- Features a larger I.D. than traditional rubber hoses (1.77" compared to 1.25"

- Snap together feature with male and female connecting ends
- Smooth polyethylene surface is easy to clean
- Meet both ASTM F712 and F968, Class 2 Electrical requirements
- Conductor clamp pin may be used to keep guards from sliding down the conductor

P/N 9000-06050 6050 5'
P/N 9700-18234 6060 6'



RUBBER GOODS
& COVER-UPS

USA: 1-877-GO ALTEC
(1-877-462-5832)

www.alteconnect.com





LINEMAN GRADE GLOVES

From the name you trust and the brand you depend on, Chance Tools are optimally designed.

Featuring the ultimate protection you expect from the Chance name, our Lineman Grade Gloves also offer a new level of comfort and flexibility. Incorporating high dielectric and physical strength, these gloves exceed ASTM D120.



Rubber Insulating Gloves and Sleeves

with the features and selections you need to get the job done:

- Ergonomic design for maximum dexterity and comfortable fit
- Manufactured in world-class ISO 9001 / ISO 14001 facility
- Earth-friendly processes limit CO2 and Volatile Organic Emissions

Gloves: Contour Cuff

- Colors: Contour Cuff: Yellow under Black and Red under Black
- Classes: 2, 3, 4.
- Sizes: 8 through 12 plus 8.5, 9.5 and 10.5
- Length: 18"

Straight or Bell Cuff

- Colors: Straight: Yellow, Black, Red, Black under Yellow
- Colors: Bell Cuff: Yellow under Black and Red under Black
- Classes: 00, 0, 1, 2, 3, 4.
- Sizes: 8 through 12 plus 8.5, 9.5 and 10.5
- Lengths of 11", 14", 16" and 18"



Chance Lineman Grade Gloves are manufactured using environmentally conscious processes that make the most efficient use of raw materials and natural resources. When you wear our gloves you are also helping limit VOC and CO2 emissions.

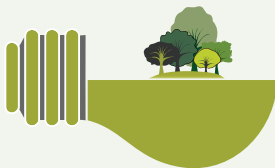

Class	Max. Use Voltage AC/DC	Proof Test Voltage AC/DC	Glove Label Color
00	500 / 750	2,500 / 10,000	
0	1,000 / 1,500	5,000 / 20,000	
1	7,500 / 11,250	10,000 / 40,000	
2	17,000 / 25,500	20,000 / 50,000	
3	26,500 / 39,750	30,000 / 60,000	
4	36,000 / 54,000	40,000 / 70,000	

Please contact 1-877-GO ALTEC (1-877-462-5832) for additional information regarding Chance products.

LINEMAN GRADE GLOVES

Leather Protector Gloves

Crafted to fit properly over all industry-standard rubber insulating gloves with full compliance with ASTM F496 Standard Specification for Leather Protectors for Rubber Insulating Gloves and Mittens.



Low Voltage Leather Protectors

- Goatskin-soft, flexible, strong
- Nylon strap with non-metallic buckle
- Note: 13" have polymeric/leather cuff

Low Voltage

Size	Catalog No.	
	10-inch Length	13-inch Length
7	PN 9705-67172 PSCGLP10GN7	PN 9705-67178 PSCGLP13GN7
8-8½	PN 9705-67173 PSCGLP10GN8	PN 9705-67179 PSCGLP13GN8
9-9½	PN 9705-67174 PSCGLP10GN9	PN 9705-67180 PSCGLP13GN9
10-10½	PN 9705-67175 PSCGLP10GN10	PN 9705-67181 PSCGLP13GN10
11	PN 9705-67176 PSCGLP10GN11	PN 9705-67182 PSCGLP13GN11
12	PN 9705-67177 PSCGLP10GN12	PN 9705-67183 PSCGLP13GN12



High Voltage Leather Protectors

- Cowhide - durable and flexible
- Hi-visibility polymeric/leather cuff
- Nylon Strap with non-metallic buckle
- Note: 16" fit straight and contour gloves

High Voltage

Size	Catalog No.	
	12-inch Length	14-inch Length
8-8½	PN 9705-67184 PSCGLP12CN8	PN 9705-67189 PSCGLP14CN8
9-9½	PN 9705-67185 PSCGLP12CN9	PN 9705-67190 PSCGLP14CN9
10-10½	PN 9705-67186 PSCGLP12CN10	PN 9705-67191 PSCGLP14CN10
11	PN 9705-67187 PSCGLP12CN11	PN 9705-67192 PSCGLP14CN11
12	PN 9705-67188 PSCGLP12CN12	PN 9705-67193 PSCGLP14CN12

High Voltage

Size	Catalog No.	
	15-inch Length	16-inch Length
8-8½	PN 9705-67194 PSCGLP15CN8	PN 9705-67199 PSCGLP16CN8
9-9½	PN 9705-67195 PSCGLP15CN9	PN 9705-67200 PSCGLP16CN9
10-10½	PN 9705-67196 PSCGLP15CN10	PN 9705-67201 PSCGLP16CN10
11	PN 9705-67197 PSCGLP15CN11	PN 9705-67202 PSCGLP16CN11
12	PN 9705-67198 PSCGLP15CN12	PN 9705-67203 PSCGLP16CN12



Glove Liners

- 100% Cotton for warmth and comfort under rubber insulating gloves
- One size to fit most
- Two weight/length choices
- Reversible to fit either hand

Glove Class	Minimum Distance between Protectors and Rubber Gloves	
	in.	mm
00.0	1/2	13
1	1	25
2	2	51
3	3	76
4	4	102

Clearance Table for Leather Protectors Per ASTM F496

Please contact 1-877-GO ALTEC (1-877-462-5832) for additional information regarding Chance products.

RUBBER GOODS & COVER-UPS

USA: 1-877-GO ALTEC
(1-877-462-5832)

www.alteconnect.com

LINEMAN GRADE GLOVES

Combination Glove and Sleeve Bag

- 18" L x 8" W
- Separate storage for rubber gloves and sleeves
- Single flap, double nylon stitching, velcro fasteners.
- (Gloves and Sleeves not included)

P/N 9704-54595 C4170150



P/N 9704-54595



P/N 9702-92526

Glove Bag

- 18" L x 8" W
- One piece front and back, bar-tacked at all corners
- Double nylon stitching, velcro flap fasteners
- Gusset has 4-inch top tapering to 2-inch bottom
- (Gloves not included)

P/N 9702-92526 C4170148



P/N 9704-54599

Sleeve Bag

- 27" L x 12" Top and 7" Bottom
- For flat storage of rubber sleeves
- Bar-tacked corners, velcro flap fasteners, double nylon stitching
- (Sleeves not included)

P/N 9704-54599 C4170149

Canvas Glove Bag

- 18" L x 8" Top
- For flat storage of rubber gloves

PN 9705-67204 PSCGLB18CCG



9705-67204



9705-67205

Canvas Sleeve Bag

- 30" L x 13" Top
- For flat storage of rubber sleeves
- Specially designed for extra-curved sleeves
- Velcro® strap inside at top to hang sleeves in place

PN 9705-67205 PSCGLB30CCS

Sleeve Straps and Buttons

- Two straps and four buttons are required to properly wear each pair of sleeves
- Straps are 15" in length
- Buttons are two-piece, screw-type



P/N 9704-57839 PSCS1 Strap Set
(includes 2 Straps & 4 Buttons)



P/N 9704-57842 PSC4060600
Sleeve Buttons (includes 4 pair)



Snaphook on each bag

For suspending from belt or in storage
Leather reinforced tab is stitched to the
back of each bag



P/N 9704-57843 PSC4060610 Straps Only

Please contact 1-877-GO ALTEC (1-877-462-5832)
for additional information regarding Chance products.



Novax[®] Rubber Insulating Gloves

BELL CUFF STYLES

Item #	Class	Length	Size	Color
154-2-16*	2	16"	8-12	Black/Yellow
159-2-16	2	16"	9-12	Black/Orange
161-2-16*	2	16"	8-12	Black/Red
154-2-18	2	18"	8-12	Black/Yellow
159-2-18	2	18"	9-12	Black/Orange
161-2-18	2	18"	8-12	Black/Red
159-3-16	3	16"	9-12	Black/Orange
159-3-18	3	18"	9-12	Black/Orange
159-4-16	4	16"	9-12	Black/Orange
159-4-18	4	18"	9-12	Black/Orange

*Half sizes are available for this style (8.5, 9.5, 10.5, 11.5)

The contoured shape and softness reduces hand fatigue

Individually numbered for traceability and stamped with factory manufacturing date

Bell cuff increases comfort on the job

Inspected and packed according to the requirement in ASTM D120 and EN 60903



Novax[®] Contour Cuff Styles



Designed for increased mobility and comfort on the job
18" long glove, unlined with a smooth finish
Class 1 & 2 available in sizes 8-12
Class 3 & 4 available in sizes 9-12

Item #	Class	Length	Size	Color
158-1-18	1	18"	8-12	Black/Orange
151-2-18*	2	18"	8-12	Black/Yellow
158-2-18	2	18"	8-12	Black/Orange
162-2-18	2	18"	8-12	Black/Red
151-3-18	3	18"	9-12	Black/Yellow
158-3-18	3	18"	9-12	Black/Orange
158-4-18	4	18"	9-12	Black/Orange

*Half sizes are available for this style (8.5, 9.5, 10.5, 11.5)



Leather Protector Glove Covers

Item #	Class	Length	Size	Description
148-1000	00-0	10"	7-12	Goatskin Driver Cuff
148-2000	00-0	13"	7-12	Goatskin Gauntlet Cuff
148-4000	1-2	12"	7-12	Cowskin Gauntlet Cuff
148-5000	1-2	12"	7-12	Goatskin Gauntlet Cuff
148-6000	1-4	14"	8-12	Goatskin Gauntlet Cuff
148-7000	3-4	14"	9-12	Goatskin Gauntlet Cuff

Leather Protectors are to be used only for mechanical protection for rubber gloves and mittens and shall not be used for electrical protection per ASTM F696-02. The correct length of leather protectors is found in ASTM F496-06.



Storage Bags

Altec P/N	Item #	Description	Length	Color
9704-92564	148-2136	Nylon Glove Bag	11"	Black
9704-92662	148-2142	Nylon Glove Bag	14"	Black
9704-92566	148-6011	Canvas Glove Bag	11"	Natural
9704-70269	148-6014	Canvas Glove Bag	14"	Natural
9704-92567	148-6016	Canvas Glove Bag	16"	Natural
9704-92678	148-6018	Canvas Glove Bag	18"	Natural



NOVAX[®]

ELECTRICAL SAFETY

The Natural Rubber Construction offers excellent dielectric properties combined with flexibility, strength, & durability

RUBBER GOODS
& COVER-UPS



**PIP's Novax
Gloves are
almost always
available for
immediate
shipment**

Novax[®] products exceed all requirements of ASTM D120, insuring compliance with OSHA regulations and satisfying NFPA 70E requirements for protection against electrical shock hazards. The natural rubber construction offers excellent dielectric properties combined with flexibility, strength and durability. other features include a contoured shape which reduces hand fatigue and a rolled cuff for increased durability during donning and doffing.

USA: 1-877-GO ALTEC
(1-877-462-5832)

www.alteconnect.com



NOVAX[®] RUBBER INSULATING GLOVES

STRAIGHT CUFF STYLES

CLASS	LENGTH	COLOR	ALTEC #	STYLE #
00	11"	Black	9704-92683 SZ 7 9704-92684 SZ 8 9704-92685 SZ 9 9704-92686 SZ 10 9704-92687 SZ 11 9704-92688 SZ 12	150-00-11
00	11"	Orange	9704-92629 SZ 7 9704-92630 SZ 8 9704-92631 SZ 9 9704-92632 SZ 10 9704-92633 SZ 11 9704-92634 SZ 12	147-00-11
00	11"	Yellow		170-00-11
00	14"	Black	9704-92689 SZ 7 9704-92690 SZ 8 9704-92691 SZ 9 9704-70254 SZ 10 9704-70262 SZ 11 9704-92692 SZ 12	150-00-14
00	14"	Yellow		170-00-14
0	11"	Black	9704-92693 SZ 7 9704-92694 SZ 8 9704-92695 SZ 9 9704-92696 SZ 10 9704-92697 SZ 11 9704-92698 SZ 12	150-0-11
0	11"	Orange	9704-92635 SZ 7 9704-92636 SZ 8 9704-92637 SZ 9 9704-92638 SZ 10 9704-92639 SZ 11 9704-92640 SZ 12	147-0-11
0	11"	Black/Orange	9704-92738 SZ 7 9704-92739 SZ 8 9704-92740 SZ 9 9704-92741 SZ 10 9704-92742 SZ 11 9704-92743 SZ 12	155-0-11
0	11"	Yellow		170-0-11
0	14"	Black	9704-92699 SZ 7 9704-92700 SZ 8 9704-92701 SZ 9 9704-92702 SZ 10 9704-92703 SZ 11 9704-92704 SZ 12	150-0-14
0	14"	Yellow		170-0-14
1	14"	Black	9704-92705 SZ 7 9704-92706 SZ 8 9704-92707 SZ 9 9704-92708 SZ 10 9704-92709 SZ 11 9704-92710 SZ 12	150-1-14
1	14"	Orange	9704-92641 SZ 7 9704-92642 SZ 8 9704-92643 SZ 9 9704-92644 SZ 10 9704-92645 SZ 11 9704-92646 SZ 12	147-1-14
1	14"	Black/Orange	9704-92744 SZ 7 9704-92745 SZ 8 9704-92746 SZ 9 9704-92747 SZ 10 9704-92748 SZ 11 9704-92749 SZ 12	155-1-14

SIZES: Class 3-4 sizes available 9-12, class 00-2 sizes available 7-12.

* Black class 3 and 4 gloves are special order items.



NOVAX® RUBBER INSULATING GLOVES
STRAIGHT CUFF STYLES

CLASS	LENGTH	COLOR	ALTEC #	STYLE #
1	14"	Yellow		170-1-14
1	16"	Black/Orange	9704-92750 SZ 9 9704-92751 SZ 10 9704-92752 SZ 11 9704-92753 SZ 12	155-1-16
2	14"	Black	9704-92711 SZ 7 9704-92712 SZ 8 9704-92713 SZ 9 9704-92714 SZ 10 9704-92715 SZ 11 9704-92716 SZ 12	150-2-14
2	14"	Orange	9704-92647 SZ 7 9704-92648 SZ 8 9704-92649 SZ 9 9704-92650 SZ 10 9704-92651 SZ 11 9704-92539 SZ 12	147-2-14
2	14"	Black/Orange	9704-92754 SZ 7 9704-92755 SZ 8 9704-92756 SZ 9 9704-92757 SZ 10 9704-92758 SZ 11 9704-92759 SZ 12	155-2-14
2	14"	Yellow		170-2-14
2	16"	Black/Orange	9704-92760 SZ 9 9704-92761 SZ 10 9704-92762 SZ 11 9704-92763 SZ 12	155-2-16
3	16"	Black	9704-92717 SZ 8 9704-92718 SZ 9 9704-92719 SZ 10 9704-92720 SZ 11 9704-92721 SZ 12	150-3-16*
3	16"	Black/Orange	9704-90372 SZ 9 9704-90373 SZ 10 9704-92768 SZ 11 9704-92769 SZ 12	155-3-16
3	18"	Black	9704-92722 SZ 8 9704-92723 SZ 9 9704-92724 SZ 10 9704-92725 SZ 11 9704-92726 SZ 12	150-3-18*
3	18"	Black/Orange	9704-92770 SZ 9 9704-92771 SZ 10 9704-92772 SZ 11 9704-92773 SZ 12	155-3-18
4	16"	Black	9704-92727 SZ 9 9704-92728 SZ 10 9704-92729 SZ 11 9704-92730 SZ 12	150-4-16*
4	16"	Black/Orange	9704-90374 SZ 9 9704-90375 SZ 10 9704-92774 SZ 11 9704-92775 SZ 12	155-4-16
4	18"	Black	9704-92731 SZ 8 9704-92732 SZ 9 9704-92733 SZ 10 9704-92734 SZ 11 9704-92568 SZ 12	150-4-18*
4	18"	Black/Orange	9704-92776 SZ 9 9704-92777 SZ 10 9704-92778 SZ 11 9704-92779 SZ 12	155-4-18

SIZES: Class 3-4 sizes available 9-12, class 00-2 sizes available 7-12.
* Black class 3 and 4 gloves are special order items.

Most sizes are Altec numbers are included in this chart; however, if a color or size is not shown that you are needing, please contact your Altec Supply Account Manager or call 1-877-GO ALTEC (1-877-462-5832) for more information on ordering that item.



**RUBBER GOODS
& COVER-UPS**

USA: 1-877-GO ALTEC
(1-877-462-5832)

www.alteconnect.com

SALISBURY

by Honeywell LINEMAN'S GLOVES

RUBBER GOODS
& COVER-UPS

USA: 1-877-GO ALTEC
(1-877-462-5832)

www.alteconnect.com



Please use the Glove Configurator on www.whsalisbury.com for assistance in ordering the correct gloves

SALISBURY LINEMAN'S GLOVES - LOW VOLTAGE ASTM Class 00 Gloves

Class	Length	Color	Size
E 00	11	R, B, BL, or BLO	7, 8, 8H, 9, 9H, 10
E 00	14	R, B, BL, or BLO	10H, 11, 11-1/2, 12

R=Red B=Black: Type I Natural Rubber
BL=Blue BLO=Blue in, orange out: Type II SALCOR®
Example: E0011BL/8

SALISBURY LINEMAN'S GLOVES - LOW VOLTAGE ASTM Class 0 Gloves

Class	Length	Color	Size
E 0	11	Y, B, R, BL, BLO or BY	7, 8, 8H, 9, 9H, 10,
E 0	14	Y, B, R, BL, BLO or BY	10H, 11, 11-1/2, 12

R=Red B=Black Y=Yellow: Type I Natural Rubber
BY=Black in, yellow out: Type I Natural Rubber
BL=Blue BLO=Blue in, orange out: Type II SALCOR®
Example: E014R/9

* The contrast between the outer orange color and the inner blue color makes inspecting for cuts and tears easier when the glove is inflated or stretched.

DETERMINE YOUR GLOVE SIZE

Measure the circumference of your palm (hand laying flat), following a line across your knuckles.



Add 1" to this measurement, and this is your glove size.

For example, if you measure 9", add 1", and your glove size is size 10.

SALISBURY LINEMAN'S GLOVES - HIGH VOLTAGE

ASTM Class 1, 2, 3, 4 Gloves

Class	Length	Cuff Style***	Color	Size
E 1	14,16, or 18	BC***, C	B, YB, or RB	7, 8, 8H, 9, 9H, 10,
E 2	14,16, or 18	BC***, C	B, YB, or RB	10H, 11, 11H, 12
E 3*	14,16, or 18	BC***, C	B, YB, or RB	
E 4**	14,16, or 18	BC***, C	B, YB, or RB	

FC=Flare cuff BC=Bell cuff C=Contour cuff (Straight cuff is the default style)

* available in sizes 8-12 including half sizes only

**available in sizes 9-12 including half sizes only

B=Black YB=Yellow inside, black out RB=Red inside, black out: Type I Natural Rubber

Example: E116BCB/10

Example if ordering straight cuff: E116YB/10

***bell cuff gloves available in sizes 9 through 12 including half sizes only

FOR ADDITIONAL
GLOVE OPTIONS, CALL
1-877-GO ALTEC
(1-877-462-5832)



SAMPLING OF RUBBER GLOVES

P/N 9000-21615 E216YB/10H Class 2; 16" Length; Standard Cuff; Yellow Inside, Black Out; Size 10.5
P/N 9000-21690 E216YB/9 Class 2; 16" Length; Standard Cuff; Yellow Inside, Black Out; Size 9
P/N 9000-21601 E216YB/10 Class 2; 16" Length; Standard Cuff; Yellow Inside, Black Out; Size 10
P/N 9000-21695 E216YB/9H Class 2; 16" Length; Standard Cuff; Yellow Inside, Black Out; Size 9.5



Please contact your Altec Supply Account Manager for more information regarding quality Salisbury products.

SALISBURY

by Honeywell

LEATHER PROTECTORS



PREMIUM SERIES



ILPG10



ILPG10A



ILP7C



LPG3S



LP7C



LPG5S

Salisbury Advantage Premium Series

- Made from specially tanned Grade A Red Boulevard buffed leather and an orange colored SALCOR® "Super Cuff"
- Super cuff does not absorb water and has greater track resistance and creepage than leather or vinyl cuffs
- Available in 4" straight cuff (12" overall) or 6" straight cuff (14" overall)
- SALCOR® cuff provides maximum protection
- Dual sizes: 8/8.5, 9/9.5, 10/10.5, 11/11.5, 12

Minimum Distance from Protector and Rubber Glove	Glove Class	Leather Protector Cuff Cuff Line
	00, 0	1/2"
1	1/2"	1" from cuff
2	1"	2" from cuff
3	2"	3" from cuff
4	3"	4" from cuff
	4"	

To Place an LP Series Order:

Specify LP for Cowhide or LPG for Goatskin
Specify Code for Overall Length
Specify Cuff Style - (S) Straight, (C) Contour
Specify Size*

* Available in single sizes: 8, 8.5, 9, 9.5, 10, 10.5, 11, 11.5, 12

To Place an ILP Series Order:

Specify ILP for Cowhide or ILPG for Goatskin
Specify Code for Overall Length
Specify Cuff Style - (S) Straight, (C) Contour
Specify Size*

* Available in dual sizes: 7, 8/8.5, 9/9.5, 10/10.5, 11/11.5, 12
Goatskin is not available in size 7

Please use the Glove Configurator on www.whsalisbury.com for assistance in ordering the correct gloves

SALISBURY SLEEVES

To Place a Molded Type II Sleeves Order

VOLTAGE CLASS	SIZE	COLOR
1	R or L	BS or OS
2	R, L, XL	BS or OS

R=regular L=large XL=extra large
BS = black SALC
Example: 2LOS

To Place a Molded Type I Sleeves Order

VOLTAGE CLASS	SIZE	COLOR
1	R or L	Y
2	R, L, XL	B, Y, or M
3	R or L	Y, M
4	R or L	M

R=regular L=large XL=extra large
B=black Y=yellow M=maroon
Example: 2LB

To Place a Dipped Type I Sleeves Order

VOLTAGE CLASS	SIZE	COLOR
D0	S,R, L, XL	Y=yellow R=red
D1	S,R, L, XL	B=black
D2	S,R, L, XL	YB=Y inside, B out
D3	S,R, L, XL	RB=R inside, B out
D4	S,R, L, XL	YR=Y inside, R out
Example: 2LOS		RY=R inside, Y out
R = regular L = large XL = extra large		ST = straight cuff EC = extra curved cuff Ex: D2LYB

Extra-Curved Arm
D2IYR-EC

Straight Arm
D2RYB-ST

479

Altec Supply

RUBBER GOODS & COVER-UPS

USA: 1-877-GO ALTEC
(1-877-462-5832)

www.alteccconnect.com

Sleeve Bags



- Constructed of heavy duty canvas and double stitched and riveted at stress points, Salisbury bags are extra durable
- Canvas bags feature a D ring for hanging in trucks or on work belts and tapered gussets
- Feature wide opening tops for easy insertion

P/N 9000-31000 30" x 9.5"

P/N 9700-80097 30" x 13"

Folds and creases strain rubber and cause it to crack from ozone prematurely. By storing rubber sleeves in the right size bag, and never forcing more than one pair into each bag, equipment will lie flat and extend the life of the product.

Canvas Double Glove Bags



- Made of heavy duty canvas fabric
- All bags have nickel plated industrial type snaps and two ventilation eyelets in the bottom of the bag
- Stores sets of high and low voltage gloves, rubber gloves, and leather protectors
- 19" x 8" x 6"

P/N 9700-71579

Salisbury Glove Kits



For every electrical worker's complete safety, Salisbury glove kits keep insulating rubber gloves in top condition, providing proper storage to ensure protection against cuts, abrasions, and punctures. Call for availability.

Product Numbering Chart for Glove Kits

Class	Length	Color	Size of Gloves
GK 00	11 or 14	B, R, B, BL	7, 8, 9, 10, 11, 12
GK 0	11 or 14	R, BL, B, Y	7, 8, 9, 10, 11, 12
GK 2	14, 16, or 18	B, RB	7, 8, 9, 10, 11, 12

Example: GK011BL/9
Type I Natural Rubber available in: R=Red, Y= Yellow, B=Black
RB=Red in, Black out
Type II SALCOR® Rubber available in: BL=Blue

IF YOU REQUIRE TEST DATE STAMPING, PLEASE SPECIFY WHEN ORDERING

Sleeve Buttons & Straps



- Sleeve buttons, straps, and harnesses are required to wear rubber insulating sleeves properly

P/N 9000-20521

P/N 9000-20521 B2 1-Piece Sleeve Button
P/N 9700-80101 B22 4 Screw Type Button

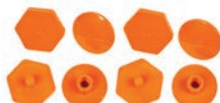

P/N 9700-80101

Glove & Protector Bags



Single Pocket Bag:

P/N 9700-80008 For 14" Gloves; 9" x 16"

P/N 9700-80092 For 16" Gloves; 9" x 18"

P/N 9700-80094 For 18" Gloves; 9" x 20"

Double Pocket Bag:

(Holds pair of gloves and pair of protectors)

P/N 9702-54647 For 14" Gloves; 9" x 16"

P/N 9702-54648 For 16" Gloves; 9" x 18"

P/N 9702-47387 For 18" Gloves; 9" x 20"

Combination Sleeve & Glove Bags



- Made of heavy duty canvas fabric
- All bags have nickel plated industrial type snaps and two ventilation eyelets in the bottom of the bag
- Snap closure

P/N 9000-40034 For 14" gloves; 15" x 8" x 6"

P/N 9000-40038 For 16" gloves; 17" x 8" x 6"

P/N 9000-40042 For 18" gloves; 19" x 8" x 6"

Harness and Straps



- Four buttons, two straps, and one harness are required per pair of sleeves

P/N 9000-11168 Harness with 4 B2 buttons (shown left)

P/N 9000-11542 15" Strap with 4 B2 buttons (shown right)

Lineman's Rubber Overshoes



DIELECTRIC



SUPER DIELECTRIC

- Storm rubber overshoe; two buckles
- Ozone-resistant rubber is 100% waterproof
- Anti-skid bar



tread outsole

- Shoe construction is hand layered in full-cut patterns to fit over work boots
- Fabric lining provides ease of putting on and taking off
- Provide extra safety when climbing ladders

and poles where the deep heel cavity can lock onto the rungs

DIELECTRIC STORM RUBBER OVERSHOE

- 100% tested to 20 kV per ASTM F1116
- ASTM F1117 compliant

P/N 9700-80831 Size 9
P/N 9700-80835 Size 10
P/N 9700-80836 Size 11
P/N 9700-80837 Size 12

**For Additional
Boot Styles and Options
Call 1-877-GO ALTEC**

SUPER DIELECTRIC STORM RUBBER OVERSHOE

- 100% tested to 20 kV per ASTM F2413-05 - revised standards

P/N 9700-80840 Size 9
P/N 9700-80841 Size 10
P/N 9700-80842 Size 11
P/N 9700-80843 Size 12

SALISBURY

by Honeywell

RUBBER GOODS

Ten-Four Glove Dust



- A cooling, frictionless powder that absorbs moisture and perspiration when wearing rubber gloves
- Provides extra comfort while preventing gloves from getting sticky
- 5 oz. bottle easily fits into a pocket or glove bag
- Sold by the case

P/N 9000-10461 10-4 (12) 5 oz. bottles/case

Rub-Out Hand Cleaner



- A non-petroleum based hand cleaner for workers who wear rubber gloves and sleeves
- Dissolves and removes grease, oil, ink, tar, pipe dope, creosote, paint, and more without harming natural rubber or SALCOR® rubber
- Cleans with or without water
- Contains natural skin conditioners and leaves a fresh citrus scent
- Sold by the case

P/N 9000-00418 1451 (12) 16 oz. cans per case

Rub-Out Towelettes



- 10.5" x 12.25" pre-moistened heavy duty towelettes
- Loosens, dissolves, and absorbs dirt and grease
- Will not harm rubber gloves
- Remove tough to clean substances including lubricants, tar, oils, wax, and caulk

P/N 9000-00419 1460 Case of 6 Tubs; 60 Towelettes each
P/N 9000-00420 1461 100 Single Pack Towelettes

Super Salco Detergent



- Concentrated detergent with a special grease release formula that removes oils, grease, and dirt from natural rubber and SALCOR® rubber equipment
- Suitable for use in commercial washing machines or by hand
- Works well on fiberglass and other materials

P/N 9000-00421 S4 (4) 1 Gallon Jugs
P/N 9000-00422 S5 (1) 5 Gallon Drum

RUBBER GOODS

Portable Glove Inflator



- Lightweight and easy to use
- Provides a quality means of inspecting gloves in the field
- Glove is secured to the inflator by securing glove over the soft outer TPR material shell

- Includes the base unit, detachable hose and spigmo (black ball) that can be stored inside the unit with a carrying bag

P/N 9701-61729

RUBBER GOODS
& COVER-UPS

USA: 1-877-GO ALTEC
(1-877-462-5832)

www.alteccconnect.com



GREENLEE®

UTILITY
A Textron Company

ULTRA TUGGER

UT10-2S CABLE PULLER 10,000 LB. RATED

Speed

- 2-Speed gear motor enable 20% faster pulling time
- Shift from high-speed/low-load pulling to low-speed/high-load pulling with a simple double-tap motion on the foot pedal

Versatile

- Available with Mobile VersiBoom for less than 2 minute, 1 person set-up, and 20 feet tall
- Available with floor mount and chain mount for tighter spaces

Heavy Duty

- Customized gear motor
- specifically for heavy-duty cable pulling application and meet UL & cUL safety requirements

UNDERGROUND TOOLS
& EQUIPMENT

USA: 1-877-GO ALTEC
(1-877-462-5832)

www.alteconnect.com



HEAVY DUTY

VERSATILE



UT10-2S & MOBILE VersiBOOM™ II (SHOWN WITH BOOM EXTENSION)

Quick Set-Up

- One person set-up in less than 2 minutes

Versatile

- Can be extended up to 20'
- Use with one 3' boom for tighter spaces

Easy to store and transport

- Can be folded up in less than 2 minutes and can be stored on the back of a pick-up truck
- Fully contained unit



ALTEC P/N	CAT. NO.	DESCRIPTION
9704-44479	6906	UT10-2S Package with Mobile Versi-Boom II
9704-44491	MVB	Mobile Versi-Boom II
9704-44494	6900	UT10-2S Package with Floor Mount
9704-44496	6901	UT10-2S Package with Chain Mount

Rope: A Critical Link In The Cable Pulling System

Required Rope is 7/8" Diameter
Double-Braided Polyester Composite
Rated at 32,000 lbs. Minimum Breaking Strength

- Double-braided inner core with an extra double-braided outer jacket for added strength and less stretch; white with green tracer
- Rot and mildew resistant
- Factory spliced eyes at both ends



ALTEC P/N	CAT. NO.	DESCRIPTION
9000-00082	34136	7/8" Double-Braided Composite Rope, 300'
9000-00083	34137	7/8" Double-Braided Composite Rope, 600'
9000-00084	34138	7/8" Double-Braided Composite Rope, 1,200'

Fiberglass Fish Tape in Reel Stand



- High-impact nylon, one-piece handle for maximum durability and comfortable use
- Non-conductive fiberglass tape with low friction coating
- Unique non-coiling properties enable it to fish in large and small conduit equally well, even with wire or cable in place
- Fiberglass fish tape is the

fastest manual fish tape available
 • 3/16" diameter and 300 lbs. maximum design strength
P/N 9000-00045 Greenlee 542-250 250 Ft Fish Tape

Greenlee Poly Line - 6500 Ft



- Use with power fishing systems directly from the container
- Resists tangling when dispensing
- Rot and mildew resistant
- Handy reusable plastic dispenser pail with handle keeps the line dry
- Use to pull rope through conduit
- 210 lbs. average breaking strength
P/N 9000-00064 21481

Manhole Sheave

- High strength aluminum alloy frame for easy setup
- Adjustable, a full range of sheave pin positions to accommodate most manhole setups
- 18" diameter aluminum alloy sheaves with 7" minimum radius and 5" width
- Self-lubricating bearings for easier cable pulling
- Select a sheave with maximum rated capacity that meets or exceeds the cable puller's maximum pulling force

P/N 9000-00141 15345 10' (158 lbs.) Capacity 4,000 lbs.
P/N 9000-00143 31395 12' (190 lbs.) Capacity 6,500 lbs.

Hydraulic Cable Bender



- 600 volt
- 350 - 1000 kcmil capacity
- 350 - 750 kcmil compact cable
- One-shot bends up to 90° and automatically unloads cable
- Compact design bends in tight places
- Unit with foot pump keeps both hands free to hold cable
- Includes hydraulic cable bender with 1725a foot pump, high pressure hose unit and storage box

P/N 9700-71893 23893

Ratchet Cable Bender

- Capacity: through 500 kcmil (MCM), 600 volt, copper or aluminum cable
- Simplifies and speeds cable installation
- 10" ratchet extension is furnished to simplify bending in deep enclosures
- Includes ratchet wrench, L-wrench, ratchet extension, bending shoe assembly and storage box

P/N 9000-00426 796

Cable-Gel™ Cable Pulling Lubricant



- Polymer-based lubricant offers lower friction and easier pulling
- Environmentally safe and non-hazardous
- Compatible with all cable insulation types
- Higher lubricity than competitive products; will not cement itself to the pipe
- Dries slowly; apply by hand

or pump
 • Will not break down or separate after exposure to heat or cold
 • Viscosity 8,000 - 12,000 CPS PH Range 7.0 - 8.0
P/N 9000-00154 Greenlee 35213

Cable Guide



- Helps protect cable from being damaged on sharp edges

P/N 9000-99583 489



G3 TUGGER™ CABLE PULLER

SAVE TIME & MONEY WITH EVERY PULL

ADJUSTABLE

Clamp easily adjusts for different sizes of conduit

PORTABLE

Handle and wheels for increased mobility around jobsites

SAFER

Right angle sheave safely keeps operators out of direct line of pulls

EASIER

Change tail length, pull direction, and angle of pull with ease

FASTER

Dual capstan pulls:
High Speed: 97 ft/min
Low Speed: 41 ft/min

VERSATILE

Can hook on the back of a truck hitch

PULLING FORCE

Continuous Rating: 1200 lbs.
Intermittent Rating: 2000 lbs.

DEPENDABLE

Customized motor with circuit breaker specifically designed for cable pulling

P/N 9706-40813 G3



FASTER

- 20% faster cable pulls*
- High-speed pulls up to 1,000 lbs.

STRONGER

- 25% stronger continuous pulling load*
- Durable motor designed for pulling efficiency

EASIER

- 3x faster setup*
- No loose pieces

*When compared to competitive models





Power Vac 690-15

UNDERGROUND TOOLS
& EQUIPMENT

USA: 1-877-GO ALTEC
(1-877-462-5832)

www.alteconnect.com



PERFORMANCE

- Industrial strength two-stage motor for long runs and extended life.

DURABILITY

- Toughened 1/4" thick walls
- Washable stainless steel filter

MOBILITY

- Rugged 8" wheels with dual front casters
- 15' hose for maximum versatility on the jobsite

SPECIFICATIONS

- Voltage 120VAC
- Peak Amperage 11.8A
- Motor Type Two-Stage Bypass
- Impellor Size (In.) 7.2
- Max Vacuum (In. of Water) 112.8
- Max Blower (PSI) 4.0
- Max Airflow (CFM) 107.0
- Tank Capacity (US Gallons) 12
- Shipping Weight (lbs.) 58.6

**Designed & Assembled
in the USA**



Long 15' hose
for higher and harder
to reach locations.

**Steel transport
handle and rugged
8" wheels**
for easy
movement
around the
jobsite.

**Large, durable
outer tank.**
Impact resistant
for long life.



Industrial two-stage motor
for consistent pressure over long runs.

Washable, stainless steel filter
for easy cleaning – no need to replace filter.

P/N 9706-37189	690-15	690 Power Fishing System - 15' Hose
P/N 9706-37190	690-RM	Replacement Motor Kit for 690
P/N 9706-37191	690-RT	Replacement Tank Kit for 690
P/N 9706-37192	RH10	10' x 1½" Vacuum/blower Hose
P/N 9706-37193	RH15	15' x 1½" Vacuum/blower Hose
P/N 9706-37194	RH25	25' x 1½" Vacuum/blower Hose
P/N 9706-37195	390	390 Li'l Fisher™ Power Fishing Unit
P/N 9000-99509	591	591 Mighty Mouser™ Portable Blower Fishing System
P/N 9706-37196	00592	Mighty Mouser™ Blow Gun Kit
P/N 9703-29294	392	Power Fishing Accessory Kit
P/N 9000-00064	430	Poly Line Bucket – 6,500 ft, 210 lb. (Green Tracer)
P/N 9706-37197	430-500	Poly Line Dispenser – 500 ft, 210 lb. (Green Tracer)
P/N 9000-00065	431	Poly Line Bucket – 5,200 ft, 240 lb. (Yellow Tracer)
P/N 9000-00066	37959	Poly Line Bucket – 2,200 ft, 500 lb. (Red Tracer)
P/N 9000-00071	435	Conduit Measuring Tape – 3/16" x 3,000 ft. 170lb.
P/N 9706-37198	4435	Polyester Pull/Measure Tape – ½" x 3,000 ft. 1,250 lb.
P/N 9706-37199	4436	Polyester Pull/Measure Tape – 5/8" x 3,000 ft. 1,800 lb.
P/N 9706-37200	4437	Polyester Pull/Measure Tape – ¾" x 3,000 ft. 2,500 lb.
P/N 9706-40812	24779	½" – 4" Piston Set for All Conduit
P/N 9000-99526	S2613	½" – 2" Piston Set for All Conduit
P/N 9000-99527	34317	2½" – 4" Piston Set for EMT Conduit



UNDERGROUND TOOLS & ACCESSORIES

Lube Spreader Swab



- Spreads a coat of wire lubricant in duct before installation of cable
- Cleans mud, dirt, and light debris from duct before pulling
- Will not damage inner walls of duct
- Maximum rated capacity 4,800 lbs.
- Tapered shape permits bi-directional use

Swab	Greenlee	Duct Size	Max. Disk Size
P/N 9000-00162	16854	2"	1 3/4"
P/N 9000-00163	16856	2 1/2"	2 1/4"
P/N 9000-00164	16857	3"	2 3/4"

Woven Aramid* High Strength Conduit Measuring Tape

- Pull small cables or install pull rope for large cable pulling jobs
- Will not rot or deteriorate; can be left in ducts indefinitely for future use
- Low stretch properties make measurements accurate
- Printed measurements every foot from zero to 3000'

P/N 9000-00073	39143	1/4" x 3,000'	1,250 lb. capacity
P/N 9000-00074	39144	3/8" x 3,000'	1,800 lb. capacity
P/N 9000-00075	39245	1/2" x 3,000'	2,500 lb. capacity

* Woven Aramid material equivalent to Kevlar®



Conduit Pistons



- Use with blower or vacuum power fishing system to pioneer the line through the conduit run
- Color coded end disk with embossed size markings for fast, easy selection
- Strong steel center rod with loops on both ends
- Pistons available for all types, sizes of conduit 1/2" to 6"
- Flexible foam body for an airtight seal

Part Number	Greenlee	Conduit Size	Conduit Type
9000-99510*	608-5	1/2"	All
9000-99511*	609-5	3/4"	All
9000-99512*	610-5	1"	All
9000-99513*	611-3	1 1/4"	All
9000-99514*	612-2	1 1/2"	All
9000-99515	613	2"	All
9000-99516	614	2 1/2"	IMC, Rigid
9000-99517	621	2 1/2"	EMT
9000-99518	615	3"	IMC, Rigid
9000-99519	622	3"	EMT
9000-99520	616	3 1/2"	IMC, Rigid
9000-99521	646	3 1/2"	EMT
9000-99522	617	4"	IMC, Rigid
9000-99523	623	4"	EMT
9000-99524	618	5"	All
9000-99525	619	6"	All
9000-99526*	S2613	1/2"- 2"	All
9000-99527*	34317	2 1/2"- 4"	EMT

* Multi-packages

Portable Power Blower Fishing System

- Powerful, will blow line or measuring tape in up to 4" conduit
- Portable, lightweight blower has a shoulder strap to make it easy to carry and allow the operator to have both hands free
- Efficient, includes the Mighty Mouser[®] blow gun for fast, easy line blowing

System Includes:

- Mighty Mouser Blow Gun
- 2,150' of 85 lbs. strength Fish line
- Adapter Cone 1/2" - 1" conduit
- Adapter Cone 1 1/4" - 2 1/2" conduit
- Adapter Cone 3" - 4" conduit
- Flexible hose 1 1/2" dia. x 1'
- Hose Clamp
- Storage Box
- Pistons 9000-99510 through 9000-99523
- Adapter Nozzle for Tape and Line
- Portable Blower
- Flexible Hose 1 1/2" dia. x 4'
- 1/2" Conduit x 150' Line pkg. 10 qty.
- 3/4" Conduit x 200' Line pkg. 5 qty.
- 3/4" Conduit x 450' Line pkg. 5 qty.
- 1" Conduit x 200' Line pkg. 5 qty.
- 1" Conduit x 450' Line pkg. 5 qty.



P/N 9000-99509 Greenlee 591

UNDERGROUND TOOLS & EQUIPMENT

GATOR Grips™ Crimp-On Cable Pulling Grips

ALTEC P/N	GREENLEE	DESCRIPTION	OVERALL LENGTH
9703-66405	GG1-1/0S	SHORT	20-1/2"
9703-66406	GG1-1/0M	MEDIUM	27-1/2"
9703-66407	GG1-1/0L	LONG	34-1/2"
9703-66410	GG2/0-4/0S	SHORT	20-1/2"
9703-66411	GG2/0-4/0M	MEDIUM	27-1/2"
9703-66412	GG2/0-4/0L	LONG	34-1/2"
9703-66415	GG250-350S	SHORT	20-1/2"
9703-66416	GG250-350M	MEDIUM	27-1/2"
9703-66417	GG250-350L	LONG	34-1/2"
9703-66420	GG400-500S	SHORT	20-1/2"
9703-66421	GG400-500M	MEDIUM	27-1/2"
9703-66422	GG400-500L	LONG	34-1/2"
9703-66425	GG600-750S	SHORT	20-1/2"
9703-66426	GG600-750M	MEDIUM	27-1/2"
9703-66427	GG600-750L	LONG	34-1/2"
9703-66430	GG1000S	SHORT	20-1/2"
9703-66431	GG1000M	MEDIUM	27-1/2"
9703-66432	GG1000L	LONG	34-1/2"

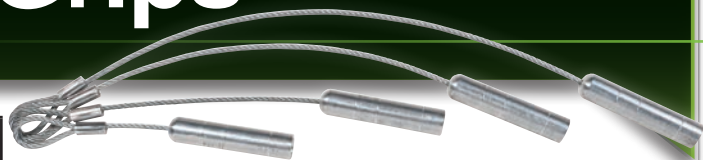

- Maximize contractor productivity by reducing cable pull set-up times:
- FAST, EASY Installation in 2 minutes! Use the Greenlee EK12IDL or HK12ID crimping tool to crimp any size of regular, compressed & compact copper and aluminum cable from 1 AWG to 1000 Kcmil without having to change dies
- VERSATILE - Use with copper and aluminum stranded cables (both regular, compressed and compact stranded).
- ONLY 6 GRIPS NEEDED to cover cable sizes from 1 AWG through 1000 Kcmil
- PARALLEL UP TO 5 CONDUCTORS on the same reel with no overlap



**USA: 1-877-GO ALTEC
(1-877-462-5832)**

www.alteconnect.com

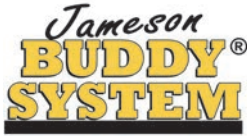

Non-Conductive Fiberglass Conduit Rodders Long Distance Cable Runs

Jameson's non-conductive fiberglass conduit rodders offer a winning combination of strength, flexibility and safety. Whether you are running long distance copper, coax or fiber optic cable to pushing a sonde through conduit or pipe, Jameson has a Buddy® to help you do the job.

Easy Buddy® Conduit Rodder

- Rod or fish conduit 1-2"
 - 4" bend radius; 400-lb pull strength
 - Handles tight turns & long runs
 - Drag brake controls payout
 - Rod marked every 5'
- 28.5" X 24" X 11"



Good Buddy® Conduit Rodder

- Rod or fish conduit 2-4"
- 7" bend radius; 1,000-lb pull strength
- Manhole-to-riser, cable vaults, large conduit runs.
- Drag brake
- Rod marked every 5'



Good Buddy
Detach or fold frame for transport into confined areas



Good Buddy II
Increased rod length for longer runs

Big Buddy® Conduit Rodder

- Rod or fish conduit 4" or larger
 - 10" bend radius; 1,400-lb pull strength
 - Manhole-to-manhole or long run cable pulls
 - Operates vertically or horizontally
 - Drag brake controls payout
 - Rod marked every 5'
- 47.5" X 44" X 20"



Altec P/N	Jameson Part	Description
9702-57150	6-14-300M	1/4" X 300' Easy Buddy
9702-03577	9A-25-400M	3/8" X 400' Good Buddy
9701-92885	11A-25-600M	3/8" X 600' Good Buddy II
9702-46842	11-38-1000M	1/2" X 1,000' Big Buddy

Additional lengths available upon request

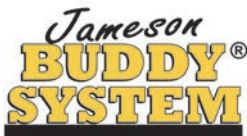

Non-Conductive Fiberglass Fish Tapes Inside Wiring

The round, flexible rod slides easily over wires in occupied conduit. With exceptional bending strength for maneuvering tight turns, this non-conductive fish tape will not kink.

Little Buddy® Fish Tape

- Fish conduit 3/4" to 1-1/2"
- 2.5" bending radius; 200-lb pull strength
- Home drops from hand-hole box to building; inside/outside conduit drops
- Operates vertically or horizontally
- Drag brake controls payout
- 22" X 17" X 7"



Wee Buddy® Fish Tape

- Fish conduit as small as 1/2" diameter
 - 1.5" bending radius; 200-lb pull strength
 - Inside wiring in occupied conduit
 - Easy-grip canister; snap-on accessory kit
- 12.5" X 12.5" X 2"



Altec P/N	Jameson Part	Description
9701-59287	8-18-150K	1/8" X 150' Wee Buddy with Kit
9702-46843	10-316-200	3/16" X 200' Little Buddy

Detectable Rodders Trace Underground Pipe Before Digging



The Duct Hunter™ features a copper trace wire in the rod to trace or map underground conduit or pipe without digging or trenching. The copper wire is energized with an electromagnetic signal detectable above ground with a hand-held signal receiver.

- Trace to depths up to 10'
- Locate sewer laterals or any other type pipe
- Rigid frame and wheel construction
- Rod's ferrule attaches to sonde, roller guide or pulling eye
- Accessory kit included
- 5/16" Rod has 6" Bend Radius
- 7/16" Rod has 9" Bend Radius

Altec P/N	DUCT HUNTER	Outside Rod Diameter	Rod Length	Recommended Conduit Size
9701-59296	12-516-300	5/16"	300'	2" - 4"
9702-69658	12A-516-500	5/16"	500'	2" - 4"
9702-04510	13-716-800	7/16"	800'	4" or Larger
9702-04511	13-716-1000	7/16"	1000'	4" or Larger



- Trace or map inside smaller conduit or pipe (1/2" - 4" diameter).
- Locate fiber optic cables in pvc pipe without tracer wire.
- Longer lengths effective in smaller diameter pipes or conduit.
- Ideal for plumbing applications.
- Handle and lightweight frame for easy transport
- End ferrule has standard thread of 1/4-20
- 3/16" rod has 2.5" bend radius
- Dimensions: 22" X 17" X 7"



Altec P/N	MINI DUCT HUNTER	Outside Rod Diameter	Rod Length	Recommended Conduit Size
9702-03579	15-316-150	3/16"	150'	1/2" - 4"
9702-03582	15-316-300	3/16"	300'	1/2" - 4"

Cable and Pipe Locators



Cable and Pipe Signal Receiver with Push Button Depth
P/N 9706-37201 17-300R

The 17-300R has an ergonomic design for one-hand operation and highly visible display. Features depth indication with push of a button and back-lit LCD display.

Wand Signal Receiver
P/N 9706-37202 17-100R

Compact, lightweight locator allows for easy one-hand operation. The LCD display and function keys are conveniently located on the wand and easy to operate.

Transmitter
P/N 9706-37203 17-500T

Digital transmitter energizes conductive paths and supports Jameson's receivers. Includes low frequencies for direct connect long runs, higher frequencies for tracing Duct Hunter™ rod in plastic pipes or inductive modes.





Electric Axial Ventilator - Plastic



- Indestructible rotomolded plastic housing makes it extremely durable and weather resistant
- Lightweight design for portability; only 14 lbs.
- Accepts any 8" diameter ventilation hose
- Dust and fume abatement
- Output: 1,128 cfm
- Power specifications: 115VAC, 3

amps, 1/3 HP sealed motor
 • Includes built in handle for easy transport
P/N 9000-00362 Mopeco MEB115P

Electric Axial Ventilator - Metal



- Compact design of this lightweight axial ventilator makes it a good choice for confined space ventilation
- Spun steel housing improves output
- Accepts any 8" diameter ventilation hose
- Only 16" long and 16 lbs.
- Rugged steel construction
- Output: 1,373 cfm

• Power Specifications: 115VAC, 3 amps, 1/3 HP sealed motor
P/N 9000-00361 Mopeco MEB115M

Gas-Powered Centrifugal Ventilator

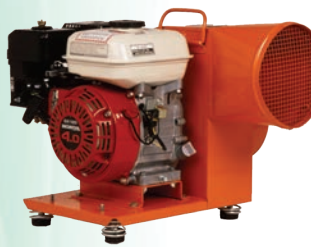

- Gas-powered, these ventilators are ideal for exhausting unwanted air or supplying fresh ventilation in remote or inaccessible locations
- Designed for high-volume ventilation
- Quality at a competitive price
- 8" inlet and outlet

• Compact and lightweight - Only 53 lbs.
 • Vibration absorbing spring-mounted feet
 • **P/N 9000-00373** features a Briggs & Stratton 3.5 HP engine
 • **P/N 9000-00374** features a Honda 4 HP engine
 • **P/N 9000-00375** features a Honda 5 HP engine
 • Output: 1,350 cfm
 • Rugged construction with a 10 gallon steel base and a powder coated steel housing

P/N 9000-00373 Mopeco MVBGE - Briggs & Stratton 3.5 HP Engine
P/N 9000-00374 Mopeco MVBGEH - Honda 4 HP Engine
P/N 9000-00375 Mopeco MVBGEH5 - Honda 5 HP Engine

Electric Axial Ventilator / Hose Combo



- Spun steel housing improves output
- All-In-One Blower, attached 15' hose, and protective canister
- Outside diameter of ventilation hose is 8"
- Weight: 34 lbs.
- Output: 1,373 cfm
- Power: 115VAC, 3 amps, 1/3 HP sealed motor

P/N 9000-00364 Puregas MEBHP15

Electric Centrifugal Ventilator



- Use it to exhaust unwanted air or to supply fresh ventilation
- Provides smooth, quiet operation
- Built-in 10 amp breaker
- Output: 1,250 cfm
- Weight: 42 lbs.
- 8" inlet and outlet
- 115 VAC, 6 amps, 60 Hz, 1/3 HP motor

• Rugged construction with a 10 gauge steel base and powder-coated steel housing

P/N 9000-00372 Mopeco MVBAC

Hose Ducting



- Belt and buckle end; wire rope end finish
- 4" wear strip
- 10:1 compression ratio
- **P/N 9000-00351, P/N 9000-00352, P/N 9000-00353, and P/N 9000-00354** feature a fabric weight of 13 oz. and are heat resistant up to 185°F
- **P/N 9000-00358, and P/N 9000-00359** feature a fabric weight of 15 oz. and are heat resistant up to 250°F

P/N 9000-00351 Puregas M038384 - 8" Diameter, 15' length
P/N 9000-00352 Puregas M038385 - 8" Diameter, 25' length
P/N 9000-00353 Puregas M038386 - 12" Diameter, 15' length
P/N 9000-00354 Puregas M038387 - 12" Diameter, 25' length
P/N 9000-00358 Puregas M99M1310 - 8" Diameter, 15' length
P/N 9000-00359 Puregas M99M1710 - 8" Diameter, 25' length

Hose Stand -
P/N 9000-00356 Puregas M99M1220 -
Fits hoses up to 8" - 10" width, 25' length

Elbow-Mule™



The Elbow-Mule™ removes seized elbows without applying destructive and dangerous kinetic impact force.

The tool uses a standard shotgun stick, and the legs adjust to fit nearly all elbow configurations. Like a gear puller, the Elbow-Mule™ is the slow and steady solution for even the most stubborn elbows.

P/N 9705-45596	USEP-15-27	15 kV & 27 kV ELBOW-MULE™ WITH STORAGE BAG
P/N 9705-45597	USEP-35	38 kV ELBOW-MULE™ WITH STORAGE BAG

Strip-N-Coil™



The Strip-N-Coil™ quickly twists a concentric neutral on an underground cable (#2 through 750 MCM) cutting the outer insulation. The dual action then twists the remaining neutrals into a tight compact bundle for easy cutting. It can also be used to install or remove bushing inserts.

The Strip-N-Coil™ fits any size drill or a ratchet fitted with a 7/16" socket.

P/N 9703-61570 USCS-001 Strip-N-Coil™ Cable Stripper

URD Wrench



The universal URD wrench is designed for utility field personnel responsible for both electrical and water services.

The URD Wrench features an ANSI penta-head as well as a standard six point 3/4" wrench incorporated on opposite ends of the handle. The stainless steel shaft permits the easy prying of manhole covers and is also great for removing debris from pad gear lock pockets. The shaft end doubles as a flat head screwdriver.

P/N 9702-87632 USUW-001 URD Wrench



Pad Mount Multi-Tool



3/4" Socket
5 Point Penta Socket
9/16" Deep Well Socket
Drag Link Socket

P/N 9703-35350 USMT-001 Pad Mount Multi-Tool

The Pad Mount Multi-Tool combines all the tools needed to access pad gear.

The elongated lug wrench enables a substantial amount of torque to be applied to stubborn fasteners, especially penta-head bolts located near ground level.

Made from chrome plated cold rolled steel.

CABLE TAPE & LUBRICANTS

Polywater J Lubricant



- A high performance, clean, slow-drying, water based gel lubricant
- Provides maximum tension reduction in all types of cable pulling
- UL & CSA listed

- Recommended for long pulls, in a hot environment
- High cling factor and temperature stable
- Dries to form a thin film; retains its slip for months after use
- Compatible with all cables
- Available in cold weather (non-freezing) formula

<u>Regular Grade</u>		<u>Winter Grade</u>	
P/N 9000-99494	1-quart bottle	P/N 9000-99497	1-quart bottle
P/N 9000-99495	1-gallon pail	P/N 9000-99498	1-gallon pail
P/N 9000-99496	5-gallon pail	P/N 9000-99499	5-gallon pail

Polywater F Lubricant



- A high performance, pourable liquid lubricant recommended for outside fiber optic cable pulls
- It also can be used for other types of communications cable, including coaxial and copper pair
- Slow drying; leaves a lubricating film after water-base has evaporated

- Compatible with a broad range of cable jackets, including the polyethylene types
- Easy to pour into innerducts and feeder tubes
- Superior friction reduction for lower tension pulls
- Available in cold weather (non-freezing) formula

<u>Regular Grade</u>		<u>Winter Grade</u>	
P/N 9000-99500	1-quart bottle	P/N 9000-99503	1-quart bottle
P/N 9000-99501	1-gallon jug	P/N 9000-99504	1-gallon jug
P/N 9000-99502	5-gallon pail	P/N 9000-99505	5-gallon pail

UNDERGROUND EQUIPMENT

Heavy Duty Quadrant Block



- A series of 6 cast aluminum sheaves on bronze bearings allow cable to make a gradual 90° turn for easy pulling through a manhole opening
 - Pulling radius of 24.25"
 - Can also be suspended in manhole to provide alignment to duct run
 - 4,800 lbs. cable tension load capacity
- P/N 9000-99552 3"
P/N 9000-99553 4"
P/N 9000-99554 5"

Three Sheave Cable Guide



- The 3 cast aluminum sheaves on bronze bearings allow a gradual 90° turn for easy pulling through a manhole opening
 - With a pulling radius of 24", the cable guide will sit on manhole edge, suspend in manhole, or fit the pulling frame
 - 10,000 lbs. cable tension load capacity
- P/N 9000-99550 6"
P/N 9000-99551 8"

Cable Feeding Guide

- This cable feeding guide plugs into conduit in manhole wall, guiding cable safely into the conduit regardless of the pulling angle



<u>Part Number</u>	<u>Size</u>	<u>Load Capacity</u>
9000-99542	1 1/2"	1,500 lbs.
9000-99543	2"	2,600 lbs.
9000-99544	2 1/2"	2,600 lbs.
9000-99545	3"	4,800 lbs.
9000-99546	3 1/2"	4,800 lbs.
9000-99547	4"	6,500 lbs.
9000-99548	5"	6,500 lbs.
9000-99549	6"	6,500 lbs.

Support Bar

- Steel support bar is used to support quadrant blocks or cable guides at street level
 - Dimensions: 1 1/4" x 4"
- P/N 9000-99584



Rope To Rope Grip Clevis

- Combinations of sheaves and pins allow the following connections:
 - 3/4" diameter rope to 3/4" diameter rope
 - Rope to forged eye pulling grip
 - Rope to flexible eye pulling grip
 - Forged eye pulling grip to forged eye pulling grip
 - Versatile clevis provides efficient link for several applications
 - All-steel construction with 10,000 lbs. load capacity
- P/N 9000-99555



Manhole Ladders



- Mar-resistant, vinyl coated aluminum hoop end caps for removing ladder from manhole
 - 3' replaceable plastic sleeves to avoid manhole rim damage to rail
 - Slip-resistant Traction-Tred® round rungs
 - Combination rail shield and shoe protects bottom of rail from damage
 - Yellow, electrically non-conductive side rails
- P/N 9000-99556 8'
P/N 9000-99557 10'
P/N 9000-99558 12'
P/N 9000-99559 14'
P/N 9000-99560 16'

Hose Stands

- Models fit Hoses up to 25' length and 12" diameter
 - Rugged steel construction with a powder coated finish
- P/N 9000-00356 Mopeco M99M1220 - Fits hoses up to 25' length & 8" - 10" width
P/N 9000-00357 Mopeco M99M1220X - Fits hoses up to 25' length & up to 12" width



Manhole Cover Hook

- A simple tool for prying loose conventional manhole covers
- Made from octagon plated tool steel that's been specially hardened to prevent bending



For actual removal of a cover please use one of our Manhole Cover Lifters.

P/N 9000-08172



Manhole Access Tools

Manhole Guard Rail



- Helps protect field crews when working in and around manhole vaults
- Folds into a compact 2 1/2" x 33 1/4" rectangle, yet opens easily into a large 32" wide by 32" deep by 42" high cube
- Features two "D" rings welded to the frame for attaching our Spicer's Combination Tent (P/N 9000-70229)
- The guard is also compatible with GMP's Umbrella Tent (P/N 9000-17020)

P/N 9000-06867 06867

Manhole Cover Lifter



- Simplifies the removal and replacement of typical Telephone manhole covers while decreasing the strain on the user
- Long handle provides useful leverage when removing and replacing manhole covers
- Made of an all-steel handle, sleeve, shank, foot and heat-treated alloy steel hook
- The open end of the hook can be locked inside the handle as an added safety feature when not being used

P/N 9000-01368 01368 Manhole Cover Lifter

P/N 9701-76856 13681 Manhole Cover Lifter w/spiked foot

Manhole Cover Hook



- For prying loose conventional manhole covers
- Made from octagon plated tool steel that's been specially hardened to prevent bending

For actual removal of a cover please use one of our Manhole Cover Lifters.

P/N 9000-08172

Utility Manhole Cover Lifter



- Designed for use with a wide variety of covers
- The plated steel tubular body has been made thicker for the typically heavier electric utility manhole covers
- Multiple hooks or "keys" are available to be placed on the shackle at the end of the lifter's galvanized chain, allowing one tool to remove multiple cover types

Part Number	GMP	Lifter	Small	Medium	Large
		70066	J-Hook	L-Hook	J-Hook
P/N 9000-70151	70151	X	X	X	
P/N 9000-70152	70152		X		
P/N 9000-70153	70153	X		X	
P/N 9000-70154	70154	X			X
P/N 9000-70369	70155	X	X	X	
P/N 9000-70156	70156		X		X
P/N 9000-70157	70157	X	X	X	X



Small J-Hook



Medium L-Hook



Large J-Hook

Duct Cleaning, Proofing, & Rodding

Stiff Spine Conduit Cleaners



- Cleans stubborn foreign matter from a partially obstructed conduit
- Oil tempered, spring steel bristles are looped through a mounting plate, providing extreme durability and resistance to loss
- Hundreds of cutting edges line each side of the cleaner for thorough cleaning action throughout the conduit in either direction

Part Number	GMP	Conduit ID	Body Length	Work Load Limit
9000-70407	10152	2"	4"	1250 lbs.
9000-70408	10153	2.5"	4"	1250 lbs.
9000-70409	10154	3"	5.25"	1250 lbs.
9000-70410	10155	3.5"	5.25"	1250 lbs.
9000-70411	10156	4"	5.25"	1250 lbs.
9000-70412	10157	5"	5.25"	1250 lbs.
9000-70413	10158	6"	5.25"	1250 lbs.

GMP Stiff Spine Conduit Brushes



- Help clean foreign matter in a lightly obstructed conduit before placing cable
- Hundreds of cutting edges line each side of the brush, so that you'll get cleaning in either direction
- Available in ranges of sizes for your different cleaning operations

Part Number	GMP	Conduit ID	Weight	Work Load Limit
9000-17091	17091	2"	3 lbs.	600 lbs.
9000-00319	17025	2.5"	3 lbs.	600 lbs.
9000-17092	17092	3"	4.5 lbs.	600 lbs.
9000-17093	17093	3.5"	6 lbs.	600 lbs.
9000-17094	17094	4"	6 lbs.	600 lbs.
9000-00320	17050	5"	6.5 lbs.	600 lbs.

Please contact your Altec Supply Account Manager for more information regarding quality General Machine products.

Duct Cleaning, Proofing, & Rodding

GMP Rubber Duct Swabs



- Flexible cable is suitable for tight bends
- Rubber Duct Swabs are pulled through your duct system after conduit is installed to verify duct integrity, to clean dirt and residue from installation, to provide a clean raceway for ease of cable placement
- Assists in the spreading of lubricant throughout the duct

Long Duct Swabs:

Part Number	GMP	Conduit ID	Weight
9000-00284	10116	2"	2.5 lbs.
9000-00285	10117	3"	4.1 lbs.
9000-00286	10118	3 1/2"	5.8 lbs.
9000-00287	10119	4"	6.8 lbs.
9000-00288	10120	5"	
9000-00289	10121	6"	13 lbs.
9000-00290	10122	8"	22 lbs.

Short Duct Swabs:

Part Number	GMP	Conduit ID	Weight
9000-00291	10123	2"	1.25 lbs.
9000-00293	10124	2 1/2"	1.45 lbs.
9000-00294	10125	3"	1.75 lbs.
9000-00313	10126	3 1/2"	2.24 lbs.
9000-00314	10127	4"	2.71 lbs.
9000-00315	10128	5"	3.53 lbs.
9000-00316	10129	6"	4.62 lbs.
9000-00317	10130	8"	7.93 lbs.

GMP Washer Duct Cleaner



- Cleans conduit less abrasively
- Disks are made from tough leather in graduated sizes for wiping the inside of the conduit
- An alternative to Stiff Spine Cleaners

Part Number	GMP	Conduit ID
9000-10142	10142	2 1/2"
9000-10143	10143	3"
9000-10146	10146	3 1/2"
9000-10144	10144	4"
9000-10145	10145	5"

Aluminum Test Mandrels



- Test Mandrels are pulled through your duct system after conduit is installed to verify duct integrity and to comply with the ovality (roundness) specification the owner may have
- Made from solid aluminum for durability, corrosion resistance
- Cable is suitable for tight bends

Part Number	GMP	Conduit ID	Weight
9000-00277	10109	2"	1.0 lbs.
9000-00278	10110	2 1/2"	1.5 lbs.
9000-00279	10111	3"	2.5 lbs.
9000-00280	10112	3 1/2"	3.5 lbs.
9000-00281	10113	4"	6.5 lbs.
9000-00282	10114	5"	10.5 lbs.
9000-00283	10115	6"	15 lbs.

Powered Duct Rod Pusher



- With GMP's Powered Duct Rod Pusher and a 1/2" GMP Duct Rodder, the job of placing pulling lines or fiber cables just got that much easier with less personnel in old or occupied conduits
- Hydraulically powers GMP 1/2" Duct Rodders in to and out of conduits.
- Pushes and pulls with forces up to 300 lbs.
- Rod speeds up to 130'/min (40 meters/min)
- Accurately measures footage and speed with an electronic monitoring system that works in either direction. The readout can be scaled to feet or meters

- When pulling back, the fiberglass rod is placed directly back onto the cassette
- Features rod access areas for wiping the rod clean during the pull back operation. Also comes with a package of rod wiper pads (GMP #32290)
- Duct Clamp on the machine, and the specially designed Duct Mounting
- Clamp Assembly (GMP #32221) provided on the rodder cassette, help stabilize both pieces of equipment during use.
- Comes with a gasoline driven power pack and hoses
- Pusher is mounted on a lightweight, anti-corrosion treated, tubular-steel frame that can be tilted at a 30-degree angle to the manhole to reduce initial bending of the fiberglass rod
- Must order 1/2" Duct Rodder Separately. Also, user must provide length of 1-1/4" innerduct between Rod Pusher and Rodder Cassette, and another length of 1-1/4" innerduct between the pusher and the duct to be rodDED

P/N 9702-16417 89004 Calibration in Feet

Please contact your Altec Supply Account Manager for more information regarding quality General Machine products.

Duct Cleaning, Proofing, & Rodding

GMP Duct Rodders



- Fundamentally essential tools for underground tasks such as cleaning and locating ducts, threading lines or pulling cables
- Come equipped with a male threaded end fitting and tapered head on the leading end and a female threaded fitting on the back end
- Carriers are made of tubular steel alloy and are powder coated or electro-galvanized for corrosion resistance; larger diameter carriers have inboard wheels for easier

transport at the jobsite. Each carrier is fitted with a hand-operated brake to control payout

- Light weight, durable and corrosion resistant. The rod is coated with a tough UV stabilized safety orange polypropylene and are not affected by water
- They will not soften or lose tensile strength in hot weather, nor become brittle under cold conditions.
- Each Duct Rodder Frame assists the payout/pay-in of the rod material by using an eyebolt with a nylon bushing. The bushing is designed to protect the duct rod from abrasion and premature wear

Nominal Size	End Fitting Threads	Rated Tensile Strength	Rated Pull Strength	Miniumum Bend Radius
1/4"	5/16-18	6,000 lbs.	500 lbs.	7.4"
3/8"	3/8-16	10,000 lbs.	1,400 lbs.	9"
1/2"	3/8-16	21,000 lbs.	1,800 lbs.	18"

1/4" DUCT RODDERS:

Part Number	GMP	Size
P/N 9000-70370	89202	1/4" x 100'
P/N 9000-70371	89204	1/4" x 200'
P/N 9000-70372	89206	1/4" x 300'
P/N 9000-70373	89208	1/4" x 400'
P/N 9000-70374	89210	1/4" x 500'

3/8" DUCT RODDERS:

Part Number	GMP	Size
P/N 9000-70375	89222	3/8" x 200'
P/N 9000-70376	89224	3/8" x 300'
P/N 9000-70377	89226	3/8" x 400'
P/N 9000-70378	89228	3/8" x 500'
P/N 9000-70379	89230	3/8" x 600'
P/N 9000-70381	89232	3/8" x 700'
P/N 9000-70382	89234	3/8" x 800'
P/N 9000-70383	89236	3/8" x 900'
P/N 9000-70384	89238	3/8" x 1000'
P/N 9000-70385	89240	3/8" x 1100'
P/N 9000-70386	89242	3/8" x 1200'

1/2" DUCT RODDERS:

Part Number	GMP	Size
P/N 9000-70387	89252	1/2" x 200'
P/N 9000-70388	89254	1/2" x 300'
P/N 9000-70389	89256	1/2" x 400'
P/N 9000-70390	89258	1/2" x 500'
P/N 9000-70391	89260	1/2" x 600'
P/N 9000-70392	89262	1/2" x 700'
P/N 9000-70393	89264	1/2" x 800'
P/N 9000-70394	89266	1/2" x 900'
P/N 9000-70395	89268	1/2" x 1000'
P/N 9000-70396	89270	1/2" x 1100'
P/N 9000-70397	89272	1/2" x 1200'

Cable Pulling & Removal Equipment

Control Valve



- Utilizing a ball valve with a safety locking lever, the Control Valve allows control of air flow
- Equipped with a Chicago fitting for connecting to the air supply; also features a quick disconnect fitting at the end for attachment of sealoffs

- Comes standard with a solid plug in lieu of rope adapter for pressurizing ducts

P/N 9702-16419 89801

Rope Adapter



- Allows for a wide range of rope diameters to be used with the above control valve

P/N 9702-16420 29448 3/16"
 P/N 9702-16444 29446 1/4"
 P/N 9702-16445 29447 3/8"

Please contact your Altec Supply Account Manager for more information regarding quality General Machine products.

Cable Pulling & Removal Equipment

Innerduct Seal-Off



- Featuring quick disconnects, these insert into the innerduct and twists tight for seal, utilizing the same Buttress thread as our Pulling Eyes

P/N 9702-16446 89804 Duct Seal-off 1"
 P/N 9702-16447 89805 Duct Seal-off 1 1/4"
 P/N 9702-16453 89806 Duct Seal-off 1 1/2"
 P/N 9702-16454 89807 Duct Seal-off 2"

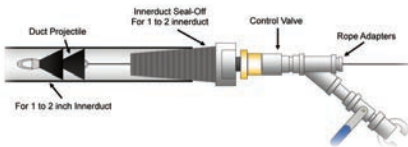

Duct Projectiles



- Constructed of molded rubber cones fastened to a heavy duty metal rod with fastening rings
- Projectile is easily blown through duct with hand blower tool

P/N 9702-16461 70505 Duct Projectile for 1"
 P/N 9702-16462 70506 Duct Projectile for 1 1/4"
 P/N 9702-16463 70508 Duct Projectile for 1 3/8"
 P/N 9702-16464 70509 Innerduct Projectile for 1 1/2"
 P/N 9702-16465 70510 Duct Projectile for 1 1/2"
 P/N 9702-16467 70511 Duct Projectile for 1 7/8"
 P/N 9702-16468 70512 Innerduct Projectile for 2"
 P/N 9702-16469 70513 Duct Projectile for 2 "
 P/N 9702-16470 70514 Duct Projectile for 2 1/2"
 P/N 9702-16471 70515 Duct Projectile for 3"
 P/N 9702-16473 70516 Duct Projectile for 4"
 P/N 9702-16474 70517 Duct Projectile for 5"
 P/N 9702-16475 70518 Duct Projectile for 6"

Construction Chain



- This chain is intended for use in general construction work
- Offered in two link sizes: 5/16" and 1/2"
- The 5/16" link size (P/N 9700-40859) is furnished in a length of 4' 4" and is equipped with an end ring at each end
- The 1/2" link size (P/N 9700-40858) is furnished in a length of 6' and is equipped with a grab hook at one end and an end ring on the other end

P/N 9700-40858 63540 1/2" Link Size
 P/N 9700-40859 63541 5/16" Link Size

Conduit Seal-Off



- Securely fits into a duct with a turn of the wing-nut handle, expanding the two rubber plugs for a firm seal
- 15 psi (1 bar) maximum

P/N 9702-16455 89808 Conduit Seal-off 2"
 P/N 9702-16456 89809 Conduit Seal-off 3"
 P/N 9702-16457 89810 Conduit Seal-off 3 1/2"
 P/N 9702-16458 89811 Conduit Seal-off 4"
 P/N 9702-16459 89812 Conduit Seal-off 4 1/2"
 P/N 9702-16460 89813 Conduit Seal-off 5"

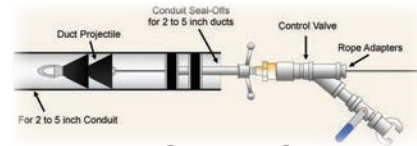

Optional Carry Case for Conduit Seal-offs



- This durable plastic box ensures that your conduit blowing accessories stay together and are protected from damage

P/N 9702-16477 89820

Missile Line Carriers For 2" to 6" Conduit



- Fast blowing and vacuuming of 2" to 6" diameter conduit by low-friction plastic carriers
- Easily removed from conduit if stuck or jammed

P/N 9702-16478 70527 Missile for 2" conduit
 P/N 9702-16479 70528 Missile for 3" conduit
 P/N 9702-16480 70529 Missile for 4" conduit
 P/N 9702-16482 70531 Missile for 5" conduit
 P/N 9702-16616 70532 Missile for 6" conduit

Please contact your Altec Supply Account Manager for more information regarding quality General Machine products.

Cable Pulling & Removal Equipment

5/8" Underground Handlines



- Intended for lowering tools and materials and for setting up cables when doing underground work
- Handlines come equipped with a 1" open hook spliced in one end and a 6' eye splice at the other

P/N 9000-68592	68592	5/8" x 20'
P/N 9000-70368	68597	5/8" x 35'

3/8" Underground Handlines



- Available in lengths of either 50' or 100', this handline is used to raise service drop wires to pole mounted aerial distribution cable plant
- Features a crown splice on one end (without hardware) and a 6" eye splice on the other end

• Ends are served with approximately 1/2" of waxed linen cord

P/N 9000-68593	68593	3/8" x 50'
P/N 9000-68595	68595	3/8" x 100'

GMP Cable Bending Shoes



- These easy-to-install bending shoes protect cables from sharp edges in and around manholes, conduit systems
- Cadmium-plated, 13 gauge steel with a protective polymer coating
- Tie off hole at either end for increased stability during the pulling of cables

- The trough-like steel section is bent into a 75° arc with an extended end for easier insertion into duct. This arc also provides a curved support for bending the cable around

P/N 9000-86570	86570	3"
P/N 9000-86571	86571	3.5"

GMP Ball Bearing Swivels



- Tough swivels, designed to handle higher thrust loads for extra cable safety and faster, straight pulls
- Precision-machined body is made of high quality stainless steel with higher working load ratings than comparably sized swivels available on the market

- These heavy-duty swivels are built with a thrust bearing for tensile load and a radial bearing for bending load

Part Number	GMP	Eye Width	Load Limit	Dia.	Length	Pin
P/N 9000-70136	70136	3/8"	2,250 lbs.	7/8"	3 3/8"	Slot
P/N 9000-70137	70137	17/32"	5,000 lbs.	1 1/4"	4 5/32"	Slot
P/N 9000-70138	70138	9/16"	7,000 lbs.	1 3/8"	4 19/32"	Slot
P/N 9000-70139	70139	11/16"	10,000 lbs.	1 5/8"	5 7/16"	Hex
P/N 9000-70140	70140	1 1/32"	25,000 lbs.	2 1/2"	9 5/8"	Hex

1/2" Utility Handlines



- Intended for general construction use
- 1/2" x 60' handline comes equipped with a crown splice on one end (no hardware) and a 6" eye splice on the other end and waxed linen cord served at both ends for approximately 1/2"

P/N 9000-68596	68596	1/2" x 60'
----------------	-------	------------

Important:

When using handlines, whenever practical, raise and lower tools and materials while standing in a position where the movement of the load to its destination can be observed.

Do not permit the rope to slip through the hands when lowering a load, but use the hand over hand procedure.

Extreme care should be exercised when using a wet handline since it is more difficult to grip the rope securely.

Stand clear as far as possible when raising and lowering heated material, such as solder pots, paraffin pots, etc...ensure that no one is under a load while it is being positioned, raised, or lowered with a handline.

Note: Do not use a wet handline where there is any chance that it may contact an electrical power source except in an emergency and then only when the craftsman is protected by insulated gloves.

Do not store handlines where they will come in contact with ho paraffin or solder pots, furnaces or sharp edged tools. Inspect the rope before the handline is used to ensure that it is in good condition.

GMP Cable Feeding Sheaves



- Cable Feeding Sheaves slide into the end of conduit in a manhole wall, allowing the cable being fed into the conduit to roll smoothly over the sheave from all angles

- The frame is made from steel for durability while the sheave is made from aluminum alloy or Nylatron[®] with self-lubricating bearings
- The sheaves have a split tube for easy removal after cable is installed

Aluminum Alloy Roller Cable Feeding Sheave:

Part Number	GMP	Description
9000-00332	70564	For 3" Duct, Schedule 40
9000-00333	70565	For 4" Duct, Schedule 40
9000-00334	70566	For 4" Duct, Schedule 80
9000-00335	70567	For 5" Duct, Schedule 40

Nylatron[®] Roller Cable Feeding Sheave:

Part Number	GMP	Description
9000-00336	70581	For 3" Duct, Schedule 40
9000-00337	70582	For 4" Duct, Schedule 40
9000-00338	70583	For 4" Duct, Schedule 80
9000-00339	70584	For 5" Duct, Schedule 40
9000-00340	70585	For 6" Duct, Schedule 40
9000-00341	70586	For 6" Duct, Schedule 80

Please contact your Altec Supply Account Manager for more information regarding quality General Machine products.

Cable Pulling & Removal Equipment

UNDERGROUND TOOLS & EQUIPMENT

USA: 1-877-GO ALTEC
(1-877-462-5832)

www.alteconnect.com

GMP Flexible Pulling Grips



- Manufactured from high-tensile, galvanized steel wire that is evenly woven in a single, double or triple wire weave according to pulling tension requirements

Single Weave - Single Flexible Eye

Part Number	GMP	Diameter Range	Min. Breaking Strength	Grip Length
9000-70414	70660	.24" - .51"	1984 lbs.	11.81"
9000-70415	70661	.47" - .75"	3505 lbs.	21.65"
9000-70416	70662	.75" - .98"	4674 lbs.	23.62"
9000-70417	70663	.98" - 1.5"	5644 lbs.	27.56"

Double Weave - Single Flexible Eye

Part Number	GMP	Diameter Range	Min. Breaking Strength	Grip Length
9000-70418	70670	.39" - .79"	4101 lbs.	23.62"
9000-70419	70671	.79" - 1.18"	4974 lbs.	23.62"
9000-70420	70672	1.18" - 1.57"	8148 lbs.	23.62"
9000-70421	70673	1.57" - 1.97"	12103 lbs.	23.62"
9000-70422	70674	1.97" - 2.56"	12103 lbs.	23.62"
9000-70423	70675	2.56" - 3.15"	16138 lbs.	23.62"
9000-70424	70676	3.15" - 3.74"	16138 lbs.	23.62"
9000-70425	70677	3.74" - 4.33"	23398 lbs.	35.43"

Triple Weave - Single Flexible Eye with Shoulders

Part Number	GMP	Diameter Range	Min. Breaking Strength	Grip Length
9000-70426	70680	.24" - .51"	4960 lbs.	25.59"
9000-70427	70681	.47" - .75"	7452 lbs.	32.48"
9000-70428	70682	.75" - .98"	12214 lbs.	40.35"
9000-70429	70683	.98" - 1.26"	21054 lbs.	51.18"
9000-70434	70684	1.26" - 1.5"	25256 lbs.	55.12"

GMP Cable Pulling Harnesses



- This convenient product will allow multiple pulls at one time by attaching 2 or 3 cables or ducts to the puller
- The "legs" are staggered in length so the individual connections are not interfering with each other
- Lead coupler can be easily dismantled to change out or add another leg
- Each leg is marked with load capacity and they are pull tested to 3 times that rating (based on equal pull on all cables, horizontal pull only)
- Manufactured from aircraft quality wire rope
- Other sling configurations are available upon request

Part Number	GMP	Max. Harness Width	Safe Working Load	Wire Rope Diameter
9000-70298	70298	2 1/4"	2,000 lbs.	1/8"
9000-70299	70299	3 1/8"	5,800 lbs.	1/4"
9000-70300	70300	3 1/2"	8,400 lbs.	3/8"

GMP Interduct Pulling Eyes



- Rugged chrome-plated steel pulling eyes allow innerduct placement to become a faster, safer operation
- Easy insertion by rotating the pulling eye into the innerduct allows the threads to make the connection
- A convenient hole in the threaded end of the pulling eye body is used to tie off the innerduct pulling line or tape keeping it from being lost during the pulling operation
- Eyes with swivel eliminate the need to use a separate swivel between the winch line and innerduct
- The hex portion of the pulling eye allows use of a wrench to make the final turns when inserting into innerduct

Without Swivel:	Nominal Duct Diameter	Innerduct Inside Diameter Range	Max Pulling Eye Diameter
Part Number	GMP		
9000-60510	60510	1" & 1 1/8"	1.5"
9000-60512	60512	1 1/4" & 1 3/8"	1.75"
9000-60515	60515	1 1/2"	2.0"
9000-60520	60520	2"	2.5"

With Swivel:	Nominal Duct Diameter	Innerduct Inside Diameter Range	Max Pulling Eye Diameter
Part Number	GMP		
9000-00321	61510	1" & 1 1/8"	1.5"
9000-00322	61512	1 1/4" & 1 3/8"	1.75"
9000-00323	61515	1 1/2"	2.0"
9000-00324	61520	2"	2.5"

GMP B Connecting Links



- These time-tested, split "sister hooks" or "figure-8" links let you join two pulling lines together, and consist of two E-shaped, forged steel parts held together with a metal pin
- Swivel the two halves open to insert the looped end of the each pulling line, then close and secure the link with a few turns of 2" friction tape around the center

Part Number	GMP	Size	Width	Length	Eye Dia.	Safe Load
9000-80771	80771	1/4"	1 5/16"	1 7/8"	3/8"	1,000 lbs.
9000-80773	80773	3/8"	1 5/16"	2 9/16"	1/2"	1,000 lbs.
9000-80775	80775	1/2"	1 5/8"	3 3/4"	5/8"	1,000 lbs.
9000-80777	80777	3/4"	2 1/2"	5"	15/16"	1,000 lbs.
9000-80779	80779	1"	3 3/4"	6 1/2"	1 1/4"	1,000 lbs.

GMP Cable Bending Tool



- Easily bends up to 3 1/2" diameter cable into almost any shape
- The best cable bender to have whether you're setting up cables in manholes, making bends, straightening cable for sleeve placement during splicing, doing setups, off-sets or straightening in buildings, or even working from an aerial bucket
- The tool is made from zinc plated steel with aluminum saddles
- Seven position handle lets you bend cable easily, even when working in close quarters

P/N 9000-71022 17022

Please contact your Altec Supply Account Manager for more information regarding quality General Machine products.

Cable Pulling & Removal Equipment

GMP Manhole Sheaves



- The Manhole Sheave or “Pittsburgh” is used to guide pulling line or cable over the manhole edge when placing and removing cable in manholes which are equipped with pulling in irons to support a sheave and shackle assembly
- Consists of a reinforced, heat-treated wrought aluminum alloy frame with two

self-lubricating, bronze bushed aluminum sheaves

- The frame also has a hole in each side plate so you can insert a 1 1/4” diameter digging bar parallel to the ground to keep the sheave from being knocked into the manhole
- Overall unit dimensions: 30” long x 12” wide x 22” high
- Standard units are rated at 36,000 lbs.; the 80975 heavy duty 5” model is rated for 45,000 lbs.

P/N 9000-70283	70283	3” Manhole Sheave
P/N 9000-70284	70284	4” Manhole Sheave
P/N 9000-70285	70285	5” Manhole Sheave
P/N 9000-80975	80975	5” Heavy Duty

GMP Cable Feeder Nozzles



- These simple split nozzles provide easy connections between our cable feeders and the conduit entered
- Each nozzle is made from high strength, thin-wall steel for a wider ID that permits use of larger pulling eyes
- Nozzles are available for either round or square conduit while still being compatible

with our round cable feeders

- The nozzles are split for easier removal after the cable has been placed and both halves are marked with the nozzle size
- The nozzles are available for straight connections (a 4” cable feeder going into a 4” conduit) or for reduced connections (a 4” cable feeder going into a 3” conduit)

Part Number	GMP	Size	Conduit	Conduit Shape
9000-60590	60590	4”	3”	Round
9000-60591	60591	4”	3 1/4”	Round
9000-60592	60592	4”	3 1/4”	Square
9000-60593	60593	4”	3 1/2”	Round
9000-60584	60584	4”	3 1/2”	Square
9000-60596	60596	4”	4”	Round
9000-60597	60597	4”	4”	Square
9000-70009	70009	5”	3”	Round
9000-70008	70008	5”	3 1/4”	Round
9000-70007	70007	5”	3 1/2”	Round
9000-70006	70006	5”	4”	Round
9000-60599	60599	5”	5”	Round
9000-70005	70005	6”	3”	Round
9000-70004	70004	6”	3 1/4”	Round
9000-70003	70003	6”	3 1/2”	Round
9000-70002	70002	6”	4”	Round
9000-70001	70001	6”	5”	Round
9000-60598	60598	6”	6”	Round

Note: Please state required size if not listed above.

GMP Quadrant Blocks



- Used to guide the pulling line or cable during underground cable placement or removal
- Consists of six cast aluminum sheaves supported in an aluminum frame to provide a bending radius of 24”
- Each sheave is housed in a sturdy aluminum housing and mounted on a self lubricating bushing for smooth movement and a long, maintenance-free life
- Each side plate has holes to insert a 1 1/4” digging bar to keep the block from being knocked into the manhole
- Can also be used with a cable sheave shackle to suspend in the manhole as an alternative method of use

Part Number	GMP	Cable Size	Weight
9000-84453	84453	3”	60 lbs.
9000-84454	84454	4”	75 lbs.
9000-84455	84455	5”	90 lbs.

GMP Split Cable Feeders

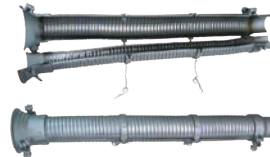

- Same tough construction as our standard feeders with the added benefit of dividing in half for fast, easy removal without needing an end of the cable
- Style of feeder is ideal for pre-connected cables to avoid having to cut and splice cable to remove the feeder
- Excellent for particularly long runs of cable allowing “figure-8 types” of installation
- All exposed edges of both the 90” main split feeder and 36” extension split feeder have a protective plastic coating protecting the cable and user
- The series of latches allows for easy opening and closing of both the body and ends of the feeders

P/N 9000-88830	88830	4” x 90” Main
P/N 9000-88831	88831	4” x 36” Ext.

GMP Cable Feeders



- Solid feeders provide increased cable protection no matter how deep the manhole is and an easy way to apply lubricant to the cable as it passes through the feeder
- Made from flexible spring steel hose
- Both the main section and extension section come with a bronze bell mouth welded to one end
- The main section also has a connecting sleeve welded to the other end, while the extension section has a reducer welded to its other end to fit into the bell mouth of either the main Section or another extension section
- The ability to add extension sections allows a user to make any length of hose required

9000-60580	60580	4” x 90” Main Cable Feeder
9000-60581	60581	4” x 43 1/2” Extension Cable Feeder
9000-60583	60583	4” Main Cable Feeder *
9000-60582	60582	4” Extension Cable Feeder *
9000-60585	60585	5” Main Cable Feeder *
9000-60600	60600	5” Extension Cable Feeder *
9000-60587	60587	6” Main Cable Feeder *
9000-60586	60586	6” Extension Cable Feeder *

Please contact your Altec Supply Account Manager for more information regarding quality General Machine products. *

Customer Specified Length

499

Cable Pulling & Removal Equipment

UNDERGROUND TOOLS & EQUIPMENT

USA: 1-877-GO ALTEC (1-877-462-5832)

www.alteconnect.com

GMP Cable Sheaves

- Used in placing and removing underground cables
- Constructed from high strength aluminum alloy, and has self lubricating bushings for long, maintenance free lives
- All hole sizes are 1 3/8" diameter for 1 5/16" pin
- These units are available in 11", 20", and 26 1/2" diameter, and may be purchased for maximum 3", 4", or 5" cables

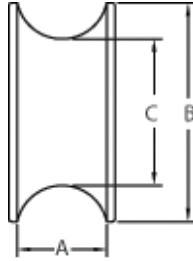

P/N	GMP	A	B	C	Weight
9000-71723	71723	3"	11"	8 1/2"	15 lbs.
9000-71726	71726	4"	11"	7 7/8"	20 lbs.
9000-71729	71729	5"	11"	6 7/8"	25 lbs.
9000-71722	71722	3"	20"	17 1/2"	32 lbs.
9000-71725	71725	4"	20"	16"	36 lbs.
9000-71728	71728	5"	20"	16 1/2"	40 lbs.
9000-71721	71721	3"	26 1/2"	24"	38 lbs.
9000-71724	71724	4"	26 1/2"	22 1/2"	44 lbs.
9000-71727	71727	5"	26 1/2"	23"	56 lbs.

GMP Jamb Skid



- Supports quadrant blocks and sheaves when pulling cable through underground conduit
- Lightweight, constructed primarily of aluminum
- Includes (2) 1 5/16" diameter locking pins to lock the jamb skid height and secure the sheave or quadrant block
- Accepts all GMP sheaves and quadrant blocks with widths up to 7"
- Includes a base unit to accept the upper extensions

P/N 9000-70435	70640	48" - 85"; Includes 43" Extension
P/N 9000-70436	70643	84" - 121"; Includes 76" Extension
P/N 9000-70437	70646	114" - 151"; Includes 109" Extension
P/N 9000-70438	31356	Optional Extension for P/N 9000-70436 or P/N 9000-70437 to 48" - 85"
P/N 9000-70439	31357	Optional Extension for P/N 9000-70435 or P/N 9000-70437 to 84" - 121"
P/N 9000-70440	31358	Optional Extension for P/N 9000-70435 or P/N 9000-70436 to 114" - 151"

GMP Cable Sheave Shackle



- Used for supporting a cable sheave or quadrant block in place at a manhole equipped with pulling-in irons
- Contains a two part clevis made of high strength structural steel, with two sets of sheave pin holes 1 3/8" diameter for accommodating either a cable sheave or quadrant block
- Forged steel hook attaches to the pulling in irons with a standard 1/2" x 6" construction chain, while the support half has a shoulder eyebolt so you can tie it off to a support rope over the manhole
- Will accommodate any 11", 20", or 26 1/2" cable sheave with a 1 3/8" hole size for 3", 4" or 5" cable
- Each shackle includes a 1 5/16" diameter sheave pin and can withstand working loads up to 10,000 lbs.

P/N 9000-71643	71643	3" Cable Size
P/N 9000-71644	71644	4" Cable Size
P/N 9000-71645	71645	5" Cable Size

GMP Pulling Frames



- Used as a guide for the pulling line and cable when placing and removing cable in manholes that are not equipped with pulling irons
- 12' 6" frame is designed for use in manholes up to 11' 6" deep; 15' frame can be used in deeper manholes
- Each frame consists of two 6", high structural aluminum channels bolted back to back
- Sheave pin holes are at 6" centers; individual sheaves can be easily loaded or removed
- Two 1 5/16" diameter sheave pins come with each frame; the C pulling frame is used to support Cable Sheaves or the B operations

Part Number	GMP	Sheave Size
P/N 9000-71710	71710	3" x 12' 6"
P/N 9000-71711	71711	4" x 12' 6"
P/N 9000-71712	71712	5" x 12' 6"
P/N 9000-71713	71713	3" x 15'
P/N 9000-71714	71714	4" x 15'
P/N 9000-71715	71715	5" x 15'

Please contact your Altec Supply Account Manager for more information regarding quality General Machine products.

Fiber Optic Cable Deployments

GMP Mid-Assist Fiber Optic Capstan



- Lightweight aluminum alloy units mount on a standard 2 7/16" diameter drive shaft with either a bayonet or a cross pin type of connection
- Capstans can be used as end pullers or mid-assist booster pullers that will allow long, straight-through, splice-free pulls
- Offered with a torque limiter between

the drive spindle and the inner hub, factory set at standard 600 lbs. force, but may be calibrated to other torque values, if requested

- Also available with a steel shaft and no torque limiter for no-slip applications with a maximum rated load of 1500 lbs.
- Can also be used with Fiber Optic Cable Blowers in series to place longer lengths of cable without splicing

Part Number	GMP	Diameter	Width	lbs. force
9000-15472	15472	25"	5"	600
9000-15479	15479	25"	5"	1000
9000-15470	15470	25"	5"	N/A
9000-70403	70338	25"	5"	750
9000-70351	70351	32"	7.5"	600
9000-00326	70381	32"	7.5"	750
9000-00327	70471	32"	7.5"	1000
9000-00328	70472	32"	7.5"	N/A
9000-00329	70473	40"	7.5"	600
9000-00330	70475	40"	7.5"	1000
9000-00331	70478	40"	7.5"	N/A

GMP Fiber Optic Pulling Trailer



- Exceed the requirements of installing telecommunication cables, employing a 32" diameter single capstan to provide a controlled force to the pulling rope or tape
- The single capstan allows the winch to be placed at the mid-point of a section to assist in the pull, thus enabling longer pulls to be achieved
- The winch is mounted on a sturdy all-steel fabricated chassis. It is equipped with torsional suspension axles, stabilizing prop legs, a front telescopic jockey wheel and a tow bar with a Lunette Ring
- Rope take-up drum is driven independently by a hydraulic motor

P/N 9000-00342 70605

GMP Hydraulically Limited Cable Puller

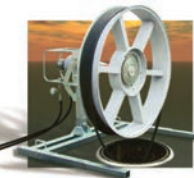

- Designed to offer exceptional value while providing critical speed control and overload protection
- Adjustable pull control, up to 1000 lbs. maximum on a 40" diameter capstan
- Speeds up to 425' per minute at 15 gpm flow
- Control panel with pressure gauge, pressure adjustment knob and directional foot control valve
- Hydraulic hoses come with 1/2" non-spill quick-disconnect fittings for 2500 psi maximum hydraulic source input

P/N 9000-70398 70483 Hydraulically Limited Cable Puller Motor with Self-Support Frame, Foot Control Valve, and (2) Hydraulic Hoses

P/N 9000-70399 70484 Hydraulically Limited Cable Puller Motor with Vehicle Receiver Mount, Support Jack, Foot Control Valve and (2) Hydraulic Hoses

P/N 9000-70401 70486 Hydraulically Limited Cable Puller Motor with Foot Control Valve and (2) Hydraulic Hoses for 2 1/2" Square Socket Mount

P/N 9000-70402 70487 Stanley Hydraulic Power Unit with (2) Hydraulic Hoses, 1/2" diameter x 20'

GMP Fiber Optic Cable Blower



- Safe, fast and effective, even on tough terrain, the "Tornado" cable blowing machine will move fiber optic cable of 0.23" to 1.25" diameter at speeds to 300' per min. into pre-installed innerduct or direct-buried duct
- Accommodates 1" to 2.48" innerduct
- A conversion kit allows the Tornado to place either 12/10 mm or 10/8 mm micro duct into the innerduct
- Comprised of an aluminum air box

- and cable pusher, the "Tornado" uses compressed air to install the cable with or without a missile
- The hydraulically powered, caterpillar belt drive system controls the cable as it is propelled by compressed air into the duct
- An electronic monitoring system provides read-outs of speed and distance, protects cable against duct obstructions, and includes an emergency stop facility

Part Number	GMP	Description
9000-00344	89000	"Tornado" Cable Blowing Machine w/ Hydraulic Power Pack
9000-00345	89174	10/8 mm Micro Duct Conversion Kit
9000-00347	89175	12/10 mm Micro Duct Conversion Kit

Please contact your Altec Supply Account Manager for more information regarding quality General Machine products.

Fiber Optic Cable Deployments

Break-Away Swivels



- Swivels provide an inexpensive fracture point between the pulling line and cable avoiding costly cable damage if the cable's rated pulling capacity is exceeded
- Available in two diameters; 7/8", made from high quality aluminum and 5/8", made from steel
- The 5/8". size is designed for use

when working with innerduct sizes below 1 5/8" diameter

- The design of the swivels incorporates a replaceable tension bolt that joins the barrel eye and swivel body. The bolt separates when pulling loads on the cable reach +/-5%. The damaged bolt can then be replaced in seconds using an Allen Wrench (included) and screwdriver.
- Swivel and bolt head are color-coded for fast load identification
- GMP uses a steel thrust washer and bushing in the larger break-away swivel and four (4) ball bearings in the smaller version; both designs provide smooth rotation under load and help to keep twisting forces from reaching the cable.

Aluminum 7/8" Diameter Break-Away Swivel

Part Number	GMP	Breaking Point (Lbs.)	Color Code
9000-53700	53700	340 lbs.	White
9000-53701	53701	450 lbs.	Orange
9000-53702	53702	600 lbs.	Yellow
9000-53703	53703	800 lbs.	Blue
9000-53704	53704	1,000 lbs.	Green
9000-53705	53705	1,200 lbs.	Red

Steel 5/8" Diameter Break-Away Swivel

Part Number	GMP	Breaking Point (Lbs.)	Color Code
9000-71399	71399	200 lbs.	Orange/White
9000-71400	71400	220 lbs.	Red/White
9000-71401	71401	295 lbs.	Green/White
9000-71402	71402	340 lbs.	White
9000-71403	71403	400 lbs.	Blue/White
9000-71404	71404	420 lbs.	Yellow/White
9000-71405	71405	435 lbs.	Violet/White
9000-71406	71406	450 lbs.	Orange
9000-70188	70188	500 lbs.	Violet
9000-71408	71408	600 lbs.	Yellow
9000-70191	70191	700 lbs.	Brown

Fiber Optic Sheave & Shackle

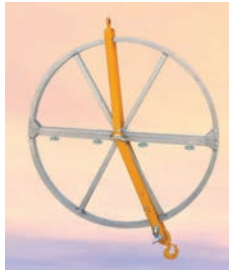

- This new "bicycle wheel", combination is designed to accommodate the special handling needs of pulling fiber optic cable
- One-size shackle
- 32" and 40" sizes are split to accommodate less than 32" diameter manhole
- Lightweight design, aluminum construction with self-lube bearings
- Captivating pins on shackles prevent cable damage when not under tension
- For overhead applications 24" sheave with shackle provides generous bending radius for fiber optic cable up to .6" diameter
- All removable hardware is retained for security

Part Number	GMP	Description
9702-16618	71548	Underground Fiber Optic Shackle (requires Fiber Optic Sheave)
9702-16619	71549	Overhead Fiber Optic Shackle with 24" Fiber Optic Sheave
9702-16620	71550	24" Fiber Optic Sheave
9702-16621	71551	Underground 32" Split Fiber Optic Sheave
9702-16622	71552	Underground 40" Split Fiber Optic Sheave
9702-16623	71554	Overhead Fiber Optic Shackle (Requires Fiber Optic Sheave)
9702-16624	71560	Underground 24" Fiber Optic Sheave & Shackle Assembly - working-load: 2,000 lbs.
9702-16625	71561	Underground 32" Split Fiber Optic Sheave & Shackle Assembly - working-load: 1,250 lbs.
9702-16626	71562	Underground 40" Split Fiber Optic Sheave & Shackle Assembly - working-load: 1,250 lbs.

Please contact your Altec Supply Account Manager for more information regarding quality General Machine products.

Winches & Vehicle Accessories

CD 3 Continuous Duty Winch

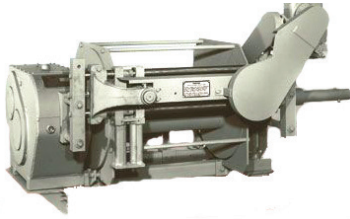

- Designed for the placement or removal of communication cable or electrical conductors, in aerial or underground applications
- Compact design (51.85") for easy mounting
- Helical gears drive the winch
- For ease of removal for service or remounting in a new chassis, welding has been eliminated
- Rated for continuous duty in compliance with SAE J706, and has a bare drum pulling capacity of 24,000 lbs.
- Hydraulically driven Three Speed Transmission provides true "shift-on-the-fly", using the two spool valve supplied
- Full load brake is spring applied and hydraulically released and is designed to hold the rated load up to 24,000 lbs. on a bare drum; the brake is non-directional, meaning you can pull-in or power-out when required without overheating
- Level-wind mechanism for 7/16", 1/2", or 9/16" wire rope (specify exact o.d.), which distributes the wire rope onto the drum in tight, even lays; the level-wind can be supplied in overwind or underwind configuration at no additional charge; the unit is easily converted in the field

P/N 9000-70441 70524

WG Intermittent Duty Winch

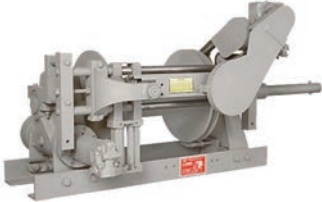

- Ideal for applications requiring intermittent, heavy duty operation
- Ruggedly built to deliver long, trouble-free service life
- 20,000 lbs. pulling capacity (bare drum)
- Level-wind mechanism for 7/16" wire rope
- Wraps the wire rope onto the drum in tight, even layers
- Integral 2 speed hydraulic motor; pneumatically-actuated clutch
- Adjustable full load brake with automatic engagement when drum rotation is reversed
- Hydraulically actuated disc brake controls free-spool payout
- Choose either left or right hand extension shafts (1000 lb. rating)
- Weight is 890 lbs. without wire rope

P/N 9700-35502 70530

7" Aluminum Capstan



- Cast from a high strength aluminum alloy
- Will fit on any 2 7/16" diameter winch extension shaft equipped with a bayonet or pin type mount
- The working surface is 7 1/4" diameter x 8" wide
- The maximum allowable pull is 4000 lbs.

P/N 9000-10727 10727

25,000 lb. Universal Swivel Sheave



- Permits winches to pull wire rope from any angle within the operational limits of a maximum rated winch line pull of 25,000 lbs. force for underground applications and 14,000 lbs. force for overhead applications
- The UV-25 sheave assembly is a ruggedly constructed weldment designed for safety, ease of use, long life, minimum maintenance
- Designed to swivel 360° on anti-friction hardened steel balls
- Accepts wire rope up to 9/16" in diameter
- Constructed from steel plates, the unit features a hardened steel sheave with a roller bearing
- Features guide rollers that when removed allow the passage of the eye of the winch line through the unit
- Torsion springs and hardened steel rollers on the swivel head provide constant wire rope contact
- Can be mounted in many locations, including the tail shelves of utility vehicles
- Easily installed and dismantled from the tail shelf using (2) mounting sockets (P/N 9000-15836) and (2) hardened steel bolts (P/N 9000-17746)

P/N 9000-70202 70202

Capstan Drive



- Gives your mobile hydraulic equipment the capacity to run our line of power reels and capstans
- So, even when your vehicle doesn't have a winch, you can still achieve the benefits of GMP's highly productive cable placing tools using this economical device
- Our Capstan Drive features a Bell standard 2 7/16" bayonet shaft and a highly efficient planetary gear reduction that rotates on roller bearings and is powered by a compact, continuous duty single stage motor
- Features a multi-disc wet brake that's spring applied and hydraulically released is rated for the unit's full pulling load
- Features a built-in bidirectional counterbalance valve to give "feathering" control over the load movement in either direction
- At maximum flow of 15 gpm and operating pressure of 2250 psi, the capstan shaft can achieve 58 rpm and develops 13,000 in. lbs. of torque. That translates into the following line speeds and line pulls:

Device	Line Speed	Line Pull
7" Capstan	106 Ft./min.	3,250 Lbs.
C.R. Reel	304 Ft./min.	1,300 Lbs.
25" Capstan	380 Ft./min.	900* Lbs.
32" Capstan	486 Ft./min.	700* Lbs.

* Line pull limited to 600 lbs. typical clutch setting

P/N 9000-70329 70329

Please contact your Altec Supply Account Manager for more information regarding quality General Machine products.

Reel Handling Equipment

GMP B Cable Reel Jacks



- Two of these heavy-duty jacks can support cable reels weighing up to 12,000 lbs.
- Consists of a steel A-frame, a tee which accepts a 2 1/2" diameter spindle bar, a screw assembly and a three-hole adjusting nut with a detachable 36" lever bar
- Tee of the jack accepts a standard cable reel spindle 2 1/2" in diameter and has a

3/8" vertical locking pin hole in the center

- The height of the jack, from the base to the center of the spindle, ranges from a minimum of 29" to a maximum of 48" when fully extended
- The spindle is 63" long with a 3/8" diameter locking pin hole 4" from each end; the spindle must be ordered separately

P/N 9000-74530 74530

P/N 9000-74531 74531 Spindle

GMP Reel Buck



- A tough, easily maneuvered and portable frame that's ideal for supporting any reel up to 36" wide x 50" diameter
- Two welded, rectangular steel members make up the frame
- Designed for one-person handling
- Frame protected against corrosion
- 1200 lb. load capacity
- 42" long spool bar included

- The foot and handle design holds the main frame up and away from irregular surfaces
- Will accommodate the Corning FlexNap™ cable drums

P/N 9000-00343 71669

GMP Small Cable Reel Jacks



- The small cable reel jack is primarily used for block and building cable and strand reels
- The jack consists of a steel frame, a tee for accepting the spindle and a screw assembly
- The height of the jack, from the base to the center of the spindle ranges from a minimum of 19" to a maximum of 30" when fully extended

- Holes are provided in the base for securing the jacks to planks or lags if required

- The jacks are sold in pairs with a 15" lever bar

- Feature a durable black finish for extra corrosion protection

P/N 9000-66050 66050

P/N 9000-66051 66051 Spindle 1 1/2" x 48"

GMP Reel Caddy



- Large diameter reel caddies
- May be used to support and dispense drop cable quickly and easily
- Lightweight; folds flat for compact storage
- Fabricated from durable steel tubing that's painted for years of dependable service
- Supports reels up to 30" in diameter and easily accommodates Multiport deployment on cardboard or plastic reels

- Quick and simple to setup with one hand

- Supports reels up to 200 lbs. with at least a 1 1/2" spindle diameter

P/N 9701-86307 70403

Miscellaneous Utility Equipment

GMP D Umbrella and Dielectric Umbrella



- Umbrella's tough plastic 68" diameter cover is safety yellow on the top
- A reflective white underside decreases interior heat absorption
- Vinyl-coated, nylon rid-end pockets keep the frame from tearing the cover
- Features self-sealing, waterproofed, waxed stitching and improved construction, using a nylon sleeve and rib retainers for attaching the frame's six collapsible ribs
- Frame's collapsible fiberglass ribs connect at a ring-type lock that slides along the pole as umbrella is opened or closed
- 43" long wooden pole features a male ferrule that may be attached to the 29" extension section for a 6' height
- When working near power lines, choose the dielectric umbrella to eliminate potential sources of electrical shock

P/N 9000-80920 80920 D Umbrella

P/N 9000-70352 70352 Dielectric Umbrella

P/N 9000-28210 28210 Holder (Hardware Not Included)

P/N 9000-71647 71647 Adapter

P/N 9000-80921 80921 Nylon Storage Case

Please contact your Altec Supply Account Manager for more information regarding quality General Machine products.

Miscellaneous Utility Equipment

Splicer's Knife & Scissors Kit



- A favorite of craft professionals everywhere, this kit joins GMP's Splicer's Scissors and Skinning Knife in a single sturdy, belting-quality leather pouch
- The heavy duty pouch is stitched throughout and riveted at all stress points; separate pockets for each tool and a slotted back that will fit any belt up to 2" width

P/N 9000-15471 15471 Kit
 P/N 9000-24470 24470 Pouch Only
 P/N 9000-24471 24471 Splicer's Knife
 P/N 9000-01008 01008 Splicer's Scissors

Knife and Scissors Sharpener



- Sharp cutlery is both easier and safer to use, and you can keep your cutlery at its keenest with this easy-to-use sharpener
 - The two carbide bits in front are for sharpening knives; to sharpen scissors, draw the non-serrated edge of your scissors, along the sharpener's single side bit by resting the sharpener on a flat surface
 - Just draw the sharpener along the blade of your tool three or four times, and the original edge is restored in seconds
 - The built-in finger guard protects your hand
- P/N 9000-15475 15475 Knife and Scissors Sharpener

Overhead Electric Placing Equipment

Cable Pulling Sled



- The Pulling Sled is used for aligning two or three cables in our multiple cable block when pulling overhead cable into position prior to lashing
- Incorporates either a 5000 or 7500 lb. swivel capacity on the front end and three 5000 lb. capacity swivels on the back end
- Generally used with any conventional winching device
- The 22" chain provides both alignment and stability

P/N 9702-16627 70649 Cable Pulling Sled
 P/N 9702-16628 70626 Sled with Swivels

90° 3 Roller Inside Corner

Cable Guide



- Often called the "Banana Bar", this guide consists of a curved steel frame that accommodates five 3 roller cable blocks that clamp to the frame
- Each block can handle up to three 2 1/2" diameter cables
- Cable bending radius of 25"

P/N 9702-16632 71563 Guide, complete with blocks
 P/N 9702-16633 28249 Replacement block only

3 Roller Starter Guide Block



- Used as a starter block during the pulling in of heavy duty cable up to 6" diameter as it is pulled from a stationary or moving cable reel
- Has three rollers that guide the cable with minimal friction
- Cable pulled through the block has a minimum bending radius of 17"
- Designed for use with larger cables up to 6" in diameter, i.e. 750 MCM Tri-Plex Conductors
- Has a heavy duty aluminum frame with stainless hardware
- A 7/8" hex actuates a screw vise to grip the strand and keep the block in a stationary position
- Can be used on strand sizes 3/8" to 9/16"
- Capacity for up to 6" diameter cable and a safe working load of up 2000 lbs.
- After cable and support rings are in place, the block has hinges that open at one side for easy removal

P/N 9702-16636 75268

Rope to Rope Connector



- This connector is used to connect two ropes of up to 7/8" diameter
 - Rated @ 15,000 lbs. max. load, this connector is made entirely from Stainless Steel
 - Available only in the one size since it can also be used for smaller rope sizes
 - 3:1 load safety factor (horizontal pull only)
- P/N 9702-16630 71130

Rope to Swivel Connectors



- These Rope to Swivel Connectors achieve in two products what others do in four
- These Stainless Steel connectors maximize usefulness by catering to the same rope capacity and using different ends to attach to the most popular swivel sizes
- The sheaves run on clevis pins (replacements available)
- 3:1 load safety factor (horizontal pull only)

P/N 9702-16634 71131 Connector, 7,000 lbs. Max Load
 P/N 9702-16635 71132 Connector, 15,000 lbs. Max Load

ADSS FIBER OPTIC CABLE SOLUTIONS TYPICAL INSTALLATION AND TOOLS

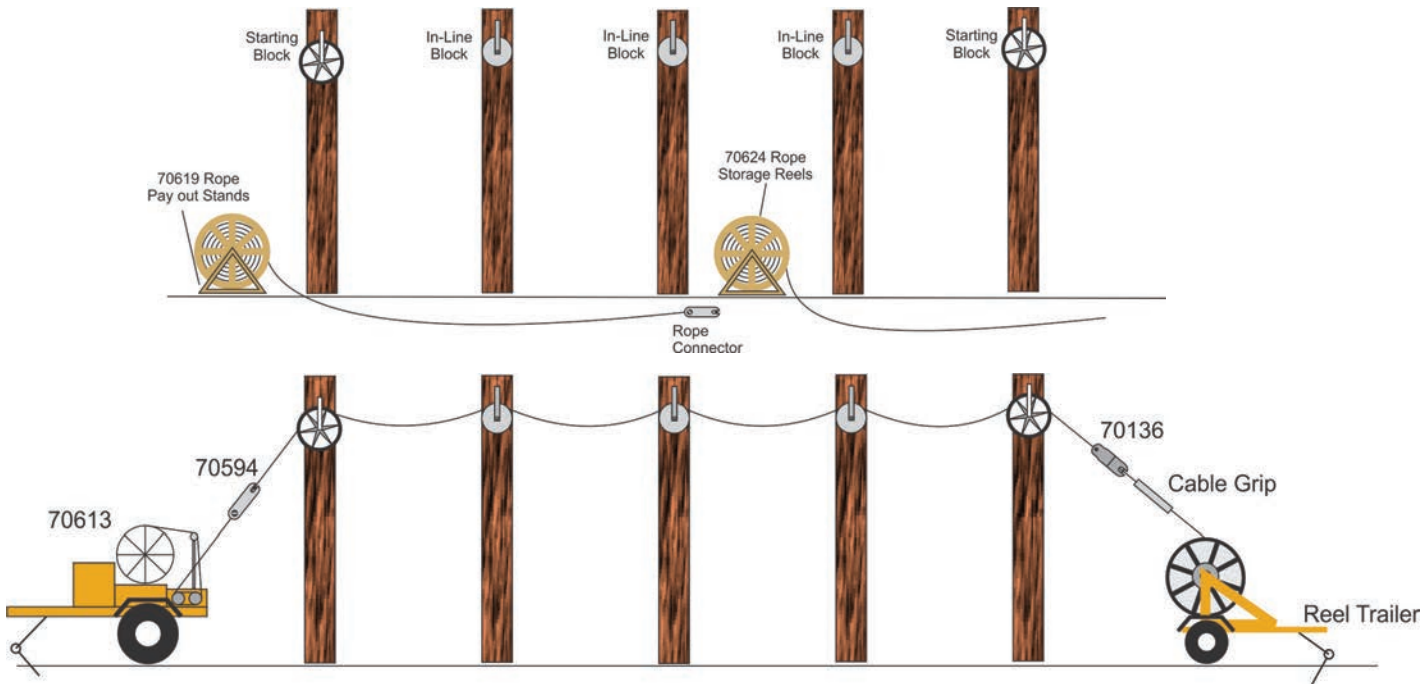

Recommended Installation Equipment



In Line Block

Split side frame and hooks make it easy to use. The side frame incorporates a guide ring to protect the fiber cable. The sheave rides on ball bearings.

O.D.: 7.87"
Groove Width: 2.36"
Root Dia.: 5.4"
Wt.: 8.52 lbs.
W.L.L.: 660 lbs.
P/N 9703-34171
GMP 70615

O.D.: 8.44"
Groove Width: 2.36"
Root Dia.: 6.0"
Wt.: 9.5 lbs.
W.L.L.: 660 lbs.
P/N 9703-34174
GMP 70616



Starting Block

The block has a safety gate and steel side frames. The sheave rides on ball bearings.

O.D.: 11.8"
Groove Width: 1.77"
Root Dia.: 9.64"
Wt.: 15.4 lbs.
W.L.L.: 2646 lbs.
P/N 9703-34130
GMP 70595



Starting Block

The large diameter profiled groove helps protect the cable. The swivel oval eye, cable gate and cable retaining pin make it easy to use. The sheave rides on ball bearings.

O.D.: 18.50"
Groove Width: 2.17"
Root Dia.:
Wt.: 30.8 lbs.
W.L.L.: 5291 lbs.
15.16"
P/N 9703-34209
GMP 70621

O.D.: 26.06"
Groove Width: 2.36"
Root Dia.:
Wt.: 33.1 lbs.
W.L.
23.62"
.L: 5291 lbs.
P/N 9703-34166
GMP 70614



Rope Connector

Rope connectors provide an effective method of joining pulling ropes.

P/N 9703-34123 GMP 70594
W.L.L.: 2200 lbs.



Heavy-Duty Ball Bearing Swivel

These tough stainless steel swivels are designed to handle higher thrust loads for extra cable safety.

Aerial
P/N 9000-70136 70136
W.L.L.: 1350 lbs.



Flexible Pulling Grips

Manufactured from high-tensile, galvanized steel wire that is evenly woven in a triple wire weave, grips are slipped over the outside sheath of a cable. When pulling tension is applied, the grip contracts applying its gripping force to the outside of the cable.

Altec P/N	GMP P/N	Diameter Range	Minimum Breaking	Grip Length
P/N 9000-70427	70681	.47 to .75"	7452 lbs.	32.48"
P/N 9703-34219	70682	.75 to .98"	12214 lbs.	40.35"
P/N 9000-70429	70683	.98 to 1.26"	21054 lbs.	51.18"



Rope Storage Reel with 5/16 x 2000' of Rope

Unique reel design that allows it to be used on both the payout stand and the Cable Pony. Holds up to 2,000' of 5/16" dia. pulling line.

P/N 9703-34212 GMP 70624
W.L.L.: 2200 lbs.



Rope Pay Out Stand

Supports the rope storage reels during the stringing process.

P/N 9703-34177 GMP 70619



Cable Pony Hydraulic ADSS Winch

The GMP Cable Pony winch offers the constant pulling tension of a double capstan drive and the flexibility of a direct drive drum in one machine.
Max. Pulling Capacity: 2200 lbs (1000 kg)
Rope Speed Max.: 130 ft/min (40 meters/min) at capstan

P/N 9703-34131 GMP 70613

Overhead Electric Placing Equipment

UNDERGROUND TOOLS & EQUIPMENT

USA: 1-877-GO ALTEC
(1-877-462-5832)

www.alteconnect.com

G Cable Lasher

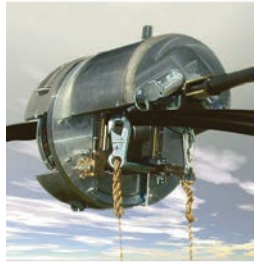

- Lashes any cable from 2 1/2" to 5" diameter, on strand from 11/32" to 3/4" diameters with one or two left lay spiral wrappings of .065" diameter stainless steel wire
- Can be used for new installs or with existing cables in place
- Nominal spacing between wraps is 16 1/2"
- Each lasher includes a 6' bridle rope assembly with snap hooks, an information and operations manual, and a heavy duty storage chest

- P/N 9000-10500 10500 G Cable Lasher Standard
 P/N 9000-10502 10502 G Cable Lasher Modified for 1250' of .045" wire
 P/N 9000-03165 03165 Bridle Rope Assembly only
 P/N 9000-10501 10501 Chest only
 P/N 9000-70190 70190 Towing Lanyard 35 ft. (opt.)

Stainless Steel Lashing Wire



- Used to lash an aerial cable or combination of cables to a supporting strand
- Packaged as 6 coils per carton for ordering convenience
- Available in a 430, 302, and 316 stainless steel alloy
- All lashing wire is wound in a straight hub configuration to fit all the standard GMP lashers

Type 430 Stainless

- Low carbon, 17% chromium wire
- Suitable for general use and in ordinary atmospheric exposure
- Will acquire only a dark surface stain
- Specifically not recommended for use within 25 miles of salt water or industrial operations which emit pollutants

Type 302 Stainless

- 18% chromium, 8% nickel analysis
- Excellent resistance to corrosion from industrial atmospheres
- Higher tensile strength and breaking load are an added benefit
- A .038 in. diameter Type 302 wire provides strength equal to a .045 in. type 430 wire with better ductility (easier bending and unwinding) and better elongation (less chance of wire breakage from stress)

Part Number	GMP	Alloy	Diameter	Ft. Coil	Coil Dia.	Coil Width	Coil Package	Note
P/N 9000-71530	71530	430	.045	1200	5.38"	1.81"	6	1
P/N 9000-71531	71531	430	.065	650			6	
P/N 9000-71532	71532	430	.065	450	5.50"	1.69"	6	2
P/N 9000-71533	71533	302	.045	1200	5.38"	1.81"	6	1
P/N 9000-71534	71534	316	.045	1200	5.38"	1.81"	6	1
P/N 9000-71535	71535	302	.038	1600	5.38"	1.81"	6	1

G Cable Block



- Block is functionally similar to our D Cable Block
- This larger tool can be used with the G Cable Lasher to handle cable up to 5" diameter and features strand hooks to accommodate 3/8 - 3/4" diameter strand
- This heavy duty block is made from 100% heat treated aluminum alloy
- Contains two vertical side rollers in addition to the cable sheave to minimize cable friction during pulling in

P/N 9700-77142 01051

Type 316 Stainless

- Modified 18-10 analysis containing approximately 2.5% molybdenum
- More resistant to the corrosive action of most chemicals, including chlorides and sulfides, than any other wire
- Particularly resistant to pitting and pin hole corrosion of the kind commonly caused by salt spray
- Its use provides the best insurance against failure under the most severe atmospheric conditions

Buying tip:

When estimating the length of lashing wire required for a cable run, add the following amounts to the length of the run for single lashing:

Add:*	For Cables Up to:
5%	1 1/2" diameter
10%	1 1/2" to 3" diameter
20%	Over 3" diameter

* For double lashing, double the quantity

Note:

- 1) Fits standard C2 Lasher, J2 Lasher, and Apollo Lasher
- 2) Fits G Lasher or Modified C2 and J2 Lashers

Overhead Electric Placing Equipment

D Lashing Wire Clamp



- Perfect for temporary and permanent terminations or grounds, this all steel clamp lets you securely attach two lashing wires or #6 ground wire on any size strand from 1/4" to 7/16" diameter

P/N 9000-07886 07886 2-piece 100/Box

3 Sheave Cable Block



- Heavy duty Multiple Sheave Cable Blocks are used to simultaneously support two, three, or four cables prior to lashing to a supporting suspension strand
- 3 sheave multiple cable block can keep up to three 2 1/2" diameter or smaller cables separate until you're ready for lashing to the messenger
- The 3 sheave block is ideal for triplexing cables in the electrical industry; that is

lashing up to three 750 MCM cables together to a supporting strand

- Feature heat treated aluminum alloy frame and sheave, with Oilite bearings on the sheave and steel inserts on the strand hooks for easier movement
- A bi-directional lever operated cam locks the block in place during pulling in, then automatically releases during lashing

P/N 9000-10553 10553

E Lashing Wire Clamp



- Designed for permanent wire terminations, this clamp has the same hardware, construction and clamping range as our D Clamp, but with a one piece stamping formed to let both sides grip the messenger in perfect alignment

P/N 9000-81460 81460 7/16" Opening 1-piece 100/Box

Multi-Roller Overhead Cable Guide



- The Roller Type Aerial Cable Guide is used to guide and straighten cables as they are pulled into a lashing position from a stationary or moving cable reel
- With its three sheaves to guide cable with minimum friction, this is the best tool you can use when handling especially heavy cable, or when using an aerial basket for "drive-off" lashing
- The guide rides along the strand on a roller bearing for smooth movement

- A built in grip prevents back rolling during span transfers
- Also included with the guide is a safety chain to prevent the guide from coming off the strand

P/N 9702-16638 91605* (3) Roller Guides for 4" Cable or bundles to 4"

P/N 9700-74294 91606* (3) Roller Guides for 2 3/4" Cable or bundles to 2 3/4"

* The above cable guides have 2 rollers instead of the rubber grip and they do not require the use of the hitch weldment or hitch field kit

P/N 9000-91604 91604 (3) Roller Overhead Cable Guide for 2 3/4" Cable

P/N 9000-30140 30140 Hitch Weldment for J2 Lashers

P/N 9000-70125 70125** Hitch Field Kit for F, J, J2 Kashers Guide for 2 3/4" Cable

*Only J2 Lashers with Serial #91-0001 or higher are factory ready equipped with a Hitch Weldment. All other J2 Lashers should be retro-fitted with a Hitch Field Kit.



AUGER EQUIPMENT

USA: 1-877-GO ALTEC
(1-877-462-5832)

www.alteconnect.com



COMPLETE MD AUGERS

The following components are included in the complete auger system. Parts are available for replacing worn parts or repairing the auger itself.

Overall Length	104"
Flight Length	60"
Diameters	8" thru 36"
Flight Thickness	5/16"
Dish	9" Cast/Stnd Lug
Hex Hub Connection	2 1/2" or 2 5/8"

MD Boring Head	For 1650 series teeth
Shanks	Size Varies with Diameter of Auger
Pilot Bit	Options Below
Drive Lug	Options Below
Teeth	Options Below
Teeth with Carbide Insert	Options Below

DIRT DRILLING APPLICATIONS

The following are the options available for drilling in dirt conditions. Pengo Fas-N-Lok® dirt teeth do not require the use of Rub-R-Lok, however in some cases Rub-R-Lok may be used for a tighter fit.

ORDINARY DIRT APPLICATIONS	
Pilot Bit	TF-600
Pilot Bit Adapter	PA 183L
Dirt Tooth	1650 (bucket qty. 50)
Dirt Gage Tooth	1652 Gage (bucket qty. 50)
Tooth Holder	1XS, BT-100, WT-50

FROZEN SOIL, LOW IMPACT	
Pilot Bit	FH-205C
Pilot Bit Adapter	PA 183L
Dirt Tooth	1656 (bucket qty. 25)
Carbide Tooth	1658 (bucket qty. 25)
Tooth Holder	1XS, BT-100, WT-50

HARD DIRT, FROZEN SOIL	
Pilot Bit	50-TCH-171
Pilot Bit Adapter	PA 183L
Gage Tooth	1656 (bucket qty. 25)
Carbide Tooth	1658 (bucket qty. 25)
Tooth Holder	1XS, BT-100, WT-50

HARD DIRT, FROZEN SOIL	
Pilot Bit	P-1656
Gage Tooth	1656 (bucket qty. 25)
Carbide Tooth	1658 (bucket qty. 25)
Tooth Holder	1XS, BT-100, WT-50

ROCK DRILLING APPLICATIONS

The following options are available for drilling in hard, fracturable rock.

FRACTURABLE ROCK	
Pilot Bit	RCP-6.5
Bullet Tooth	SL-02 (bucket qty. 60)
Tooth Holder	P-87 (bucket qty. 25)

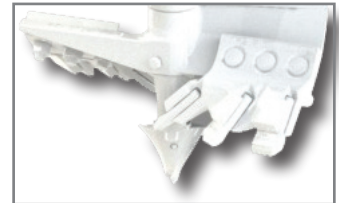

MDOBH BORING HEAD
Includes: Shank, Pilot Bit, Teeth and Holders

PITCH

DIA.	PITCH	TEETH per AUGER	"T" DIA.
8"	7"	2	9 1/2"
9"	7"	2	10 1/2"
10"	7"	2	11 3/4"
12"	7"	4	13 1/4"
14"	9"	4	15 3/4"
16"	9"	4	18"
18"	9"	6	20"
20"	12"	6	22"
22"	12"	6	23 1/2"
24"	12"	7	26"

The following pitches are typical for all PENGO MD Augers.

DIA.	PITCH	TEETH per AUGER	"T" DIA.
27"	18"	8	28 1/2"
30"	18"	8	31 1/4"
36"	18"	8	37 3/4"
42"	18"	10	43 1/2"
48"	18"	13	49 1/2"

DIRT DRILLING APPLICATIONS

UTILITY AUGERS - DIRT with TriFlow® 600 Pilot, 1650 & 1652 Fas-N-Lok® Teeth

ITEM DESCRIPTION	DIA	2 1/2" HEX		2 5/8" HEX	
		ALTEC PN	PENGO PN	ALTEC PN	PENGO PN
8-MD-10460	8"	700-90049	100057	9000-11575	100058
9-MD-10460	9"	700-90050	100115	700-90079	100116
10-MD-10460	10"	700-90051	100173	700-90080	100174
12-MD-10460	12"	700-90052	100231	700-90081	100232
14-MD-10460	14"	700-90053	100289	700-90082	100290
16-MD-10460	16"	700-90054	100371	700-90083	100372
18-MD-10460	18"	700-90055	552408	700-90084	100454
20-MD-10460	20"	700-90056	101853	700-90085	100536
22-MD-10460	22"	700-90057	100593	700-90086	100594
24-MD-10460	24"	700-90058	101856	700-90087	100676
27-MD-10460	27"	700-90225	100733	9000-11576	100734
30-MD-10460	30"	700-90094	100791	9000-11578	100792
36-MD-10460	36"	700-90118	101857	9000-11579	100850

HARD DIRT, FROZEN SOIL DRILLING

UTILITY AUGERS - DIRT with FH-205C Pilot, 1656 & 1658 Fas-N-Lok® Teeth

ITEM DESCRIPTION	DIA	2 1/2" HEX		2 5/8" HEX	
		ALTEC PN	PENGO PN	ALTEC PN	PENGO PN
8-MD-10460	8"	700-90182	100045	9000-54560	100053
9-MD-10460	9"	700-90183	100103	700-90198	100111
10-MD-10460	10"	700-90184	100161	700-90194	100170
12-MD-10460	12"	700-90185	100219	9000-54563	100227
14-MD-10460	14"	700-90186	100277	9000-54564	100285
16-MD-10460	16"	700-90187	100351	700-90195	100364
18-MD-10460	18"	700-90188	100433	9000-54566	100445
20-MD-10460	20"	700-90189	100515	700-90196	100527
22-MD-10460	22"	700-90190	100581	700-90205	100589
24-MD-10460	24"	700-90191	100655	700-90197	100667
30-MD-10460	30"	700-90192	100779	9000-54570	100787
36-MD-10460	36"	700-90193	100837	9000-54571	100845

UTILITY AUGERS - DIRT with P-1656 Pilot, 1656 & 1658 Fas-N-Lok® Teeth

ITEM DESCRIPTION	DIA	2 1/2" HEX		2 5/8" HEX	
		ALTEC PN	PENGO PN	ALTEC PN	PENGO PN
8-MD-10460	8"	9000-54600	100047	9000-54620	100055
9-MD-10460	9"	9000-54601	100105	9000-54621	100113
10-MD-10460	10"	9000-54602	100163	9705-86546	100172
16-MD-10460	16"	9000-54605	100353	9705-86556	100366
18-MD-10460	18"	9000-54606	100435	9000-54626	100447
20-MD-10460	20"	9000-54607	100517	-	-
22-MD-10460	22"	9000-54608	100583	9000-54628	100591
24-MD-10460	24"	9000-54609	100657	9000-54609	100657
30-MD-10460	30"	9000-54610	100781	9000-54630	100789
36-MD-10460	36"	9000-54611	100839	9000-54631	100847



DIRT DRILLING APPLICATIONS



ROCK DRILLING APPLICATIONS

UTILITY AUGERS - ROCK with RCP-6.5 Pilot,

ITEM	DIA	2 1/2" HEX ALTEC PN	2 1/2" HEX PENGO PN
16-MD-10460	16"	9000-54480	100357
18-MD-10460	18"	9000-54436	100439
20-MD-10460	20"	9700-16405	100521
24-MD-10460	24"	9000-55483	100661

ITEM	DIA	2 5/8" HEX ALTEC PN	2 5/8" HEX PENGO PN
16-MD-10460	16"	9000-54450	100369
18-MD-10460	18"	9000-54451	100451
20-MD-10460	20"	9000-54497	100533

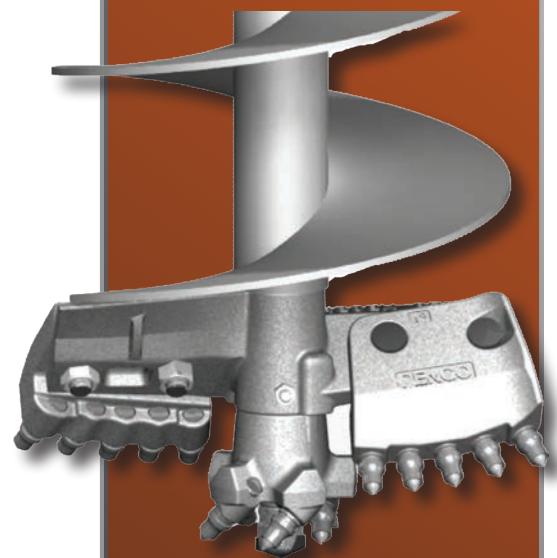

AUGER EQUIPMENT

USA: 1-877-GO ALTEC
(1-877-462-5832)

www.alteconnect.com



MDOBH HEADS

Use the PENGO MDOBH Heads to fix or repair PENGO MD augers. The heads are shipped with either a FH-205 Pilot, FH-205C carbide tipped pilot or a P-1650 Dirt Pilot. See picture below for parts included with each head.

REORDER PARTS



700-90061
FH-205

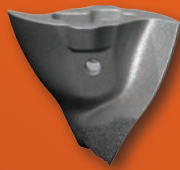

700-90176
FH-205C



700-90123
P-1650



8994-08300
P-1656



700-90062
1650 Dirt



700-90095
1652 Gage



700-90063
1656 Carbide



700-90091
1658 Carbide



9000-51273
1851 Dirt



24" MDOBH with FH-205 Pilot
Included:

- Pilot Bit
- Pilot Bit Adapter
- Shank Plates
- Fas-N-Lok Dirt Teeth
- Nuts and Bolts

FH-205 PILOTS

ITEM DESCRIPTION	DIA	NO. TEETH	ALTEC PART NO.	PENGO PART NO.
8-MDOBH FH-205	8"	2 [1652]	7163-02043	552005
9-MDOBH FH-205	9"	2 [1652]	7163-02044	552010
16-MDOBH FH-205	16"	2 [1851]	7163-02123	552035
18-MDOBH FH-205	18"	4 [1851]	7163-02051	552040
20-MDOBH FH-205	20"	1 [1650] 4 [1851]	7163-02120	552045
22-MDOBH FH-205	22"	1 [1650] 4 [1851]	7163-02054	552050
24-MDOBH FH-205	24"	1 [1650] 5 [1851]	7163-02119	552055

FH-205C PILOTS

ITEM DESCRIPTION	DIA	NO. TEETH	ALTEC PART NO.	PENGO PART NO.
12-MDOBH FH-205C CARBIDE	12"	2 [1658] 2 [1656]	9702-53205	554764
24-MDOBH FH-205C CARBIDE	24"	2 [1658] 5 [1656]	9000-99681	552057

P-1650 PILOTS

ITEM DESCRIPTION	DIA	NO. TEETH	ALTEC PART NO.	PENGO PART NO.
18-MDOBH P-1650	18"	6 [1851]	9703-13253	554807
22-MDOBH P-1650	22"	2 [1851] 4 [1652]	7163-02173	554809

P-1656 PILOTS

ITEM DESCRIPTION	DIA	NO. TEETH	ALTEC PART NO.	PENGO PART NO.
18-MDOBH P-1656	18"	2 [1656] 4 [1658]	9705-57896	554787
22-MDOBH P-1656	22"	2 [1656] 4 [1658]	9705-57897	554789

AUGER EQUIPMENT

USA: 1-877-GO ALTEC
(1-877-462-5832)

www.alteconnect.com



STEP ROCK AUGERS

The following components are included in the complete auger system. The step rock auger is best suited for non-fracturable rock. It includes pilot bit and drag style teeth. Parts are available for replacing worn parts or repairing the auger itself.

Overall Length	104"
Flight Length	60"
Diameters	9" thru 36"
Flight Thickness	5/16"
Dish	9" Cast/Std Lug
Hex Hub Connection	2 1/2" or 2 5/8"
Pilot Bit	P-6000
Teeth	PFC-5 (bucket qty. 50)
Holder	PFC-5H

ITEM DESCRIPTION	DIA	2 1/2" HEX		2 5/8" HEX	
		ALTEC PN	PENGO PN	ALTEC PN	PENGO PN
9MDR10460	9"	9000-54330	554330	9000-09258	101101
10MDR10460	10"	9000-54331	554331	9000-10258	101103
12MDR10460	12"	9000-54332	554332	9000-12258	101105
14MDR10460	14"	9705-57898	554333	9702-06888	101107
16MDR10460	16"	9705-57899	554320	9000-16258	101109
18MDR10460	18"	9000-54335	554335	9000-18258	101111
20MDR10460	20"	9000-54321	554321	9000-15258	101113
24MDR10460	24"	9705-57900	554322	9000-24258	101115
30MDR10460	30"	9000-54338	554338	9000-30258	101117
36MDR10460	36"	9705-57901	554339	9000-36258	101119

REORDER PARTS



P-6000
9000-51273
151275



PFC-5
0700-09008
140115



PFC-5H
9000-40119
157027



HEX HUB CONNECTION

OVERALL LENGTH
104"

DISH

FLIGHT THICKNESS

SINGLE FLIGHT LENGTH
60"

P-6000 PILOT

TEETH
PFC-5
HOLDERS
PFC-5H

AUGER EQUIPMENT

USA: 1-877-GO ALTEC
(1-877-462-5832)

www.alteconnect.com

Images Are Not To Scale.



AUGER EQUIPMENT

USA: 1-877-GO ALTEC
(1-877-462-5832)

www.alteconnect.com



ROCK RIPPER® ROCK AUGERS

The Rock Ripper® augers for utility features a progressive-style design which maximizes drilling for all types of digger derricks. The Rock Ripper® augers are for solid, non-fracturable rock and compacted soil. The Rock Ripper® features the STRATA® Series SR-76W conical teeth.

Overall Length	104"
Flight Length	60"
Diameters	9" thru 36"
Flight Thickness	5/16"
Dish	9" Cast/Std Lug
Hex Hub Connection	2 1/2" or 2 5/8"
Pilot Bit	RRP 1.75 SQ
Teeth	SR-76SW (bucket qty. 50)
Holder	P-10 (bucket qty. 35)



ITEM DESCRIPTION	DIA	2 1/2" HEX		2 5/8" HEX	
		ALTEC PN	PENGO PN	ALTEC PN	PENGO PN
9-MRR-10460	9"	9000-33600	101842	9000-25809	101151
10-MRR-10460	10"	9702-58602	134705	9704-86652	102170
12-MRR-10460	12"	9000-33601	133601	9000-25812	101153
14-MRR-10460	14"	9705-86234	102865	-	-
16-MRR-10460	16"	9000-33602	133602	9000-25816	101155
18-MRR-10460	18"	9000-33603	101844	9000-25818	101157
20-MRR-10460	20"	9000-33604	133604	9000-25820	101159
22-MRR-10460	22"	9700-40565	101679	9704-03377	102898
24-MRR-10460	24"	8130-00720	101846	7017-05033	101161
30-MRR-10460	30"	9000-33606	101851	9000-25830	101163
36-MRR-10460	36"	9700-40568	133615	9000-40569	101165

REORDER PARTS

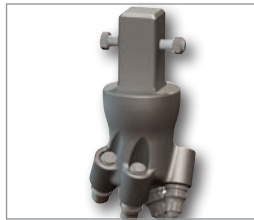

RR-1.75 SQ
9700-50099
137208



SR-76SW
9703-65049
850035



P-10
9000-34039
990043

NOTE: The SR-76SW is the Strata Series Conical Tooth. Altec P/N 9703-45698 (S-RL08), may also be used.

The newly designed Rock Ripper® is designed to cut through the rock leaving smaller dust particles (top right), not grind the rock, which leaves bigger chunks (bottom right). The benefit of the Rock Ripper® "biting" into the rock is that it reduces vibration and increases drilling production at the same time.



MD QUICK CHANGE AUGERS

The MD Quick Change is a versatile auger that consists of one flight and three interchangeable heads. This auger system will allow the user to drill in any conditions.

Overall Length	104" (with head)
Flight Length	60"
Diameters	9" thru 36"
Flight Thickness	5/16"
Dish	9" Cast/Std Lug

Hex Hub Connection	2 1/2" or 2 5/8"
Pilot Bit	See Options
Teeth	See Options
Holder	See Options

FLIGHT BODIES

ITEM DESCRIPTION	DIA	2 1/2" HEX		2 5/8" HEX	
		ALTEC PN	PENGO PN	ALTEC PN	PENGO PN
8-FMD-10460	8"	9000-56575	556575	9000-56576	101017
9-FMD-10460	9"	9000-56580	556580	9000-56581	101019
10-FMD-10460	10"	9000-56585	556585	9000-56586	101021
12-FMD-10460	12"	9000-56595	556595	9000-56596	101023
14-FMD-10460	14"	9000-56600	556600	9000-56601	101025
16-FMD-10460	16"	9000-56605	556605	9000-56606	101027
18-FMD-10460	18"	9000-56610	556610	9000-56611	101029
20-FMD-10460	20"	9000-56615	556615	9000-56616	101031
22-FMD-10460	22"	9000-56620	556620	9000-56621	101033
24-FMD-10460	24"	9000-56625	556625	9000-56626	101035
26-FMD-10460	26"	9000-56630	556630	9000-56631	101037
27-FMD-10460	27"	9000-56635	556635	9000-56636	101039
30-FMD-10460	30"	9000-56640	556640	9000-56641	101041
36-FMD-10460	36"	9000-56645	556645	9000-56646	101043

*NOTE: The above flight bodies are compatible only with the pin on heads with a 2 1/4" Hex Stem listed on next page.



OVERALL LENGTH
104"
(once head is added)

HEX HUB CONNECTION

DISH

FLIGHT THICKNESS

SINGLE FLIGHT LENGTH
60"

AUGER EQUIPMENT

USA: 1-877-GO ALTEC
(1-877-462-5832)

www.alteconnect.com



Images Are Not To Scale.



**OPTION 1 -
DIRT HEAD**
FH-205 Pilot,
1652 and 1650
Fas-N-Lok®Teeth



**OPTION 2 -
STEP ROCK HEAD**
P-6000 Pilot, PFC-5 Teeth



AUGER EQUIPMENT

USA: 1-877-GO ALTEC
(1-877-462-5832)

www.alteconnect.com

ITEM	DIA.	ALTEC PN	PENGO PN
POMDH-8	8"	9000-56500	556500
POMDH-9	9"	9000-56505	556505
POMDH-10	10"	9000-56510	556510
POMDH-12	12"	9000-56520	556520
POMDH-14	14"	9000-56525	556525
POMDH-16	16"	9000-56530	556530
POMDH-18	18"	9000-56535	556535
POMDH-20	20"	9700-29773	556540
POMDH-22	22"	9000-56545	556545
POMDH-24	24"	9000-56550	556550
POMDH-26	26"	9000-56555	556555
POMDH-27	27"	9000-56560	556560
POMDH-30	30"	9000-56565	556565
POMDH-36	36"	9000-56570	556570

ITEM	DIA	ALTEC PN	PENGO PN
POMDR-9	9"	9000-54680	554680
POMDR-10	10"	9000-54687	554687
POMDR-12	12"	9000-54681	554681
POMDR-14	14"	9704-74864	554688
POMDR-16	16"	9705-57902	554682
POMDR-18	18"	9702-84729	554683
POMDR-20	20"	9000-54684	554684
POMDR-24	24"	9000-54685	554685
POMDR-30	30"	9705-57903	554686
POMDR-36	36"	9705-57904	554689

OPTION 1 - DIRT HEAD
TF-600 Pilot,
1652 and 1650 Fas-N-Lok® Teeth

ITEM	DIA.	ALTEC PN	PENGO PN
POMDH-8	8"	9705-57905	101579
POMDH-9	9"	9705-57906	101867
POMDH-10	10"	9703-34379	101581
POMDH-12	12"	9703-35424	101582
POMDH-14	14"	9705-57907	101583
POMDH-16	16"	9705-57908	101584
POMDH-18	18"	9000-91605	101585
POMDH-20	20"	9000-56540	101869
POMDH-22	22"	9705-57909	101587
POMDH-24	24"	9705-57910	101588
POMDH-26	26"	9705-57911	101589
POMDH-27	27"	9705-57912	101590
POMDH-30	30"	9705-57913	101591
POMDH-36	36"	9705-57914	101592

**OPTION 3 -
ROCK RIPPER HEAD**
RR-1.75 SQ Pilot,
Strata® SR-76SW Bullet Teeth



ITEM	DIA	ALTEC PN	PENGO PN
POMRR-8	8"	9000-56150	133690
POMRR-9	9"	9000-33607	133607
POMRR-10	10"	9000-56160	133621
POMRR-12	12"	9000-56170	133608
POMRR-14	14"	9000-56175	102095
POMRR-16	16"	9000-56180	133609
POMRR-18	18"	9000-56185	133610
POMRR-20	20"	9700-18791	133611
POMRR-24	24"	9000-56200	133612
POMRR-30	30"	9000-56215	133613
POMRR-36	36"	9702-28911	133620

SEVERE ROCK RIPPER® AUGERS

The Severe Rock Ripper® auger is for solid, non-fracturable rock and compacted soil. It comes with the SRL-08 bullet tooth, you may reorder the STRATA® Series SR-76W conical teeth for optimal drilling. For use with the ALTEC Backyard Digger Derrick.

Overall Length	58"
Diameters	9" thru 36"
Flight Thickness	1/2"
Center Shaft	3.5" OD x .3" W
Hex Hub Connection	2"
Pilot Bit	RRP 1.75 SQ
Teeth	SL-08 (bucket qty. 60)
Holder	P-10 (bucket qty. 25)

ITEM DESCRIPTION	DIA	2" HEX ALTEC PN	2" HEX PENGO PN
6-SRR-58	6"	9703-58729	102842
9-SRR-58	9"	9703-59275	102843
12-SRR-58	12"	9703-59281	102844
16-SRR-58	16"	9703-55069	102845
18-SRR-58	18"	9702-64423	102634

REORDER PARTS



RR-1.75 SQ
9700-50099
137208



SL-08
700-90121
850032



P-10
9000-34039
990043



SR-76SW
9703-65049
850035

STRATA
DRILLING GRADE CARBIDE

The Improved Grade of Carbide in All Strata Teeth Increases The Life Cycle of The Tooth



HEX HUB CONNECTION

OVERALL LENGTH 48"

FLIGHT THICKNESS

RRP 1.75 SQ PILOT

TEETH SRL-08 HOLDERS P-10



AUGER EQUIPMENT

USA: 1-877-GO ALTEC
(1-877-462-5832)

www.alteconnect.com

Images Are Not To Scale.



AUGER EQUIPMENT

**USA: 1-877-GO ALTEC
(1-877-462-5832)**

www.alteconnect.com

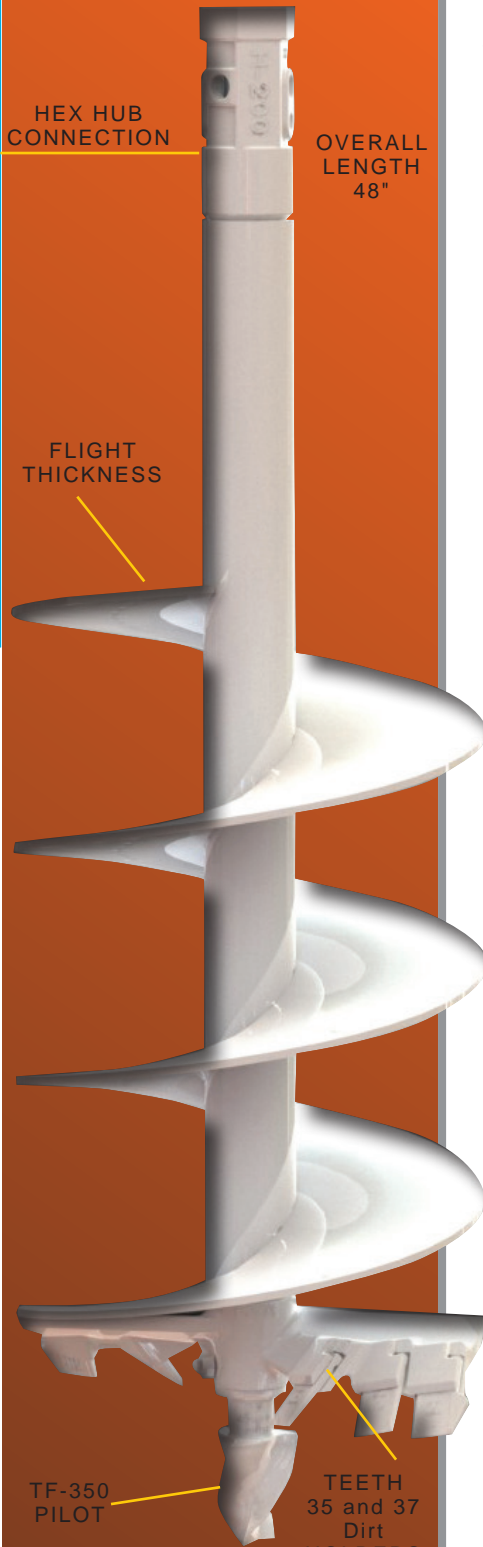

TRIMAX[®] AUGERS for BACKYARD DERRICKS

The TriMax[®] auger is specially designed for the ALTEC Backyard Derricks. The overall length of the auger is 58" and features the TriFlow[®] 350 pilot and 35 Series Fas-N-Lok[®] teeth. A carbide pilot is available for tougher ground conditions.

Overall Length	49"-60"
Diameters	9" thru 36"
Flight Thickness	1/2"
Center Shaft	3.5" OD x .3" W
Hex Hub Connection	2"
Pilot Bit	TF-350
Teeth	35 and 37 Dirt
Holder	T-35 or T-36



ITEM DESCRIPTION	DIA	2" HEX	
		ALTEC PN	PENGO PN
16-TM-58	16"	9703-10802	134943
18-TM-49	18"	9700-20535	134940
18-TM-59	18"	9701-73878	134941
20-TM-60	20"	9702-91544	553118

CARBIDE TRIMAX AUGER

ITEM DESCRIPTION	DIA	2" HEX	
		ALTEC PN	PENGO PN
18-TM-59	18"	9702-26183	134942

DOUBLE FLIGHT TRIMAX AUGERS

ITEM DESCRIPTION	DIA	2" HEX	
		ALTEC PN	PENGO PN
16-TM-59D	16"	9704-94300	103072
18-TM-59D	18"	9704-94285	103070
20-TM-59D	20"	9704-94301	103071

DOUBLE FLIGHT CARBIDE TRIMAX AUGERS

ITEM DESCRIPTION	DIA	2" HEX	
		ALTEC PN	PENGO PN
18-TM-59D	18"	9702-56911	102615

Additional Parts that may be used with the TriMax[®]



59" EXTENSION
9701-73948
134832



PRESSURE DIGGER AUGERS

PRESSURE DIGGER DIRT AUGERS - PDD

The Pengo PDD augers are built with a cast heat-treated head that provides superior wear and performance compared to normal fabricated augers. In addition the cast head is field repairable with standard welding techniques, utilizing low hydrogen welding rods and no pre- or post-heating requirement.

The PDD augers feature a cast head with the patented TriFlow® Pilot bit and Pengo's Fas-N-Lok® dirt teeth. Replacement heads and parts are available for the PDDs.



Overall Length	30"
Diameters	18" thru 72"
Flight Thickness	1"
Square Hub	3 1/2"
Pilot Bit	TF-1000
Dirt Teeth	2070 & 2072
Holders	WA and FA 70

ITEM DESC.	DIA	NO. OF 2070 TEETH	NO. OF 2072 TEETH	3 1/2" SQUARE	
				ALTEC PN	PENGO PN
18-PDD-30	18"	2	1	9702-54148	136339
20-PDD-30	20"	2	2	9702-54149	136340
24-PDD-30	24"	3	2	9702-54150	136341
28-PDD-30	26"	4	2	9702-47689	102593
30-PDD-30	30"	6	2	9705-57915	136343
36-PDD-30	36"	8	2	9702-47690	136344
42-PDD-30	42"	10	2	9702-46777	102586

REORDER PARTS



TF-1000
9703-63905
137348



2070
9703-63920
140002



2072
9705-57927
850223



WA-70
9705-57920
158120



FA-70
9705-57919
158110



AUGER EQUIPMENT

USA: 1-877-GO ALTEC
(1-877-462-5832)

www.alteconnect.com

Images Are Not To Scale.



PRESSURE DIGGER AUGERS

PRESSURE DIGGER ROCK AUGERS - PDR

Pengo True Cut PDR augers are made with thick, heat-treated cast alloy heads and use heavy-duty 1" shank bullet-style teeth. The cast heat treated head provides superior wear and performance compared to normal fabricated augers.

The PDRs are shipped with the new STRATA® Conical Teeth which have a proprietary drilling grade carbide that increases the life of the tooth. Less down time means increased production and productivity. Remember to reorder STRATA® SR100 Conical Teeth to maintain optimum wear.

AUGER EQUIPMENT

USA: 1-877-GO ALTEC
(1-877-462-5832)

www.alteconnect.com

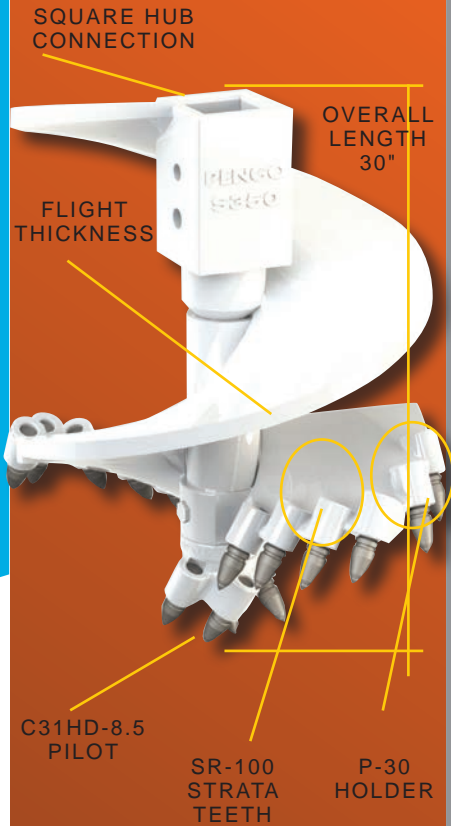

Overall Length	30"
Diameters	9" thru 72"
Flight Thickness	1"
Square Hub	3 1/2"
Pilot Bit	B40-8.5
Teeth	SR-100 (bucket qty. 35)
Holders	P-30 (bucket qty. 12)

ITEM DESCRIPTION	DIA	NO. OF TEETH	3 1/2" SQUARE	
			ALTEC PN	PENGO PN
9-PDR-30	9"	7	700-90314	137520
10-PDR-30	10"	4	9701-03788	137518
12-PDR-30	12"	8	9000-37521	137521
16-PDR-30	16"	8	700-90315	137522
18-PDR-30	18"	9	9000-37523	101847
20-PDR-30	20"	11	700-90316	137519
24-PDR-30	24"	12	9000-37524	137524
26-PDR-30	26"	14	9700-73569	137517
30-PDR-30	30"	17	9000-99915	101849
36-PDR-30	36"	20	9000-99953	101850
42-PDR-30	42"	24	9000-37527	137527
48-PDR-30	48"	28	9000-99934	137528
60-PDR-30	60"	37	9000-99935	137529
72-PDR-30	72"	48	9701-24923	137530

REORDER PARTS



C31HD-8.5
9701-11268
135913



SR-100
9000-34053
850037



P30
9000-34061
990001

BULLET STYLE SHANK & PILOT KITS



AUGER EQUIPMENT

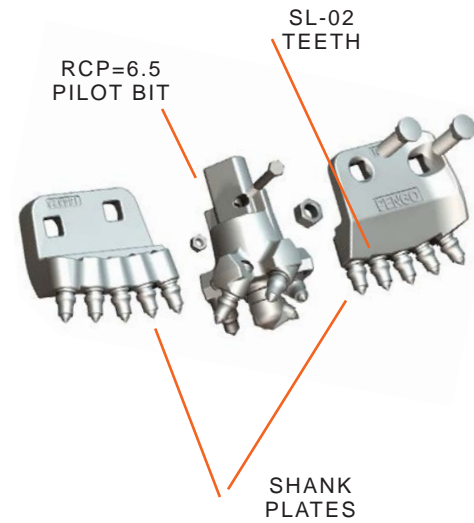

BULLET STYLE SHANK & PILOT KITS

Conical type bullet style shank plates for permafrost, concrete, and most fracturable rock. Kit contains: Shank Plates, 6.5" Center Pilot, and SL-02 bullet teeth.

DESCRIPTION	NO. TEETH	LBS	ALTEC PART NO.	PENGO PART NO.
16" Dia. Kit	13	43.5	700-09001	554230
18" Dia. Kit	15	48	700-09007	554231
20" Dia. Kit	15	51.5	700-09003	554232
24" Dia Kit	17	26.5	9000-54233	544233

BULLET STYLE SHANK SUB ASSEMBLIES

The sub assemblies listed below are for repair or replacement of worn shanks. They are shipped complete with shank plate, SL-02 bullet teeth and nuts and bolts.

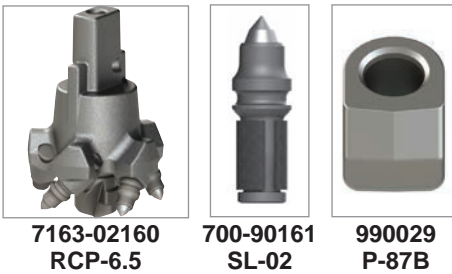

DESCRIPTION	NO. TEETH	LBS	ALTEC PART NO.	PENGO PART NO.
16" Shank Plate	4	12.5	9000-54240	554240
18" Shank Plate	5	15	9000-54241	554241
20" Shank Plate	5	16.5	9000-54242	554242
24" Shank Plate	6	19	8938-51410	554243

1650 DIRT SERIES BOLT ON SHANK PLATES

The following items below are to for repair or replacement of worn dirt shanks for MD augers. Each shank comes with 1650 dirt and 1652 dirt gage Fas-N-Lok® teeth and nuts/bolts.

ITEM	MM		NO. TEETH	NO. BOLTS	LBS.	ALTEC PART NO.	PENGO PART NO.
8"-10"	203	810X	1	1	5.5	700-90065	131854
11"-13"	279	12X	2	1	11.0	700-90066	131770
14"	356	145X	2	2	10.85	700-90067	131788
16"	406	16X1	2	2	9.5	700-90069	131790
16"		16X2	2	2	9.5	700-90068	131791
18"	457	18X1	3	2	14.0	700-90071	131732
18"		18X2	3	2	14.0	700-90070	131733
20"	508	20X-1	3	2	14.0	700-90073	131866
20"		20X-2	3	2	14.0	700-90072	131867
22"	559	22X-1	3	3	16.0	700-90075	131974
22"		22X-2	3	3	16.0	700-90074	131975
24"	610	24X-1	3	3	18.0	700-90077	131872
24"		24X-2	4	3	18.0	700-90076	131873
26"-27"	620	267X-1	4	4	20.5	7163-02087	131976
26"-27"		267X-2	4	4	20.5	7163-02088	131977
30	762	30X-1	4	4	25.5	7163-02126	131878
30		30X-2	4	4	25.5	7163-02127	131879
36	914	36X-1	4	4	32.0	7163-02128	131884
36		36X-2	4	4	32.0	7163-02129	131885



How To Determine Which Shank You Need:

Example - 20X-1 and 20X-2.

Order one of each if your need to replace both shanks.

If you only need to replace one shank, you must be able to retrieve the number from shank you are replacing or the existing shank. This number will help us determine the correct shank for you to order.

**USA: 1-877-GO ALTEC
(1-877-462-5832)**

www.alteconnect.com

Images Are Not To Scale.





HUBS, COUPLERS, EXTENSIONS & ADAPTERS

AUGER EQUIPMENT

USA: 1-877-GO ALTEC
(1-877-462-5832)

www.alteconnect.com

WELD ON HEX HUBS

ITEM	LBS	ALTEC PART NO.	PENGO PART NO.
2" Hex	10.5	700-00009	154121
2 1/2" Hex	19.6	700-09011	154141
2 5/8" Hex	17.7	700-90180	154151
3" Square	40	9000-54205	154020
3 1/2" Square	52.3	9700-06166	154030



H-200
700-00009
154121



H-250
700-09011
154141



S-300
9000-54205
154120

SHAFT ADAPTERS

ITEM	LBS	ALTEC PART NO.	PENGO PART NO.
2 1/2" H Female X 2" Hex Male	29	9000-32419	132419
2 1/2" Hex Female X 2 5/8" Hex Male	31	9000-32984	136466
2" Hex Female X 2 1/2" Hex Male	22	9000-32609	132609
2 5/8" Hex Female X 2 1/2" Hex Male	30	9000-99797	132702
3 1/2" Sq. Female X 3" Sq. Male	77	9000-34797	134797



2 1/2" Hex Female X 2" Hex Male

HEX HUB COUPLERS

ITEM	A	L	LBS	ALTEC PART NO.	PENGO PART NO.
2" x 2" Hex Coupler	3"	8"	13	9000-53400	553400
2 1/2" x 2 1/2" Hex Coupler	5"	8"	22	9000-53402	553402
2 5/8" x 2 5/8" Coupler	8"	8"	21	9000-53403	553403

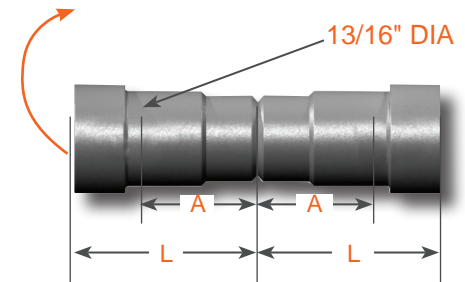

EXTENSION SHAFTS

ITEM	ALTEC PART NO.	PENGO PART NO.
2 5/8" Extension x 72"	700-00015	135784
2 1/2" Extension x 72"	700-00041	135787
2 5/8" Hex x 72"	700-00039	134816
2 1/2" Hex x 72"	700-00042	135782
2 5/8 x 72" Entergy	9702-70789	135762
2 1/2" F x 2 5/8" M	700-00058	135022
2 5/8" F x 2 1/2" M	700-00062	135890
2 5/8" Hex x 84"	9702-55772	134891
2 5/8" F x 2 1/2" M	9700-64034	135789
3" Hex x 72"	700-00043	134850
S350 x 48" Extension	9705-57916	137391

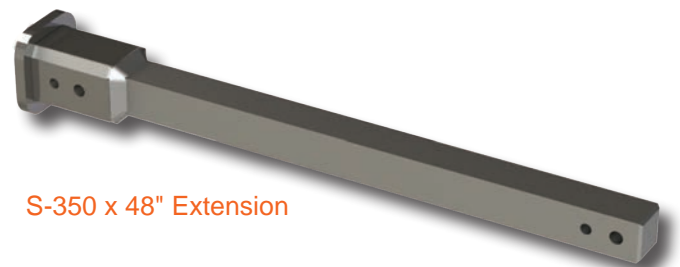

S-350 x 48" Extension

Images Are Not To Scale.



PILOT BITS & ADAPTERS

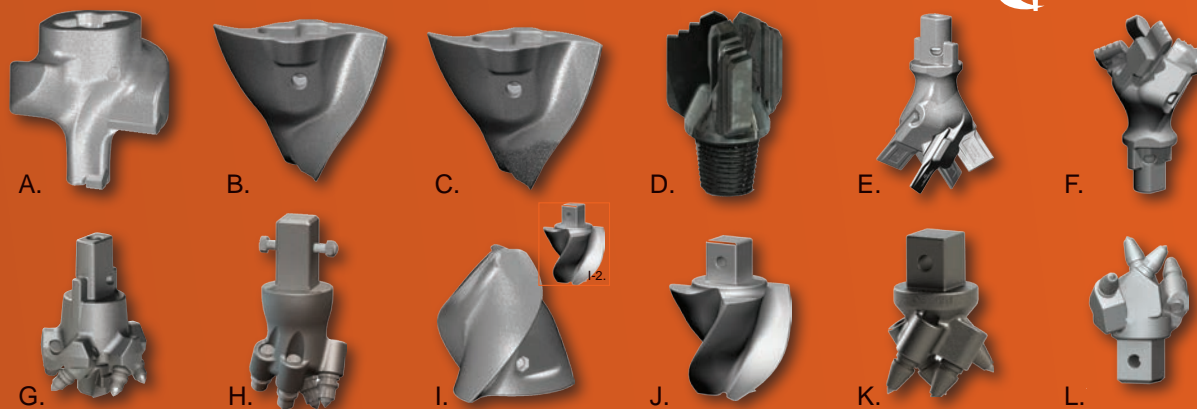

ITEM	DESCRIPTION	SOIL CONDITION	LBS	ALTEC PART NO.	PENGO PART NO.	
A.	50-TCH-171	5" Carbide Tipped	Concrete, Stone, Frozen	7	700-09002	199220
B.	FH-205	Dirt Pilot	Ordinary Dirt	3.5	700-90061	157382
C.	FH-205C	Carbide Tipped	Frozen, High Abrasive, Low Impact	3.7	700-90176	132260
D.	P-6000	4 3/4" Carbide	Solid, Non-fracturable Rock	8	9000-51273	151275
E.	P-1650	1851 and 1652 Teeth	Compacted, Fracturable Rock	20	700-90123	131726
F.	P-1656	1656 and 16580 Teeth	Frozen, High Abrasive, Low Impact	24	8994-08300	131727
G.	RCP-6.5	6 1/2" with Center Point	Fracturable Rock	18	7163-02160	132116
H.	RR-1.75 SQ	Rock Ripper® Square Stem		15	9700-50099	137208
I.	TF-600	TriFlow® Pilot Bit - no stem	Ordinary Dirt	10	9000-37350	137357
I-2.	TF-600	TriFlow® Pilot Bit - 1 3/4" Stem	Ordinary Dirt	12	9703-94460	137331
J.	TF-1000	TriFlow® Pilot Bit 2 1/2" Sq.	Ordinary Dirt	43	9703-63905	137348
K.	C31 Pilot	2 1/2" Sq. Pilot Pit	Fracturable Rock	30	9000-99000	135913
L.	B40-8.5 Pilot	2 1/2" Sq. for PDR Auger		30	9703-63902	135867

*Pilot Bit Assemblies include, pilot, nuts, bolts, and teeth (if applicable).

ITEM	DESCRIPTION	LBS	ALTEC PART NO.	PENGO PART NO.
141-L	Pilot Bit Adapter for TF-600	1.3	8935-07700	151970
PA-183-L	Pilot Bit Adapter	8	700-90093	151110
PA-182-L	Pilot Bit Adapter	4.3	7163-02107	151100
6" OD X 2 1/2" SQ	Adapter	17.8	9701-17232	151598

ITEM	DESCRIPTION	LBS	ALTEC PART NO.	PENGO PART NO.
3/8" x 3" Nut/Bolt	for use with 50-TCH-171	.4	9705-57917 9000-11582	131685 151672
1/2" x 4 1/2" Nut/Bolt	for use with P-1650	.4	9702-57671 7163-02105	131683 151680



141-L
8935-07700
151970

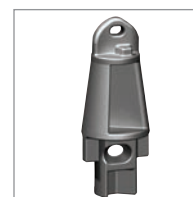

PA-183L
700-90093
151110



PA-182L
7163-02107
151100

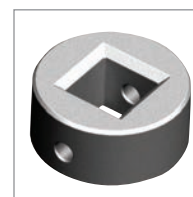

6" OD
9701-17232
151598



AUGER EQUIPMENT

USA: 1-877-GO ALTEC
(1-877-462-5832)

www.alteconnect.com

Images Are Not To Scale.



DIRT TEETH

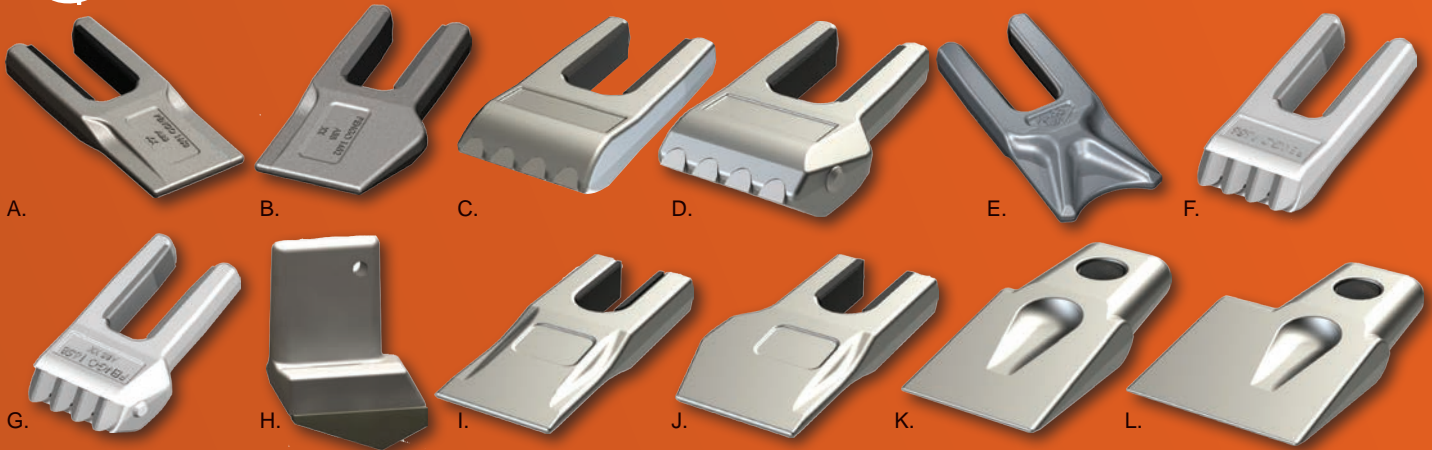

	ITEM	DESCRIPTION	DIGGING CONDITIONS	BUCKET QTY	LBS	ALTEC PART NO.	PENGO PART NO.
A.	1650	Fas-N-Lok® Dirt Tooth	Ordinary Dirt	50	1	700-90062	140200
B.	1652	Fas-N-Lok® Dirt Gage	Ordinary Dirt	50	1	700-90095	140020
C.	1656	Fas-N-Lok® Carbide Rock	High Abrasive Soil, Frozen Ground	25	1.25	700-90063	140005
D.	1658 Gage	Fas-N-Lok® Carbide Gage	Frozen, High Abrasive, Low Impact	25	1.36	700-90091	140006
E.	1851	Fas-N-Lok® Dirt	Ordinary Dirt	50	1	700-90096	140017
F.	RB-56	Fas-N-Lok® Ridge Breaker Dirt	Frozen, High Abrasive, Low Impact	25	1.4	700-90228	140022
G.	RB-58	Fas-N-Lok® RB Carbide Gage	Frozen, High Abrasive, Low Impact	25	1.2	700-90229	140015
H.	PFC-5	Carbide Rock	Solid, Non-Fracturable Rock	50	2.66	700-09008	140115
I.	2070	Fas-N-Lok® Dirt Tooth	Ordinary Dirt	20	2.2	9703-63920	140002
J.	2072 Gage	Fas-N-Lok® Dirt Gage Tooth	Ordinary Dirt	20	2.27	9704-05422	140000
K.	201	Dirt Tooth	Sand, Soil, Clay or Soft Rock	20	2.1	9701-17684	170030
L.	211	Dirt Tooth	Sand, Soil, Clay or Soft Rock	20	2.9	7163-02091	170034

DIRT TEETH HOLDERS

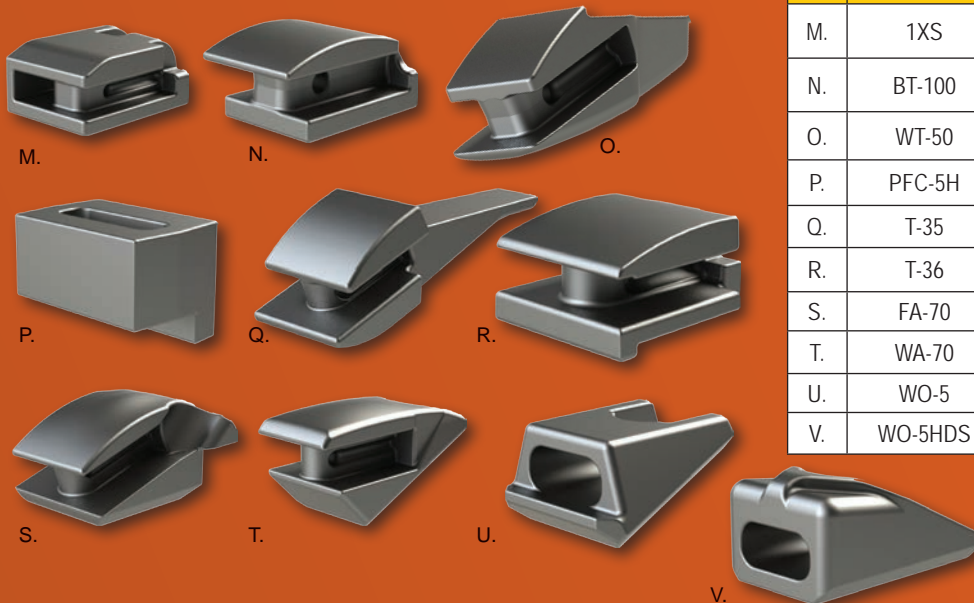

	ITEM	LBS	ALTEC PART NO.	PENGO PART NO.
M.	1XS	1.6	7163-02090	157010
N.	BT-100	1.6	9703-69730	157300
O.	WT-50	2.5	9705-57918	158115
P.	PFC-5H	1.2	9000-40119	157027
Q.	T-35	1	7163-02092	171221
R.	T-36	.5	9702-85762	171231
S.	FA-70	2	9705-57919	158110
T.	WA-70	2	9705-57920	158120
U.	WO-5	3.6	9000-71575	171575
V.	WO-5HDS	3.75	9703-57032	171574

AUGER EQUIPMENT

USA: 1-877-GO ALTEC
(1-877-462-5832)

www.alteconnect.com



ROCK TEETH

The following are bullet teeth used for digging in rock.



AUGER EQUIPMENT

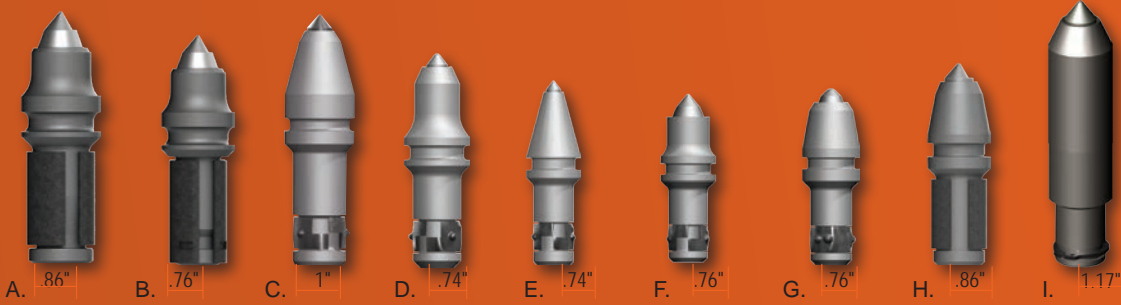

	ITEM	SHANK DIAMETER	BUCKET QTY.	HOLDER	LBS	ALTEC PART NO.	PENGO PART NO.
A.	SL-02	.86"	60	P87	.56	700-90161	850031
B.	SRL-08	.76	60	P10	.65	700-90121	850032
C.	S31HD	1"	35	P30	1.1	9000-34053	850037
D.	S21	.74"	65	P20	.3	9704-93072	850025
E.	S24	.74"	75	P20	.4	9000-00533	850029
F.	SRL-09	.76"	65	P10	.5	7163-20005	850017
G.	SRL-10	.76"	65	P10	.5	9704-41568	850022
H.	SL-04	.86"	65	S87HDS	.5	700-90162	850016
I.	S4-1	Step Shank [1.17"]	15	P4	2.6	9705-57921	850038

STRATA® CARBIDE DRILLING TEETH

The following bullet teeth are from our Strata® Series of carbide grade bullet teeth. These teeth are designed for drilling in rock.

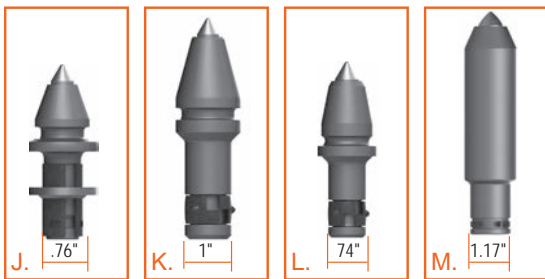

The STRATA® Proprietary Drilling Grade Teeth are Made Especially for the Drilling Industry!

Less Down Time Means Increased Production and Productivity!

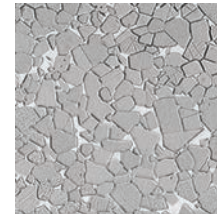

Strata Series Carbide Grain Structure

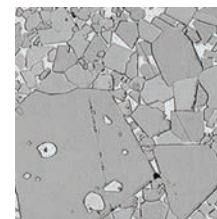

Conventional Carbide Grain Structure



All STRATA® conical tools are manufactured in the USA!

	ITEM	SHANK DIAMETER	BUCKET QTY.	HOLDER	LBS	ALTEC PART NO.	PENGO PART NO.
J.	SR-76SW	.76"	50	P10	.56	9703-65049	850035
K.	SR-100	1"	35	P30	1.1	9704-91722	850023
L.	SR-74	.74"	65	P20	.65	9702-46659	850027
M.	SR-104	Step Shank [1.17"]	15	P4	2.6	9703-63902	850024

USA: 1-877-GO ALTEC
(1-877-462-5832)

www.alteconnect.com

Images Are Not To Scale.



ROCK TEETH HOLDERS & TOOLS

The following are bullet teeth used for digging in rock. These teeth may be referred to as conical teeth, rock teeth or Strata teeth.

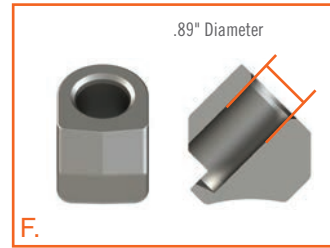
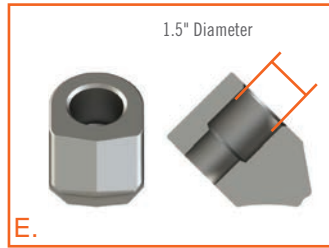
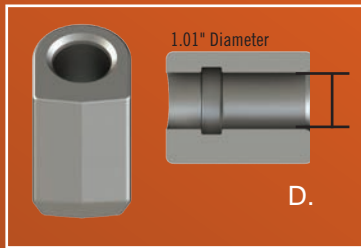
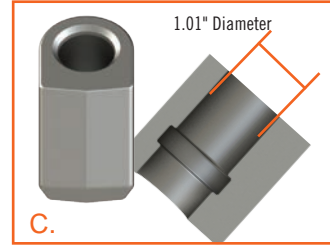
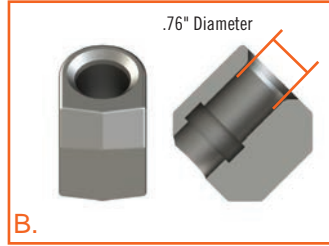
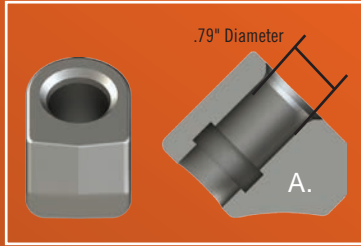

	ITEM	FITS SHANK DIA.	BUCKET QTY.	LBS	ALTEC PART NO.	PENGO PART NO.
A.	P-10	.76"	35	.5	9000-34039	990043
B.	P-20	.74"	40	.7	9000-10227	990002
C.	P-30	1"	12	2.6	9000-34061	990001
D.	P-30F	1"	40	.7	9705-57922	990082
E.	P-4	STEP SHANK	8	3.65	9000-99908	990003
F.	P87B	.86"	25	2.6	9705-27715	990029

AUGER EQUIPMENT

USA: 1-877-GO ALTEC
(1-877-462-5832)

www.alteconnect.com

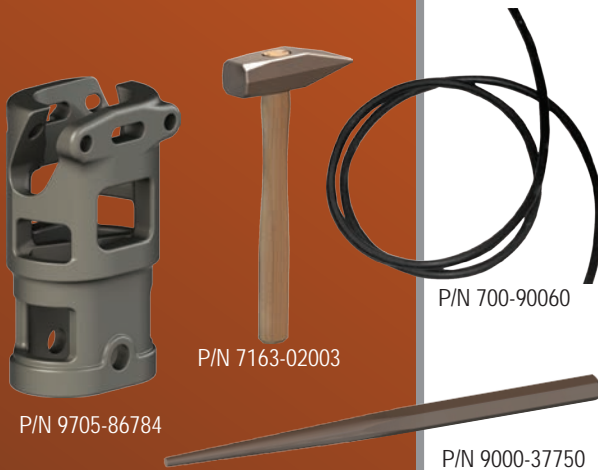

INSTALLATION TOOLS

ITEM	ALTEC PART NO.	PENGO PART NO.
Ribd-Rubr-Lok (4' lengths)	700-90060	137601
SH-85 Soft Hammer	7163-02003	137737
12250 Drift Punch	9000-37750	137750
SAT-85	9705-86784	157531

TOOTH REMOVAL TOOLS

ITEM	ALTEC PART NO.	PENGO PART NO.
S20HP Puller Bit (for .74 Shank)	9705-38979	850005
C123HP/U50HP (for .76 & .86 Shank)	9000-34091	134091
C30HP/U40HP Puller Bit	9704-71753	134090

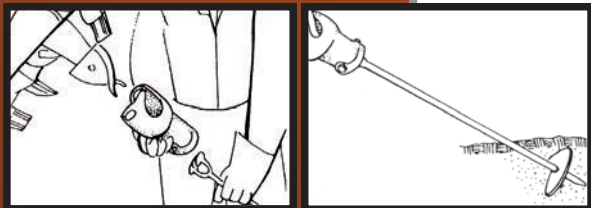

The SAT screw anchor tool is used for installing anchors, without having to remove the auger. Slip the tool over the pilot bit. (FH-205, C-120, SB-50) as shown.

Insert the thimble (eye) of the anchor into the end of the SAT-80. Screw anchor into the ground.

CAUTION: The SAT-80 is for use only on pressure diggers and only for installation, never for removal of anchors. Failure to meet these precautions may cause safety hazards.



Lewis Manufacturing Co.

AUGGER EQUIPMENT

Lewis Jobsite Debris Tarps

Maximum Work Load 1000 lbs.



Lewis' tarps are a convenient way of keeping the job site cleaner, saving time on back-fills. The tarps are made of **Heavy-Duty, Heat-Selaeed Rubberized Canvas**. Equipped with lifting handles. The tarp can be filled with dirt or other worksite debris. The handles, made of tough tubular nylon webbing, can be used to lift the tarp using a crane or other similar devices for **backfilling or taking the debris away**.

WARNING

DROP/CRUSH HAZARD, Never stand under a tarp when moving dirt or debris. DO NOT EXCEED the recommended Maximum Work Load



Lewis Rowdy's DirtBall™

Rowdy's DirtBall models come in two configurations in a variety of sizes and colors to suit your needs. The V-notch models allow you to get the tarp even closer to your work.



DirtBall in Action Installing a Utility Pole

Part No.	Lewis	Description	Size	WL lbs.	Canvas	Notch
9705-88839	90-2000	RDB-6x6-18	6' x 6'	1,000	18 oz.	-
9705-88840	90-2001	RDB-7x7-18	7' x 7'	1,000	18 oz.	-
9705-88841	90-2002	RDB-8x8-18	8' x 8'	1,000	18 oz.	-
9705-88842	90-2006	RDB-6x6-18V	6' x 6'	1,000	18 oz.	V
9705-88843	90-2007	RDB-7x7-18V	7' x 7'	1,000	18 oz.	V
9705-88844	90-2008	RDB-8x8-18V	8' x 8'	1,000	18 oz.	V
9705-88845	90-2003	RDB-6x6-22	6' x 6'	1,000	22 oz.	-
9705-88846	90-2004	RDB-7x7-22	7' x 7'	1,000	22 oz.	-
9705-88847	90-2005	RDB-8x8-22	8' x 8'	1,000	22 oz.	-
9705-88848	90-2009	RDB-6x6-22V	6' x 6'	1,000	22 oz.	V
9705-88849	90-2010	RDB-7x7-22V	7' x 7'	1,000	22 oz.	V
9705-88850	90-2011	RDB-8x8-22V	8' x 8'	1,000	22 oz.	V

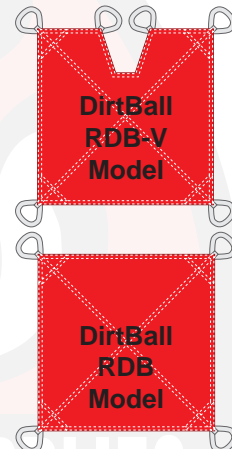

Lewis Rowdy's Auger Tarp



The Auger Tarp is similar to Rowdy's DirtBall but has a center opening. One side of the tarp has an overlapping slit that allows the tarp to be installed or removed from around a pole to keep the jobsite cleaner while digging. The overlapping slit on the side is secured using hook-loop closures and **Heavy-Duty Quick Release** buckles.

Part No.	Lewis	Description	Size	WL lbs.	Canvas	Hole Dia.
9705-88851	90-2015	RDB-A18-6x6-18	6' x 6'	1,000	18 oz.	18"
9705-88852	90-2016	RDB-A24-6x6-18	6' x 6'	1,000	18 oz.	24"
9705-88853	90-2017	RDB-A18-6x6-22	6' x 6'	1,000	22 oz.	18"
9705-88854	90-2018	RDB-A24-6x6-22	6' x 6'	1,000	22 oz.	24"
9705-88855	90-2019	RDB-A24-7x7-18	7' x 7'	1,000	18 oz.	24"
9705-88856	90-2020	RDB-A30-7x7-18	7' x 7'	1,000	18 oz.	30"
9705-88857	90-2021	RDB-A24-7x7-22	7' x 7'	1,000	22 oz.	24"
9705-88858	90-2022	RDB-A30-7x7-22	7' x 7'	1,000	22 oz.	30"
9705-88859	90-2023	RDB-A30-8x8-18	8' x 8'	1,000	18 oz.	30"
9705-88860	90-2024	RDB-A36-8x8-18	8' x 8'	1,000	18 oz.	36"
9705-88861	90-2025	RDB-A42-8x8-18	8' x 8'	1,000	18 oz.	42"
9705-88862	90-2026	RDB-A30-8x8-22	8' x 8'	1,000	22 oz.	30"
9705-88863	90-2027	RDB-A36-8x8-22	8' x 8'	1,000	22 oz.	36"
9705-88864	90-2028	RDB-A42-8x8-22	8' x 8'	1,000	22 oz.	42"

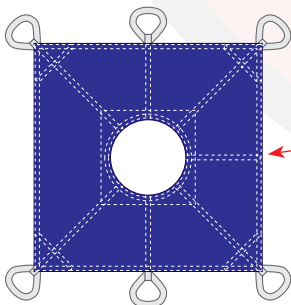

Overlapping Slit with Hook-Loop Fastener & Quick Release Buckles

USA: 1-877-GO ALTEC
(1-877-462-5832)

www.alteconnect.com

ALASKAUG AUGERS

by Auger Tech

**AUGER TECHNOLOGIES MANUFACTURES ALASKAUG AUGERS,
PILOT LINE CONTROLLERS, AUGER TOOLS, AND
PARTS TO THE ORIGINAL SPECIFICATIONS AND QUALITY.**

AUGER EQUIPMENT

**USA: 1-877-GO ALTEC
(1-877-462-5832)**

www.alteconnect.com

DUPLEX BOOM TYPE AUGERS

Rugged augers for use on digger derricks.

Featuring heavy extra thick flighting and DOM center tubes for years of reliable service.

Auger complete with kelly bar adapter, full set of teeth, and stowing dish.



Duplex

Diameter	Altec	2" Hex	Altec	2-1/2" Hex	Altec	2-5/8" Hex
8"	9706-37416	5608A	9706-37428	5608B	9706-37434	5608C
9"	9706-37417	5609A	9701-02234	5609B	9706-37435	5609C
10"	9706-37418	5610A	9706-37429	5610B	9706-37436	5610C
12"	9706-37419	5612A	9706-37430	5612B	9706-37437	5612C
14"	9706-37420	5614A	9706-37431	5614B	9706-37438	5614C
16"	9706-37421	5616A	7054-00199	5616B	9706-37439	5616C
18"	9706-37422	5618A	7054-00223	5618B	9706-37440	5618C
20"	9706-37423	5620A	9700-63246	5620B	9706-37441	5620C
22"	9706-37424	5622A	9700-72864	5622B	9706-37442	5622C
24"	9706-37425	5624A	9700-63249	5624B	9706-37443	5624C
30"	9706-37426	5630A	9706-37432	5630B	9706-37444	5630C
36"	9706-37427	5636A	9706-37433	5636B	9706-37445	5636C

STANDARD BOOM TYPE AUGERS

Rugged augers for use on digger derricks.

Featuring heavy extra thick flighting and DOM center tubes for years of reliable service.

Auger complete with kelly bar adapter, full set of teeth, and stowing dish.

Diameter	Altec	2" Hex	Altec	2-1/2" Hex	Altec	2-5/8" Hex
10"	9706-37446	5710A	9706-37456	5710B	9706-37464	5710C
12"	9706-37447	5712A	9706-37457	5712B	9706-37465	5712C
14"	9706-37448	5714A	9706-37458	5714B	9706-37466	5714C
16"	9706-37449	5716A	9706-37459	5716B	9706-37467	5716C
18"	9706-37450	5718A	970637460	5718B	9706-37468	5718C
20"	9706-37451	5720A	0700-90104	5720B	9706-37469	5720C
22"	9706-37452	5722A	9700-57483	5722B	9706-37470	5722C
24"	9706-37453	5724A	9706-37461	5724B	9706-37471	5724C
30"	9706-37454	5730A	9706-37462	5730B	9706-37472	5730C
36"	9706-37455	5736A	9706-37463	5736B	9706-37473	5736C

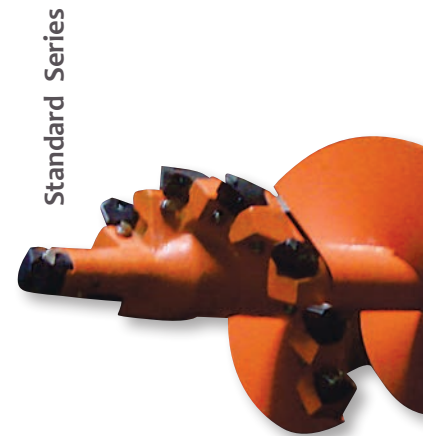

Standard Series



The Complete Alaskaug Rock Auger Line is Available.
Please call 1-877-GO ALTEC (1-877-462-5832).

9000 SERIES AUGERS

The 9000 series boom type auger was developed for the toughest drilling conditions. The auger features extra thick flighting, DOM center tubes, rugged cast steel hex drive, and the efficient Alaskaug 9000 cutter head.

Diameter	Altec	2" Hex	Altec	2-1/2" Hex	Altec	2-5/8" Hex
8"	9706-37474	9208A	9706-37474	9208B	9706-37488	9208C
10"	9706-37475	9210A	7054-00193	9210B	9706-37489	9210C
12"	9706-37476	9212A	7017-05078	9212B	9706-37490	9212C
14"	9706-37477	9214A	9706-37485	9214B	9706-37491	9214C
16"	9706-37478	9216A	700-90246	9216B	9706-37492	9216C
18"	7054-00575	9218A	7017-05071	9218B	9706-37493	9218C
20"	9706-37479	9220A	7017-05044	9220B	9700-28248	9220C
24"	9706-37480	9224A	7017-05072	9224B	9700-42033	9224C
30"	9706-37481	9230A	7017-05073	9230B	9706-37494	9230C
32"	9706-37482	9232A	9706-37486	9232B	9706-37495	9232C
36"	9706-37483	9236A	9706-37487	9236B	9706-37496	9236C

9000 Series



S-130 Anchor Auger

S-130 ANCHOR AUGER

- Bit creates a hole for many types of rock anchors
- A necessity on blast hole sites
- Durable and lightweight
- Manufactured from high strength resilient steel alloys
- Eliminates the need for compressors
- Will fit any size kelly bar
- Creates a hole depth of up to 31" deep (an extension is available that will increase depth by an additional 31" (S-131))
- Easily stored in tool box
- Equipped with Alaskaug's #1000 point for a 2 1/4" diameter hole
- The Blast Hole Bit features hex or square to fit any size kelly bar

S-130 Model - #1000 Point:

Alaskaug	Size	For Hex Kelly Bars	For Square Kelly Bars
S-130-A	2"	8940-02400	9703-54970
S-130-B	2-1/2"	9703-54965	9703-54975
S-130-C	2-5/8"	9703-54967	9703-54980

Please call 1-877-GO ALTEC (1-877-462-5832)
for more information regarding

ALASKAUG AUGERS
by Auger Tech

USA: 1-877-GO ALTEC
(1-877-462-5832)

www.alteconnect.com

AUGER ACCESSORIES

Auger Extension / Screw Anchor Drive Tool



- Hollow Kelly Bar with spring-loaded cam action locking dogs allows it to be used as both an auger extension shaft and a screw anchor drive
- This allows the screw anchor rod to be inserted directly into the Kelly Bar and eliminates the need for a screw anchor adapter
- Eliminates lifting and handling of heavy screw anchor adapters
- Allows quicker screw anchor setup time
- Spring loaded cam action dogs allow one-man insertion of anchor rod

P/N 700-00063 1.62 Dia Hole Thru (2.44 OD X 1.54 ID Sq Tube)



Auger Cover

- Acts as a dirt cover, preventing mud and dirt from falling into the truck bed as well as preventing rocks and dirt from hitting passing cars
- Made from heavy duty vinyl which allows for long-term use

P/N 9000-99718 Auger Bag

Wire/Nylon Wind-Up Slings

Part Number	Description
234-11001	8'6" Wire Rope
234-11024	9'6" Wire Rope
234-80004	10' Nylon Rope
234-80005	9' Nylon Rope

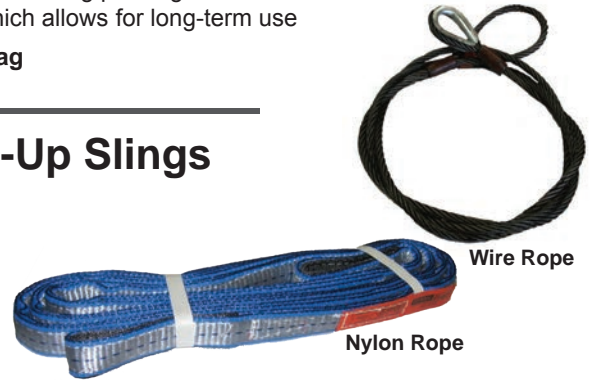

Wire Rope

Nylon Rope

AUGER DIRT SLINGS



- A flat "blanket", made of heavy duty 22 oz. vinyl and strengthened with heavy duty 2" webbing sewn around the edges
- Act as slings when attached to winches and make the transport of dirt, rock, and other materials simple, time-efficient, and cost-effective
- Provides usages as a blanket for tools and other items, keeping these items clean, localized, and ready to use, preventing loss of items in landscaping
- Ideal for the transport of necessary materials to a storage area or worksite
- Reduces injuries by eliminating the demanding forces associated with physical labor and repetitive movements
- Makes the job cleaner, easier, safer, and much more productive

Part Number	Size	Shape	Coverage		Rated Lift	Hold
			(Sq. Ft.)	(Cu. Ft.)		
9000-66666	7'	Triangle	36	14	700 lbs.	up to 35'
9000-66667	6'x 6'	Square	36	14	700 lbs.	up to 35'
9000-66668	7'x 7'	Square	49	22	1100 lbs.	up to 55'
9000-66669	8'x 8'	Square	64	34	1400 lbs.	all poles



Double Braided Polyester Rope



A strong and extremely durable construction ideally suited for controlled lifting and rigging operations where high strength, low elongation, and excellent abrasion resistance are required. It is manufactured using premium high tenacity fiber and conforms to the physical requirements of MIL-R-24677.

Double Braided Polyester has excellent abrasion resistance and strength retention in wet/dry environments, particularly under cyclical loading conditions. It also has excellent resistance to most common chemicals and UV exposure. The construction is torque-free and does not hockle or back turn, remaining flexible and easy to handle after extended use. This rope is easily spliced and can be readily fabricated into slings, winch lines and other types of standing and running rigging.

Features:

- High strength
- Low stretch
- Abrasion resistant
- Non-rotating
- Torque-free
- Minimum UV degradation
- Unlimited lengths
- Renders well on winches
- Excellent wet/dry strength retention
- Easily spliced
- Low stretch
- Can be urethane coated

Applications:

- Winch lines
- Stringing lines
- Underground pulling
- Slings
- Hoisting

Part Number	Diameter	Length	Overhead Working Load Limit (lbs.)	Eye#1	Eye#2
234-72002	1/2"	60'	1,640	4" Soft	Bronze Thimble
234-72005	1/2"	80'	1,640	3" Soft	Bronze Thimble
234-72007	7/16"	65'	1,520	4" Soft	Bronze Thimble
234-72019	7/16"	80'	1,320	4" Soft	Bronze Thimble
234-72021	1/2"	80'	1,640	4" Soft	Bronze Thimble
234-72022	7/16"	65'	1,320	4" Soft	Bronze Thimble
234-72032	1/2"	65'	1,640	3" Soft	Bronze Thimble
234-72035	1/2"	100'	1,640	4" Soft	4" Soft
234-75001	7/8"	70'	5,980	4" Soft	4" Soft
234-75002	7/8"	80'	5,980	4" Soft	4" Soft
234-76002	1"	100'	7,600	3" Soft	Bronze Thimble
234-76007	1"	60'	7,600	4" Soft	Bronze Thimble
234-76014	1"	60'	7,600	4" Soft	4" Soft
234-76015	1"	70'	7,600	4" Soft	4" Soft
234-76019	1"	100'	7,600	4" Soft	4" Soft
234-76021	1"	125'	7,600	3" Soft	3" Soft
234-76065	1"	125'	7,600	4" Soft	4" Soft
234-76069	1"	115'	7,600	4" Soft	4" Soft
234-76076	1"	60'	7,600	4" Soft	Bronze Thimble
234-76088	1"	85'	7,820	4" Soft	4" Soft
234-76069	1"	115'	7,820	4" Soft	4" Soft
234-77002	1 1/8"	100'	9,000	4" Soft	4" Soft
9000-91607	22 mm	110'	12,000	4" Soft	4" Soft

Altec offers a wide selection of ropes with various options. For information on additional rope options please contact your Altec representative toll free at 1-877-GO ALTEC to help determine which rope will best meet your needs.

ROPES

ROPES

USA: 1-877-GO ALTEC
(1-877-462-5832)

www.alteconnect.com

Double Braided Rope within Braided Polyester Jacket



A double braided rope within a braided polyester jacket. The extremely high strength and very low elongation core, coupled with the tough polyester cover, makes this rope a versatile product.

Features:

- Very low elongation
- Excellent strength to weight ratio
- Excellent wet/dry strength retention
- Torque-free non-hocking
- Stays flexible and easy to handle
- Splices well

Applications:

- Winch lines
- Stringing Lines
- Underground pulling lines
- Replacement for steel cable

Part Number	Diameter	Length	Overhead Working		Eye#2
			Load Limit (lbs.)	Eye#1	
234-72015	7/16"	105'	2,500	4" Soft	Bronze Thimble
234-72017	1/2"	75'	3,100	4" Soft	Bronze Thimble
234-75003	7/8"	80'	10,600	4" Soft	4" Soft
234-75004	7/8"	90'	10,600	4" Soft	4" Soft
234-75005	7/8"	115'	10,600	4" Soft	4" Soft
234-76081	1"	80'	13,000	4" Soft	4" Soft
234-76082	1"	90'	13,000	4" Soft	4" Soft
234-76083	1"	115'	13,000	4" Soft	4" Soft
234-76084	1"	120'	13,000	4" Soft	4" Soft
234-76085	1"	130'	13,000	4" Soft	4" Soft
234-77013	1 1/8"	115'	15,000	4" Soft	4" Soft
234-77014	1 1/8"	120'	15,000	4" Soft	4" Soft
234-77015	1 1/8"	130'	15,000	4" Soft	4" Soft
234-77016	1 1/8"	140'	15,000	4" Soft	4" Soft

Polyester Rope in a 12 Strand Braid



Nerex is a 100% polyester rope in a 12-strand single braid construction covered with urethane. Nerex is made up of a round construction which offers significantly higher strengths than double braids. Nerex's urethane coating provides superior snag and abrasion resistance in comparison to standard polyester 12-strand ropes.

Features:

- Very high strength
- Very low stretch
- Urethane coated
- Torque-free non-hocking
- Good strength to weight ratio
- Excellent abrasion and snag resistance
- Stays flexible and easy to handle
- Splices easily

Applications:

- Distribution & transmission stringing lines
- Pilot lines
- Underground pulling
- Fiber optic pulling line
- Winch lines
- Slings

WARNING: Synthetic rope may conduct electricity if inadvertent contact is made.

Part Number	Diameter	Length	Overhead Working		Eye#2
			Load Limit (lbs.)	Eye#1	
234-72012	1/2"	85'	2,360	3" Soft	2 Ton Swivel Hook & Thimble

Altec offers a wide selection of ropes with various options. For information on additional rope options please contact your Altec representative toll free at 1-877-GO ALTEC to help determine which rope will best meet your needs.

Twelve Strand Weave with a Polyester Jacket



This rope features twelve strand construction for a firm, round, and torque-free rope. It provides strength and elongation characteristics similar to steel wire rope at a fraction of the weight. Also, each rope is urethane-coated which creates a water barrier and improves abrasion and UV resistance.

Features:

- Excellent wet/dry strength retention
- Ultra low elongation
- Torque-free, non-rotating, non-hocking
- Round construction
- Easy to splice
- Excellent flexibility
- Unlimited lengths
- Floats

Applications:

- Winch lines
- Stringing lines
- Pilot lines
- Underground pulling
- Slings / hoisting ropes

Part Number	Diameter	Length	Overhead Working		
			Load Limit (lbs.)	Eye#1	Eye#2
234-75006	7/8"	90'	15,200	4" Soft	4" Soft
234-75007	7/8"	100'	15,200	4" Soft	4" Soft
234-76086	1"	130'	18,160	4" Soft	4" Soft
234-76087	1"	140'	18,160	4" Soft	4" Soft

Polyester Double Braid Rope



Stable Braid™ provides a firm 100% polyester double braid construction that yields high strength, low stretch, and excellent wear. The Duron™ fiber technology incorporates a Parallay™ plying, a braiding process which orients all the fibers parallel to the axis of the rope, and is the reason that Stable Braid™ maximizes performance.

Features:

- Low stretch
- Excellent abrasion resistance
- High strength-to-weight ratio
- Flexible and easy to handle
- Torque-free construction

Applications:

- Winch lines
- Stringing lines
- Underground pulling

Part Number	Diameter	Length	Overhead Working		
			Load Limit (lbs.)	Eye#1	Eye#2
234-72004	7/16"	75'	1,540	3" Soft	Bronze Thimble
234-72003	1/2"	75'	2,080	3" Soft	Bronze Thimble
234-72014	1/2"	80'	2,080	3" Soft	Bronze Thimble
234-72017	1/2"	75'	3,488	4" Soft w/Shackle	Bronze Thimble

Altec offers a wide selection of ropes with various options. For information on additional rope options please contact your Altec representative toll free at 1-877-GO ALTEC to help determine which rope will best meet your needs.

ROPE ACCESSORIES

ROPES

USA: 1-877-GO ALTEC
(1-877-462-5832)

www.alteconnect.com

Crosby Swivels

- All swivels individually proof tested/certified
- Equipped with tapered roller thrust bearing
- Suitable for frequent rotation under load
- All hooks furnished with latches assembled
- All jaws complete with bolts, nuts, and cotter pins
- Pressure lube fitting provided
- Not to be used on demolition (wrecking) balls



- Working Load Limit: 5 tons
Wire Rope Size: 5/8"
Weight: 15.51 lbs.
P/N 234-21010 Crosby 297217
- Working Load Limit: 8.5 tons
Wire Rope Size: 3/4"
Weight: 29.42 lbs.
P/N 234-21007 Crosby 297413
- Working Load Limit: 10 tons
Wire Rope Size: 7/8"
Weight: 42.5 lbs.
P/N 8130-00308 Crosby 297618

Other types and capacities up to 600 tons are available to meet your requirements. Please call 1-877-GO ALTEC (1-877-462-5832) for product availability / pricing.

Crosby Screw Pin Shackles



- Forged, quenched and tempered, with alloy pins
- Working load limit permanently shown on shackle
- Hot dip galvanized or self colored
- Fatigue rated
- Can meet DNV impact requirements of 42 joules at 20°C
- Meet or exceed all requirements of ASME B30.26 including identification, ductility, design factor,

- proof load, and temperature requirements
- Also meets other critical performance requirements including fatigue life, impact properties, and material traceability, not addressed by ASME B30.26
 - Screw pin anchor shackles meet the performance requirements of Federal Specification RR-C-271D Type IVA, Grade A, Class 2, except for those provisions required of the contractor

- P/N 9000-99580 1018446 7/16" 1 1/2 Ton Capacity, 1/2" Pin**
P/N 9007-10184 1018464 1/2" 2 Ton Capacity, 5/8" Pin
P/N 9000-99581 1018482 5/8" 3 1/4 Ton Capacity, 3/4" Pin
P/N 9000-99582 1018507 3/4" 4 3/4 Ton Capacity, 7/8" Pin
P/N 234-21005 1018523 7/8" 6 1/2 Ton Capacity, 1" Pin

Crosby Snatch Block



- 6" OL assembly for 1/2" wire line
- Forged alloy heat treated hooks
- Forged steel swivel tees, yokes and shackles
- Hook and shackle assemblies on 4 1/2" through 14" sizes can be interchanged
- Can be furnished with bronze bushings or roller bearings
- Opening feature permits insertion of rope while block is suspended from gin-pole
- 3" thru 18" 418 and 419 blocks have exclusive bolt retaining spring to assure no lost bolts
- Pressure lube fittings
- Fatigue rated
- 3" - 10" feature dual rated wireline sheaves

P/N 415-20154 Crosby 109037

Crosby L-160 Series Snatch Block



- Heavy Duty
- Hook is forged alloy steel - quenched and tempered
- Designed for fast, efficient line changes
- All parts are forged
- Beaded side plate prevents rope from jamming
- Blocks furnished with dual rated wireline sheaves
- Fatigue Rated
- Shackle Fitting
- Sheave Diameter: 5"
- Working Load Limit: 6 tons

- Wire Rope Size: 3/8" - 1/2"
- Weight: 15 lbs

P/N 700-20291 Crosby 599533

Synthetic rope may conduct electricity if inadvertent contact is made.

Samson Nylite™ Snatch Block



- Maximizes a two part lifting system without over stressing synthetic rope. Exclusive high strength sheave reduces weight while providing the proper radius and groove shape to eliminate rope wear. Swivel plate with locking bolt makes change over easy and fast.
- Hook swivels under no or low load conditions
- 1.5" hook opening with latch
- Fits 7/8" to 1 1/8" rope diameters
- 8 ton maximum workload
- Weighs 33 lbs.
- 23" overall length

P/N 0234-21054 Samson 915-321

Synthetic rope may conduct electricity if inadvertent contact is made.

Nylite™ Spool Shield & Shackle



- Easily installed into or removed from a pre-made soft eye and 1/7 the weight of metal thimbles
- Size 5 for 1 1/8" - 1 1/4" rope
- Will not deform or rupture from repeated loadings
- Shackle is designed to take full advantage of the high strength of the Nylite connector and synthetic rope

P/N 234-90004	964-160	.44" Diameter
P/N 234-90005	964-0680	.88" - 1.06" Diameter
P/N 234-90006	964-0680	.50" Diameter
P/N 234-90007	964-084	1.13" - 1.19" Diameter

1 Ton Swivel Hook



- Suitable for frequent rotation under load
- Used for material handling aerial devices
- 1" diameter hook opening

P/N 234-21042

Crosby 5 Ton & 8.5 Ton Swivel Hook



- All swivels individually proof tested with certification
- Suitable for frequent rotation under load
- Hooks furnished with latches assembled
- Other types and capacities, up to 600 tons, available to meet your requirements
- Suitable for digger derricks

P/N 234-21010	Crosby 297217	5 Tons
P/N 234-21007	Crosby 29741	8.5 Tons

Crosby Replacement Latch Kit



- Heavy duty stamped latch interlocks with the hook tip
- High cycle, long life spring
- Can be made into a "positive locking" hook when proper cotter pin is utilized
- Latch kits shipped unassembled with instruction

P/N 234-21048 Crosby 1096562 for 234-21010 Crosby 5 Ton Swivel Hook

DYNAMOMETERS

Dillon Mechanical Model AP Dynamometers



- Accuracy +/- 0.5% of full scale capacity for precise data
- Broad temperature range for use in nearly any environment
- No batteries required
- Large safety factor for overload protection
- Anti-parallax dial and pointer produce accurate readings from any perspective
- Maximum hand retains peak load point and is easily reset
- Standard Model AP Dynamometer includes: Dynamometer, shackles and pins, maximum pointer, zero adjust for tare, carrying case (molded plastic on 5" models or rugged plywood crate for 10" models) and calibration certificate

Part Number	Dillon Part #	Capacity & Dial Division in Lbs.	Diameter of Dial
9700-99329	30006-0027	1,000 x 10	5"
9700-94051	30006-0035	2,000 X 20	5"
9700-12731	30006-0084	10,000 x 100	5"
9000-99868	30006-0100	20,000 x 200	5"

Dillon Digital ED Extreme Dynamometer

- Superior strength and corrosion resistance
- 5:1 safety factor
- Typical accuracy of 0.1% of full scale capacity
- Exclusive soft-key interface and wide angle LCD
- Powered by (2) standard C-cell batteries
- Backlit display

P/N 9702-28968 36188-0032 2,500 lb. capacity



Dillon Digital ED Junior Dynamometer



- Can be relied upon for simple, yet critical measurements of weight and force
- Shares the same base of research and testing that was conducted to match material characteristics and load cell technology
- Typical accuracy of 0.1% of full scale capacity
- Exclusive soft-key interface and wide angle LCD
- Powered by (2) standard C-cell batteries

9700-60779 36190-0053 10,000 ft. lbs. x 10 lbs. Dial Division

Lincoln Hoist Tension Meter

Lincoln Hoist is pleased to introduce its new line of lineman's tension meters. The analog mechanical design (no batteries or LCD) improves performance in harsh conditions. LCDs often fail in cold climates, can be difficult to read in bright sunlight, and suffer from the constantly changing readings. Lincoln meters solve these issues, and are much smaller than competing mechanical designs. Standard units come with installed fittings ready to hook up to hoist and wire grip.

ALTEC Part Number	Lincoln Hoist Model #	Capacity (lbs.)	Graduation (lbs.)	A (in.)	B (in.)	C (in.)*	WT	WT2**
9700-90213	A10S	2,000	50	5 1/2	5/8	13	1 7/8	3 1/4
9703-89355	A-20S	4,000	100	6 1/2	5/8	14	2 5/8	4 1/8
9703-89356	A-30S	6,000	100	10	1 1/8	17 3/4	4 3/4	8

* C Dimension - Overall Length with End Fittings
** WT2 - Meter Weight Including End Fittings

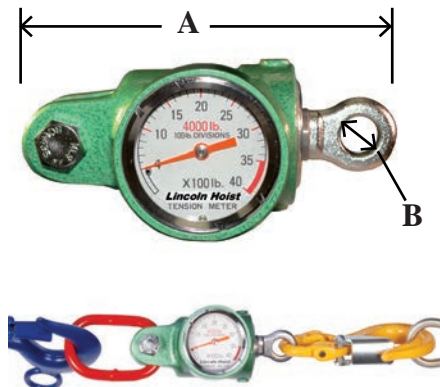

Grounds Tester



The Utility Solutions Grounds Tester provides a straightforward means of evaluating in service grounding assemblies. Complies with ASTM standards. Determine pass/fail criteria of various lengths of cable sizes #2 through double 4/0.

REACH Technology isolates the failure location so "failed" assemblies do not need to be scrapped. Requires a 20 amps, conventional 115 volt power outlet.

9703-35361	USGT-600	GROUNDS TESTER
9703-35362	USGT-600-15KVELBOW	15 kV LOAD BREAK ELBOW ADAPTER (FEMALE)
9703-35363	USGT-600-15KVBUSHING	15 kV LOAD BREAK BUSHING ADAPTER (MALE)
9703-35364	USGT-600-27KVELBOW	27 kV LOAD BREAK ELBOW ADAPTER (FEMALE)
9703-35365	USGT-600-27KVBUSHING	27 kV LOAD BREAK BUSHING ADAPTER (MALE)
9703-35366	USGT-600-SUB	3 1/8" OD SUBSTATION CLAMP ADAPTER

Load-Trainer™ Transformer Simulator

The Load-Trainer™ is a fully functional transformer trainer and simulator. Using real voltage, the two-piece portable trainer can recreate Delta-Delta, Delta-Wye, Open Delta-Open Delta, Wye-Delta, Wye-Wye, and even Wye (one leg out)-Open Delta transformer connections.

Hidden toggle switches allow instructors to simulate common infield problems like Low voltage bushing hook-ups, Polarity, Backfeed, High side phasing, Open primary, Open secondary, and more.

Three bushing and four bushing models available. Includes two heavy duty wheeled cases. Runs on conventional 110 VAC outlet.

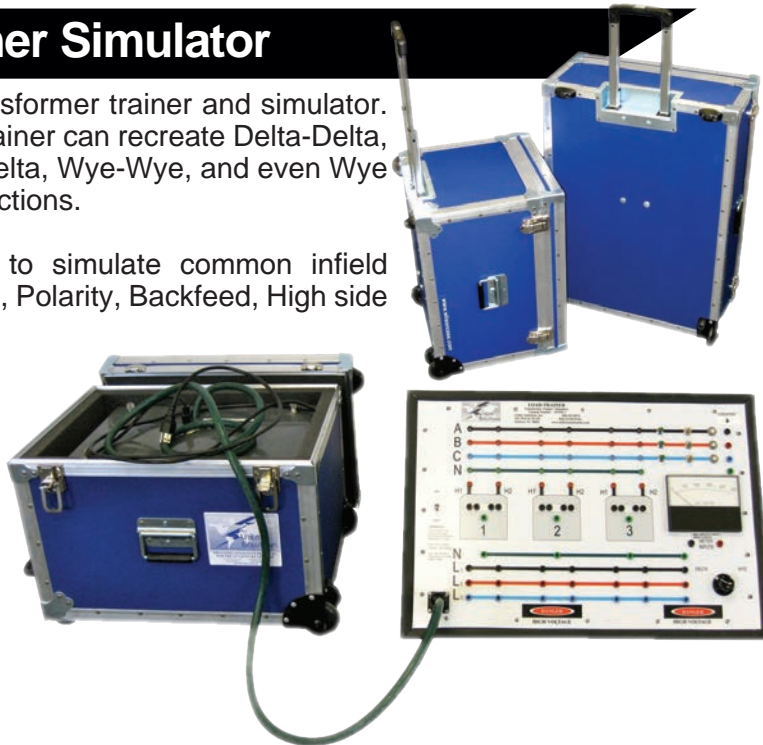

9703-35355	XFMR-3BUSHING	LOAD-TRAINER™ THREE BUSHING TRANSFORMER SIMULATOR
9703-35356	XFMR-4BUSHING	LOAD-TRAINER™ FOUR BUSHING TRANSFORMER SIMULATOR
9703-35357	XFMR-PRM	PHASE ROTATION METER
9703-35358	XFMR-LEADS	ASSORTMENT OF EXTRA BANANA LEADS
9703-35359	XFMR-3BUSHING-PRL	ADDITIONAL THREE BUSHING FRONT PANEL
9703-35360	XFMR-4BUSHING-PRL	ADDITIONAL FOUR BUSHING FRONT PANEL



Electrical

Test Equipment

Nothing But HEAVY DUTY®

ELECTRICAL TEST EQUIPMENT

USA: 1-877-GO ALTEC (1-877-462-5832)

www.alteconnect.com

ELECTRICAL COMBO KIT

- P/N 9701-99377 (2217-20) features true-RMS for accurate measurement in all applications; wide Voltage range to 600 AC/DC volts; High Contrast, White on Black Display with Backlight for easy reading; Lo-Z measurement to eliminate ghost voltage
- P/N 9703-62653 (2202-20) features wide 50 - 1000 AC voltage range with built-in LED light; Loud Beeper Indicates Voltage; CAT IV 1000V for highest safety available
- P/N 9702-99160 (48-22-1901): One handed blade opening - flip blade open up to 3X faster
- 48-22-2114: ECX™ Bit (patent pending) - Superior fit in Specialty Screws
- Includes: (1) P/N 9701-99377 2217-20 Digital Multimeter, (1) P/N 9703-62653 2202-20 Voltage Detector with LED, (1) P/N 9702-99160 48-22-1901 Fastback Utility Knife, (1) 48-22-2114 11 in 1 Multi-Tip Screwdriver, (1) 48-55-0175 Soft Meter Case, (1) Magnet Meter Holder, (1) Electrical Test Leads, (1) Thermocouple, (2) AA Batteries, (2) AAA Batteries, Manuals



P/N 9703-62653 2202-20

FORK METER



- Built-in LED work light and non-contact voltage detector
- High contrast, easy-to-read display; side-mounted dial
- Simplified user interface and feature set
- Rugged overmolding for durability and grip
- Includes fork meter, one test lead set, 2 AA batteries
- Current AC 200A, fork opening .63, TRMS, Safety rating Cat IV600V/Cat III 1000V, Voltage ACDC 1000V, Lo-Z measurement, resistance 40 Mohms
- Temperature range of -30° C - 800° C

P/N 9701-99378 2205-20

CLAMP METER

- 1.3" jaw opening with a thin jaw profile
- Simplified user interface; high contrast display
- Side-mounted dial for one-handed use
- Rugged overmolding for durability and grip
- Includes clamp meter, one test lead set, (2) AA batteries
- Features TRMS and built-in non contact voltage detector
- Safety rating Cat III 600V, Current ACDC 600A, Voltage ACDC 600V, resistance 6 Kohms, capacitance 400uF

P/N 9701-99376 2237-20



FLUORESCENT LIGHTING TESTER



- Test Lamps, Ballast and Pins: Complete 3-in-1 solution
- 2.5' Fully retractable antenna for extended reach when testing
- Non-conductive antenna sleeve allows for safe testing
- Removable antenna adapter improves lamp test response
- Visual and audible tool feedback to easily confirm testing
- Built-in LED flashlight illuminates dark work spaces
- Dial and buttons positioned for one-handed use
- Rugged over-molding for increased grip and durability
- Durable tool that continues to work after a 6.5 foot drop
- Includes (1) 2210-20 Fluorescent Lighting Tester, Soft Carry Case, Antenna Adapter Manual, (4) AA Batteries

P/N 9703-62973 2210-20

Tests Fluorescent Lamps, Ballast and Pins!



DIGITAL MULTI-METER



- High contrast, easy-to-read display, TRMS
- Simplified user interface and feature set
- Rugged overmolding for durability and grip
- Side-mounted dial; side rail for mounting voltage detector or magnetic accessories
- Includes multi-meter, one test lead set, one thermocouple (dual banana) (2) AA batteries
- Safety rating Cat III 600V, Voltage ACDC6 mV-600V, Lo-Z measurement, frequency 10Hz-50Khz, Resistance 40 Mohms, Capacitance 1000uF, Current ACDC 10A, contact temperature -40C to 400

P/N 9701-99377 2217-20

LASER DISTANCE METER

- Superior Design: Allows for easy measuring from edges and corners
- **P/N 9706-41551 2281-20** features 5 Measurement functions: length, area, volume, indirect measurement (Pythagoras), and stake-out
- **P/N 9706-41553 2282-20** features 7 measurements: length, Area, Volume, indirect measurement (Pythagoras), stake out, timer, and horizontal mode
- Simple Keypad and Interface
- Memory storage of last 10 measurements
- Kits include (1) Laser Distance Meter (2281-20 or 2282-20), (2) AAA Batteries, (1) Soft Carrying Case, (1) Quick Reference Card, (1) Manual

P/N 9706-41551 2281-20 200' Laser Distance Meter Kit; 5 Measurement Functions
P/N 9706-41553 2282-20 260' Laser Distance Meter Kit; 7 Measurement Functions



M12™ 160 x120 THERMAL IMAGER



- Crisp, High Resolution Thermal Images
- Complete Report Software easily analyzes images
- Broader Temperature Range (-10 to 350°C) to cover more applications
- 5X faster charge than closest competitor
- M12™ RED LITHIUM™ batteries allow for rapid field replacement
- 3.5" High Resolution LCD (640x480 pixel)
- Built-In Visual Camera and Flashlight
- Rugged overmolding for durability and grip
- Raised corners protect the LCD/thermal engine
- Hinged camera style lens cover is always attached so it will never be lost!
- Knurled focus ring is easy to grip with arc flash PPE
- All Thermal and Visual images use standard JPEG format
- Media door seals the included 2GB SD card, USB connections
- Includes (1) 2260-20 M12™ 160x120 Thermal Imager, **Thermal Imager Report Software (available online for free)**, 2GB SD Card, USB Cable, M12™ RED LITHIUM™ Battery Pack, 30 Minute Charger, SD Card Reader Carrying Case, Thermal Imager Manual, Software Manual, Quick Reference Guide Statement of Calibration

P/N 9703-29813 2260-21

M12 CORDLESS LASER TEMP-GUN™ THERMOMETER

- Built-in LED flood light
- High contrast, easy-to-read display
- Simplified user interface
- Rugged overmolding for durability and grip
- Lithium-ion battery pack
- Ergonomic pistol grip design
- Adjustable emissivity
- **P/N 9701-99372** features a 40:1
- **P/N 9702-16787** features a 12:1 cone measurement ratio for high accuracy measurements; basic accuracy is 1.5%
- **P/N 9701-99372** has min/max/avg/dif, 20 data storage points

P/N 9701-99372 2276-21 12V For -30° C to 800° C
P/N 9702-16787 2266-20 12V For -30° C to 500° C



**Please contact your Altec Supply Account
Manager for more information regarding
Milwaukee's quality Power Tools.**

GREENLEE ELECTRICAL TEST EQUIPMENT

CMGRT-100 Ground Resistance Tester



- Measures currents down to 1mA
- Reads ground resistance down to 0.10Ω
- Measures up to 30A RMS ground or leakage current
- Convenient alarm and 99-point memory functions
- Full autoranging with data hold to capture readings
- Includes (1) 9 volt battery, molded carrying case, test resistance loop

P/N 9000-99646 Greenlee CMGRT-100/07653

CMI-100 Industrial Clamp Meter



- High capacity 1000AAC/DC amperage measurement
- 600V AC/DC voltage, frequency, and resistance measurements for maximum versatility
- Continuity and diode tests with audible and visual indicators

P/N 9000-99654 Greenlee CMI-100/07564

CMT-80 Clamp-On Meter, 400A



- Automatic measurement of amperage, voltage, and resistance
- Compact design for measuring in tight spaces
- 400A AC, 600V AC/DC measurement
- Data hold to capture important readings
- Includes (1) 9 volt battery, test leads, carrying case

P/N 9700-39878 Greenlee CMT-80/07735

CM-950 AC/DC True RMS Clamp Meter



- AC/DC Amperage, AC/DC voltage measurement
- True RMS circuitry for no-compromise accuracy when harmonics are present
- Easy viewing, backlit display with analog bar graph
- Resistance measurement
- Frequency measurement in current mode
- Min/max feature for added versatility
- Includes (1) 9 volt battery, test leads, & carry case

P/N 9007-00950 Greenlee CM-950

CMI-200 2500A Industrial Clamp Meter



- True RMS for accurate measurement when harmonics are present
- 600V AC/DC voltage, frequency, and resistance measurements for maximum versatility
- Peak hold, min-max, relative offset, and analog bar graph to help monitor power changes
- High capacity 2500A DC, 2100A AC amperage measurement
- Auto power off for longer battery life

P/N 9000-99652 Greenlee CMI-200/07567

CM-600 AC Clamp-On Meter



- AC amperage and AC/DC voltage measurement
- Resistance measurement up to 2kΩ
- Auto power off for longer battery life

P/N 9705-59546 Greenlee CM-600/07593

CM-1350 True RMS Clamp Meter



- True RMS for the most accurate measurement when harmonics are present
- AC amperage, AC/DC voltage, frequency and resistance measuring capability
- Peak and Data hold to capture measurement
- Analog bar graph to view quick changes
- Audible continuity test
- Selectible auto off and min-max features
- 1000 A AC

P/N 9000-01350 Greenlee CM-1350/07733

CM-1550 1000A AC/DC True RMS Clamp Meter



- True RMS for the most accurate measurement when harmonics are present
- AC amperage, AC/DC voltage, frequency and resistance measuring capability
- Dual hall sensor
- Peak and Data hold to capture measurement
- Min/Max feature
- Analog bar graph to view quick changes
- Audible continuity test
- Selectible Auto off

P/N 9700-39884 Greenlee CM-1550/07799

Buried Line Locator



- LED and LCD signal strength indicators make it quick and easy to find the exact line location
- Automatic signal boost makes it easy to trace lines, even those with very weak signals

- Molded carrying case included
- Lightweight and ergonomically balanced
- Microprocessor-based circuitry delivers increased accuracy and features auto-gain control in all environments
- Traces 20' underground; provides depth readings up to 15'
- Transmitter can be connected to live lines up to 600V
- The receiver, which may be used in active or passive mode, locates multiple passive frequencies with one single setting; this feature automatically locks out passive range when it detects a transmitter signal, reducing the chance of tracing other lines that carry weaker signals

P/N 9700-39890 Greenlee BLL-200/07796

DM-300 TRMS Digital Multimeter



- Measures voltage, resistance, and continuity
- Excellent for measuring AC voltage of electrical circuits
- AC/DC voltage measurement
- Non-contact voltage detection
- Also features auto off, low battery indicator, resistance measurement, audible continuity and diode tests, data hold to capture measurement, 6000-count LCD, true RMS, and Min/Max feature

P/N 9701-38295 Greenlee DM-300

Gas Lamp Tester



- Tests most fluorescent lamps, low pressure sodium vapor, high pressure sodium discharge lamps, neon tubes, mercury vapor and metal halide lamps
- Gas lamp tester will also check starters, resistors, ignitors, capacitors, photo cells and non-electronic ballasts, and indicates AC/DC voltage and continuity

- Not for use with energy saving fluorescent lamps
- Includes detachable antenna, batteries, leads, probes, clamps and holster

P/N 9000-99658 Greenlee 5715/34529

CLM-1000 AND CLM-1000E Cable Length Meters

- Measures length of cable without removing it from the spool, counting turns or weighing the spool
- 20 pre-set cable sizes plus 8 user-programmable settings
- Pushbutton selection of Copper or Aluminum cable
- Measures cable length from 15.0 ft to 100.00 kft
- Measures resistance values down to 199.99 mΩ
- Displays length in feet or meters
- Measures insulated copper and aluminum conductors
- Large, 20,000 count LCD with backlight
- Automatic temperature compensation for maximum accuracy and convenience
- Automatic power off to maximize battery life
- Kelvin-type alligator clips with solid copper contacts assure low-resistance connection to the cable being measured

Altec	Greenlee	Wire Sizes	Length Measurement	Resistance Measurement
9705-89131	CLM-1000	18, 16, 14, 12, 10, 8, 6, 4, 2 AWG; 1/0, 2/0, 3/0, 4/0; 250, 350, 400, 500, 600, 750, 1000 kcmil	15.0 ft to 100.00 kft 5.0 m to 30.00 km (3 Ranges)	199.99 mΩ to 1999.9 Ω (5 Ranges)
9705-95629	CLM-1000E	0.75, 1, 1.5, 2.5, 4, 6, 10, 16, 25, 35, 50, 70, 95, 120, 150, 185, 240, 300, 400, 500 mm2		

GT-220 Electrical Tester



- Voltage measurement: 6.000 - 1000V
- Resistance measurement: 600.0 Ω - 6.000 MΩ
- Display: 6000-count LCD Measurement category: CAT IV, 1000v per IEC 61010-1; CAT III, 1000v per UL 61010B-1
- Includes a carry case

P/N 9700-39885

Greenlee GT-220/07748

GT-540 Multi-Function Electrical Tester



- Voltage measurement: 6.000 - 1000V
- Resistance measurement: 600.0 - 6.000 M
- Capacitance: 100.00, 1000.0 μF; 10.00, 100.0, 2000 F
- Display: 6000-count LCD
- Measurement category: CAT IV; 1000v per IEC 61010-1; CAT III, 1000v per UL, 61010B-1
- Includes a carry case

P/N 9700-39888

Greenlee GT-540/07749

Motor Rotation & Phase Sequence Indicator Kit



- Assists in correct motor installation by identifying the phases of a three-phase circuit and the rotation of an unenergized motor to prevent damage to motor or electrical system
- Identifies L1, L2, L3, phases and motor leads and indicates rotation of the motor before installation
- Easy clockwise and counterclockwise indication
- Case included

P/N 9000-99657 5779/07576 Complete Kit

P/N 9000-99655 5702/07574 Phase Sequence Indicator only

P/N 9000-99656 5123/34514 Motor Rotation Indicator only

P/N 9007-07534 TC-10/07534 Case for P/N 9000-99655

Megohmmeter



- Auto ranging AC/DC default voltmeter with test inhibitor and warnings for enhanced user safety
- Extra large digital display with backlight and analog bar graph
- Weather resistant against dust and water to IP44
- Measures up to 2000 MΩ resistance
- 250,500, and 1000V test ranges

P/N 9700-39886

Greenlee 5882/07573



9705-89131

GREENLEE ELECTRICAL TEST EQUIPMENT

GT-12 Non-Contact Self-Testing Voltage Detector



- Designed and assembled in USA
- Automatic self-test verifies the integrity of the unit
- Bright LED's and audible alarm sound if voltage is present
- Silent-mode feature for use in quiet settings
- Use to detect voltage in outlets, lighting fixtures, circuit breakers, wires, and cables or to find a break in a wire.
- Automatically turns off after five minutes of non-use to conserve battery life; low battery indicator
- Lifetime Limited Warranty

P/N 9702-16801 Greenlee GT-12/20947

GT-65 Voltage Tester



- AC/DC voltage and polarity measurement
- Continuity test and single probe detection of live conductors for added flexibility
- Overvoltage warning gives user visual notification that voltage levels have exceeded 1000V AC/ 380V DC
- Safe, non-contact voltage detection
- Auto-hold automatically activates when tester is removed from voltage reading
- Visual and audible continuity
- Voltage detection: 19 to 1000 VAC, 5 to 1000 VDC
- Frequency

P/N 9701-10614 GT-65/09025

GT-95 Voltage Tester



- Visual and audible continuity
- LCD and dual color LEDs
- Selectable SHAKER feature when measuring AC voltage
- Overvoltage warning gives visual notification that voltage levels have exceeded 1000V AC/380V DC
- Auto-hold automatically activates when tester is removed from voltage reading
- Continuity test and single probe detection of live conductors
- Safe, non-contact voltage detection
- GFCI test capability
- AC/DC voltage and polarity measurement
- Lifetime limited warranty
- Voltage Detection: 19 to 1000 VAC, 5 to 1000 VDC
- Frequency: 0 to 70 Hz
- GFCI: 7.5 mA at 120 VAC, +/- 10%
- Measurement Category: CAT IV, 600 V; CAT III, 1000 V

P/N 9700-39889 Greenlee GT-95/09027

DM-60 Digital Multimeter



- Designed for residential and light commercial use
- Includes elastomer boot to protect meter from damage
- AC/DC voltage; AC/DC amperage measurement
- Resistance measurement
- Audible continuity and diode tests
- Frequency measurement in voltage mode
- Data hold to capture measurement
- Max feature for added versatility
- Includes (1) 9V battery, test leads

P/N 9701-10615 Greenlee DM-60/12040 600V AC/DC

DMSC-2U Interface Kit



- Connects to a PC's USB or RS-232 (serial) port
- Allows real-time datalogging and graphing
- Export data to disk for analysis with any spreadsheet
- Includes RS-232 interface cable, USB converter, cable, and software

P/N 9702-17109 DMSC-2U

DM-200A, DM-210A, & DM-510A Digital Multimeter



- Measurement Category Rating CAT II 1000V, CAT III 600V, CAT IV 300V
- Auto-ranging or manual ranging selection
- BeepJack™ Safety Technology
- Two voltage detection modes – non-contact or using a single test lead
- Backlight
- Data Hold and Auto Power off features
- Computer interface capability

• Includes (2) AAA batteries and Test Leads

In addition to the DM-200A features, DM-210A also includes:

- Temperature and capacitance measurements
- Includes Type K thermocouple (200 C / 392 F max)

In addition to the DM-200A/DM-210A features, DM-510A includes:

- Low impedance AutoCheck™ mode—automatically selects AC or DC volts, resistance, or continuity. Low impedance masks "ghost" voltage pickup
- Min/Max/Average measurements
- Peak (crest) Hold – Max/Min
- AC True RMS

P/N 9000-99644 DM-200A/08740

P/N 9000-99643 DM-210A/08741

P/N 9702-16802 DM-510A/08742



CS-8000 Circuit Seeker™ Circuit Tracer

- Advanced patented non-directional sensing technology
- Superior sensitivity and functionality providing for accurate tracing and locating
- Traces concealed wiring, locates junction boxes, and finds breakers for live or open circuits
- Locates and identifies blown fuses
- Finds shorts and breaks in conductors
- Lifetime limited warranty

P/N 9702-16803 CS-8000

DML-430A Digital Logging Meter



- Measurement Category Rating CAT IV 1000V
- Low impedance AutoCheck™ mode - automatically selects AC or DC volts, resistance, or continuity. Low impedance masks “ghost” voltage pickup
- AC+DC True RMS
- Two Temperature inputs using a type K thermocouples
- Datalogging capability – stores 87,000 single-channel or 43,000 dual-channel measurements
- Dual digital display and analog graph
- 10,000 display counts
- Includes (1) 9V battery, test leads, and carrying case
- Includes Type K thermocouple (200 C / 392 F max)

P/N 9702-16805 DML-430A/08746

DM-810A, DM-820A, & DM-830A Multimeter Series



- Measurement Category Rating CAT IV 1000V
- AC True RMS capability
- BeepJack™ Safety Technology
- Auto-ranging or manual ranging selection
- Dual digital display and analog graph
- 10,000 display counts
- Computer interface capability
- Includes (1) 9V battery, test leads, and carrying case

P/N 9000-99641 DM-810A/08743

P/N 9000-50749 DM-820A/08744 (shown)

P/N 9702-16804 DM-830A/08745

In addition to the DM-810A features, the DM-820A also includes:

- One temperature mode using a type K thermocouple
- Two voltage detection modes – non-contact or using a single test lead

- Peak (crest) Hold – Max/Min
- Includes Type K thermocouple (200 C / 392 F max)

In addition to the DM-810A/DM-820A features, the DM-830A also includes:

- Low impedance AutoCheck™ mode—automatically selects AC or DC volts, resistance, or continuity. Low impedance masks “ghost” voltage pickup
- Two Temperature inputs using type K thermocouples
- AC+DC True RMS

DMSC-9U Interface Kit



- Connects to a PC's USB or RS-232 (serial) port
- Allows real-time datalogging and graphing
- Export data to disk for analysis with any spreadsheet
- Retrieves stored data from DML-430A
- Includes USB interface cable and software

P/N 9702-17110 DMSC-9U

DMHS-1



- A magnetic hanging strap for all Greenlee DMMs

P/N 9702-17111 DMHS-1

ELECTRICAL TEST EQUIPMENT

ELECTRICAL TEST EQUIPMENT

**USA: 1-877-GO ALTEC
(1-877-462-5832)**

www.alteconnect.com

Full Range Auto Ranging Voltage Indicator for Overhead & URD Systems

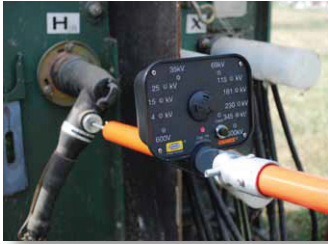

- Full Range (600V to 500kV)
- Eliminates the need for a selector switch
- Automatic ranging function quickly displays the approximate line-to-line voltage class
- An easy, yet reliable

means for the operator to determine if a line is: a) De-energized b) Carrying less than normal system voltage from any source or induced charged from an adjacent live circuit c) Energized at full system voltage

- Attaches to an Epoxiglas® insulating universal handle of appropriate length
- For overhead testing, a Shepherd Hook probe is included
- This model adapts to both overhead lines as well as URD circuits with 200 and 600 Amp elbows, including those with and without capacitance test-points
- Complies with OSHA 1910.269 to Test for Absence of Nominal Voltage
- Includes the tester unit, a shepherd hook probe, instruction manual and hard shell padded case.

P/N 9703-35038 PSC4032915
P/N 9700-96809 H1876-6S Shepherd Hook Probe
P/N 9700-57150 H1876-6 Straight Probes
P/N 9000-00428 T4030428 15 kV only Bushing Adapter
P/N 9007-40308 T4030856 15 -35 kV Elbow Adapter
P/N 9000-08570 T4030857 15 -35 kV Bushing Adapter

Extension Resistor Pair Extends Chance 16kV Phasing Testers for 48 or 80 kV Applications



- Designed to extend any Chance 16kV phasing tester for 48 or 80kV applications
 - Extension resistors simply thread in the field
 - 32" long
- P/N 9007-18762 H1876-2 up to 80kV**

Multi-Range Voltage Detectors



- Confirms that a line is de-energized prior to performing maintenance on it
- Gives a metered readout capable of distinguishing actual line voltage from static or feedover from an adjacent line
- Readings from an MRVD can be compared with numeric certainty rather than the subjective judgments associated with "fuzz-sticking" or "glow-detecting"

- Since the MRVD is not a voltmeter, no specific accuracy is claimed by the manufacturer nor can be assumed by the user
- Includes (1) carrying case, (1) hook probe, (1) straight probe*

P/N 9000-99664* C4030979 40kV MRVD
P/N 9000-99665 C4031029 16 kV

*Straight probe is only included with P/N 9000-99664

Multi-Range Voltage Detector with Illuminated Dial



- The lighted-dial option sets this unit apart from features standard on Multi-Range Voltage Detector P/N 9000-99664
- Actually a field intensity meter, the MRVD is calibrated to read approximate line-to-line voltage when connected to any phase

- conductor, responding to the magnitude of the field gradient between its end probe and floating electrode
- The MRVD gives metered readout capable of distinguishing actual line voltage from static or feedover from an adjacent line
- Readings from an MRVD can be compared with numerical certainty rather than the subjective judgments associated with "fuzz-sticking" or "glow-detecting"
- Since the MRVD is not a voltmeter, no specific accuracy is claimed by the manufacturer or can be assumed by the user
- The MRVD must be mounted on proper length hot stick for the voltage class involved
- Complete instructions are furnished with easy, illustrated step-by-step procedures
- Internal circuit and push button permit check before and after each use to confirm operational condition of instrument/battery

P/N 9701-06447 T403-3228 Voltage Indicator with Illuminated Dial
P/N 9700-96809 H1876-6S Shepherd Hook Probe
P/N 9700-57150 H1876-6 Straight Probes

Please contact 1-877-GO ALTEC (1-877-462-5832) for additional information regarding Chance products.

ELECTRICAL TEST EQUIPMENT

Standard Meter



- Determines phase relationships and approximate voltage, line-to-line, or line-to-ground
- Each tester consists of two fiberglass poles with end fittings threaded for interchangeable probes; probe fittings coupled with a high impedance component

encased in each pole, and, to complete the test circuit, a 22-foot length of insulated flexible cable stores on a reel affixed to one pole and connects to the voltmeter on the other pole

- Kit includes: Two 6' long x 1-1/4" dia. Epoxiglas® universal handles with storage bag, tester, hook probes, case and instruction manual

P/N 9000-99667 H1876 16kV Tester Kit
P/N 9700-92173 H18761 16kV Tester Kit with Case

115V Hot Stick Tester



- Portable unit makes easy work of testing insulated live-line tools
- Features wet and dry modes selected by a toggle switch and follows procedures specified by ASTM, IEEE, and OSHA
- Graduated meter gives precise readout of each tool's leakage current

- Can be used to test any length fiberglass-reinforced plastic hot stick up to 3" in diameter and offers convenience for spot checks at the jobsite or periodic diagnostics in the workshop
- Provides full scale test setups for both Wet 75kV-per-foot and Dry 100kV-per-foot in a compact, self-contained unit easily carried and operated by just one person
- Includes (1) tester, (1) instruction manual, (1) VHS videotape demonstration, (1) carrying case

P/N 9000-99671 C4033178

Protective Grounding Set Tester



- Self-contained and portable tester provides an easy way for an electric utility to check the resistance in protective grounding sets used by line personnel
- Powered by 120 VAC, the tester applies direct current across the test specimen
- A seven-minute videotape, included with each unit, shows how simple the tester is to use

- Procedure details are given in the instruction manual
- Includes: (1) self-contained carrying case, (2) ball stud terminals, (1) VHS demo videotape, (1) instruction manual, (2) troubleshooting probes, (1) self test cable

P/N 9000-99673 C4033220

Dual-Range Meters



- Toggle switch on the meter housing can switch calibration between the two scales on the meter face
- Improves readability for low-end values on the Hi (16kV) scale
- Switched to the Lo (5kV) range, those values deflect the needle more to give more finite readings

- Kit includes: (2) 6' long x 1-1/4" dia. Epoxiglas® universal handles with storage bag, tester, hook probes, case and instruction manual
- **P/N 9000-99666** also includes DC Hi-Pot Adapter, (2) bushing adapters and a Phasing Voltmeter Tester

P/N 9000-99668 T4032311 5 & 16kV Tester Kit*
P/N 9000-99666 T4032557 5 & 16kV Tester Kit**

* For distribution systems

**For overhead and underground systems

Digital Phasing Testers



- Large direct-reading display easily determines phase relationship and approximates voltage (line-to-line or line-to-ground)
- Push-button controls permit easy selection of options for display, such as backlight and hold features
- Sleep mode automatically conserves the battery when not in use
- Kit includes: two 6' long x 1/4" diameter Epoxiglas® universal handles with storage bag, tester, hook probes, case, instruction manual, two bushing adapters, one elbow adapter and a phasing voltmeter tester

P/N 9000-99669 C4033402 16kV Tester Kit*

P/N 9000-99670 C4033403 40kV Tester Kit

- P/N 9000-99669 also includes (1) DC Hi-Pot Adapter

ELECTRICAL TEST EQUIPMENT

**USA: 1-877-GO ALTEC
(1-877-462-5832)**

www.alteconnect.com

Please contact 1-877-GO ALTEC (1-877-462-5832) for additional information regarding Chance products.



HD ELECTRIC COMPANY
A Textron Company

DVI DIGITAL VOLTAGE INDICATORS

DVI Digital Voltage Indicators are single point instruments designed to read the voltage on a conductor. The large LED readout is easy to read on the end of a long hotstick and can be used on overhead lines or in underground applications with an underground bushing probe. The DVI-100 series indicate voltage up to 99kV, the DVI-500 series indicate voltage up to 500kV. Hotstick is required for use. The DVI-100T and DVI-500T with Test Point Mode has the added feature of indicating voltage on elbow test points.

- Large LED display indicates to line-to-ground voltage level
- Display is easy to read in bright or dark conditions
- Voltage readout allows the user to distinguish between nominal and induced voltages
- Audible indication when voltage is detected
- Use in overhead or underground applications
- Made in the USA

DVI-100 Model Kits

(DVI-100T Voltage Indicator Features Capacitive Test Point Mode)

P/N 9704-44065	DVI-100	DVI-100, HP-DVI-2, and CS-DVI
P/N 9704-44066	DVI-100T/K01	DVI-100T, HP-DVI-2, IEP-DVI-5 and CS-DVI
P/N 9704-44067	DVI-100T/K02	DVI-100T, HP-DVI-2, IEP-DVI-5, PT-DVI and CS-DVI
P/N 9702-97815	DVI-100/K01	DVI-100, HP-DVI-2, IEP-DVI-5 and CS-DVI
P/N 9701-08005	DVI-100/K02	DVI-100, HP-DVI-2, IEP-DVI-5, PT-DVI and CS-DVI

DVI-500 Model Kits

(DVI-500T Voltage Indicator Features Capacitive Test Point Mode)

P/N 9704-44068	DVI-500	DVI-500, HP-DVI-2, HP-DVI-6 and CS-DVI-5
P/N 9704-44069	DVI-500T/K01	DVI-500T, HP-DVI-2, HP-DVI-6, IEP-DVI-5, CS-DVI-5
P/N 9704-44070	DVI-500T/K02	DVI-500T, HP-DVI-2, HP-DVI-6, IEP-DVI-5, PT-DVI, CS-DVI-5
P/N 9704-44499	DVI-500/K01	DVI-500, HP-DVI-2, HP-DVI-6, IEP-DVI-5, CS-DVI-5
P/N 9703-21033	DVI-500/K02	DVI-500, HP-DVI-2, HP-DVI-6, IEP-DVI-5, PT-DVI, CS-DVI-5
P/N 9703-42455	DVI-500/K06	DVI-500, HP-DVI-2, HP-DVI-6, PT-DVI, CS-DVI-5

Accessories:

P/N 9703-42354	PT-DVI Proof Tester for Digital Voltage Indicators
P/N 9703-42350	IEP-DVI-5 Underground Bushing Probe, 15, 25 & 35 kV Class
P/N 9704-44071	HP-DVI-2 Overhead Hook Probe, 2" Diameter Opening
P/N 9704-44072	HP-DVI-6 Overhead Hook Probe, 6" Diameter Opening
P/N 9704-44073	CS-DVI-5 Rugged Plastic Case for DVI-500
P/N 9704-44074	B-30 Carrying Bag with Reflective Safety Stripes, Carrying Strap
P/N 9704-44075	HSA-2500 Universal Hotstick Adapter (Shotgun)
P/N 9702-52237	S-4H 4' Fixed Length Fiberglass Hotstick
P/N 9704-44500	S-6H 6' Fixed Length Fiberglass Hotstick

UNIVERSAL DIGITAL VOLTMETER

The DVM-80UVM is a compact, high accuracy dual stick voltmeter and phasing set with capacitive test point mode, peak hold and connecting cord. The DVM-80UVM measures voltage from 5V up to 40kV and up to 80kV with a pair of optional add-on resistors. The two-stick design can be used in both overhead and underground applications. The DVM-80UVM incorporates Phase Accurate Technology, which makes all voltage readings, whether made from line-to-line or line-to-ground, accurate and repeatable to within 1%.

A Universal Voltmeter Kit is available for the DVM-80UVM that includes: dual stick phasing voltmeter with overhead hook probes, add-on resistor sticks for measurements up to 80kV, underground bushing probes, cable fault tester, voltmeter proof tester, shotgun hotstick adapters, and a soft-sided, multifunctional carrying bag with built-in bucket hooks.

- Digital meter – reads in kilovolts, 3.5 digits with decimal point
- Highly accurate – within 1% of reading
- Voltage range – 5V-40kV, 5V-80kV with add-on resistors
- Auto-ranging – no range selector switch
- Backlit display – for easy reading in bright or dark conditions
- Peak hold mode – conveniently keeps the peak voltage reading on the display
- Measures both AC and DC through 1000Hz AC RMS
- Made in the USA



Made in the USA

Model DVI-100

For Voltages up to 161kV
(Reads up to 99kV Line-To-Ground)

- Large two-digit LED display indicates the line-to-ground voltage level

Model DVI-500

For Voltages up to 800kV
(Reads up to 500kV Line-To-Ground)

- Large LED display indicates the line-to-ground voltage level



Made in the USA

Take Measurements On:
Secondary Voltages Starting At 5 Volts
Primary Voltages Up To 80 Kilovolts
Elbow Test Points With Test Point Feature

P/N 9704-05501 DVM-80UVM Tool Only

P/N 9704-13671 DVM-80UVK Kit

Kit Includes:

- (1) Dual Stick Phasing Voltmeter (DVM-80UVM)
- (2) Overhead Hook Probes (025-OLPS-5)
- (2) Resistor Sticks For Measurements Up To 80kV (R-80)
- (2) Underground Bushing Probes (ASP-15/25)
- (1) Cable Fault Tester (CFT-35)
- (1) Voltmeter Proof Tester (PT-5000B)
- (2) Shotgun Hotstick Adapters (HSA-2500)
- (1) Soft-Sided, Multi-Functional Carrying Bag

ELECTRICAL TEST EQUIPMENT

USA: 1-877-GO ALTEC
(1-877-462-5832)

www.alteconnect.com





HD ELECTRIC COMPANY
A Textron Company

PRX PROXIMITY VOLTAGE DETECTOR

The PRX Proximity Voltage Detector is a non-contact detector. When voltage is detected, the PRX gives an audible and visual indication, with a typical detection distance of 10 inches. The PRX has the ability to detect voltage on elbow test points at the 120V setting. With a rechargeable internal battery, the PRX can be charged quickly from a 115-240V outlet or 12VDC automotive outlet. The PRX is sealed to resist water penetration in typical outdoor environments, providing maximum protection.



Made in the USA

Model PRX-69D (7) Standard Voltage Ranges from 120V to 69kV
Model PRX-500 (9) Standard Voltage Ranges from 120V to 500kV

- Sealed to resist water penetration in typical outdoor environments
- Loud beeper and LED lights indicate voltage
- Rechargeable battery with quick recharge
- Lightweight - weighs less than 1 pound
- Easy to use electronic touch pad with large buttons
- Detects voltages typically 10" from the source
- Heartbeat signal assures that PRX is ready to detect voltage
- Dual hotstick connections - universal spline & shotgun stick
- Detects voltage on most elbow test points
- Made in the USA



PRX-69D Model Kits

(Indicates Distribution Voltages from 120 VAC up to 69 kV with Rechargeable Battery):

P/N 9704-44076	PRX-69D/K01	PRX-69D, PRX-CORD
P/N 9704-44077	PRX-69D/K02	PRX-69D, PRX-CORD and PRX-XF
P/N 9704-44078	PRX-69D/K03	PRX-69D, PRX-CORD, PRX-XF, and B-2
P/N 9704-44079	PRX-69DH	PRX-69D, PRX-HS, PRX-CORD and PRX-XF
P/N 9704-44080	PRX-69DB	PRX-69D, PRX-HS, PRX-CORD, PRX-XF and B-2
P/N 9702-80266	PRX-69D	PRX-69D, PRX-HS, PRX-CORD, PRX-XF, PRX-CS

PRX-500 Model Kits

(Indicates Trans & Dist Voltages from 120 VAC up to 500 kV with Rechargeable Battery):

P/N 9704-44081	PRX-500/K01	PRX-500, PRX-CORD
P/N 9704-01503	PRX-500/K02	PRX-500, PRX-CORD and PRX-XF
P/N 9704-44082	PRX-500/K03	PRX-500, PRX-CORD, PRX-XF and B-2
P/N 9703-21812	PRX-500H	PRX-500, PRX-HS, PRX-CORD and PRX-XF
P/N 9704-44083	PRX-500B	PRX-500, PRX-HS, PRX-CORD, PRX-XF and B-2
P/N 9702-80266	PRX-500	PRX-500, PRX-HS, PRX-CORD, PRX-XF, PRX-CS

Accessories:

P/N 9704-44084	PRX-CORD
P/N 9704-44085	PRX-XF
P/N 9704-44086	PRX-HS
P/N 9704-44087	PRX-CS
P/N 9704-44088	050-00300-PRX

Charge Cord with 12VDC Automotive Jack
115-240 VAC Transformer to Plug PRX-CORD into 115-240 VAC Wall Outlet
Carrying Holster with Belt Clip, Restraining Strap
Carrying Case; Holds PRX, PRX-HS, Charge Cords
Rechargeable Battery Replacement Kit; Contains Replacement Battery, Overlay Label, Instructions Padded, Zippered Carrying Bag with Strap; Holds PRX, PRX-HS and Charge Cords

P/N 9704-44089 B-2

V-Watch Personal VOLTAGE DETECTORS

Worn on the outside of your clothing at mid-torso, V-Watch® Personal Voltage Detectors provide that extra level of safety by detecting and alerting you to the presence of electrical fields or energized electrical equipment. In emergencies, you and your crews can move in safely to quickly restore power to your customers.

- Alerts user to proximity of high voltage
- Audible and visual alarms increase in frequency the closer the user gets to energized equipment
- Typical V-Watch warning distance is about 7 feet (2.13 m) from a 4kVAC conductor
- Provides another level of safety for storm restoration workers and first responders
- Lanyard allows user to adjust to optimum mid-torso position
- Can be used on 50Hz and 60Hz systems
- Made in the USA

P/N 9704-91901	VW-20HFR
P/N 9705-88598	VW-20HFR-K
P/N 9705-88599	VWP-20HFR
P/N 9705-88600	VWP-20HFR-K
P/N 9704-93285	VW-20H
P/N 9705-88601	VW-20H-K
P/N 9705-88602	VWP-20H
P/N 9705-88603	VWP-20H-K
P/N 9705-88604	C-10FRVW
P/N 9705-88605	C-10FRVWP
P/N 9703-08028	C-10VW
P/N 9705-88606	C-10VWP
P/N 9705-88607	VW-K-BAG

V-Watch Personal Voltage Detector; C-10FR Flame Resistant Carrying Case Lanyard
V-Watch Kit includes VW-20HFR, C-10FR and VW-K-BAG
V-Watch Pro Personal Voltage Detector (Mute Button); C-10FR Flame Resistant Carrying Case Lanyard
V-Watch Pro Kit includes VWP-20HFR with C-10FR and VW-K-BAG
V-Watch Personal Voltage Detector with C-10 Carrying Case Lanyard
V-Watch Kit includes VW-20H with C-10 and VW-K-BAG
V-Watch Pro Personal Voltage Detector with mute button and C-10 Carrying Case Lanyard
V-Watch Pro Kit includes VWP-20H with C-10 and VW-K-BAG
High-Visibility Safety Green Shielded, Flame Resistant Carrying Case With Built-In Lanyard; Includes Instruction Card For VW-20
High-Visibility Safety Green Shielded, Flame Resistant Carrying Case With Built-In Lanyard; Includes Instruction Card For VWP-20
Black Shielded Carrying Case Lanyard (Built-In Lanyard); Instruction Card For VW-20
Black Shielded Carrying Case Lanyard (Built-In Lanyard); Instruction Card For VWP-20
Zippered Carrying Bag Holds V-Watch Unit, Carrying Case Lanyard And Instruction Manual



Made in the USA

ELECTRICAL TEST EQUIPMENT

USA: 1-877-GO ALTEC
(1-877-462-5832)

www.alteccconnect.com



HD ELECTRIC COMPANY
A Textron Company

HVA HIGH VOLTAGE DIGITAL AMMETER

The HVA-2000 is a high voltage digital ammeter designed for taking AC current measurements up to 2000 amps and on transmission and distribution system voltages up to 500kV. The large, bright display allows the current measurement to be read from a long distance while storing the last 4 readings. This eliminates the need to bring the unit back down for each reading.

- Use on both distribution and transmission systems
- Accuracy 1% of reading
- Display is easy to read from a distance and in bright or dark conditions
- Small and lightweight, easy to manage on an extension hotstick – 1.8 lbs (0.82 kg)
- Quickly take current readings on conductors up to 500kV (phase-to-phase)
- Stores the last four readings
- Use in overhead and underground applications
- Take spot-load checks with ease
- Verify phases are balanced
- Auto shutoff with low battery function
- Dual hotstick connections – universal spline and clampstick
- Nylon zippered carrying bag included
- Use on conductors up to 2.75" (7.0 cm)
- Measures AC current, 25-500Hz
- Made in the USA



Made in the USA

P/N 9705-88612 HVA-2000: High Voltage Digital Ammeter, 0-2000 AMPS AC with Large Digital Display, Holds Last 4 Readings; Includes B-5 Carrying Bag

P/N 9705-88613 B-5: Zippered Carrying Bag for HVA

P/N 9705-88614 CS-HVA : Rugged Plastic Carrying Case for HVA-2000

THREE PHASE CABLE IDENTIFIER

The 3ID Three Phase Cable Identifier identifies the correct phases on long lengths of de-energized and discharged overhead and underground cables. It includes a sender and receiver that are designed to be hand held with or without gloves. Because of its higher test voltage, the 3ID can test up to 7 miles (11 km) of cable. LED's on both units indicate that the 3ID units are connected to the same phases on each end of a cable.

- Identify all three cable phases simultaneously and any shorted phases
- Higher test voltage of 36VDC allows for longer cable lengths to be tested – minimum one mile (1.6 km)
- Use in overhead or underground systems
- Compact, lightweight and easy-to-use
- Super bright LED indicators
- Large copper alligator clips with heavy duty boots
- Low battery indicator
- Made in the USA



Made in the USA

P/N 9705-88615 3ID-100: Three Phase Cable Identifier (Sender, Receiver, B-5 Bag)

P/N 9705-88613 B-5: Zippered Carrying Bag

LV-5 STRAY VOLTAGE DETECTOR

The Stray Voltage Detector, model LV-5, is used to detect stray voltage as low as 5 volts which may be present on any electrically conductive surface such as street light poles, guide guy wires, wood transmission poles, meter cans, manhole covers and many other metallic surfaces in and around electrical utilities.

- Low threshold voltage sensing design picks up voltages from 5VAC to 600VAC with direct contact and above 600VAC at a distance
- Tester integrated into the holster provides a visual indication of the test. Supplies a low voltage AC signal for testing before and after use
- Ultra bright, long-lasting red LED indicates when voltage is present
- Rugged, utility-grade design is waterproof
- Detector is always on, ready to use and operates on two AA alkaline batteries
- Optional Extension Handle extends the LV-5 reach
- Optional Ground Shield used in areas where energized conductors are present and interfere with normal voltage tests
- Operating Frequency 60Hz
- Made in the USA



Made in the USA

P/N 9705-88608 LV-5/K01 Stray Voltage Detector, Detects Stray Voltage from 5-600VAC; Kit Includes LV-5, Holster and Integrated Tester

P/N 9705-88609 LV-5 Stray Voltage Detector, Detects Stray Voltage from 5-600VAC

P/N 9705-88610 LV-GS Ground Shield

P/N 9705-88611 LV-EH Extension Handle



ELECTRICAL TEST EQUIPMENT

USA: 1-877-GO ALTEC
(1-877-462-5832)

www.alteconnect.com

KLEIN TOOLS®



Committed to manufacture the highest quality hand tools with unmatched durability and comfort for over 155 years

ELECTRICAL TEST EQUIPMENT

USA: 1-877-GO ALTEC
(1-877-462-5832)

www.alteccconnect.com

Professional Voltage / Continuity Tester

CL1000 400A AC Clamp Meter



- Large clamp opening
- Capacitance great for HVAC work
- Display is brighter than most competitive units
- Worklight lights clamp area
- Magnetic mount secures meter and frees hands
- Side-mounted dial for ease of use
- Lead storage protects leads
- CAT III 600V Rating
- Frequency/duty cycle
- Bar graph measures fast moving readings
- Non-contact voltage tester

P/N 9702-48297 CL1000

MM500 Auto Ranging Multimeter



- User-friendly three button design to measure continuity, resistance and voltage
 - Voltage automatically detects AC or DC -- Measures up to 750V
 - Includes both visual and audible continuity indicators up to 25Ω
 - Resistance range: 4000Ω
 - Auto-Hold captures the first stable displayed value
 - Auto ranging
 - Self storing leads perfectly spaced for easy measurements of tamperproof outlets
 - 4000 count LCD display
 - Other features include brighter display / back light, low battery indicator and auto power off
 - Battery door with captive screws for easy battery replacement
 - Test leads and batteries included
 - Optional accessories available: carrying case and replacement leads
- IP 67: Dust and water proof
 - 10 foot / 3 meter drop protection
 - CAT IV safety rating for 600V

P/N 9706-41368 MM500

MM1000 Electrician's Multimeter



- Auto ranging voltage measurement
- Backlit display
- Analog bar graph
- Measures AC/DC Voltage - 1000V
- Measures AC/DC Current - 10A
- CAT IV safety rating for 600V
- 6 foot / 1.83 meter drop protection
- Includes test leads, batteries, and thermocouple

P/N 9706-41442 MM1000

PD25[®] Phasing Digital 25kV

- Completely Shielded Interconnect Cable (Insulated 35kV to Ground), that Does NOT Have to be Held Off of Grounded or Live Objects for Fear of Shock or Interfering with the Reading
- Multiple Ranges 2kV, 20kV, 25kV
- Interconnect Cable Lengths up to 100ft.
- Patented Input Circuitry
- The Most Accurate High Voltage Meter Available, with Accuracy to +/- 1%
- Both Probes are Impact and Water Resistant Designed to Withstand Wear
- Both Probes are Stored in Either a Highly Durable Padded Carrying Case or a Canvas Bag
- Extension Resistors available for voltages up to 75kV

The PD25 is a 0-25kV all-in-one phasing voltmeter with numerous applications.

P/N 9702-48180 Bierer PD25



Patented technology

PD800W[®] Phasing Digital Wireless

The PD800W[®] Cordless Phasing Tester accurately and easily operates in multiple applications including **phasing, voltage detection, phase sequencing and phase angle indication**. You will only need this one kit for three-phase secondary systems, capacitive test points, URD systems and overhead and transmission/substation systems. This unique tester operates like a conventional phasing tester, but **does not require an interconnecting cable or extension resistors**.

- FCC Licensed Wireless Technology
- Large Easy-to-Read Digital Display with Backlight
- Both Probes feature High Intensity Color Coded LED Indicator Lights
- Both Probes are Impact and Water Resistant, Designed to withstand Wear
- Both Probes are Completely Shielded to Minimize Stray Field Interference
- Cordless; Direct Contact from 120V - 69kV, Distribution Systems
- Cordless; (Degree Position Only) Non-Contact from 69kV - 800kV, Transmission/Substation Systems
- Automatically Alerts User of a Delta/Wye Transformation by an Indicator Light Blinking
- Operating Range of 100ft.

P/N 9702-99717 Bierer PD800W



Patented technology

Phasing Ranger 1[™] GPS Phasing Tool

No other phase identification device is easier to use when it comes to determining actual phase relationship in the field. All readings are **Real Time** readings, there are no calculations to be made or data to be transferred from one location to another.

This **Smart Grid** Technology requires a **One Time** set-up procedure and then allows the user a permanent and reliable means of phasing, phase ID, mapping and tagging or general troubleshooting.

- Absolute Phase Identification
- Mapping & Tagging
- All General Phasing
- Phase Sequence CW/CCW
- URD and Overhead
- Flags Delta/Wye, Wye/Delta Transformations
- Simultaneous use of multiple Field units
- Usable from 120V to 765kV

P/N 9702-48176 Bierer PR1COMP



Patented technology

VDA040P™ Analog Voltage Detector 40kV

The VDA040P is a Dual Application Analog Voltage Detector.

- Detects 0-40kV Line to Ground (0-69kV Phase to Phase)
- A Proximity or Direct Contact on Overhead and Underground Systems
- Easy to Read Analog Scale
- Detect Voltage from the Ground on Bare Overhead Lines when Hand Held
- Test Secondary Voltage on Bare or Insulated Cables
- Test Capacitive Test Points
- Indicates Line to Ground Values for Nominal or Induced Voltages
- The 5 - Position Selector Switch is Calibrated for Height above Ground to Compensate for a Capacitive Coupling Effect
- Shielded to Minimize Stray Field Interference
- For Your Safety, the Detector Includes Overload Protection up to 500kV
- Internal Backlight available for Night Use
- Water Resistant, and a Strong Construction Designed to Withstand Wear
- Contained in a Highly Durable Padded Carrying Case

P/N 9702-48181 Bierer VDA040P



AV Meter™ Audible/Visual Voltage Indicator

The AV Meter is a Voltage Indicator with an Audible and Visual Alarm to indicate the presence of voltage, with an operating range from capacitive test points/secondary voltage to 289kV Line to Ground (500kV Phase to Phase). Activation thresholds meets ASTM Requirements.

- Up to 12 available voltage settings that are completely customizable
- Meter Assembly is Over Voltage Protected
- Incidental Direct Contact Will Not Damage the Unit
- Watertight Construction
- Fully Repairable for a Low Cost of \$75 after 1 year Free Replacement Warranty Expires
- Bright LEDs and Loud Horn Guarantees Operator Seeing & Hearing Unit
- Built in Test Position is Standard for All Units
- May also be Used as a Direct Contact Voltage Detector
- Standard Universal/Grip All Adapter is Included with Every Unit

P/N 9702-48220 Bierer AV40



ST500™ Service Tester 500 Amps

The ST500PGN puts a high magnitude pulse between the neutral/hot leg or hot leg/hot leg for any secondary service (120V, 208, 277, 480V). It cannot be fooled by telephone and cable television bonding often missed by continuous loading devices.

- Identify bad conductor(s) from the transformer to the meter base
- Indicate integrity of neutral conductor to prevent excessive house ground currents
- Locate both hot legs and neutral at the pedestal and/or transformer blocks.
- Locate bad connectors on overhead spans
- Identify de-energized URD Primary cable in a manhole or ditch
- Feed IN/OUT on primary URD transformers, switches, and riser poles

P/N 9703-09641 Bierer ST500PGN

ST800™ Service Tester 800 Amps

The same great features as the ST500 but with an 800 Amp capacity.

P/N 9704-87878 Bierer ST800PGN



Patent pending



HASTINGS

A WORLDWIDE SUPPLIER OF
Hot Line Tools & Equipment

Electrical Instruments

ELECTRICAL TEST
EQUIPMENT

USA: 1-877-GO ALTEC
(1-877-462-5832)

www.alteconnect.com

Regulator Neutral Detector



- Insures that the operator has the regulator in its neutral position prior to disconnecting the regulator from the circuit
- Eliminates high or low

voltages caused by cycling the regulator to the upper or lower limits, then counting steps back to neutral

- Works with step type and induction type regulators up to and including 34.5KV systems
- 0 - 2000 volt range is shown in one volt increments
- No range selector is required
- Digital display with 1/2" tall LCD digits for easy viewing
- Lighted meter can be switched on by the operator
- 9 volt battery included; features low battery indicator
- RND verifies the step indicator has not slipped one step
- A female universal spline allows unit to be attached to all universal hot sticks
- Contact electrodes are knurled to aid contact with conductors

P/N 9700-67625 6709-1 Regulator Neutral Detector Complete With Case, Battery, And Instructions

Phase-Tell III Wireless Phasing Meter

- Determines phase relationships on three phase power systems, overhead and URD applications
- Wireless units communicate up to 300 feet apart without the need to identify transmitter or receiver
- FCC Compliant
- Auto Shut-Off
- Rugged extruded aluminum enclosure
- Voltage range from URD test points to 500KV
- Each unit operates on two "AA" batteries, included
- Automatic test cycle when placed in the "On" position
- Includes carrying case and instructions



- P/N 9702-79738 6722 Phase-Tell III Wireless Phasing Meter
- P/N 9702-79737 266 URD Bushing Well Adapter

P/N 9702-79738 6722 Phase-Tell III Wireless Phasing Meter
P/N 9702-79737 266 URD Bushing Well Adapter

Transformer And Capacitor Tester



- Test new transformers, capacitors to ensure they are not shorted or open prior to energizing; detects failures in equipment before loading and transporting to the job site
- Trouble shoot in-service units
- Powered by a 9 volt battery
- Can be used to -40° C
- Contact electrodes are knurled to aid in contact with conductors
- Magnetized back allows hands to be

free to install and remove cables and clips

- Four bright LED lights signal the condition of the equipment being tested
- Housing is weatherproof, high-impact resistant plastic

P/N 9700-98209 6793

Non-Contact Voltage Detector



- Exclusive Static discriminator technology provides more reliable detection on low voltage ranges, and now means no more false alarms
- All in one universal attachment and a shotgun adapter in the handle

- Electronic touchpad includes 11 range settings from 240v to 230KV and 2 URD settings, 15KV and 25KV
- Includes (3) C cell batteries
- Built in self test function, High quality beeper, Water resistant design
- Auto power off, Low battery indicator
- Operator feedback - both visual and audible
- Less than 1 pound
- The RND verifies the step indicator has not slipped one step
- Female universal spline allows unit to be attached to all universal hot sticks
- Contact electrodes are knurled to aid in contact with conductors

Digital Voltage Phasing Meter



- Measures overhead and underground voltages
- Digital display reads directly in kilovolt with three 1/2" high digits; the readout is given to the nearest 100 volts
- Digital display has a lighted background

that operates via a switch

- Powered by a 9 volt battery - included. Low battery indicator
- Meter shuts off automatically after 10 minutes without contacting live voltage
- Coiled, self-retracting cable; 16" retracted, 10' fully extended
- Complete with storage case, which also accommodates a pair of add-on resistor extensions, 2 bushing adapters, and a Hi-Pot adapter (each sold separately)
- **P/N 9007-06702** Unit includes: Digital volt meter, conductor hooks, carrying case, battery, and instructions

P/N 9007-06702 6702 0-40KV Digital Volt Meter

P/N 9007-67021 6702-1

(1) 15/25Kv Loadbreak Bushing Adapter

P/N 9701-75507 6702-2

(1) D.C. Hipot Adapter For Up To 35Kv

P/N 9701-31308 6702-3

(1) 35Kv* Loadbreak Bushing Adapter

P/N 9701-75507



P/N 9701-31308



P/N 9007-67021

MISCELLANEOUS TESTERS & EQUIPMENT

Hastings Phase-Tell III Wireless Phasing Meter



- Battery powered, two-piece wireless phasing tool
- Determines phase relationships on three phase power systems, overhead and URD applications; when contact is made with line voltage or elbow test points, the Phase-Tell III units compare transmitted data and then display the results via Red or Green LED lights and differentiated audible signals.

Flashing green lights indicate In-Phase. Flashing red lights indicate Out-of-Phase.

- Wireless units communicate up to three hundred feet apart.
- Both units are identical, no need to identify transmitter or receiver
- Voltage range from URD test points to 500KV
- Both units confirm the same phase readings
- Rugged extruded aluminum enclosure
- Each unit operates on two "AA" batteries, included
- FCC Compliant
- Automatic test cycle when placed in the "On" position
- Auto Shut-Off
- Includes carrying case and instructions
- URD bushing adapters and case available

P/N 9702-79738 6722 Phase-Tell III Wireless Phasing Meter

P/N 9702-79737 266 URD Bushing Well Adapter

Salisbury Voltage Detectors & Kits



- Verifies presence of voltage with an extra-bright LED light and an audible signal
- Includes 3 "C" batteries, shotgun adapter, and a case
- May be used with rubber insulating gloves or hotsticks using the splined universal end fitting

VOLTAGE DETECTOR:

P/N 9701-06454 4244 240v TO 230kV Detector

P/N 9701-06455 4344 240v TO 500kV Detector

P/N 9700-55973 4444 240v TO 69kV Detector

COMPLETE KIT:

Includes (1) Detector (indicated below), (1) P/N 9700-93070 Shotgun Adapter, and (1) P/N 9700-67482 Case

P/N 9000-99676 4356 Includes (1) P/N 9701-06454 240V to 230kV Detector

P/N 9007-04367 4367 Includes (1) P/N 9701-06455 240V to 500kV Detector

P/N 9007-04469 4469 Includes (1) P/N 9700-55973 240V to 69kV Detector

AVAILABLE INDIVIDUALLY:

P/N 9700-67482 4315 Storage Case

P/N 9000-99678 P/N 9700-93070 2500 Shotgun Adapter

P/N 9000-99678 4445 Voltage Detector Detector

Direct Contact Voltage Detector



- For system voltages up to 69kV
- 9-volt alkaline battery operated
- Carrying case included
- Compact, lightweight, easy to use
- Emit both audible, visual indications
- Designed for overhead applications, but can be adapted for underground use with optional underground bushing probes
- Rugged polycarbonate housing
- All-check self testing system
- No on/off or range selector switches
- Built-in universal spline (for hot stick attachment)

- Physically contacts conductor under test
- Optional bushing probes for underground applications

Altec Part	HD Electric	Description
9701-13459	TAG-200	Detector, Plastic Case
9701-00978	TAG-200/KIT	Detector, Probes, Case
9701-13460	TAG-200MR	Detector, Plastic Case
9701-13461	TAG-200MR/KIT	Detector, Probes, Case
9701-13463	IEP-UD/C	Underground Bushing Probe (15/25/35 kV class)

Salisbury Self-Testing Voltage Detector



- Verifies live or de-energized conductors
- May be used with rubber insulating gloves or hot sticks using the splined universal end fitting
- 4.5 volt transistor amplifier with audio/visual indicator
- Recommended that the tester be moved closer to conductor until warning is indicated, or it touches the conductor, apparatus, or test point

VOLTAGE DETECTOR:

P/N 9701-06448 4544 240v TO 230kV Detector

P/N 9701-06449 4644 240v TO 500kV Detector

P/N 9700-89931 4744 240v TO 69kV Detector

COMPLETE KIT:

Includes (1) Detector (indicated below), (1) P/N 9700-93070 Shotgun Adapter, and (1) P/N 9700-67482 Case

P/N 9000-99677 4556 Includes (1) P/N 9701-06448 240V to 230kV Detector

P/N 9701-06450 4667 Includes (1) P/N 9701-06449 240V to 500kV Detector

P/N 9000-04769 4769 Includes (1) P/N 9700-89931 240V to 69kV Detector

AVAILABLE INDIVIDUALLY:

P/N 9700-67482 4315 Storage Case

P/N 9700-93070 2500 Shotgun Adapter

ELECTRICAL TEST EQUIPMENT

USA: 1-877-GO ALTEC
(1-877-462-5832)

www.alteconnect.com

MISCELLANEOUS TESTERS & EQUIPMENT

ELECTRICAL TEST EQUIPMENT

USA: 1-877-GO ALTEC
(1-877-462-5832)

www.alteconnect.com

K-3 Phase Sequence Indicator



- Identifies the phase sequence (A-B-C or C-B-A) of three-phase voltages
- Rotating disk design
- Internal connections are soldered
- Leads are color-coded and 36" each
- Operates from 25-60 hertz and 60-600 volts

P/N 9700-46336

Fluke Clamp Meter (Large Display)



- Ergonomic clamp meter, shaped to fit your hand and access tight spots easily
- Features a large display that is backlit so readings can be taken in virtually any lighting situation
- Auto-shut-off maximizes battery life

P/N 9700-96197 334A

Fluke T5-600 Electrical Tester

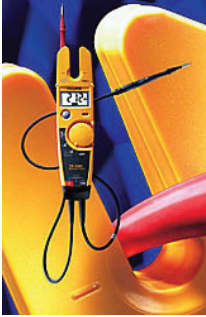

- Checks voltage, continuity and current
- Displays resistance to 1000Ω
- Compact design with neat probe storage
- Auto off mode to conserve battery life
- Rugged enough to withstand a 10' drop
- Stay connected much longer than with a solenoid type tester
- Detachable SlimReach™ test probes are customized for national electrical standards
- Test leads accept optional accessories such as Fluke accessory test clips and specialty probes

specialty probes

- Automatically measures AC/DC Volts with precise digital resolution
- OpenJaw™ current lets you check current up to 100A - without breaking the circuit

P/N 9701-04690 T5-600-USA

IDEAL 760 Series TightSight® Clamp Meter w/TRMS, Capacitance, Frequency



- 660 A True RMS clamps for a variety of industrial and commercial environments
- Unique TightSight® bottom display makes hard-to-reach measurements convenient
- Easy-to-read displays feature large numbers and green glowing backlight
- CAT IV rating for maximum safety
- Frequency, capacitance, peak, data hold, max/min

P/N 9702-91124 61-763

HD ELECTRIC TAG-330 Direct Contact Voltage Detector



- 9-volt alkaline battery operated
- Metal carrying case included
- For distribution and transmission system voltages 69kV - 765kVAC (phase-to-phase)
- Physically contacts conductor under test
- Emit both audible and visual indications when placed in contact with an energized conductor
- Designed for overhead applications, but may be adapted for underground use with optional underground bushing probes
- Rugged polycarbonate, water-resistant, gasketed housing for heavy field use
- Features an all-check self testing system, no on/off or range selector switches, and a built-in universal spline for hot stick attachment

P/N 9000-00348 TAG-330 Single Range

HD Electric PRX-500 Proximity Voltage Detector



- A non-contact voltage detector with nine selectable voltage ranges from 120 VAC up to 500 kVAC
- Provides an audible and visual indication of voltage detected from elbow test points up to the highest transmission voltages
- Features an easy-to-use electronic touch pad with large buttons
- Rechargeable internal battery that can be quickly charged from your truck or a wall outlet - a quick 15 minute charge provides over one full day of use
- A full charge takes only 3 hours and gives 1 week of continuous use
- Nine standard voltage ranges from 120 VAC up to 500 kVAC
- Detects voltages 10" or greater from source and most elbow test points
- Weighs less than 1 pound
- Loud beeper and LED lights indicate voltage
- Made in the USA
- Can be used on 50Hz and 60Hz systems

P/N 9702-80266 PRX-500 PRX-500 only
P/N 9703-21812 PRX-500H PRX-500 with Holster

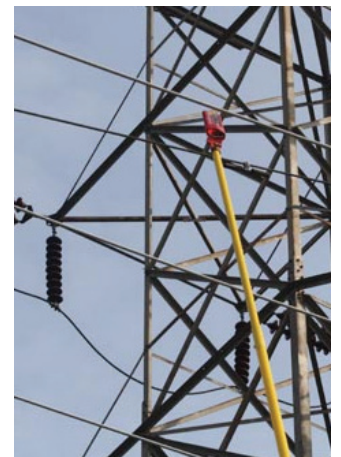

Nicholson No. 14 Silver Flash Pruner

- Heavy-duty
- Preferred by utility crews and tree surgeons
- Silver Steel® constructed blade, flat ground
- Concave cutting edge has precision set and bevel filed teeth
- Teeth cut fast on the pull stroke
- Extra large teeth and gullets for speed cutting large limbs
- Wood handle
- Full cardboard sleeve protects blade

P/N 9705-16566 80299 No. 14 Silver Flash Pruner

Nicholson No. 420 Tuttle Tooth Pruner

- All-purpose saw for general pruning
- Special steel constructed blade
- Teeth designed for fast cutting of large limbs and firewood
- Wood handle
- Full cardboard sleeve protects blade

P/N 9705-16568 80309 No. 420 Tuttle Tooth Pruner

Campbell Nylon Block for Manila Rope

P/N 9705-16570 7220214 P/N 9705-16571 7222213 P/N 9705-16572 7222214

- P/N 9705-16570 features a loose swivel hook with latch "G"
- P/N 9705-16571 features a loose hook with latch "F"
- P/N 9705-16572 features a loose swivel hook with latch "G"
- Nylon shells and sheaves
- Fittings are drop-forged
- Plated strap and connections
- Order unit is "Each"

Altec P/N	Model	Sheave Style	Rope Dia.	Working Load Limit
9705-16570	7220214	2" Single	3/8" - 1/2"	500 lbs.
9705-16571	7222213	2" Double	3/8" - 1/2"	1000 lbs.
9705-16572	7222214	2" Double	3/8" - 1/2"	1000 lbs.

Nicholson No. 20 Curved Pruner

- General-purpose pruner for fast cutting of small limbs
- A favorite in citrus groves and vineyards
- Silver Steel® constructed blade with polished finish
- Easy-to-grip knife-type wood handle trimmed with aluminum screws
- Full cardboard sleeve protects the blade

P/N 9705-16567 80263 No. 20 Curved Pruner, 14"

Nicholson Double Edge No. 316 Pruner

- Lightweight, economy pruner
- Dual-purpose pruner
- Special steel constructed blade
- Fine teeth on one edge for light trimming
- Teeth on opposite edge for heavier limbs
- Wood handle
- Plastic sleeve for blade protection

P/N 9705-16569 80269 Double Edge #316, 16"

Nicholson 12" Combination Bow / Hack Bowsaw and Hacksaw

P/N 9705-16573 80777 P/N 9705-16574 80799

- Two saws in one! Hi-Viz Orange
- Comes with two blades
- Hacksaw for metal and plastic, a bowsaw for wood and general yard work
- Built-in hand safety guard helps prevent injuries
- Hacksaw blade: Long-lasting high-speed steel
- Full 6" throat makes cutting plastic pipe easy
- Includes safety blade guard for storage
- Bowsaw blade cuts in both directions

P/N 9705-16573 80777 Hi-Vis Frame

P/N 9705-16574 80799 Black Frame

P/N 9705-16575 80814 Replacement Blade

Campbell Grade 30 Log Chain



- Made from System 3 chain with grab hook one end, slip hook other end
- Self-colored finish
- Packed one 14 foot length in a bag; 2 bags per box
- Order unit is "each"

P/N 9705-16576 1005505 3/8" x 14'

LUFKIN TAPES

ARBORIST EQUIPMENT

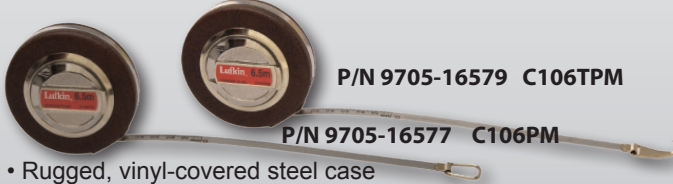
Lufkin 10mm x 6m Artisan® Diameter Tree Tape Chrome Clad®



- Rugged, vinyl-covered steel case
- Chrome Clad® and Nubian® blade
- .008" thick blade
- Large easy winding drum and friction washers
- Nylon rollers guide the tape smoothly in and out of case

P/N 9705-16577	C106PM	Without Claw Hook
P/N 9705-16578	C106PMCAL	Calibrated Tape with Ring
P/N 9705-16579	C106TPM	Features Claw Hook

Lufkin 3/8" x 20' Artisan Diameter and Tree Tape

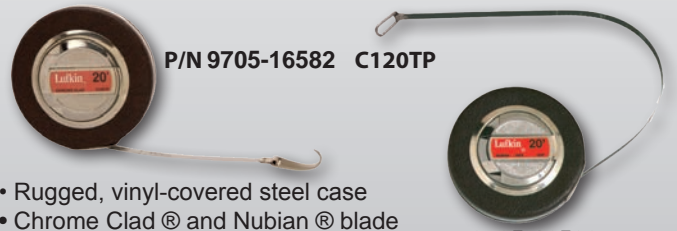

- Rugged, vinyl-covered steel case
- Chrome Clad® and Nubian® blade
- .008" thick blade
- Large easy winding drum and friction washers
- Nylon rollers guide the tape smoothly in and out of case
- P/N 9705-16581 and P/N 9705-16582 each feature a special claw hook designed for anchoring in tree bark
- Blade style: B10

P/N 9705-16580	120P	Without Claw Hook
P/N 9705-16581	120TP	Claw Hook
P/N 9705-16582	C120TP	Claw Hook & Chrome Clad®

Lufkin 1/2" x 100' Hi-Viz® Orange Fiberglass Tape, Feet & Inches



- Open four-arm frame design protects blade, does not trap dirt in case
- Lightweight but strong case is easy to handle and rewind
- Two-material grip is comfortable to use
- Hi-Viz® orange case is easy to find on the job site
- Folding end hook for true-zero measurements
- Feet and inches graduated to 8ths; numbered feet and instantaneous feet
- Yellow clad fiberglass blade impervious to moisture
- Blade style C1

P/N 9000-00387	FE100	100 Ft Length
P/N 9705-16583	FE200	200 Ft Length
P/N 9705-16584	FE300	300 Ft Length

NICHOLSON FILES

Nicholson 8" Flat Chainsaw File, Code No. 18



- American pattern flat chainsaw file
- Used for cutter-raker type (2 round edges) chain saw
- Rectangular shape

P/N 9705-16585 02215N8" Length

Nicholson 8" Chainsaw Depth Gauge File, Code No. 211



- American pattern depth gauge chainsaw file
- Rectangular shape
- Single cut, safe edges
- Length shown is overall length of file

P/N 9705-16586 02244N8" Length

Nicholson Double-Ended Taper File

- American pattern taper file, regular
- Triangular shape
- Single cut
- Tapers slightly towards the point
- File supplied with handles



P/N 9705-16587	02884M	6" Length
P/N 9705-16588	02905M	7" Length
P/N 9705-16589	02926M	8" Length

www.alteconnect.com

USA: 1-877-GO ALTEC
(1-877-462-5832)

Plumb 24 oz. Hickory Ball Pein Hammer

- Ground, black head
- Polished poles and peins
- Quality hickory handle
- Permabond® construction between head and handle

P/N 9705-16590 11520 15" Length

Plumb 48 oz. Drilling Hammer

- Black forged head
- Hickory handle
- Wood wedged for easy handle replacement
- Recommended for striking cold chisels and brick chisels
- Also for punches, and star drills
- Known as the "stone cutter's" hammer

P/N 9705-16592 11649 10.75" Length

Plumb 20 oz. Expert California Lath Hatchet

- Full polished head
- Checkered striking face
- Thin blade
- Hickory handle
- Permabond® construction between head and handle

P/N 9705-16595 11544P 12.5" Length

Plumb 36 oz. Hickory Broad Hatchet

- Black epoxy finish on head
- Heavy hatchet has broad, single-bevel, cutting edge
- Hickory handle
- Permabond® construction between head and handle

P/N 9705-16597 11554 15.5" Length

Plumb 24 oz. Fiberglass Ball Pein Hammer

- Rust-resistant, forged black head with polished poles and peins
- Professional quality fiberglass handle
- Permabond® construction between head and handle
- Comfortable black cushion grip

P/N 9705-16591 11428 15" Length

Armstrong Double Face Sledge Hammer

- Made in the USA - quality and availability
- Dropped forged head from alloy steel finished in black with polished faces and bevels
- Large face commonly used with slugging / striking wrenches, stone, concrete, and metal
- Striking face has substantial bevels to reduce the chance of chipping
- Hickory handle is flame-treated, clear-lacquered, and securely wedged into the hammer head
- Meets or exceeds ASME B173.3

P/N 9705-16593 69-647 1.75" Face Diameter, 16" Handle

P/N 9705-16594 69-653 2.5" Face Diameter, 36" Handle

Plumb 30 oz. Hickory Half Hatchet, Octagon Pole

- Durable, black epoxy finish on head
- Octagon-shaped pole
- Hardened, tempered bit holds sharp cutting edge
- Hickory handle
- Permabond® construction between head and handle

P/N 9705-16596 11549 13.5" Length

Plumb 28 oz. Rigster Hatchet

- Full polished head
- Checkered face
- Sharp cutting edge
- Hickory handle
- Permabond® construction between head and handle

P/N 9705-16598 11559P 18" Length



KLEIN TOOLS®



Committed to manufacture the highest quality hand tools with unmatched durability and comfort for over 155 years

Arborist Equipment

Tree Climbers with 2-3/4" Gaffs Without Pads and Straps

- Secure sleeve and leg iron connection. Two slotted hex-head bolts with lock washers and barrel-type nuts join the steel sleeve and leg iron together
- Steel split ring secures ankle strap in place and allows for quick replacement
- 4-7/16" wide stirrup provides greater foot support
- Adjustable climber length steel sleeve moves in 1/4" increments for the most comfortable fit
- Contoured leg irons help position gaffs securely and comfortably
- Extra-long gaffs for maximum penetration when climbing trees.
- To determine size needed, measure from instep to 1" below knee
- Sold in pairs only

P/N 9700-78336 Klein 1907AR 15" - 19" Adjustable Length
 P/N 9701-31087 Klein 1907ARL 17" - 21" Adjustable Length
 P/N 9704-17968 Klein 7 Replacement Gaff



Ankle Straps for Pole and Tree Climbers



- Durable neoprene-impregnated nylon strap is chemical/abrasion resistant and non-conductive
- Tongue buckle has roller for easy adjustment and a comfortable leather buckle pad
- Sold in pairs only

P/N 9000-53020 Klein 5301-20

Climber Straps for Pole and Tree Climbers



- Durable neoprene-impregnated nylon strap is chemical/abrasion resistant and non-conductive
- Tongue buckle has roller for easy adjustment and a comfortable leather buckle pad
- Sold in pairs only

P/N 8001-00017 Klein 5301-18

Gaff Sharpening Kit for Pole and Tree Climbers

- Contains the following:
 (1) 8" Fine-tooth File, (1) 3" Honing Stone, (1) Gaff Gauge, (1) Fully-illustrated gaff sharpener instructions, (1) Handy roll-up canvas case with tie

P/N 9701-59000 KG-2



Snap-On Gaff Guard



- Coil-spring, plastic coated guard quickly snaps onto pole climbers
- Sold in pairs only

P/N 9000-01972 Klein 1972G

Knives

Lockback Pocket Knives



9700-99480



9701-22728



9703-30473



9700-72338

- Compact and durable, fitting comfortably in your pocket
- Opens quickly and safely with one hand via a textured thumb stud
- Corrosion resistant, premium quality AUS 8 stainless steel blades, 58-59 Rc.
- P/N 9700-99480 is also available in brushed silver (P/N 9700-96131)

P/N 9700-99480 44001-BLK 2 1/2" Drop Point Blade
 P/N 9701-22728 44002 2 3/8" Drop Point Blade
 P/N 9700-72338 44005 2 5/8" Sheepfoot Blade, Lightweight
 P/N 9703-30473 44006 2 5/8" Sheepfoot Blade
 P/N 9700-99480 44008 2 1/2" Drop Point, Screwdriver Blades

Deerskin Work Gloves

- Premium deerskin, soft and form-fitting for maximum comfort
- Gunn cut with seams away from wear surfaces
- Inseam index finger
- Shirred-elastic wrist back
- Natural light-tan color

P/N 9706-40779 40020 Small
 P/N 9706-40780 40021 Medium
 P/N 9706-40781 40022 Large

Deerskin Work Gloves - Lined
 P/N 9702-88947 40016 Medium
 P/N 9702-88952 40017 Large
 P/N 9706-40782 40018 X-Large



Lineman's Backpack

- Wide opening easily accommodates other equipment
- Large front pocket for separate storage of gaffs, rubber gloves or other equipment
- Durable, double stitched plastic bottom with drain holes
- Adjustable padded shoulder straps with adjustable chest strap
- Padded back area

P/N 9704-34710 5185ORA



PROUDLY MADE IN THE



Ultra-Premium Black Vinyl Equipment Bag



- 24"L x 18"H x 10"W
- Hard rubber base
- Nylon-web handles extend down the side of the bag for extra support
- Convenient, Velcro fastening, water-proof flap for quick bag open and closure in the rain
- Two heavy duty slide-action buckles for convenient, secure bag closure
- Two large outside pockets with Velcro enclosure
- Comfort padded, adjustable shoulder strap
- Wide opening steel frame is securely riveted in top of bag

P/N 9702-89118 5182BLA



Quality Equipment for Professional Lineworkers

New York Tree Saddle

- This all nylon web saddle has "D" rings on the waist belt and butt strap
- The cushion section is 3" wide
- The tongue buckle is leather backed, and the snap and "O" ring are standard

P/N 9705-16672 Bashlin 637-S Small (32"-38" Waist)
 P/N 9705-16673 Bashlin 637-M Medium (36"-42" Waist)
 P/N 9705-16674 Bashlin 637-L Large (40"-46" Waist)
 P/N 9705-16675 Bashlin 637-XL X-Large (44"-50" Waist)



California Tree Saddle

- This saddle features 3" nylon cushion material lined with leather for comfort
- The tongue buckle section is rugged six ply, neoprene coated nylon
- "D" rings are provided on the hips and butt strap
- The leather straps are soft and comfortable

P/N 9701-31085 Bashlin 669-S Small (34"-42" Waist)
 P/N 9702-92984 Bashlin 669-M Medium (37"-45" Waist)
 P/N 9000-70065 Bashlin 669-L Large (41"-49" Waist)
 P/N 9705-16676 Bashlin 669-XL X-Large (44"-52" Waist)



Pennsylvania Tree Saddle

- Patented Back-A-Line waist belt, for comfortable support
- Modular design for added versatility
- Double D-Ring center anchor
- Individual leg straps

P/N 9705-16677 Bashlin SMTSIBS+LA-S Small (34"-42" Waist)
 P/N 9705-16678 Bashlin SMTSIBS+LA-M Medium (37"-45" Waist)
 P/N 9705-16679 Bashlin SMTSIBS+LA-L Large (41"-49" Waist)
 P/N 9705-16680 Bashlin SMTSIBS+LA-XL X-Large (44"-52" Waist)



Adjustable Positioning Lanyard with Cam Adjuster

- Bashlin's 4016NX Adjustable Positioning Lanyard features an easy to use friction adjuster, light carabiner for connecting to the belt and a red core for easy inspection and indications of wear
- It is lightweight and measures 8 feet long

P/N 9702-29424 Bashlin 4016NX-8



Adjustable Positioning Lanyard with 90 Degree Cam Adjuster

- Bashlin's 4016NX Adjustable Positioning Lanyard features an easy to use friction adjuster, light carabiner for connecting to the belt and a red core for easy inspection and indications of wear
- It is lightweight and measures 8 feet long

P/N 9703-61919 Bashlin 4019NX-8



Aluminum Alloy Tree Climbers

- Designed for Tree Climbing and features a 2 1/2" gaff
- Reduces fatigue and adds climbing comfort
- Comparable steel climbers weigh 30% more
- Climbers come with bottom straps attached, top straps and P/N 9000-08142 pads
- Weighs 5.75 lbs.

P/N 9701-82523 Bashlin BD-14T-1N Lower Straps Attached
 P/N 9701-82510 Bashlin BD-14T-2N Upper and Lower Straps Attached
 P/N 9000-93059 Bashlin BD-14T-5N Upper and Lower Straps and 140DS Pads

Bashlin BD14T



BD-16BT

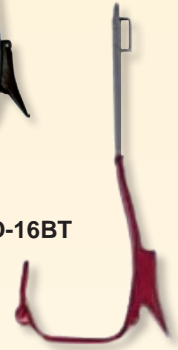

Rugged Steel Alloy Tree Climbers

- Designed for Tree Climbing and features a roomy ankle area and replaceable gaff

P/N 9702-92987 Bashlin BD-16BT-1N Lower Straps Attached (4.9 lbs.)
 P/N 9705-16681 Bashlin BD-16BT-2N Upper and Lower Straps Attached (6 lbs.)
 P/N 9705-16682 Bashlin BD-16BT-4N Upper and Lower Straps and 130D Pads (7 lbs.)
 P/N 9705-16683 Bashlin BD-16BT-5N Upper and Lower Straps and 140DS Pads

145 Series Climber Pads

- Features extreme comfort and gives increased climber support
- Double strap design with "spur stay irons"
- Fits Bashlin steel and aluminum climbers
- One pair climber straps included with pads

P/N 9700-91312 Bashlin 145 Without steel insert
 P/N 9700-91310 Bashlin 145AC For Steel Climbers
 P/N 9700-91311 Bashlin 145BC For Aluminum Alloy Climbers
 P/N 9700-91310 Bashlin 145ACVW For Hook-N-Loop Steel Climbers
 P/N 9700-91311 Bashlin 145BCVW For Hook-N-Loop Aluminum Alloy Climbers



P/N 9700-91310

P/N 9700-91310 and P/N 9700-91311



Adjustable Rope Sling

- Yalex Adjustable slings are ideal for hanging transformers or other equipment
- There is little stretch, and the orange coating resists abrasion and mechanical damage

P/N 9702-54292 Bashlin 960Y

Safe Working Load:
 Vertical: 3205 lbs.
 Choker: 2560 lbs.
 Basket: 6405 lbs.



11DC Coated Nylon Gear Bag



- This is our largest bag. It is made of very tough waterproof polyester material and has nylon web handles
- It has a leatherette bottom and flap to cover the opening when exposed to weather
- The "S" model features a polyester web shoulder strap
- 24" X 19" X 11"

P/N 9700-92826 Bashlin 11DC No Strap
 P/N 9701-27995 Bashlin 11DCS Includes Strap



Quality Equipment for Professional Lineworkers

662AC HARNESS



- Bashlin body harnesses are Arc Flash rated, per ASTM Standards
- They are available in the standard "H" style. 662 series, and "X" style that are more comfortable and have a front loop for self-rescue, or fall protection when using climbing devices
- The 662 Series is a fully adjustable, one-size-fits-most full body harness, in the "H" style. Size XL and larger are available. This harness also has a dorsal seat strap and 10,000 lb test web. The full range of back attachment options are available.
- Bashlin's 662AC is an "H" Harness with 24" extension back attachment and a D-Ring; the maximum lanyard length is 4'

P/N 9705-16684 Bashlin 662AC-O One Size Fits Most

Polyester Shock Absorbing Lanyard



- The 2804 series tubular nylon lanyards have a shock absorbing core that eliminates the need for a bulky pack
- These devices meet ANSI Z359.1 performance standards
- The snaphooks have 3/4 inch openings and high strength gates
- The complete unit complies with the ASTM F887 Arc Flash standards
- The standard length is 6 feet

P/N 9701-81780 Bashlin 2804-4HL 4' Length
 P/N 9705-16685 Bashlin 2804-5HL 5' Length
 P/N 7054-00562 Bashlin 2804-6HL 6' Length

Leather Pruning Hand Saw Guard/Scabbard & Axe Guards



- Made of durable russet leather
- Riveted at all points of strain
- Leather straps are used to keep the guard in place
- An "O" ring is provided for attachment to Tool Saddles

P/N 9705-16686 Bashlin 610 Leather Saw Guard - Straight 26"
 P/N 9705-16687 Bashlin 610A-24 Leather Saw Guard - Curved 24"
 P/N 9705-16688 Bashlin 610A-26 Leather Saw Guard - Curved 26"
 P/N 9705-16689 Bashlin 613A Leather Axe Guard

2022 Aerial Waist Belt



- An aerial belt designed with a sliding dee ring that provides user with maximum mobility
- The 5-1/2" pad and waist strap are both made of strong neoprene

impregnated nylon

- Waist strap has 9 adjustment holes
- Meets ANSI standards

P/N 9705-16599	2022-S	Small
P/N 8939-40080	2022-M	Medium
P/N 9705-16600	2022-L	Large
P/N 9705-16601	2022-XL	X-Large

Buckingham Aerial Waist Belt with Single Floating "D" Ring without Woven Back Pad



- Aerial waist belt alternative model for the 3852 comes without the woven back pad
- Made of 1 3/4" woven nylon sewn to a man-made synthetic material for wear
- The billet end of the strap has 7 grommet holes for adjustment

- Single floating dee ring provides the user with maximum mobility

- Meets ANSI standards

P/N 9705-16607	3808-S	Small (28" - 32")
P/N 9702-40951	3808-M	Medium (32" - 36")
P/N 9704-08234	3808-L	Large (36" - 40")
P/N 9704-08237	3808-XL	X-Large (40" - 44")

High Elevation Self Rescue System



- Provides all components necessary for self-rescue or aiding in rescuing a fellow employee
- The descender stops the user until the handle is compressed allowing for a smooth, controlled descent; also stops if the handle is

compressed too hard (50' 1/2" braided rope)

P/N 9000-10150 101SR-50



Rescue Buck

- The Rescue Buck is ideal for aerial rescue training, made of heavy cordura nylon, individual compartments can be filled with buckmix to desired weight
- Nylon retention straps are sewn to mid section to prevent body belt from sliding
- 5' 6" H.

P/N 9702-36519 694

5919 Aerial Waist Belt



- Aerial waist belt with a 5" wide back support lined with soft top grain liner leather
- Waist strap is 1-3/4", 6-ply neoprene impregnated nylon that supports a floating dee ring
- Aerial belts should not be used

where the fall potential is more than two feet

- The billet end of waist strap has 9 adjustment holes

- Meets ANSI standards

P/N 9705-16602	5919-XS	X-Small (24" - 28")
P/N 9705-16603	5919-S	Small (28" - 32")
P/N 9705-16604	5919-M	Medium (32" - 36")
P/N 9705-16605	5919-L	Large (36" - 40")
P/N 9705-16606	5919-XL	X-Large (40" - 44")

Buckingham Aerial Waist Belt with Single Floating "D" Ring



- Aerial waist belt with single floating dee ring that provides the user with maximum mobility
- 1 3/4" woven nylon sewn to a man-made synthetic material for wear
- A 3" wide soft woven pad is attached

- Billet end of the strap has 7 grommet holes for adjustment
- Model 3808 available without woven back pad.

- Meets ANSI standards

P/N 9705-16608	3852-S	Small (28" - 32")
P/N 9704-78047	3852-M	Medium (32" - 36")
P/N 8938-03660	3852-L	Large (36" - 40")
P/N 9705-16609	3852-XL	X-Large (40" - 44")

Hurt Man Bucket Truck Rescue System



- Ideal for lifting a hurt man easily and quickly
- Pulleys are made of stainless steel and have a 4:1 lifting advantage
- 95' of 7/16" diameter rope that can support a load up to 1700 lbs.

- Designed to mount permanently and high up on the boom

P/N 9000-99605 3813

P/N 9000-50550 3813D1 Features Strap and D-Ring

Buck Self Rescue System



- Ideal for the one man crew!
- Provides the means to safely and easily descend to the ground in the event of a fall from the bucket or the need to evacuate an inoperable bucket
- This systems combines a specially designed bag that, when deployed, releases a ladder [to relieve pressure], an ascender, descender and 50' of rope
- Longer lengths available upon request
- Rated to 330 lbs.

P/N 9702-08468 106-50



PREMIUM CLIMBING LINES

ARBORIST EQUIPMENT

USA: 1-877-GO ALTEC
(1-877-462-5832)

www.alteconnect.com

ArborMaster® (Model 348)

This durable 16-strand line is the result of collaboration between Samson engineers and professionals at ArborMaster® Training ArborMaster® offers the maximum firmness for all climbing techniques. Its 1/2" diameter provides an easy grip, and it has low stretch and excellent knot-heat resistance. Spliceable at both ends without milking.

- Firm
- High Visibility
- Low Stretch
- Sized For Easy Grip
- Excellent Knot-Holding Capability
- Heat Resistant
- Flexible
- Spliceable At Both Ends



ArborMaster® Splice



Red/Black/White



Gold Streak



Blue Streak

ROPE DIA.	MODEL 348	120' IN A POLYBAG (SPLICED)	120' IN A POLYBAG (UN-SPLICED)	150' IN A POLYBAG (SPLICED)	150' IN A POLYBAG (UN-SPLICED)	200' IN A POLYBAG (SPLICED)	200' IN A POLYBAG (UN-SPLICED)	600' ON A REEL (SPLICED)
1/2"	RED / BLACK / WHITE GOLD STREAK BLUE STREAK	9705-45606 9705-45607 9705-45608	9705-45609 9705-45610 9705-45611	9705-45612 9705-45613 9705-45614	9705-45615 9705-45616 9705-45617	9705-45618 9705-45619 9705-45620	9705-45621 9705-45622 9705-45623	9705-45624 9705-45625 9705-45626

Arbor-Plex (Model 346)

The first synthetic rope designed specifically for the arborist industry, Arbor-Plex is a lightweight, high strength 12-strand climbing line, and the most widely used rigging line in the arborist industry. It resists snags and has excellent knot-holding ability. Arbor-Plex works well when wet and is very durable.

- Durable
- Snag-Resistant
- Works Well In Wet Conditions
- Economical
- Has A No-Twist Stripe

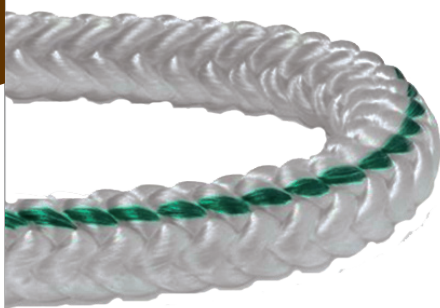

ELASTIC ELONGATION		
10%	20%	30%
3.00%	3.30%	4.20%

After 50 cycles at % of break strength

DIAMETER (INCHES)	WEIGHT PER 100 FT (POUNDS)	AVERAGE STRENGTH (UNSPLICED)	WORKING LOAD (UNSPLICED)
1/2"	6.8 lbs.	6,000 lbs.	1,200 lbs.
5/8"	12.0 lbs.	9,000 lbs.	1,800 lbs.
3/4"	16.2 lbs.	12,000 lbs.	2,400 lbs.

ROPE DIAMETER	120' IN A POLYBAG (NON-SPLICABLE)	150' IN A POLYBAG (NON-SPLICABLE)	600' IN A POLYBAG (NON-SPLICABLE)
1/2"	9705-45627	9705-45628	9705-45631
5/8"	-	9705-45629	9705-45632
3/4"	-	9705-45630	9705-45633



Stable Braid (Model 806)

The double braid is a low-stretch, high strength-to weight ratio, and torque-free construction. It is durable with excellent snag, abrasion, and UV resistance. Samthane coating enhances these characteristics and improves visibility.

- Low Stretch
- Excellent Abrasion Resistance
- High Strength-To-Weight Ratio
- High Abrasion Resistance
- Flexible
- UV Resistant
- Torque Free
- Easy To Handle
- Spliceable

ELASTIC ELONGATION		
10%	20%	30%
1.10%	1.70%	2.70%

After 50 cycles at % of break strength

DIAMETER (INCHES)	WEIGHT PER 100 FT (POUNDS)	AVERAGE STRENGTH (UNSPLICED)	WORKING LOAD (UNSPLICED)
1/2"	8.2 lbs.	10,400 lbs.	2,100 lbs.
5/8"	14.0 lbs.	16,300 lbs.	3,300 lbs.
3/4"	18.0 lbs.	20,400 lbs.	4,100 lbs.

	1/2" DIAMETER	5/8" DIAMETER	3/4" DIAMETER
150' Length	9705-45634	9705-45635	9705-45636
600' Length	9705-45637	9705-45638	9705-45639



Samson
THE STRONGEST NAME IN ROPE





HIGH PERFORMANCE, LIGHT WEIGHT, LESS BULK 24-STRAND CLIMBING ROPE

TACHYON



CORE: Polyamide COVER: Polyester

In arborist circles, Tachyon has quickly become the most popular of 24-strand ropes. Thanks to its unparalleled feel and its exceptional performance, it is ideal for use with the latest mechanical systems. Its firm and yet flexible design featuring a polyester cover significantly improves friction hitch performance without "bagginess". The inner core keeps the diameter constant, even under load, for improved grip and less hand fatigue.

- Functions perfectly in combination with standard hardware designed for use with 11 mm ropes
- 11.5 mm diameter for improved grip and reduced hand fatigue
- Low stretch at low loads for less bounce while climbing
- High stretch at high loads to minimize impact in the event of a fall
- Consistent diameter while climbing ensures improved grip
- Easy to splice

Length	Diameter	Color	Weight (lbs/100')	Min. Break Strength (lbs)	Hank	1" Eye
120'					9705-46341	9705-46342
150'	7/16"	Green/Blue*	6.3	5900	9705-46343	9705-46344
200'					9705-46345	9705-46346
600'					9705-46347	-

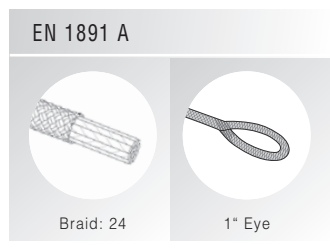

* Additional colors (shown above) are available. Please call 1-877-GO ALTEC (1-877-462-5832) to order.

1/2 INCH - THE INDUSTRY STANDARD 16-STRAND CLIMBING ROPE

BRAIDED SAFETY BLUE

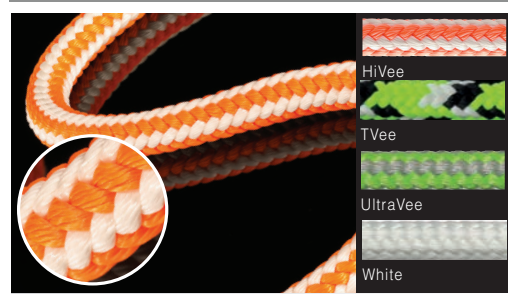

CORE: Polyamide COVER: Polyester

Braided Safety Blue trendsetter among 16-strand climbing ropes. It combines features that ensure unparalleled safety, ergonomics, and durability. The blue core of Braided Safety Blue is exposed when the rope suffers deep damage or has worn down to a certain point so that it should be discarded. As a full 12.7 mm rope, Braided Safety Blue goes easy on your hands. This allows you to work longer and avoid injury. Where durability is concerned, Braided Safety Blue's design and detailed workmanship are unrivaled. The additional step of plying the yarns in the strands results in a firmer, rounder, and more durable strand. Other 16-strand ropes skip this step, which makes them more susceptible to abrasion and thus also shortens their life spans.

- Proprietary "blue" safety core
- Plied strand yarns for improved abrasion resistance
- Coating with a protective finish improves durability and grip
- Easy to splice

Length	Diameter	Color	Weight (lbs/100')	Min. Break Strength (lbs)	Hank	1" Eye
120'					9705-46348	9705-46349
150'	1/2"	Hi-Vee (Orange/White)*	6.3	5800	9705-46350	9705-46351
200'					9705-46352	9705-46353
600'					9705-46354	

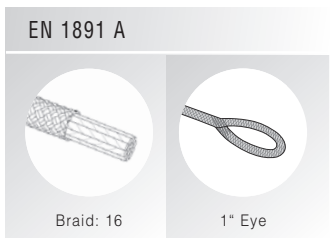

* Additional colors (shown above) are available. Please call 1-877-GO ALTEC (1-877-462-5832) to order.

16-STRAND

16-Strand Ropes: What the majority of climbers use. These ropes are 1/2" in diameter and are typically a kernmantle construction. The result is a rope that stays firm and round and holds up well in abrasion environments. This rope is also easy to splice.

24-STRAND

24-Strand ropes: These ropes were designed in response to demand from climbers who wanted products that work with commercially available mechanical devices popular in rope rescue and mountaineering. Typically smaller diameter ropes (11mm - 11.5mm) and much lighter than traditional climbing ropes.



ARBORIST EQUIPMENT

USA: 1-877-GO ALTEC
(1-877-462-5832)

www.alteccconnect.com



TOGETHER IN MOTION



NEW ENGLAND ROPES

TOGETHER IN MOTION

DURABILITY - PERFORMANCE YOU CAN COUNT ON RIGGING ROPES

SIRIUS BULL ROPE

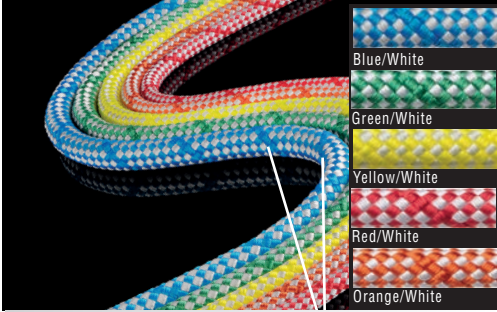

CORE: Polyester COVER: Polyester

Machinery Directive 2006/42/EC

For years now, Sirius Bull Rope has been a must-have for arborists. This is why we expanded and upgraded our Bull Rope line. What is new are the transverse stripes in the cover pattern which indicate when the rope is overloaded. In addition, our Bull Rope series now also includes 18 mm and 20 mm models. The various diameter versions can now be distinguished easily via differently colored tracer threads.

Sirius Bull Rope continues to be a highly abrasion resistant and easy to knot rope offering unmatched value for money.

Features reference points to identify overload

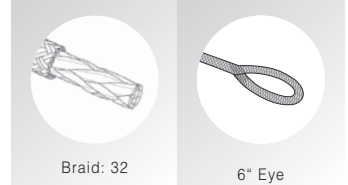

Length	Diameter	Color	Min. Break Strength (lbs)	150'	200'	150' with eye	230' with eye
8	12	White/Red	7900	9705-46355	9705-46356	9705-46357	9705-46358
10	14	White/Orange	11700	9705-46359	9705-46360	9705-46361	9705-46362
12	16	White/Yellow	14200	9705-46363	9705-46364	9705-46365	9705-46366
14	18	White/Green	17300		9705-46367	9705-46368	9705-46369
16	20	White/Blue	19800		9705-46370	9705-46371	9705-46372

* Additional colors (shown above) are available. Please call 1-877-GO ALTEC (1-877-462-5832) to order.

DURABILITY - PERFORMANCE YOU CAN COUNT ON RIGGING ROPES

STA-SET (COATED)

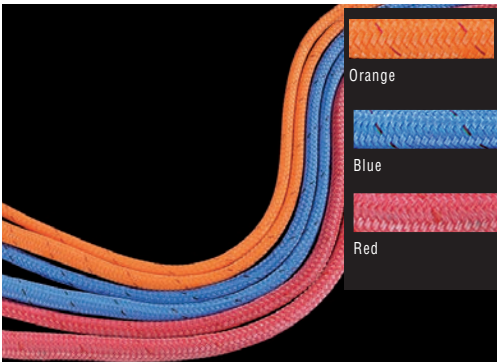

CORE: Polyester COVER: Polyester

Machinery Directive 2006/42/EC

Sta-Set is a durable premium grade double braided polyester rope. Its stronger cover featuring a high degree of twist in the yarns makes Sta-Set a flexible and highly resistant rigging rope. Its use is particularly recommended for cases where blocks are employed. Our urethane coating imparts to Sta-Set greater abrasion resistance. Sta-Set exhibits good knot strength and can be readily spliced into slings.

- Smaller diameter ropes have three yarns per strand cover
- Ropes having diameters above 15.9 mm include 2 yarns per strand
- Coated for improved abrasion resistance
- Easily spliced
- Good knot strength
- Low stretch

Diameter	Color	Min. Break Strength (lbs)	150'	200'	600'
1/2"	Red	8850	9702-00479	9705-46373	9705-46374
9/16"	Orange	9500	9705-46375	9705-46376	9705-46377
5/8"	Blue	13000	9705-46378	9705-46379	9705-46380
3/4"	Red	22000	9705-46381	9705-46382	9705-46383
7/8"	Orange	26600	9705-46384	9705-46385	9705-46386

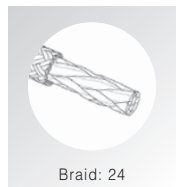

* Additional colors (shown above) are available. Please call 1-877-GO ALTEC (1-877-462-5832) to order.



TOGETHER IN MOTION



NEW ENGLAND ROPES

TOGETHER IN MOTION

SAFETY AND DURABILITY LANYARDS AND FLIPLINES

WIRE CORE FLIPLINES

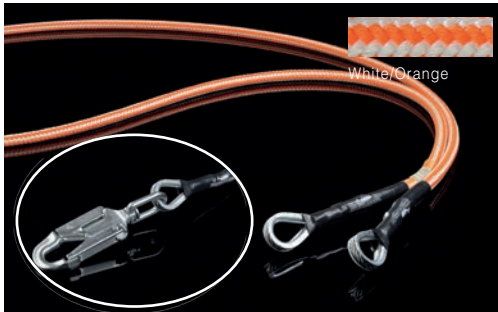

EN 358

Braid: 16

Available in 1/2" diameter, our fliplines feature a Hi-Vee cover tightly braided over wire. This diameter and construction allow using this rope product with most types of ascenders and adjusters. Each end is CE-approved.

Available as 8', 10', 12', 14', and 16' lengths

Caution: Not for use near electrical conductors!

Features

- Eyes on both ends
- Eye on one end, carabiner and swivel carabiner on the other end
- Eye on one end, carabiner and swivel carabiner on the other end

Length	Diameter	Color	Weight (lbs/100')	Min. Break Strength (lbs)	Eye on Both Ends	Eye on One End Carabiner on the other	Eye on one end, Locking Swivel Snap on the other
8'					9705-46387	9000-42558	9705-46388
10'					9705-46389	49000-42501	9705-46390
12'	1/2"	Hi-Vee (orange/white)	7.1	5000	9705-46391	9705-46392	9705-46393
14'					9705-46394	9705-46395	9705-46396
16'					9705-46397	9705-46398	9705-46399

* Additional colors (shown above) are available. Please call 1-877-GO ALTEC (1-877-462-5832) to order.

ARBORIST EQUIPMENT

USA: 1-877-GO ALTEC
(1-877-462-5832)

www.alteccconnect.com

ROPES

Prusik Loop



- Comes in 1/2" nylon, 3 strand with a locking snap spliced into the rope for versatility and ease of operation
- Tie into a Prusik knot as a safety device on a climbing line or as an adjustment for fliplines

P/N 9000-50324 20" length

Wire Core Flipline



- Available in 1/2" Safety Blue High-Vee braided over wire
- A tight, snag-free construction and the flipline's size allow use with most ascenders/adjusters
- A unique eye termination helps alleviate pivot point stress for increased service life
- Lightweight for improved performance and easier use

- Comes with eye in one end and locking snap in the other

P/N 9000-42558 8' long

P/N 9000-42501 10' long

3-Strand Bull Rope

- This popular 3-strand bull rope is a composite rope made of polyester yarns wrapped around a core of polyolefin in each strand
- Spun polyester is added to the surface for better grip and chafe protection
- Multiline II can be identified by the two orange markers on the surface of one strand
- This rope can also be used as a safety and rescue rope



P/N	Diameter	Length	Tensile Strength
9000-07150	5/8"	150'	8,200 lbs.
9000-07600	5/8"	600'	8,200 lbs.
9000-73500	3/4"	150'	10,500 lbs.
9000-73600	3/4"	600'	10,500 lbs.

Rope Insulator



- This dielectrically tested insulator attaches between the pruner head and rope helping to prevent the rope from conducting electricity if contacted above the insulator

- Available in 8 1/2" and 12" lengths

P/N 9000-12442 8.5" length

P/N 9000-12443 12" length

Flipline (Beranek Lanyard)



- Available in 1/2" Braided Safety Blue High-Vee
- This rope can be used as an adjustable flipline with either P/N 9000-50324 or a mechanical adjustment device
- The length can be adjusted by simply pulling on a "tail"
- This flipline has a backsplice on one end and a locking snap on the other

P/N 9000-06930

1/2" diameter

8' long

Bull Rope-Industrial Polyester Double Braid

- This polyester double braid bull rope offers non-hocking, torque-free construction
- This rope is the strongest low stretch rope available for bull rope applications
- Recommended especially for applications where lowering devices are being used
- High strength allows increased safety factors and/or use of smaller diameter lines



P/N	Diameter	Length	Tensile Strength
9000-22435	5/8"	150'	14,400 lbs.
9000-22436	5/8"	600'	14,400 lbs.
9000-22415	3/4"	150'	20,000 lbs.
9000-22416	3/4"	600'	20,000 lbs.

Climbing Rope-Braided Safety Blue



- This rope offers a tightly plied, polyester 16-strand cover, providing a smooth, snag-free surface
- Polyolefin yarns in the core of each cover strand reduce weight and improve handling
- This rope greatly exceeds industry specifications of 5,400 lbs.
- Twisted parallel blue yarns, in a blue core, allow the rope to stay firm and round while in use
- Core also acts as a warning flag if the cover is ever cut
- The tough durable cover is treated with a protective finish that minimizes abrasion and maximizes rope life



P/N	Diameter	Length	Tensile Strength
9000-03250	1/2"	120'	7,700 lbs.
9000-03150	1/2"	150'	7,700 lbs.
9000-03600	1/2"	600'	7,700 lbs.

Split Tail, eye in one end

P/N	Diameter	Length
9000-05250	1/2"	6'

Climbing Rope-Braided Safety Blue High-Vee



- Offers the same performance qualities and construction as the Braided Safety Blue, but with a highly visible orange and white work cover pattern
- Greatly exceeds industry specifications of 5,400 lbs.
- High-Vee stands out in the workplace and can be designated as a critical life safety line



P/N	Diameter	Length	Tensile Strength
9000-32520	1/2"	120'	7,000 lbs.
9000-32550	1/2"	150'	7,000 lbs.
9000-32610	1/2"	600'	7,000 lbs.

Spliced Eye

P/N	Diameter	Length	Tensile Strength
9000-52502	1/2"	120'	7,000 lbs.
9000-52505	1/2"	150'	7,000 lbs.

Split Tail, eye in one end

P/N	Diameter	Length
9000-52506	1/2"	6'

GAS-POWERED SAW ACCESSORIES

Tearaway Chainsaw Lanyard



- Features a built-in bungee, designed to give users added safety and convenience
 - Constructed with a tear-away safety pack that activates when 200 lbs. of force is applied
 - Lanyard measures up to 50" when fully extended and contracts to 32" when relaxed
 - The saw, if dropped, will fall below the user's feet without falling to the ground
 - A 1 3/4" steel ring suspends the chain saw when not in use
- P/N 9000-25412

Chain Saw Scabbard



- This chain saw scabbard prevents damage to the chain and fastens using a handy strap and buckle
 - For use with bar lengths from 16" to 20"
 - Available in high-quality top grain leather or rubberized belting material
 - 18 1/4" overall length
 - 17 3/4" pocket depth
- P/N 9000-16022 Leather
P/N 9000-16021 Belting

POLE SAWS

Pole Saws

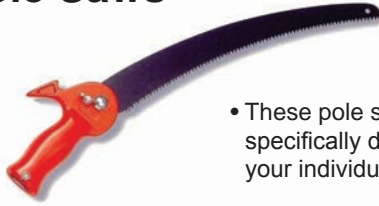

- These pole saws are specifically designed to fit your individual needs

- P/N 9000-01247 Pole Saw Casting with 16" Blade
- P/N 9000-01248 Adapter, For use with Pole Saw
- P/N 9000-01249 Pole Saw with Adapter, Leather Scabbard
- P/N 9000-12430 Heavy Duty Pole Saw Casting
- P/N 9000-12433 Heavy Duty Pole Saw Casting w/Adapter
- P/N 9000-12434 Pole Saw Casting w/Adapter & Leather Scabbard

Saw Head Sections



- These saw head sections work with these high-quality pole saws to offer you easy accessibility to hard to reach areas
- Pole saw head on top and male ferrule on bottom

Size	Foam Core Series	Hollow Series
3' long	P/N 9000-12435	P/N 9000-12438
6' long	P/N 9000-12436	P/N 9000-12439
8' long	P/N 9000-12437	P/N 9000-12440

Saw Blades



- Specifically designed to work with today's professional
- Utilizing pruner and pole saw adapter systems, these high quality blades will work with either the foam core or hollow series poles, and offer superior cutting and easy accessibility to those hard to reach areas

- P/N 9000-01141 Fits P/N 9000-12435 & P/N 9000-12438 Saw Head Sections
- P/N 9000-01150 Fits P/N 9000-60011 Pruner
- P/N 9000-01222 Fits P/N 9000-01247 & P/N 9000-60011 Pruner, P/N 9000-12438 & P/N 9000-12435 Saw Head Sections
- P/N 9000-01224 Fits P/N 9000-01247 Pole Saw Casting with 16" Blade
- P/N 9000-01245 Universal Saw Blade Adapter Casting with Bolt
- P/N 9000-01246 Universal Tool Adapter

EQUIPMENT STORAGE BAGS

Heavy Duty Waterproof Equipment Bag



- This heavy duty waterproof equipment bag with a reinforced bottom is a popular choice among arborists
- A large inside pocket accommodates miscellaneous parts
- Measures 24" long by 11" wide
- The pocket measures 13" long by 8"

P/N 9000-45331

Pole Storage Bag



- This heavy-duty vinyl pole bag provides a convenient way to carry pole sections while guarding them from damage
- Bag has four 6' pole pockets, carrying straps, and an outside pruner head pocket sized for any pruner head

P/N 9000-12441

Water Resistant Rope Bag



- Large handles make it easy to carry; small pockets on the outside can be used to store carabiners and miscellaneous hardware
- Extra stiff sides prevent the bag from collapsing while feeding rope into it
- A heavy duty drawstring closure on the top keeps rope in and the weather out
- Ideal for storing throwline, throw bags, and other equipment
- Stores 150' of 1/2" rope
- Bag has dimensions of 12" diameter and 16" height.

P/N 9000-04569

Rigid Vinyl Tool Bucket - Round

- 14 1/2" tall x 11 3/4" diameter round tool bucket
- Features brass grommets and rope with a brass swivel snap
- Molded rubber runners on bottom

P/N 9700-98046



PRUNER TOOLS & ACCESSORIES

Pruners



- Simplify the process of ordering pruners by getting one of these quick and easy pruner packages or pruner kits
- These packages and kits come in various assortments of pruners and accessories to make ordering easier

Pruner Packages

- P/N 9000-10100 9000-60011 Pruner, 9000-61100 Adapter, Saw Blade, Rope and Canvas Scabbard
- P/N 9000-10101 9000-60012 Pruner, 9000-61200 Adapter and Rope

Pruner Kits

- P/N 9000-11110 (3) 6' Hollow Poles, 9000-60011 Pruner, 9000-61100 Adapter, 20' Rope
- P/N 9000-11120 (3) 6' Hollow Poles, 9000-60012 Pruner, 9000-61200 Adapter, 20' Rope
- P/N 9000-11140 (3) 6' Hollow Poles, 9000-14000 Pruner, 9000-61400 Adapter, 20' Rope
- P/N 9000-01110 (3) 6' Foam Core Poles, 9000-60011 Pruner, 9000-61100 Adapter, 20' Rope
- P/N 9000-01120 (3) 6' Foam Core Poles, 9000-60012 Pruner, 9000-61200 Adapter, 20' Rope
- P/N 9000-01140 (3) 6' Foam Core Poles, 9000-14000 Pruner, 9000-61400 Adapter, 20' Rope

Pruner Adapter



- Adapters make it possible for one pole to do all jobs
- May be used with other manufacturers' pruner heads and pole saws with hollow and foam core poles
- Complete pruner head and adapter may be quickly and easily removed at any time

	<u>Diameter</u>	<u>For Pole:</u>
P/N 9000-61100	1"	P/N 9000-60011
P/N 9000-61200	1 1/2"	P/N 9000-60012
P/N 9000-61400	1 1/4"	P/N 9000-14000

Heavy Duty Side-Cut Pruners



- This heavy duty side-cut pruner features forged steel working components, which deliver extra cutting power to the blade
- This pruner is also available with an added swivel pulley

Base Pruner

P/N 9000-14000 1 1/4" diameter

Base Pruner w/Swivel Pulley

P/N 9000-14001 1 1/4" diameter

Foam Core Pruner Poles



- 1 1/4" diameter
- It has increased flexural strength and a moisture barrier for high dielectric protection
- Has aircraft grade aluminum ferrules with an exterior leaf spring locking button, giving a secure and positive connection when attaching pole extensions and accessories

Extension Poles: Male and Female Ferrules

P/N 9000-30501 3' long

P/N 9000-60501 6' long

Base Poles: Female Ferrule on Top, End Cap on Bottom

P/N 9000-60506 6' long

P/N 9000-60508 8' long

Head Poles

P/N 9000-60503 3' long

P/N 9000-60560 6' long

Hollow Pruner Poles



- This alternative to the foam core pole is a very popular fiberglass pole
- The hollow pole uses the same aircraft grade aluminum ferrules and exterior leaf spring as the foam core pole

Extension Poles: Male and Female Ferrules

P/N 9000-60530 3' long

P/N 9000-99413 6' long

Base Poles: Female Ferrule on Top, End Cap on Bottom

P/N 9000-60006 6' long

P/N 9000-60008 8' long

Head Poles

P/N 9000-60003 3' long

P/N 9000-60002 6' long

Pruner Cover



- Fits over the potentially hazardous blade of 1" pole pruners
 - Available in either high quality top grain leather or rubberized belting material
- P/N 9000-06017 Leather

Center Cut Pruners



- The standard with telecommunications and cable television industries for trimming around aerial lines or drops
- With its unique adapter system, it is possible to use a variety of pruner heads with either hollow or foam core poles

P/N 9000-60011 1" diameter

P/N 9000-60012 1 1/2" diameter

ARBORIST EQUIPMENT

USA: 1-877-GO ALTEC
(1-877-462-5832)

www.alteccconnect.com

LOGGING TOOLS

Osh Kosh Lug Hooks



- Made exclusively for carrying poles by hand
- Handles are made of sturdy hard maple
- Hooks are made from high-carbon steel and attached to the handle with a malleable iron swivel to facilitate easy operation

- P/N 9000-00295 295 Lug Hook, 2 1/2" x 4'
 P/N 9000-00593 593 Replacement Handle, 2 1/2" x 4'
 P/N 9000-00296 296 Lug Hook, 2 1/2" x 4'-6"
 P/N 9000-00594 594 Replacement Handle, 2 1/2" x 4'-6"
 P/N 9000-00297 297 Lug Hook, 2 1/2" x 5'
 P/N 9000-00595 595 Replacement Handle, 2 1/2" x 5'
 P/N 9000-00298 298 Lug Hook, 3" x 5'
 P/N 9000-00963 963 Replacement Handle, 3" x 5'
 P/N 9000-00299 299 Lug Hook, 3" x 6'
 P/N 9000-00964 964 Replacement Handle, 3" x 6'

Hisco Cant Hooks



- These cant hooks are made with hardwood handles and high carbon steel hooks which are heat treated and tested
- The hardwood handles are made of selected air-seasoned hard wood
- Designed and constructed for balance and easy handling and finished with a hard transparent lacquer
- The unique hook-stop prevents the hook from falling back and damaging

the wooden handle

- Cant Hooks are for turning, rolling, and lifting logs or poles
- Each is equipped with a 1 1/4" solid fiberglass handle and a sharpened pencil point
- A flat point hook can be ordered, upon request
- Available in three sizes 8", 10", and 12"
- Available with 4' or 6' fiberglass handles

- P/N 9000-99387 8" hook, 4'
 P/N 9000-99388 8" hook, 6'
 P/N 9000-99383 10" hook, 4'
 P/N 9000-99384 10" hook, 6'
 P/N 9000-99385 12" hook, 4'
 P/N 9000-99386 12" hook, 6'
 P/N 9000-99377 Handle assembly, no hook, 4'
 P/N 9000-99378 Handle assembly, no hook, 6'
 P/N 9000-01999 2 1/2" x 4'
 P/N 9702-12271 Replacement Handle, 2 1/2" x 4'
 P/N 9000-02000 2 1/2" x 4'-6"
 P/N 9000-00576 Replacement Handle, 2 1/2" x 4'-6"
 P/N 9000-02010 2 1/2" x 5'
 P/N 9000-00577 Replacement Handle, 2 1/2" x 5'
 P/N 9000-00480 Replacement Hook, 1" x 1/2"



Osh Kosh Peavies



- Designed and constructed for balance and easy handling
- Handles are made of hardwood and the hooks and pikes are constructed of high-carbon steel
- Unique hook stop prevent the hook from falling back and damaging the wooden handle
- Peavies are intended to have only human force applied during their use
- Adding an extension or mechanical force on the handle can result in tool damage and serious injury to the user

- P/N 9000-01370 137 2 1/2" x 4'
 P/N 9000-00575 575T Replacement Handle, 2 1/2" x 4'
 P/N 9000-01380 138 2 1/2" x 4' - 6"
 P/N 9000-00576 576T Replacement Handle, 2 1/2" x 4'6"
 P/N 9000-01390 139 2 1/2" x 5'
 P/N 9000-00577 577T Replacement Handle, 2 1/2" x 5'
 P/N 9000-00480 480 Replacement Hook, 1" x 1/2"

Osh Kosh Skidding Tongs



- Skidding tongs are intended for pulling or skidding material and are not load rated
- Not designed for overhead lifting
- These skidding tongs are made from round, high-carbon steel bar stock, which is hammer forged and heat treated for consistent strength
- The tong sides are flattened evenly for a larger pivot bearing surface; this allows the pivot to be shorter

- and ensures the hooks stay in proper alignment
- Each tong unit is heat treated and 100% hardness tested to assure high quality
- The tongs are made in either "ring only" or "swivel hook and ring" style

- P/N 9000-03841 384A Tong w/ring, 1" x 16"
 P/N 9000-03842 384B Tong w/ring, 1" x 21"
 P/N 9000-00384 384 Tong w/ring, 1" x 24"
 P/N 9000-00385 385 Tong w/ring, 1 1/8" x 32"
 P/N 9000-00386 386 Tong w/ring, 1 1/4" x 36"

Tool Organizer Boards



- Stores any standard hydraulic "stick saw"
- Keeps tool out of the platform when working around electrical lines
- Stores tools while vehicle is in transit
- ABS plastic withstands weather conditions; will not dull tool blades

P/N 8095-00204 Greenlee Style

Boom Mounted Circular Saw Holder



- Provides a safe and out of bucket storage location for all standard hydraulic circular saws
- Made of high impact plastic, the holder unit can be strapped to square or round booms and is adjustable to any convenient position

P/N 8780-10489

Boom Mounted Hot Stick Holder



- Holds four hot sticks 1 1/4" - 2" dia.
- Ratchet load binders attach to square, rectangular, round and oval booms

P/N 7054-00287

Hydraulic Pruner Holder



- Made from high impact plastic
- Stores any standard hydraulic pruner
- Mounts on both round and square booms

P/N 8130-00428

Replacement Handle Holder



- Replacement handle holder for the hydraulic boom mounted tool holders
- Rubberized liner prevents the tool handle from sliding out of the upper holder box
- Fits both square and round booms

P/N 9000-24041

Chain Saw Scabbards

- These chain saw scabbards provide a safe and convenient storage place for either a gasoline or hydraulic powered chain saw



P/N 8130-00205 Fiberglass



P/N 9703-35053 Plastic

Utility Light



- Specially designed for night work
- 200,000 candlepower halogen light produces 1 hour spot and 5 hours flood lighting
- Built in DC charger recharges in 8 hours
- Built in charger draws 12 volt DC or 120 volt AC
- Battery condition light glows green in use and turns red when power is low
- Head swivels 360°
- Constructed of weatherproof, nonconductive thermoplastic
- Also comes with a shatter guard and locking brackets to protect the light when platform is descending

P/N 9000-21222

Utility Light



- 110V Safety light allows workers to be dielectrically safe for confident use in areas with electrical contact risk
- Sealed beam bulb housing comes with a shatter guard
- Beam is diffused into a flood pattern for greater lighting capabilities
- Insulated housing is impact resistant and impervious to corrosion
- Will mount anywhere on platform rim
- Comes standard with a 72" long cord

P/N 9000-21600 Standard cord

P/N 9000-21610 Extra long cord

SAFETY EQUIPMENT

Wind Resistant Roll-Up Safety System

Wind-Resistant Roll-Up Sign



- Available in 36" or 48" sizes
- These signs feature a highly reflective surface for maximum visibility in all conditions
- Rib supports are designed for use with screw lock, channel, or pocket style sign panel holders
- Signs include Velcro® anti-kiting and storage straps

- P/N 9000-99715 36" Men Working Sign
- P/N 9000-99924 36" Worker Symbol Sign
- P/N 9000-99717 36" Flag Man Ahead Sign
- P/N 9000-99716 36" Utility Work Ahead Sign

- P/N 9000-99719 48" Changeable Right/Left Lane Sign
- P/N 9000-24432 48" Utility Work Ahead Sign
- P/N 9000-99713 48" Men Working Sign
- P/N 9000-99714 48" Flag Man Ahead Sign
- P/N 9000-99923 48" Worker Symbol Sign

Wind-Resistant Dynaflex Sign Stand



- NCHRP 350 compatibility- crash test results available
- Complies with MUTCD standards
- Features wind-relieving dual torsion spring system
- Ease of use with fast kick release system, locking legs into place when fully extended
- Displays 36" and 48" signs using ScrewLock™ attachment
- All aluminum and steel construction
- Telescoping aluminum legs with two position height adjustment and anti-skid foot pads
- Full extension length: 51" (1295 mm) each leg
- Open footprint: 92" x 57-1/2" (2337 mm X 1461 mm)
- Wind-relieving, dual torsion spring system - withstands winds up to 65 mph
- Minimum height from the ground to bottom of panel: 12" (305mm)

P/N 9702-84417 Fits Wind-Resistant Roll-Up Signs

Dynaflex Sign Stand



- NCHRP-350 approved
- Complies with MUTCD standards
- Dual torsion springs
- Hold 36" and 48" signs in a variety of materials and configurations
- All aluminum and steel construction
- Features telescoping aluminum legs with two position height adjustment and anti-skid foot pads
- Easy to use with kick release system

for legs and quick locking sign holders

• Minimum height from ground to bottom of panel: 12"

P/N 9000-24427 Fits Fold and Roll Signs

Aluminum Stop/Slow Paddle



- Available in either 18" or 24"
- Complies with MUTCD standards
- Aluminum octagon paddle features high intensity reflective sheeting
- Includes 12" plastic staff
- Optional: add a 62" two-piece plastic staff for 5' height requirements

P/N 9700-20729 18"

P/N 9700-20722 24"

P/N 9700-20644 5' PVC Staff

Safety Cones



- Rugged, brightly colored safety cones
- Designed for many years of outside use
- Cones are constructed of day-glow red/orange PVC with two reflective collars
- 18", 28", and 36" tall cones available

P/N 9000-00215 18" Cone

P/N 9000-00216 28" Cone

P/N 9000-30042 36" Cone

Twin Flex Dual Spring Sign Stand



- Complies with MUTCD standards
- Features two vertical coil springs
- Displays 36" and 48" reflective signs
- All aluminum and steel construction
- Features telescoping aluminum legs with two position height adjustment and anti-skid foot pads
- Quick setup and tear down with kick release system for leg deployment
- Minimum height from ground to bottom of panel: 12"

P/N 9700-20598 Twin Flex Dual Spring Sign Stand

Uniflex Single Spring Sign Stand



- NCHRP-350 approved
- Complies with MUTCD standards
- Features versatile, compact single-coil spring
- Displays 36" and 48" reflective signs using ScrewLock™ attachment
- All aluminum and steel construction
- Features telescoping aluminum legs with two position height adjustment, anti-skid foot pads
- 12" minimum height from ground to panel edge

P/N 9700-20643 Uniflex Sign Stand

CROSSBRACE ASSEMBLIES:

P/N 9000-24406 36" Crossbrace Assembly

P/N 9000-24407 48" Crossbrace Assembly

High-Vis Orange Reflective Vest



- Design conforms to the Manual of Uniform Traffic Control Devices
- The vest's bright, dayglow colors can be easily seen by oncoming street traffic
- The front and back of the vest feature 3/4" or 1 3/8" vertical reflective stripes
- Lightweight, 100% polyester mesh material
- P/N 9000-00214 (Orange w/Yellow Stripes)
- P/N 9700-21026 (Lime w/White Stripes)

TREE CARE EQUIPMENT

Echo KEVLAR® Protective Chaps



- Manufactured using DuPont™ KEVLAR® material for superior strength and durability
- Available in 36" and 40" lengths

P/N 9000-00521 103942143 36"
 P/N 9000-00522 103942144 40"

Jameson Tree Trimming Packages



- Jameson Part Number FG-6PKG1:
 6' Extension Pole with Male and Female Ferrules
 6' Base Pole with Female Ferrule and Base Cap
 Heavy Duty Pruner
 Tri-Cut Saw Blade and Pole Saw Head
- Jameson Part Number FG-6PKG2:
 6' Extension Pole with Male and Female Ferrules
 6' Base Pole with Female Ferrule and Base Cap
 Heavy Duty Pruner
 Tri-Cut Saw Blade and Pole Saw Head
 Wire and Limb Raiser
 13" Tri-Cut Hand Saw

P/N 9701-41786 FG-6PKG1 Professional Pruning Package
 P/N 9701-41789 FG-6PKG2 Complete Pruning Package

Jameson Telescoping Pole Package



- Includes:
 6-12' Double Lock® Telescoping Pole
 Heavy Duty Pruner
 Rope with Wooden Handle
 Pole Adapter
 Pole Saw Head
 13" Barracuda™ Tri-Cut Saw Blade
- High quality, lightweight fiberglass pole
- Double locks ensure poles will not collapse, offering a secure connection at any length
- Will not crimp like aluminum poles

P/N 9701-41790 TP-12PKG1

Jameson Double Lock™ Telescoping Pole



- Fiberglass pole features double locks to ensure poles will not collapse, offering a secure connection at any length

P/N 9702-12165 Jameson TP-12F

Jameson SB-5U



- Using SB-UC and UA-1 adapters, saw blade unit snaps directly onto pole's ferrule

Photo shows SB-2 16" Agressive Cut Teflon Saw blade with SB-UC universal saw blade adapter

P/N 9702-12164 Jameson SB5U

ARBORIST EQUIPMENT

USA: 1-877-GO ALTEC
(1-877-462-5832)

www.alteccconnect.com

Jameson Fiberglass Poles

B-Lite Fiberglass Poles



- Jameson's Thinnest Walled Poles
- .075" Wall Thickness x 1.25" Pole Diameter
- Lighter weight, same heavy-duty control as FG Series
- Less fatigue during extended work periods and easier handling
- Durable, high gloss enamel coating for long life, easy cleaning, and prevention of fiber bloom
- Batch tested to 100KV per foot for five minutes
- Not a "hot stick"

BL Pole	Description	6'	8'	10'	12'
Extension Pole	Female & Male Ferrules	P/N 9705-16610 BL-6	P/N 9705-16611 BL-8	P/N 9705-16612 BL-10	P/N 9705-16613 BL-12
Base Pole	Female Ferrule & Rubber Base Cap	P/N 9705-16614 BL-6F	P/N 9705-16615 BL-8F	P/N 9705-16616 BL-10F	P/N 9705-16617 BL-12F
Head Pole	Male Ferrules & Eyebolt for Pruner Rope	P/N 9705-16618 BL-6M	P/N 9705-16619 BL-8M	P/N 9705-16620 BL-10M	P/N 9705-16621 BL-12M
Top Pole	Blank End & Male Ferrule	P/N 9705-16622 BL-6BM	P/N 9705-16623 BL-8BM	P/N 9705-16624 BL-10BM	P/N 9705-16625 BL-12BM
PS-3FP Sawhead Pole	Male Ferrule & PS-3FP Sawhead	P/N 9705-16626 BL-6SFP	P/N 9705-16627 BL-8SFP	P/N 9705-16628 BL-10SFP	P/N 9705-16629 BL-12SFP

Foam Core Base Pole

- At 1-1/4" diameter, the original JE Series foam core fiberglass pole is still Jameson's highest quality pole. Its strength to weight ratio is unmatched by any pole on the market. In addition, it has increased flexural strength and a moisture barrier for high dielectric protection (the ultimate in safety), making it the right choice for line clearance
- Every JE series pole is tested to 100KV per foot for five minutes
- Jameson uses aircraft grade aluminum ferrules with an exterior leaf spring locking button, giving a secure and positive connection when attaching pole extensions and accessories
- Extension Pole: Female Ferrule and Male Ferrule
- Base Pole: Female Ferrule and Rubber End Cap
- Head Pole: Male Ferrule with Eyebolt for Pruner Rope and Male Ferrule
- Top Pole: Blank End and Male Ferrule
- Sawhead Section: Pole Saw Head and Male Ferrule
- Available with PS-3, PS-3F or PS-3FP Casting



Pole	Ferrule	3'	4'	6'	8'	10'	12'
Extension Pole	Female & Male Ferrule	P/N 9705-16630 JE-3	P/N 9705-16631 JE-4	P/N 9705-16632 JE-6	P/N 9705-16633 JE-8	P/N 9705-16634 JE-10	P/N 9705-16635 JE-12
Base Pole	Rubber Base Cap & Female Ferrule	P/N 9705-16636 JE-3F	P/N 9705-16637 JE-4F	P/N 9705-16638 JE-6F	P/N 9705-16639 JE-8F	P/N 9705-16640 JE-10F	P/N 9705-16641 JE-12F
Head Pole	Male Ferrules & Eyebolt for Pruner Rope	P/N 9705-16642 JE-3M	P/N 9705-16643 JE-4M	P/N 9705-16644 JE-6M	P/N 9705-16645 JE-8M	P/N 9705-16646 JE-10M	P/N 9705-16647 JE-12M
Top Pole	Blank End & Male Ferrule	P/N 9705-16648 JE-3BM	P/N 9705-16649 JE-4BM	P/N 9705-16650 JE-6BM	P/N 9705-16651 JE-8BM	P/N 9705-16652 JE-10BM	P/N 9705-16653 JE-12BM
PS-3 Sawhead Pole	Male Ferrule & PS-3 Sawhead	P/N 9705-16654 JE-3S	P/N 9705-16655 JE-4S	P/N 9705-16656 JE-6S	P/N 9705-16657 JE-8S	P/N 9705-16658 JE-10S	P/N 9705-16659 JE-12S
PS-3F Sawhead Pole	Male Ferrule & PS-3F Sawhead	P/N 9705-16660 JE-3SHF	P/N 9705-16661 JE-4SHF	P/N 9705-16662 JE-6SHF	P/N 9705-16663 JE-8SHF	P/N 9705-16664 JE-10SHF	P/N 9705-16665 JE-12SHF
PS-3FP Sawhead Pole	Male Ferrule & PS-3FP Sawhead	P/N 9705-16666 JE-3SFP	P/N 9705-16667 JE-4SFP	P/N 9705-16668 JE-6SFP	P/N 9705-16669 JE-8SFP	P/N 9705-16670 JE-10SFP	P/N 9705-16671 JE-12SFP



AWARD-WINNING AND READY TO WORK, with the outstanding quality and dependability Altec is known for.

We are proud to announce that the DSC6, with improved features and benefits, was a 2014 New Product Award recipient. Lightweight and easy to tow behind any vehicle, this product is ideal for a variety of applications.

SALES | SERVICE | RENTAL | FINANCING | SAFETY TRAINING | TOOLS & ACCESSORIES

 **Altec.**

Altec.com
800.958.2555
sales@altec.com



Altec Tree Care:

Engineered to work hard.

And like it.

FACTORY DIRECT AND READY TO WORK, with the outstanding quality and dependability Altec is known for.

FOR PRICING AND AVAILABILITY, CALL
800.958.2555
TO SPEAK WITH AN ALTEC REPRESENTATIVE
or visit us online at altec.com/stock

 **Altec.**

Altec.com
800.958.2555
sales@altec.com



**TURNING
POSSIBILITIES
INTO
REALITY**



888.408.8148

FINANCE@ALTEC.COM

WHY USE ALTEC CAPITAL?

Enjoy the convenience of using a single company to provide both solutions for your equipment and financing needs - a "one-stop" shop. Altec Capital, and its parent, Altec Inc's sole focus is creating value for our customers through personalized services and solutions. With business consultants located throughout the United States, Altec Capital can mobilize our resources to accelerate results and leverage our alliances and partnerships to help deliver innovative solutions to our customers. Contact us today to learn more.



THE EQUIPMENT YOU NEED WHEN YOU NEED IT



Global
Global Rental Co., Inc.

800.445.6295

GLOBALRENTAL@ALTEC.COM

PROVIDING THE MOST COMPLETE LINE OF UTILITY EQUIPMENT FOR RENT OR PURCHASE.

Providing the most comprehensive line of truck mounted rental equipment for the municipal, tree care, contractor, telecommunications and electric utility industries, short and long term rentals with flexible terms and premium quality, late model equipment, all with purchase options. Global's fleet is the newest in the industry featuring the latest design elements to ensure your crews are working safely and productively. And Global's customer service network is unsurpassed, offering complete coverage in the US and Canada to keep your equipment up and running on the job site.

**BUY
DIRECTLY
FROM THE
SOURCE**



**Altec
NUECO**

**866.617.1569
SALES@NUECO.COM**

THE ONLY SUPPLIER OF ALTEC CERTIFIED PRE-OWNED TRUCKS

Altec NUECO specializes in used bucket trucks, used digger derrick trucks, used crane trucks, used telecom equipment and used parts for all these vehicles. We are the sole supplier of Certified Used Altec Equipment, and offer a multitude of other certified equipment brands, including: Aerial Lift of CT, Holan, LiftAll, MTI, Pitman, ReachAll and Teco. We are also the exclusive supplier of parts necessary to maintain this equipment. Altec NUECO has 29 Service Centers located across the United States and Canada as well as multiple remote sales locations and deal partnership facilities to better serve your needs. Contact us today!

APPENDIX A FITTINGS & ADAPTERS

USA: 1-877-GO ALTEC
(1-877-462-5832)

www.alteconnect.com

ALTEC	MFR	SUPPLIER P/N	DESCRIPTION	SWIVEL FITTINGS (MALE/FEMALE)	STRAIGHT FITTINGS (MALE/FEMALE)	HOSES
9000-42184	GREENLEE	49340	CRIMPING TOOL LPK1230	(2) 274-01155	(2) 274-01852	(1) 8' 271-29444 or (1) 10' 271-29457
9000-10604	GREENLEE	10604	CRIMPING TOOL RK6040	(1) 9000-41941	N/A	N/A
7010-69155	GREENLEE	43180	CIRCULAR SAW	(1) 274-01154 and (1) 274-01155	(1) 274-01851 and (1) 274-01852	(1) 8' 271-29444 or (1) 10' 271-29457
9000-42909	GREENLEE	42909	LONG REACH PRUNER 42909	(1) 274-01154 and (1) 274-01155	(1) 274-01851 and (1) 274-01852	(1) 8' 271-29444 or (1) 10' 271-29457
7010-69018	GREENLEE	43178	LONG REACH CHAIN SAW	(1) 274-01154 and (1) 274-01155	(1) 274-01851 and (1) 274-01852	(1) 8' 271-29444 or (1) 10' 271-29457
9000-38568	GREENLEE	38568	POLE SAW	(1) 274-01154 and (1) 274-01155	(1) 274-01851 and (1) 274-01852	(1) 8' 271-29444 or (1) 10' 271-29457
7010-69149	GREENLEE	48520	LONG REACH HYDRAULIC PRUNER (48520)	(1) 274-01154 and (1) 274-01155	(1) 274-01851 and (1) 274-01852	(1) 8' 271-29444 or (1) 10' 271-29457
9000-49566	GREENLEE	49566	HYDRAULIC STANDARD CHAIN SAW	(1) 274-01154 and (1) 274-01155	(1) 274-01851 and (1) 274-01852	(1) 8' 271-29444 or (1) 10' 271-29457
9000-49565	GREENLEE	49565	PISTOL-GRIP	(1) 274-01154 and (1) 274-01155	(1) 274-01851 and (1) 274-01852	(1) 8' 271-29444 or (1) 10' 271-29457
9000-07815	STANLEY	ID07815	ID07 IMPACT WRENCH	(2) 274-01155	(2) 274-01852	(1) 8' 271-29444 or (1) 10' 271-29457
8126-04810	STANLEY	ID04810	IMPACT DRILL ID04810	(2) 274-01155	(2) 274-01852	(1) 8' 271-29444 or (1) 10' 271-29457
9000-20025	STANLEY	DL07550	IMPACT WRENCH DL07550	(2) 274-01155	(2) 274-01852	(1) 8' 271-29444 or (1) 10' 271-29457
360-30013	STANLEY	TA54603	HYDRAULIC TAMPER	(2) 274-01155	(2) 274-01852	(1) 8' 271-29444 or (1) 10' 271-29457
9700-17137	STANLEY	TA54603A	HYDRAULIC TAMPER		(2) 274-01852	(1) 8' 271-29444 or (1) 10' 271-29457
8095-00549	STANLEY	CT04016N	HYDRAULIC CRIMPER	(2) 274-01155	(2) 274-01852	(1) 8' 271-29444 or (1) 10' 271-29457
9000-00448	STANLEY	CT06	HYDRAULIC CRIMPER	(2) 274-01155	(2) 274-01852	(1) 8' 271-29444 or (1) 10' 271-29457
90009-9427	STANLEY	GD50132RF	HYDRAULIC DRIVER	N/A	N/A	N/A
8126-37110	STANLEY	BR-37110	PAVING BREAKER	N/A	N/A	N/A
8126-45130	STANLEY	BR45130	PAVING BREAKER	N/A	N/A	N/A
8126-21511	STANLEY	SM2151101	SUBMERSIBLE PUMP	N/A	N/A	N/A
8126-05610	STANLEY	CS05610	CHAIN SAW	(2) 274-01155	(2) 274-01852	(1) 8' 271-29444 or (1) 10' 271-29457
360-00007	STANLEY	CR27891	CIRCULAR SAW	(2) 274-01155	(2) 274-01852	(1) 8' 271-29444 or (1) 10' 271-29457
9700-84092	STANLEY	CS28811	POLE SAW	(2) 274-01155	(2) 274-01852	(1) 8' 271-29444 or (1) 10' 271-29457
3600-0014	STANLEY	PR41131	84" POLE PRUNER	(2) 274-01155	(2) 274-01852	(1) 8' 271-29444 or (1) 10' 271-29457
9702-03368	BURNDY	HIW716ENF	ENFORCER IMPACT WRENCH	(2) 274-01154	(2) 274-01851	(1) 8' 271-29444 or (1) 10' 271-29457

ALTEC	QUICK DISCONNECTS	HOSE KITS - FITTINGS AND QD'S ALREADY ASSEMBLED	SEAL KITS	PORT SIZES	NOTES
9000-42184	356-20132	(1) 8' 9000-12247 or (1) 10' 9000-12248		Both Sides: 3/4-16 SAE O-Ring	
9000-10604	N/A			3/8" High Pressure Female QD on Tool	
7010-69155	356-20132	N/A		Pressure Port: 9/16-18 SAE O-Ring Return Port: 3/4-16 SAE O-Ring	
9000-42909	356-20132	N/A		Pressure Port: 9/16-18 SAE O-Ring Return Port: 3/4-16 SAE O-Ring	
7010-69018	356-20132	N/A		Pressure Port: 9/16-18 SAE O-Ring Return Port: 3/4-16 SAE O-Ring	
9000-38568	356-20132	(1) 8' 9000-12247 or (1) 10' 9000-12248		Pressure Port: 9/16-18 SAE O-Ring Return Port: 3/4-16 SAE O-Ring	
7010-69149	356-20132	(1) 8' 9000-12247 or (1) 10' 9000-12248		Pressure Port: 9/16-18 SAE O-Ring Return Port: 3/4-16 SAE O-Ring	
9000-49566	356-20132	(1) 8' 9000-12247 or (1) 10' 9000-12248		Pressure Port: 9/16-18 SAE O-Ring Return Port: 3/4-16 SAE O-Ring	
9000-49565	356-20132	(1) 8' 9000-12247 or (1) 10' 9000-12248		Pressure Port: 9/16-18 SAE O-Ring Return Port: 3/4-16 SAE O-Ring	
9000-07815	356-20132	(1) 8' 9000-12247 or (1) 10' 9000-12248		Both Sides: 3/4-16 SAE O-Ring	
8126-04810	356-20132	(1) 8' 9000-12247 or (1) 10' 9000-12248		Both Sides: 3/4-16 SAE O-Ring	
9000-20025	356-20132	(1) 8' 9000-12247 or (1) 10' 9000-12248		Both Sides: 3/4-16 SAE O-Ring	
360-30013	356-20132	(1) 8' 9000-12247 or (1) 10' 9000-12248		Both Sides: 3/4-16 SAE O-Ring	
9700-17137	356-20132				
8095-00549	356-20132	(1) 8' 9000-12247 or (1) 10' 9000-12248		Both Sides: 3/4-16 SAE O-Ring	
9000-00448	356-20132	(1) 8' 9000-12247 or (1) 10' 9000-12248		Both Sides: 3/4-16 SAE O-Ring	
9000-99427	356-20132	N/A			
8126-37110	356-20132	N/A			
8126-45130	356-20132	N/A			
8126-21511	356-20132	N/A			
8126-05610	356-20132	(1) 8' 9000-12247 or (1) 10' 9000-12248		Both Sides: 3/4-16 SAE O-Ring	
360-00007	356-20132	(1) 8' 9000-12247 or (1) 10' 9000-12248		Both Sides: 3/4-16 SAE O-Ring	
9700-84092	356-20132	(1) 8' 9000-12247 or (1) 10' 9000-12248		Both Sides: 3/4-16 SAE O-Ring	
360-00014	356-20132	(1) 8' 9000-12247 or (1) 10' 9000-12248		Both Sides: 3/4-16 SAE O-Ring	
9702-03368	356-20132	(1) 8' 9000-12247 or (1) 10' 9000-12248		Both Sides: 3/4-16 SAE O-Ring	

APPENDIX A FITTINGS & ADAPTERS

USA: 1-877-GO ALTEC
(1-877-462-5832)

www.alteconnect.com

ALTEC	MFR	SUPPLIER P/N	DESCRIPTION	SWIVEL FITTINGS (MALE/FEMALE)	STRAIGHT FITTINGS (MALE/FEMALE)	HOSES
7010-69023	GREENLEE	12682	IMPACT WRENCH H8508-1	(2) 274-01155	(2) 274-01852	(1) 8' 271-29444 or (1) 10' 271-29457
9000-42268	GREENLEE	2268	IMPACT WRENCH	(2) 274-01155	(2) 274-01852	(1) 8' 271-29444 or (1) 10' 271-29457
9700-42309	GREENLEE	42309	HYDRAULIC DRILL HID6506	(2) 274-01155	(2) 274-01852	(1) 8' 271-29444 or (1) 10' 271-29457
9000-42260	GREENLEE	42260	HYDRAULIC DRILL H6400C	(1) 274-01154 and (1) 274-01155	(1) 274-01851 and (1) 274-01852	(1) 8' 271-29444 or (1) 10' 271-29457
8930-00400	GREENLEE	42198	POLE TAMPER H4802	(1) 274-01154 and (1) 274-01155	(1) 274-01851 and (1) 274-01852	(1) 8' 271-29444 or (1) 10' 271-29457
7010-69148	GREENLEE	42199	POLE TAMPER H4802-1	(1) 274-01154 and (1) 274-01155	(1) 274-01851 and (1) 274-01852	(1) 8' 271-29444 or (1) 10' 271-29457
9000-42200	GREENLEE	42201	POLE TAMPER	(1) 274-01154 and (1) 274-01155	(1) 274-01851 and (1) 274-01852	(1) 8' 271-29444 or (1) 10' 271-29457
9000-49345	GREENLEE	49345	CRIMPING TOOL LPK1240	(2) 274-01155	(2) 274-01852	(1) 8' 271-29444 or (1) 10' 271-29457
7010-69084	GREENLEE	42200	TAMPER	(1) 274-01154 and (1) 274-01155	(1) 274-01851 and (1) 274-01852	(1) 8' 271-29444 or (1) 10' 271-29457
9000-49537	GREENLEE	45937	PAVING BREAKER HPB25	N/A	N/A	N/A
9000-49538	GREENLEE	45938	PAVING BREAKER HPB35	N/A	N/A	N/A
9000-02197	GREENLEE	2197	PAVING BREAKER 45 LB.	N/A	N/A	N/A
9000-00944	GREENLEE	11104	ROCK DRILL HRD44	N/A	N/A	N/A
9000-11183	GREENLEE	11183	SIGN POST DRIVER HPD SERIES 11183	N/A	N/A	N/A
9000-42237	GREENLEE	42237	SIGN POST DRIVER 42237	(1) 274-01154 and (1) 274-01155	(1) 274-01851 and (1) 274-01852	(1) 8' 271-29444 or (1) 10' 271-29457
9000-11192	GREENLEE	11192	GROUND ROD DRIVER HRD-58	N/A	(1) 274-01851 and (1) 274-01852	(1) 8' 271-29444 or (1) 10' 271-29457
7010-69005	GREENLEE	42239	POLE PULLER H4910A	N/A	(2) 274-01852	(1) 8' 271-29444 or (1) 10' 271-29457
9000-99682	GREENLEE	42948	PVA HYDRAULIC VALVE - SINGLE ACTING	N/A	N/A	9000-41795 or 9700-14174 High Pressure
9000-42950	GREENLEE	PVA0022	4-WAY HYDRAULIC VALVE - DOUBLE ACTING	N/A	N/A	9000-30694 or 9000-13857 High Pressure
9000-49830	GREENLEE	49830	DYNAPRESS HYDRAULIC INTENSIFIER HB10	N/A	N/A	N/A
9701-02585	GREENLEE	79550	FLOW CONTROL VALVE HFC30			

ALTEC	QUICK DISCONNECTS	HOSE KITS - FITTINGS AND QD'S ALREADY ASSEMBLED	SEAL KITS	PORT SIZES	NOTES
7010-69023	(1) 356-20132	(1) 8' 9000-12247 or (1) 10' 9000-12248		Both Sides: 3/4-16 SAE O-Ring	
9000-42268	(1) 356-20132	(1) 8' 9000-12247 or (1) 10' 9000-12248		Both Sides: 3/4-16 SAE O-Ring	
9700-42309	(1) 356-20132	(1) 8' 9000-12247 or (1) 10' 9000-12248		Both Sides: 3/4-16 SAE O-Ring	
9000-42260	(1) 356-20132	N/A		Pressure Port: 9/16-18 SAE O-Ring Return Port: 3/4-16 SAE O-Ring	
8930-00400	(1) 356-20132	N/A		Pressure Port: 9/16-18 SAE O-Ring Return Port: 3/4-16 SAE O-Ring	
7010-69148	(1) 356-20132	N/A		Pressure Port: 9/16-18 SAE O-Ring Return Port: 3/4-16 SAE O-Ring	
9000-42200	(1) 356-20132	N/A		Pressure Port: 9/16-18 SAE O-Ring Return Port: 3/4-16 SAE O-Ring	
9000-49345	(1) 356-20132	(1) 8' 9000-12247 or (1) 10' 9000-12248		Both Sides: 3/4-16 SAE O-Ring	
7010-69084	(1) 356-20132	N/A		Pressure Port: 9/16-18 SAE O-Ring Return Port: 3/4-16 SAE O-Ring	
9000-49537	(1) 356-20132	N/A	N/A	N/A	These come with 12" 3/8" Whip Hoses so QD's will attach to hoses without fittings
9000-49538	(1) 356-20132	N/A	N/A	N/A	These come with 12" 3/8" Whip Hoses so QD's will attach to hoses without fittings
9000-02197	(1) 356-20132	N/A	N/A	N/A	These come with 12" 3/8" Whip Hoses so QD's will attach to hoses without fittings
9000-00944	(1) 356-20132	N/A	N/A	N/A	These come with 12" 3/8" Whip Hoses so QD's will attach to hoses without fittings
9000-11183	(1) 356-20132	N/A	N/A	N/A	These come with 15 1/2" Whip Hoses so 356-20088 QD Set is needed.
9000-42237	(1) 356-20132	N/A		Pressure Port: 9/16-18 SAE O-Ring Return Port: 3/4-16 SAE O-Ring	
9000-11192	(1) 356-20132	N/A		N/A	These fittings attach to the on-off valve and standard QD set will attach to these fittings
7010-69005	(1) 356-20132	N/A		Both Sides: 1/2" NPTF	
9000-99682	9000-40652 High Pressure QD's attach directly to tool 1/4-18 NPTF	N/A	N/A	N/A	
9000-42950	9000-40767 & 9000-40652 High Pressure QD's attach directly to tool 1/4-18 NPTF	N/A	N/A	N/A	
9000-49830	Low Pressure Side Fittings & QD Combo 9000-54923 & 9000-54925			High Pressure Side of Intensifier Includes 1/4-18 NPSM Couples already attached	
9701-02585					

Common Parts for Graco Reel 206-941

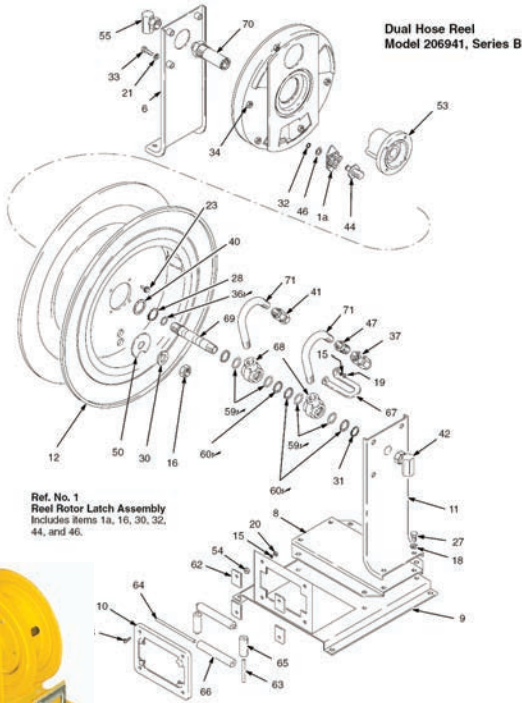

P/N 276-90002 Graco

PART NUMBER	GRACO	DESCRIPTION
276-99085	202599	REEL ROTOR LATCH ASSEMBLY
9700-49344	202465	LATCH ROTOR ASSEMBLY
9700-43646	206984	DUAL HOSE REEL SPOOL ASSEMBLY
276-99030	102790	SCREW
276-99012	101076	7/8" EXTERNAL RETAINING RING
9700-92108	155500	NITRITE RUBBER O-RING PACKING
276-99015	155865	1/2 NPT UNION STRAIGHT SWIVEL
276-99023	156024	REEL HUB SHIM, .0239" THICK
276-99013	156173	3/8 NPT UNION STRAIGHT SWIVEL
276-99006	157416	1/2 NPT UNION 90° SWIVEL
276-99031	159780	NUT, HOSE ROLLER SPACER
276-99005	159801	UNION, 90° SWIVEL, 3/8" X 1/2 NPT
276-99001	166666	NITRILE RUBBER O-RING SEAL
9700-92111	166667	BACKUP, PTFE, SWIVEL O-RING SEAL
276-99029	167029	RETAINER, ROLLER PIN
276-99028	167030	PIN, SHORT ROLLER
276-99026	167031	PIN, LONG ROLLER
276-99027	167032	ROLLER, SHORT
276-99025	167033	ROLLER, LONG
276-99007	167037	SHAFT, DUAL HOSE REEL
9700-93068	167661	ELBOW, TUBE; 3/8 NPT THD SIZE

Above are commonly used parts for the Graco Reel 206-941. Additional replacement parts for this tool are available. Please call 1-877-GO ALTEC (1-877-462-5832) for more information.

Common Parts for Hannay N-600 Series Reel

PART NUMBER	HANNAY	DESCRIPTION
7014-90044	9904.32	3/8" SPACER PIPE
9000-99210	9921.0015	SPRING MOTOR B
8936-91600	9921.0018	SPRING MOTOR C
9700-65122	9921.0021	SPRING MOTOR G
8040-01046	9921.003	SPRING MOTOR J
9700-98437	9922.0036	CAP PLUG FOR SPRING (INNER SIDE)
9701-01074	9922.0029	RATCHET PAWL ASSEMBLY "N" SERIES
9701-00656	9922.0015	RATCHET WHEEL
9701-12923	9958.0055	5/16 - 18 X 3/4" THREAD CUTTING HEX HEAD BOLT
9701-04819	9901.0671	1/2" FNPT DUAL BARSTOCK HUB ASSEMBLY
7170-40515	9927.8138	1/2" 90° MxF SWIVEL JOINT
7014-19090	9929.8551	1" 90° FxF FULL FLOW SUPER SWIVEL JOINT
9700-17322	9929.8538	1" 90° FxF BALANCED PRESSURE SUPER SWIVEL JOINT
9701-01076	9922.0001	SPRING ARBOR (D SPRING) & KEY
9700-06736	9922.0002	SPRING ARBOR (B, C, G, & J SPRING) & KEY
0276-99084	9936.0374	SEAL KIT

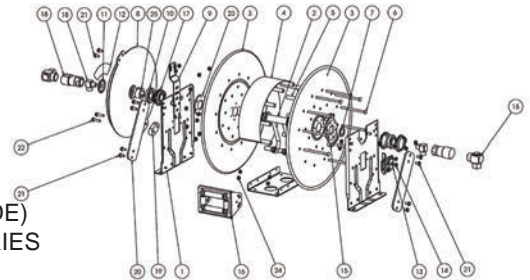

P/N 276-90058 Hannay

Above are commonly used parts for the Hannay N-600 Series Reel. Additional replacement parts for this tool are available. Please call 1-877-GO ALTEC for more information.

Back-Up Alarms

Federal Signal
Superior Signal

Battery-Powered Tools

Burndy
Dewalt
Greenlee Textron
Hilti
HK Porter
Huskie Tool
Makita
Milwaukee
Stanley

Augers & Accessories

Alaskaug, Inc.
Jeffrey Machine
Kennametal
Pengo Corp.

Compression Accessories

Alcoa
Burndy
Huskie
Greenlee Textron

Compressors

Vanair/Sullair

Electric Tools

Milwaukee

Gas Powered Tools

Echo
Stanley Tool
Stihl
Tanaka

Hand Line

New England Rope
Puget Sound Rope
Samson Rope

Hand Tools

AB Chance
Altec
CM Forge
Cementex
Cooper Tool
Fargo
Fusebuddy
Ideal
Greenlee Textron
Hisco
Jameson
Klein Tools
Lewis
Lowell
Milwaukee
Oshkosh Tools
Rauckman Utility Products
Ripley Company
Speed Systems
Tyco
Utility Tool
Wright Tool

Hot Line Tools & Equipment

AB Chance
Aircraft Dynamics
Coffing Hoist/Little Mule
Condux
Utility Solutions
Eagle Line Tools
General Machine Products
Hastings Fiberglass

Jameson
Lemco
Rauckman Utility
Salisbury
Utility Solutions

Hitches

Holland Hitch
Wallace Forge

Hydraulic Tools & Accessories

Aircraft Dynamics
Alcoa Fujikura Ltd.
Altec
B & A Manufacturing
Burndy
Greenlee Utility
Ingersoll Rand
Kearney
Magnus Industries
Parker Hannifin
Racine
Stanley Hydraulics

Ladders

Louisville Ladder
Werner Ladder

Lifting Tools

Crosby
Little Mule/Coffing Hoists
Columbus McKinnon
Harrington
Hastings
Hook International
Klein Tools
Lewis Manufacturing
Lift-All
Lincoln Hoists
Lug-All
Ruegg
Sherman-Reilly

Lighting

Arrow
AeroMotive
ATC Lighting
Code 3 - PSE Amber
Cyclops
Federal Signal
Golight, Inc.
Grote
Jameson
KH Industries
Klein Tool
Pelican
Peterson
Plastic Techniques, Inc.
Signal Stat
Star Beam
Star Headlight & Lantern
Streamlight
Superior Signal
Target Tech.
Truck Lite
Unity
Whelen

Gloves

Caiman Gloves
Klein Tools
Kunz Glove Co.
Majestic Glove Co.

Personal Equipment

Bashlin, Inc.
Buckingham Mfg.

Bulwark Protective Apparel
Capital Safety
Hoffman Boots
Klein Tools
ML Kishigo
Nasco
Rainbow Technology
Reliable Rainwear
Tingley Rubber, Inc.

Platform Accessories

Bashlin Tools
Buckingham Mfg.
Estex
Hastings
Jameson Corp.
Plastic Techniques, Inc.
Sahara Heaters
Warren Heim

Pneumatic Tools

American Pneumatic Tools
Cooper Power Systems
Paslode
Vanair/Sullair

Power Sources

AuraGen
Dimensions
Honda
Onan
Rediline
Vanner

Retractable Reels

Aircraft Dynamics
AeroMotive
Gleason
General Machine Products
Graco, Inc.
Hannay Reels
Industrial Electric Reel
Kearney
ReelTech

Safety

Aircraft Dynamics Corp.
All Safe
American Polywater Corp.
Bashlin
Bone Safety Equipment
Buckeye Fire Equipment
Buckingham Mfg.
Capital Safety
Cardiac Science
Crossfire Safety
DBI Sala
Diana Industries Int'l
Dicke
Eastern Metal
Euclid
First Aid
Igloo
Kidde
M.S.A.
Occunomix
Wolf Peak Eyewear
Sala
Saubler Mfg.
Swift
TurboFlare 360
Wolf Peak/Edge Safety

Test Equipment

AB Chance
Dillon
General Machine Products

Greenlee
HD Electric
Ideal Tool
Milwaukee Electric Tool
Rauckman Utility Products
Salisbury
Sensorlink
Skarda Equipment
STB
WMB Evans
Tree Care
Jameson

Truck Accessories

Altarnamats
Crosby
General Machine Products
Igloo
Link Manufacturing
Mobile Desk
Sauber Manufacturing
SVP Manufacturing

Underground Equipment

Condux
DCD Design
General Machine Products
Greenlee
Jameson
Lewis Manufacturing
Mopeco
Pelsue
Puregas
Ripley

Underground & Overhead

Pulling Equipment

AB Chance
Lewis Manufacturing

Truck Body Replacement Parts

Alco Machine Company
Altec
Astoria Corp.
Austin Hardware
Brand FX Body
Eberhard Mfg. Co.
Fiberbody Industries
Knapheide
Nova-Tec
United Seal & Rubber

Winches & Capstans

Bloom Manufacturing
Braden Winch Co.
DP Winch
Gear Products
General Machine Products
MY-TE Winch
Ramsey Winch

Rope & Rope Accessories

American Riggers
Bashlin
Crosby Group
Greenlee
Lift-All
Marcal Rope
New England Rope
Puget Sound
Wire Rope Co.

Worksite Equipment

Hisco
Osh Kosh
Rainbow Technology Products
Tiger

TOOL REPAIR PROGRAM

FOR HYDRAULIC, BATTERY, & MAJOR TOOLS

Repairing Tools

Return your tools to Altec Supply at the nearest address below. Upon inspection, you will immediately be contacted by a parts representative with cost and delivery information. If the repair cost exceeds 50% of a new tool, we will advise alternative options. Typically, turn around time is a matter of days unless components are not readily available. Altec maintains a large inventory of component parts to reduce long delays.

Authorized Repair Service Center

As an authorized repair service center for Greenlee/Fairmont and Stanley hydraulic tools, Altec Supply offers a combination of experience, quality, and the highest level of customer service. Our goal is to minimize customer down time caused by broken tools. In many instances, we will have a refurbished tool back in our customer's hands within 24 hours.

Altec Tool Repair Locations

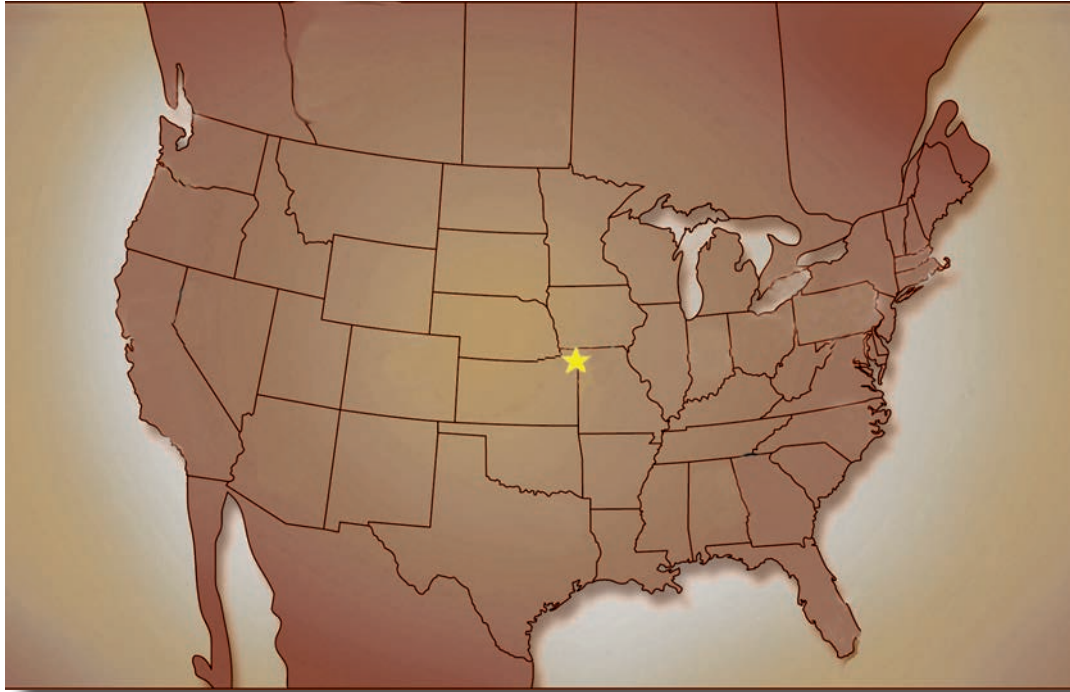

Call 1-877-GO ALTEC (1-877-462-5832)
for Hydraulic Tool Repair

Altec Industries
Tool & Component Repair
5202 Easy Hwy. 36
St Joseph, MO 64507

ALTEC SERVICE CENTERS



SERVICE CENTERS

USA: 1-877-GO ALTEC
(1-877-462-5832)

www.alteconnect.com

Alabama

1730 Vanderbilt Road
Birmingham, AL 35234
(205) 458-3839 fax

Arizona

2505 W. Durango Street
Phoenix, AZ 85009
(602) 252-8843 fax

Northern California

325 Industrial Way
Dixon, CA 95620
(707) 693-1214 fax

Southern California

2882 Pomona Boulevard
Pomona, CA 91766
(909)444-0448 fax

Colorado

641 Telluride Street
Aurora, CO 80011
(303)364-9523 fax

Florida

2570 Old Okeechobee Road
West Palm Beach, FL 33409
(561) 686-6972 fax

Georgia

287 First Street
Forest Park, GA 30050
(404) 363-2180 fax

Indiana

5201 West 84th Street
Indianapolis, IN 46268
(317) 876-3620 fax

Maryland

1434 Hughes Ford Road
Frederick, MD 21701
(301) 694-9644 fax

Massachusetts

28 Wales Street
Millbury, MA 01527
(508) 752-4791 fax

West Missouri

2106 South Riverside Road
St. Joseph, MO 64507
(816) 236-1356 fax

East Missouri

1125 South Callahan Road
Wentzville, MO 63385
(636) 639-2261 fax

Ohio

1236 Township Road 1175
Ashland, OH 44805
(419) 289-7444 fax

North Carolina

800 Hwy. 152 East
China Grove, NC 28023
(704) 856-2044 fax

Oregon

13817 N.E. Sandy Boulevard
Portland, OR 97230
(503) 253-1191 fax

Pennsylvania

250 Laird Street
Plains, PA 18705
(570) 822-7062 fax

North Texas

1001 Solon Road
Waxahachie, TX 75165
(972) 937-8253 fax

South Texas

6902 East Orem Drive
Houston, TX 77075
(713) 336-6249 fax

Crossroads Chevrolet

(Authorized Service Center)
420 S. Roth Street
Reed City, MI 49677
(231) 680-4309

Utility Equipment Specialists

(Authorized Service Center)
1111 S. 3200 W.
Salt Lake City, UT 84104
(801) 972-6168

Utility Truck Services

(Authorized Service Center)
14601 Ramsey Blvd.
Ramsey, MN 55303
(763) 323-4236

Altec Worldwide LLC

2106 South Riverside Road
St. Joseph, MO 64507
(816) 236-1369
(816) 236-1361 fax

Altec Limited - Milton

831 Nipissing Road
Milton, Ontario L9T 4Z4
(905) 875-2000
(905) 875-2009 fax

Altec Limited - Surrey

12352 84th Avenue
Surrey, British Columbia V3W 0J5
(604) 597-0355
(604) 597-0357 fax

Altec Limited - Winnipeg

570 Durand Road
Winnipeg, Manitoba R2J 3T1
(204) 663-8362
(204) 663-4798 fax

General Body & Equipment Ltd.

Calgary
3773 19th Street NE
Calgary, Alberta, Canada T2E 6S8
(403) 250-2115
(403) 250-1925 fax

General Body & Equipment Ltd.

Edmonton
8124 Davies Road
Edmonton, Alberta, Canada T6E 4N2
(780) 468-5331
(780) 468-5301 fax

Altec Parts

2106 South Riverside Road
St Joseph, MO 64507
(816) 236-1356 fax

Call 1-877-GO ALTEC (1-877-462-5832)
to reach your local parts, shop, or mobile service representative.

ALTEC SUPPLY PART NUMBER PRODUCT INDEX

**PRODUCT INDEX
BY ALTEC ITEM NUMBER**

**USA: 1-877-GO ALTEC
(1-877-462-5832)**

www.alteconnect.com

Altec P/N	Page	Altec P/N	Page	Altec P/N	Page	Altec P/N	Page	Altec P/N	Page	Altec P/N	Page
2000198	407	23545018	414	68320160	167	69296109	400	70090093	523	71610099	168
2100072	361	27129007	160	68321002	403	69296117	397	70090094	511	71800381	171
4190002	165	27129027	160	68370035	159	69296133	397	70090095	512, 524	72000001	374
9900017	165	27129444	376	68370043	166	69296140	397	70090096	524	72030034	448
9900025	165	27129457	376	68370053	166	69296145	399	70090104	528	72030035	413
9900043	23, 165	27129542	376	68370090	382	69296147	398	70090118	511	72030036	448
9900054	23, 165	27139003	160	68370154	159	69298074	162	70090121	517, 525	72030056	464
9960038	164	27139058	160	68370176	382	69298147	162	70090123	512, 523	72030057	448
10011638	404	27401154	375	68421016	208	69298276	162	70090161	525	72030075	412
23180007	172	27401155	375	68421034	208	69299207	160	70090162	525	72030078	414
23410030	174	27401851	375	68421044	208	70000009	522	70090176	512, 523	72030087	447
23411001	530	27401852	374, 375	68430008	173	70000015	522	70090180	522	72030092	447
23411024	530	27690011	160	68435003	210	70000018	415	70090182	511	72030099	412
23421005	253, 534	27690051	160	68435035	209	70000030	415	70090183	511	72030100	448
23421007	534, 535	27690058	160	68435036	209	70000032	415	70090184	511	72030116	413
23421010	534, 535	27699034	160	68435038	195	70000034	416	70090185	511	72030267	464
23421042	535	35330007	165	68435069	189	70000039	522	70090186	511	72090001	374
23421048	535	35620088	375	68435071	198-199	70000041	522	70090187	511	72090299	412
23421054	534	35620132	375	68440017	171	70000042	522	70090188	511	72090302	412
23430015	374	36000037	372	68440023	171	70000043	522	70090189	511	72090304	412
23472002	531	36000014	372	68451003	208	70000051	416	70090190	511	79100291	174
23472003	533	36000018	372	68451013	208	70000052	416	70090191	511	79100351	175
23472004	533	36000019	372	68451039	188	70000053	416	70090192	511	79100352	175
23472005	531	36000020	372	68451058	188	70000054	416	70090193	511	79100353	175
23472007	531	36009010	377	68451059	188	70000058	522	70090194	511	81100158	399
23472012	532	36020021	349	68451065	188	70000062	522	70090195	511	90005551	443
23472014	533	36020034	369	68451069	208	70000063	530	70090196	511	97011842	240
23472015	532	36020035	369	68451081	188	70000066	416	70090197	511	97058887	81
23472017	532, 533	36029003	377	68451137	197	70009001	521	70090198	511	200000041	173
23472019	531	36029004	377	68451161	197	70009002	523	70090205	511	200000042	173
23472021	531	36030001	369	68451218	188	70009003	521	70090225	511	213040001	173
23472022	531	36030010	369	68455010	210	70009007	521	70090228	524	213040002	173
23472032	531	36030013	369	68455024	187	70009008	513, 524	70090229	524	213040003	173
23472035	531	36030013	379	68455025	187	70009011	522	70090246	529	317201205	22, 167
23475001	531	36030021	354	68491001	167	70020291	534	70090314	520	317402906	167
23475002	531	36039001	377	68500005	139	70090049	511	70090315	520	317800112	167
23475003	532	36039004	377	68500012	28, 139	70090050	511	70090316	520	319400201	161
23475004	532	36039007	377	68500015	28, 137	70090051	511	70400100	134	319905040	173
23475005	532	36039050	377	68500016	169	70090052	511	70400101	134	319905041	173
23475006	533	36060001	370	68500025	28, 139	70090053	511	70420066	135	322500102	168
23475007	533	41480003	223	68500077	139	70090054	511	70420067	135	322500103	168
23476002	531	41501079	161	68520154	397	70090055	511	70420069	135	322500107	168
23476007	531	41510000	221	69292100	171	70090056	511	70420070	135	330000901	173
23476014	531	41511000	223	69293055	23, 140	70090057	511	70420071	135	527500037	169
23476015	531	41511001	223	69293078	23, 140	70090058	511	70420074	132	701069005	355
23476019	531	41520154	534	69293081	23, 140	70090060	526	70420091	122, 134	701069017	358
23476021	531	59650009	168	69293099	23, 140	70090061	512, 523	70420132	423, 424	701069018	358
23476065	531	60410029	382	69293117	23, 140	70090062	512, 524	70420302	122, 134	701069023	349
23476069	531	60460002	143	69293118	23, 140	70090063	512, 524	70420353	164	701069084	354
23476076	531	60460006	143	69293119	23, 140	70090065	521	70420399	168	701069149	358
23476081	532	60460033	382	69293163	174	70090066	521	70420409	168	701069155	358
23476082	532	60600019	168	69293172	174	70090067	521	70420456	125	701110017	208
23476083	532	60690005	168	69296011	402, 403	70090068	521	70420463	164	701122129	143
23476084	532	60820003	173, 209	69296014	403	70090069	521	70420648	122	701122131	143
23476085	532	60870026	169, 189	69296057	398	70090070	521	70420695	135	701209003	144
23476086	533	60870040	169	69296058	397	70090071	521	70420810	135	701300035	221
23476087	533	66001017	140	69296059	397	70090072	521	70420871	56	701300036	223
23476088	531	66001044	140	69296066	396	70090073	521	70420884	132	701300040	221
23477002	531	66002001	164	69296067	396	70090074	521	70420938	135	701700150	132
23477013	532	66002029	164	69296068	396	70090075	521	70420940	135	701702080	448
23477014	532	66010001	31	69296069	161, 410	70090076	521	70421071	164	701702085	448
23477015	532	66010004	31	69296070	161, 410	70090077	521	70421244	45	701703102	135
23477016	532	66021028	22, 167	69296071	161, 410	70090079	511	70450080	172	701705033	514
23480004	249, 530	66021045	22	69296072	158, 410	70090080	511	70680005	135	701705044	529
23480005	249, 530	66021048	20	69296073	158, 410	70090081	511	70680049	135	701705071	529
23490004	535	66030002	31	69296074	158, 410	70090082	511	70680468	135	701705072	529
23490005	535	66030007	40	69296075	158, 410	70090083	511	70680469	135	701705073	529
23490006	535	66060009	23, 165	69296076	158, 410	70090084	511	70680472	135	701705078	529
23490007	535	66060011	23, 134, 165	69296077	158, 410	70090085	511	70680616	135	701993009	132
23545009	414	68300116	343, 376	69296086	401	70090086	511	71610068	168	701993015	123
		68320006	167	69296087	401, 402	70090087	511	71610069	168	705000344	371
				69296106	398	70090091	512, 524	71610098	168	705000345	371



PRODUCT INDEX BY ALTEC ITEM NUMBER

USA: 1-877-GO ALTEC
(1-877-462-5832)

www.alteccconnect.com

Altec P/N	Page
705201079	188
705201144	129, 176
705201161	407
705201162	407
705201178	156
705201181	407
705201182	404
705201231	129, 176
705201292	407
705201298	187
705201335	406
705201491	198-199
705201715	195
705300768	346
705300769	346
705300770	346
705300771	346
705300773	346
705300775	346
705300776	346
705300777	346
705300778	346
705300779	346
705300780	346
705300781	346
705300782	346
705300784	346
705300785	346
705300786	346
705300787	346
705300788	346
705300789	346
705300790	346
705300791	346
705300793	346
705300794	346
705300796	346
705300799	346
705301209	162
705301443	167
705400094	122
705400108	416
705400193	529
705400199	528
705400223	528
705400287	128, 573
705400515	233
705400562	562
705400575	529
705400607	417
716030528	446
716030535	448
716030542	24
716030543	24, 162, 446
716030546	24
716201070	361
716302003	526
716302043	512
716302044	512
716302051	512
716302054	512
716302087	521
716302088	521
716302090	524
716302091	524
716302092	524
716302096	518
716302105	523
716302107	523
716302119	512
716302120	512
716302123	512
716302126	521
716302127	521
716302128	521
716302129	521
716302160	523

Altec P/N	Page
716302173	512
716320005	525
717320205	195
717330015	198-199
717330018	198-199
717330034	198-199
800100002	172
800100004	171
800100007	173
800100016	172
800100017	59, 558
800100056	172
800100062	170
800100081	170
800100095	170
800100096	170
800100102	173
800100105	170
800100106	170
800100116	170
800100136	170
800100146	170
800100164	172
800100188	173
800100548	171
800100549	171
800100550	171
800100551	171
800100552	171
800100553	171
800100554	171
800100555	171
800100556	171
800100557	171
800100588	171
800100908	170
800101758	170
800101944	172
800101964	171
800101980	172
800101982	170
800102326	172
800102342	172
800902000	170
804000337	223
809500204	128, 133, 573
809500274	354, 357
809500416	349
809500549	369
810000001	173
810000540	188
810001061	195
811000580	158, 410
811000966	407
811001042	404
811001059	397
811001060	397
811001191	397
811001231	188
811001559	407
811001674	408
812604810	368
812606538	377
812606610	372
812607641	372
812607683	372
812608347	372
812608348	372
812608531	369
812620300	349
812620531	371
812621511	371
812640276	377
812645130	370
812645150	370
812645550	370
812667130	370

Altec P/N	Page
813000204	128
813000205	128, 573
813000308	534
813000428	128, 133, 573
813000603	135
813000720	514
813000807	447
813000873	447
813001010	132
814000371	24, 162, 446
814000372	24, 162, 446
814000373	24, 162, 446
814000728	140
814000947	168
818000005	173
818000214	346
818000620	157
870261354	132
878010489	128, 133, 573
878070912	401, 406
878070982	402, 407
878071022	397
878071067	143
878660011	140
878660059	169
878660060	162
885102711	135
885120004	135
885532328	377
893000400	354
893020500	354
893507700	523
893803660	563
893851410	521
893852310	371
893882850	248
893882851	248
893882852	248
893882853	248
893882854	248
893882855	248
893891150	372
893911970	187
893914080	188
893931370	248
893931380	248
893931390	248
893940080	563
893942880	401
893943170	208
893951500	143
893964100	143
894002400	529
896021700	416
899408300	512, 523
900000045	483
900000064	483, 485
900000065	485
900000066	485
900000071	485
900000073	486
900000074	486
900000075	486
900000076	486
900000082	482
900000083	482
900000084	482
900000141	483
900000143	483
900000154	483
900000162	486
900000163	486
900000164	486
900000176	298
900000182	26

Altec P/N	Page
900000191	27
900000192	27
900000193	26
900000194	26
900000200	31
900000201	31
900000213	28, 137
900000214	574
900000215	22, 164, 574
900000216	22, 164, 574
900000230	443
900000235	443
900000258	234
900000259	234
900000267	234
900000268	234
900000269	235
900000277	494
900000278	494
900000279	494
900000280	494
900000281	494
900000282	494
900000283	494
900000284	494
900000285	494
900000286	494
900000287	494
900000288	494
900000289	494
900000290	494
900000291	494
900000293	494
900000294	494
900000295	110, 572
900000296	110, 572
900000297	110, 572
900000298	110, 572
900000299	110, 572
900000313	494
900000314	494
900000315	494
900000316	494
900000317	494
900000319	493
900000320	493
900000321	498
900000322	498
900000323	498
900000324	498
900000326	501
900000327	501
900000328	501
900000329	501
900000330	501
900000331	501
900000332	497
900000333	497
900000334	497
900000335	497
900000336	497
900000337	497
900000338	497
900000339	497
900000340	497
900000341	497
900000342	501
900000343	504
900000344	501
900000345	501
900000346	466
900000347	501
900000348	554
900000350	20
900000351	490
900000352	490

Altec P/N	Page
900000353	490
900000354	490
900000356	490, 492
900000357	492
900000358	490
900000359	490
900000361	490
900000362	490
900000364	490
900000372	490
900000373	490
900000374	490
900000375	490
900000384	109, 572
900000385	109, 572
900000386	109, 572
900000387	275, 556
900000394	296
900000418	481
900000419	481
900000420	481
900000421	481
900000422	481
900000426	483
900000427	297
900000428	544
900000429	314
900000431	314
900000433	314
900000434	314
900000439	116
900000440	116
900000443	234
900000447	369
900000448	369
900000449	369
900000454	20
900000470	234
900000480	110, 572
900000501	171
900000502	171
900000503	171
900000504	171
900000505	171
900000507	171
900000508	171
900000509	171
900000510	171
900000521	575
900000522	575
900000525	461
900000526	461
900000531	466
900000533	525
900000535	124
900000537	293
900000545	171
900000546	444
900000568	129
900000569	343
900000573	267
900000575	110, 572
900000576	110, 572
900000577	110, 572
900000593	572
900000594	110, 572
900000595	110, 572
900000610	40
900000706	294
900000756	295
900000758	296
900000773	295
900000774	295
900000800	26
900000852	109
900000854	111
900000855	111

Altec P/N	Page
900000856	111
900000857	111
900000918	254
900000944	355
900000963	110, 572
900000964	110, 572
900001005	108
900001006	125
900001007	108
900001008	505
900001009	108
900001010	286
900001016	369
900001037	404
900001054	111
900001055	111
900001056	111
900001057	111
900001061	109
900001062	109
900001063	109
900001064	109
900001065	109
900001066	109
900001067	109
900001071	109
900001072	109
900001074	109
900001075	109
900001110	571
900001120	571
900001140	571
900001141	570
900001150	570
900001222	570
900001224	570
900001245	570
900001246	570
900001247	570
900001248	570
900001249	570
900001250	468
900001253	468
900001256	468
900001300	

Altec P/N	Page
900002025	108
900002026	108
900002027	108
900002032	108
900002033	108
900002034	108
900002035	108
900002036	108
900002050	111
900002051	111
900002053	111
900002058	111
900002064	298
900002065	298
900002080	443
900002090	279, 280
900002093	279, 280
900002101	401
900002120	443
900002121	469
900002157	404
900002160	443
900002166	443
900002178	314
900002193	264
900002197	356
900002198	356
900002201	356
900002212	279, 280
900002230	284
900002240	281
900002250	443
900002300	443
900002301	443
900002350	443
900002415	133
900002424	443
900002500	443
900002510	284
900002528	414
900002529	414
900002530	414
900002536	414
900002538	434
900002568	434
900002622	397
900002641	429
900002990	403
900003046	429
900003114	444
900003115	444
900003116	444
900003118	444
900003119	444
900003120	444
900003150	569
900003165	508
900003250	569
900003500	442
900003551	233
900003552	310
900003556	233
900003600	569
900003840	111
900003841	109, 572
900003842	109, 572
900004001	378
900004012	221
900004030	467
900004241	111
900004370	409
900004405	210
900004455	429
900004500	218
900004569	570
900004570	118
900004601	444

Altec P/N	Page
900004602	444
900004604	445
900004606	445
900004608	445
900004769	553
900004946	320
900005250	569
900005386	351
900005460	444
900005462	444
900005464	444
900005466	444
900005468	444
900005558	445
900005676	445
900005678	445
900005923	294
900006004	262
900006006	262
900006008	262
900006012	262
900006017	571
900006034	262
900006036	262
900006050	471
900006090	134
900006116	403
900006265	125
900006403	429
900006409	140
900006688	302
900006767	408
900006867	493
900006930	568
900007033	313, 315
900007035	313, 315
900007036	313, 315
900007150	568
900007280	140
900007379	342, 345
900007600	568
900007628	20
900007815	368
900007886	509
900008104	442
900008106	442
900008110	442
900008112	442
900008142	38
900008158	442
900008160	298
900008161	298
900008172	492, 493
900008526	109
900008528	109
900008546	444
900008570	544
900008690	304
900009000	469
900009006	267
900009056	267
900009258	513
900009350	37
900010016	449
900010017	449
900010018	449
900010019	449
900010022	449
900010025	445
900010036	445
900010038	445
900010044	449
900010090	446
900010100	571
900010101	571
900010142	494
900010143	494

Altec P/N	Page
900010144	494
900010145	494
900010146	494
900010150	54, 563
900010167	343, 376
900010169	446
900010170	343, 376
900010171	446
900010173	343, 376
900010174	343, 376
900010175	343, 376
900010176	343, 376
900010177	343, 376
900010179	343, 376
900010180	343, 376
900010188	446
900010227	526
900010258	513
900010461	481
900010476	404
900010500	508
900010501	508
900010502	508
900010507	294
900010553	509
900010604	351, 353
900010727	166, 503
900011000	449
900011001	129, 309
900011100	134
900011101	43
900011103	43
900011107	43
900011108	43
900011109	43
900011110	571
900011112	43
900011120	571
900011140	571
900011168	480
900011183	354
900011192	355
900011193	355
900011200	128
900011201	128
900011203	128
900011215	225
900011500	130
900011510	130
900011515	130
900011520	130
900011530	130
900011540	130
900011542	480
900011550	130
900011575	511
900011576	511
900011578	511
900011579	511
900011582	523
900011583	448
900011584	448
900011600	283
900011610	283
900011700	124
900011800	164
900011806	257
900011910	129
900011920	129
900011990	305
900012247	376
900012248	376
900012258	513
900012282	405
900012400	248
900012430	570
900012433	570

Altec P/N	Page
900012434	570
900012435	570
900012436	570
900012437	570
900012438	570
900012439	570
900012440	570
900012441	570
900012442	568
900012443	568
900012530	468
900012545	468
900012600	248
900012800	248
900013010	417
900013350	445
900013351	445
900013352	445
900013353	445
900013354	445
900013355	445
900013356	445
900013357	445
900013412	442
900013413	442
900013414	442
900013415	442
900013698	111
900013765	409
900014000	571
900014001	571
900015000	283
900015010	218
900015060	468
900015200	283
900015251	461
900015258	513
900015470	166, 501
900015471	505
900015472	166, 501
900015475	505
900015479	166, 501
900015703	268
900016021	569
900016022	569
900016041	212, 215
900016042	212
900016112	212
900016113	212
900016114	212
900016115	212
900016134	212
900016200	344
900016252	212
900016258	513
900016281	212
900016287	212
900016288	212
900016562	211
900016563	211
900016564	211
900016565	211
900016594	212
900016597	211
900016711	213
900016712	213
900016846	212
900016847	211
900016853	213
900016861	213
900016925	212
900017022	234
900017091	493
900017092	493
900017093	493
900017094	493
900017600	429

Altec P/N	Page
900017601	429
900017602	429
900017604	429
900017620	429
900017630	429
900017660	429
900017908	429
900017910	429
900017912	429
900018007	445
900018008	445
900018023	235
900018024	235
900018258	513
900018912	431
900018913	431
900018915	431
900018916	431
900019148	249
900020001	374
900020009	264
900020025	369
900020031	111
900020032	111
900020048	264
900020120	443
900020144	375
900020145	375
900020160	443
900020200	37
900020235	108
900020245	108
900020255	108
900020265	108
900020275	108
900020326	108
900020336	108
900020346	108
900020356	108
900020366	108
900020509	111
900020513	111
900020518	111
900020521	480
900020800	219
900020900	279, 280
900020923	445
900020925	445
900020926	445
900020927	445
900020930	279, 280
900021064	432
900021100	176
900021101	176
900021105	176
900021106	176
900021110	176
900021111	176
900021115	176
900021116	176
900021172	468
900021222	573
900021292	26
900021303	424
900021315	468
900021393	264
900021500	209
900021546	405
900021600	573
900021601	478
900021610	573
900021615	478
900021641	429
900021690	478
900021695	478
900021810	141
900021910	210

Altec P/N	Page
900021990	210
900022100	279, 280
900022131	314
900022200	443
900022220	26
900022221	26
900022222	26
900022223	26
900022300	279, 281
900022301	281
900022396	361
900022403	429
900022415	568
900022416	568
900022435	568
900022436	568
900024000	279, 281
900024041	128, 573
900024258	513
900024406	21, 574
900024407	21, 574
900024427	21, 574
900024432	21, 574
900024470	505
900024471	505
900024564	294
900025000	38
900025412	569
900025809	514
900025812	514
900025816	514
900025818	514
900025820	514
900025830	514
900026006	166, 205
900026007	166, 205
900026403	429
900027150	125
900027155	125
900027550	125
900027555	125
900028024	248
900028026	248
900028028	248
90002	

Altec P/N	Page	Altec P/N	Page	Altec P/N	Page	Altec P/N	Page	Altec P/N	Page	Altec P/N	Page
900030467	429	900032096	428	900040004	102	900042558	567, 568	900050259	409	900054560	511
900030468	429	900032097	428	900040005	102	900042640	429	900050304	122-123	900054563	511
900030501	571	900032133	428	900040006	102	900042641	429	900050320	123	900054564	511
900030613	432	900032136	430	900040007	102	900042766	131	900050324	568	900054566	511
900030614	432	900032137	430	900040008	102	900042853	358	900050340	123	900054570	511
900030694	361	900032205	427	900040009	102	900042909	358	900050363	450	900054571	511
900030704	432	900032403	429	900040010	102	900043059	413	900050369	82	900054600	511
900030814	432	900032419	522	900040011	102	900043973	358	900050370	82	900054601	511
900030903	221	900032520	569	900040012	102	900044550	429	900050371	82	900054602	511
900030982	416	900032543	424	900040019	419	900044552	432	900050372	82	900054605	511
900031000	480	900032550	569	900040022	102	900044556	432	900050373	82	900054606	511
900031017	427	900032600	427	900040023	102	900044558	435	900050374	82	900054607	511
900031018	427	900032601	427	900040024	102	900044559	432	900050385	376	900054608	511
900031019	427	900032602	427	900040025	118	900044566	432	900050386	376	900054609	511
900031020	427	900032603	427	900040027	118	900044500	380	900050387	285	900054610	511
900031021	427	900032604	427	900040028	118	900045085	259	900050399	408	900054611	511
900031022	427	900032605	427	900040029	118	900045120	124	900050467	19	900054620	511
900031023	427	900032609	522	900040031	103	900045206	295	900050501	123	900054621	511
900031025	426	900032610	569	900040032	103	900045207	295	900050506	123	900054626	511
900031036	426	900032984	522	900040033	103	900045240	297	900050511	123	900054628	511
900031085	430	900032996	432	900040034	103, 480	900045331	570	900050516	123	900054630	511
900031086	430	900033009	430	900040035	103	900045378	314	900050526	346	900054631	511
900031112	430	900033060	426	900040036	103	900045462	444	900050549	346	900054680	516
900031113	430	900033061	426	900040037	103	900045567	435	900050550	563	900054681	516
900031148	255	900033349	427	900040038	103, 480	900045585	435	900050561	342, 345	900054684	516
900031181	255	900033350	427	900040039	103	900045648	469	900050710	266	900054685	516
900031200	132	900033600	514	900040040	103	900046000	435	900050711	266	900054687	516
900031210	132	900033601	514	900040041	103	900046010	445	900050712	266	900055191	359
900031223	417	900033602	514	900040042	103, 480	900046012	445	900050713	266	900055366	26
900031226	417	900033603	514	900040046	118	900046781	444	900050743	414	900055410	444
900031227	417	900033604	514	900040090	423	900046782	444	900050744	417	900055416	444
900031230	132	900033606	514	900040090	398	900046784	444	900050745	417	900055418	444
900031270	132	900033607	516	900040119	513, 524	900046786	444	900050747	417	900055461	444
900031340	418	900033860	111	900040163	176	900046788	429, 444	900050748	417	900055464	444
900031382	425	900034000	342, 345	900040164	176	900046801	444	900050749	543	900055466	444
900031419	306	900034039	514, 517, 526	900040302	423, 424	900046802	444	900050910	131	900055468	444
900031597	427	900034053	520, 525	900040315	423	900046804	444	900050925	131	900055471	444
900031598	427	900034061	520, 526	900040320	428	900046808	444	900050940	131	900055474	444
900031599	427	900034091	526	900040334	440	900047538	26	900050945	131	900055476	444
900031600	427	900034356	372	900040400	423	900048057	422	900051103	123	900055478	444
900031601	427	900034797	522	900040569	514	900048060	419	900051273	512, 523	900056150	516
900031602	427	900035778	342, 345	900040600	467	900048072	419	900051311	123	900056160	516
900031612	432	900035780	342, 345	900040601	467	900048091	419	900051630	268	900056170	516
900031614	432	900035783	342, 345	900040602	466	900048254	377	900052000	283	900056175	516
900031739	427	900035784	342, 345	900040629	466	900048313	377	900052502	569	900056180	516
900031822	432	900035785	342	900040647	360	900048735	353	900052505	569	900056185	516
900031850	432	900035786	342, 345	900040652	360	900048750	353	900052506	569	900056200	516
900031851	432	900035787	342, 345	900040919	254	900048820	353	900053000	283	900056215	516
900032046	428, 432	900035788	342, 345	900041104	135	900048824	353	900053020	59, 558	900056403	429
900032047	428	900035789	342, 345	900041189	357	900049334	357	900053400	522	900056500	516
900032048	428	900035790	342, 345	900041219	357	900049345	353	900053402	522	900056505	516
900032049	428	900035792	342, 345	900041220	357	900049358	377	900053403	522	900056510	516
900032050	428	900035793	342, 345	900041231	372	900049499	357	900053700	502	900056520	516
900032051	428	900035794	342, 345	900041400	127	900049532	354	900053701	502	900056525	516
900032052	428	900035795	342, 345	900041500	127	900049533	354	900053702	502	900056530	516
900032053	428	900035796	342, 345	900041509	419	900049534	354	900053703	502	900056535	516
900032054	428	900036258	513	900041510	127	900049537	356	900053704	502	900056540	516
900032055	428	900036981	111	900041777	375	900049538	356	900053705	502	900056545	516
900032056	428	900036987	111	900041780	375	900049566	359	900054110	445	900056550	516
900032057	428	900036988	111	900041795	361	900049603	359	900054112	445	900056555	516
900032058	428	900036989	111	900041877	360	900049618	360, 383	900054114	445	900056560	516
900032059	428	900037350	523	900041937	423	900049830	361	900054116	445	900056565	516
900032061	428	900037415	292	900041938	423	900050000	283	900054118	445	900056570	516
900032062	428, 432	900037521	520	900041941	360	900050094	343	900054120	445	900056575	515
900032063	428	900037523	520	900042000	151	900050096	343	900054160	445	900056576	515
900032064	428	900037524	520	900042036	263	900050110	445	900054180	445	900056580	515
900032065	428	900037527	520	900042037	263	900050112	445	900054205	522	900056581	515
900032066	428	900037750	526	900042096	360	900050140	445	900054233	521	900056585	515
900032067	428	900037868	350	900042105	357	900050157	284	900054240	521	900056586	515
900032068	428	900037869	350	900042184	353	900050160	445	900054241	521	900056595	515
900032069	428	900037870	350	900042190	357	900050178	243	900054242	521	900056596	515
900032070	428	900037871	350	900042192	357	900050179	243	900054321	513	900056600	515
900032071	428	900038400	248	900042200	354	900050180	445	900054330	513	900056601	515
900032072	428	900038568	358	900042237	354	900050193	379	900054331	513	900056605	515
900032073	428	900038600	248	900042260	349	900050210	263, 264	900054332	513	900056606	515
900032074	428	900039009	377	900042501	567	900050212	264	900054335	513	900056610	515
900032095	428	900040000	151			900050214	153	900054338	513	900056611	515

PRODUCT INDEX BY ALTEC ITEM NUMBER

USA: 1-877-GO ALTEC
(1-877-462-5832)

www.alteconnect.com

Altec P/N	Page	Altec P/N	Page	Altec P/N	Page	Altec P/N	Page	Altec P/N	Page	Altec P/N	Page
900056615	515	900064551	469	900070308	86	900070575	50	900081429	38	900096212	378
900056616	515	900065400	135	900070309	86	900070588	49	900081460	509	900096214	379
900056620	515	900065462	444	900070310	86	900070592	86	900081580	442	900096216	379
900056621	515	900065703	123	900070311	86	900070607	82	900081641	429	900096219	379
900056625	515	900066050	504	900070312	86	900070609	82	900081814	442	900096235	22
900056626	515	900066051	504	900070327	140	900070645	378	900081816	269	900096403	429
900056630	515	900066403	429	900070329	503	900070656	49	900081829	311	900099000	523
900056631	515	900066666	530	900070343	86	900070657	86	900081830	311	900099316	176
900056635	515	900066667	530	900070344	86	900070658	86	900081833	310	900099319	132
900056636	515	900066668	530	900070351	166, 501	900070659	86	900081834	310	900099328	167
900056640	515	900066669	530	900070352	504	900070660	86	900081838	310	900099345	135
900056641	515	900066780	431	900070368	497	900070661	408	900082815	129	900099346	135
900056645	515	900067010	135	900070369	493	900071022	498	900083698	111	900099360	415
900056646	515	900068202	265	900070370	495	900071399	502	900084453	499	900099370	411
900059002	131	900068203	265	900070371	495	900071400	502	900084454	499	900099377	572
900059022	125	900068204	265	900070372	495	900071401	502	900084513	309	900099378	572
900060002	571	900068410	135	900070373	495	900071402	502	900085000	37	900099383	572
900060003	571	900068592	497	900070374	495	900071403	502	900085076	262	900099384	572
900060006	571	900068593	497	900070375	495	900071404	502	900085462	444	900099385	572
900060008	571	900068595	497	900070376	495	900071405	502	900086403	429	900099386	572
900060011	571	900068596	497	900070377	495	900071406	502	900086570	497	900099387	572
900060012	571	900068710	127	900070378	495	900071408	502	900086571	497	900099388	572
900060197	395, 399	900069338	306	900070379	495	900071533	185	900087000	37	900099410	221
900060201	218	900069381	306	900070381	495	900071530	508	900088830	499	900099413	571
900060205	218	900069382	306	900070382	495	900071531	508	900088831	499	900099415	27
900060220	443	900069384	306	900070383	495	900071532	508	900088833	310	900099416	27
900060309	466	900069437	306	900070384	495	900071533	508	900088834	311	900099417	27
900060501	571	900069611	306	900070385	495	900071534	508	900088835	311	900099418	27
900060503	571	900069633	306	900070386	495	900071535	508	900088845	56	900099419	27
900060506	571	900069667	306	900070387	495	900071575	524	900088858	208	900099420	27
900060508	571	900069684	306	900070388	495	900071643	500	900088874	381	900099421	27
900060510	498	900069847	306	900070389	495	900071644	500	900088893	266	900099422	27
900060512	498	900069947	306	900070390	495	900071645	500	900088894	305	900099424	27
900060515	498	900070001	499	900070391	495	900071647	504	900088895	212	900099427	370
900060520	498	900070002	499	900070392	495	900071710	500	900088896	269	900099428	370
900060530	571	900070003	499	900070393	495	900071711	500	900088910	212	900099454	244
900060560	571	900070004	499	900070394	495	900071712	500	900088911	213	900099455	244
900060580	499	900070005	499	900070395	495	900071713	500	900088912	211	900099456	244
900060581	499	900070006	499	900070396	495	900071714	500	900088931	108	900099457	244
900060582	499	900070007	499	900070397	495	900071715	500	900088933	108	900099460	244
900060583	499	900070008	499	900070398	501	900071721	500	900088954	189	900099465	242
900060584	499	900070009	499	900070399	501	900071722	500	900089000	37	900099468	241
900060585	499	900070024	305	900070401	501	900071723	500	900090002	264	900099469	241
900060586	499	900070065	560	900070402	501	900071724	500	900090090	14	900099470	241
900060587	499	900070125	509	900070403	501	900071725	500	900090091	14	900099471	241
900060590	499	900070129	185	900070407	493	900071726	500	900090092	15	900099472	241
900060591	499	900070136	497, 507	900070408	493	900071727	500	900090093	14	900099473	241
900060592	499	900070137	497	900070409	493	900071728	500	900090438	221	900099474	242
900060593	499	900070138	497	900070410	493	900071729	500	900090439	221	900099475	242
900060596	499	900070139	497	900070411	493	900072400	130	900090440	221	900099476	242
900060597	499	900070140	497	900070412	493	900072401	130	900090441	221	900099477	242
900060598	499	900070151	493	900070413	493	900072405	130	900090442	221	900099478	242
900060599	499	900070152	493	900070414	498	900073500	568	900091604	509	900099479	242
900060600	499	900070153	493	900070415	498	900073600	568	900091605	516	900099483	242
900060791	377	900070154	493	900070416	498	900073698	111	900091607	531	900099484	242
900061007	181	900070156	493	900070417	498	900074530	504	900092000	263	900099485	242
900061050	181	900070157	493	900070418	498	900074531	504	900093059	37, 561	900099486	242
900061100	571	900070175	140	900070419	498	900075360	26	900093078	23, 140	900099489	349, 373
900061200	571	900070181	51	900070420	498	900075369	26	900093698	111	900099493	314
900061301	181	900070188	502	900070421	498	900076403	429	900096150	118	900099494	492
900061400	571	900070190	508	900070422	498	900076543	302	900096155	415	900099495	492
900061641	429	900070191	502	900070423	498	900080002	344	900096159	219	900099496	492
900061754	398, 403	900070202	503	900070424	498	900080024	22, 167	900096164	127, 309	900099497	492
900061798	400, 403	900070210	116	900070425	498	900080332	269	900096165	127, 309	900099498	492
900062618	403	900070222	290	900070426	498	900080771	498	900096173	344	900099499	492
900063001	415	900070265	389	900070427	498, 507	900080773	498	900096179	373	900099500	492
900063002	415	900070266	389	900070428	498	900080775	498	900096183	320	900099501	492
900063045	301	900070274	166, 205	900070429	498, 507	900080777	498	900096185	127, 309	900099502	492
900063050	300	900070276	166, 205	900070434	498	900080779	498	900096192	208, 464	900099503	492
900063060	300	900070277	166, 205	900070435	500	900080820	269	900096196	117	900099504	492
900063118	301	900070278	166, 205	900070436	500	900080856	223	900096197	379	900099505	492
900063124	301	900070283	499	900070437	500	900080900	222	900096198	378	900099509	485, 487
900063130	301	900070284	499	900070438	500	900080920	504	900096199	379	900099510	486
900063136	301	900070285	499	900070439	500	900080921	504	900096200	29	900099511	486
900063324	301	900070298	498	900070440	500	900080975	499	900096201	29	900099512	486
900063330	301	900070299	498	900070441	503	900081180	222	900096202	29	900099513	486
900063336	301	900070300	498	900070571	86	900081335	223	900096210	379	900099514	486



PRODUCT INDEX BY ALTEC ITEM NUMBER

USA: 1-877-GO ALTEC
(1-877-462-5832)

www.alteccconnect.com

Altec P/N	Page
900099515	486
900099516	486
900099517	486
900099518	486
900099519	486
900099520	486
900099521	486
900099522	486
900099523	486
900099524	486
900099525	486
900099526	485
900099526	486
900099527	485
900099527	486
900099535	117
900099536	117
900099537	117
900099538	117
900099542	492
900099543	492
900099544	492
900099545	492
900099546	492
900099547	492
900099548	492
900099549	492
900099550	492
900099551	492
900099552	492
900099553	492
900099554	492
900099555	492
900099556	492
900099557	492
900099558	492
900099559	492
900099560	492
900099561	293
900099562	291, 293
900099563	293
900099564	293
900099578	253
900099579	253
900099580	253, 534
900099581	253, 534
900099582	253, 534
900099583	483
900099584	492
900099598	31
900099599	31
900099600	56
900099601	24, 162, 446
900099602	24, 162, 446
900099604	31
900099605	31, 54, 563
900099613	434
900099623	171
900099624	171
900099625	171
900099626	171
900099627	171
900099628	171
900099629	171
900099630	171
900099631	171
900099632	171
900099633	171
900099641	543
900099643	542
900099644	542
900099646	540
900099652	540
900099654	540
900099655	541

Altec P/N	Page
900099656	541
900099657	541
900099658	541
900099664	544
900099665	544
900099666	545
900099667	545
900099668	545
900099669	545
900099670	545
900099671	545
900099673	545
900099674	418
900099676	469, 553
900099677	553
900099678	553
900099681	512
900099682	361
900099683	417
900099684	417
900099706	411
900099713	21, 574
900099714	21, 574
900099715	21, 574
900099716	21, 574
900099718	530
900099719	21, 574
900099720	416
900099795	349
900099796	349
900099797	522
900099807	377
900099824	233
900099825	38
900099831	384
900099863	417
900099868	536
900099871	434
900099875	302
900099877	377
900099890	377
900099898	377
900099908	526
900099915	520
900099923	21, 574
900099924	21, 574
900099934	520
900099935	520
900099943	377
900099953	520
900099956	38
900099959	135
900099983	135
900700090	305
900700096	248
900700100	218
900700123	218
900700130	218
900700140	218
900700200	110
900700300	220
900700950	540
900701027	237
900701700	290, 293
900702044	237
900702046	237
900702048	237
900702050	237
900702052	237
900702256	400
900702609	397
900703000	248
900703412	398
900703480	442
900704367	469, 553
900704469	469, 553

Altec P/N	Page
900704604	444
900706250	116
900706702	552
900707534	541
900708690	304
900710020	449
900710021	449
900710091	446
900710184	253, 534
900711001	396
900711006	443
900711660	116
900712594	443
900715422	290, 293
900716718	116
900717605	435
900718023	235
900718762	544
900720509	111
900730811	222
900731416	435
900736001	293
900738800	248
900740228	117
900740308	544
900740314	435
900740329	306
900740558	117
900740600	466
900741085	237
900741703	222
900744551	436
900744554	435
900744556	436
900744557	436
900744558	435
900750621	139
900760015	402
900760100	397
900763041	301
900767021	552
900786900	304
970004250	208
970004588	26
970004589	26
970004923	169
970004923	169
970004962	313, 315
970005084	397
970005496	443
970005613	345
970005619	344
970005624	344
970005627	344
970005628	344
970005649	464
970005650	464
970005979	26
970006166	522
970006218	174
970006365	343, 376
970006663	377
970010785	373
970011275	187
970012295	359
970012731	536
970012780	174
970012892	296
970012920	315
970012948	296
970013097	397
970013228	313
970013302	373
970014174	361
970014402	377
970014407	377
970014414	377

Altec P/N	Page
970014415	377
970014416	377
970014873	197
970015011	302
970015444	310
970015444	309
970015445	309, 310
970015446	308, 320, 343, 376
970016074	518
970016176	442
970016339	471
970016341	466
970016745	175
970016746	175
970016829	281
970017027	357
970017048	281
970017137	369
970017137	379
970017288	259
970017580	174
970018058	281
970018061	281
970018231	37
970018234	471
970018238	305
970018791	516
970018946	399
970019180	281
970019302	361
970020224	266
970020535	518
970020544	303
970020545	346
970020598	21, 574
970020643	21, 574
970020644	20, 574
970020722	20, 574
970020729	20, 574
970020800	164
970020801	164
970020869	268
970021026	574
970021641	313
970021683	413
970021736	314
970021953	38
970021965	220
970021966	220
970022314	267
970022454	467
970022458	467
970022541	266
970022542	266
970023352	38
970023390	449
970023393	233
970024788	346
970026860	222
970026881	407
970026993	343, 376
970028248	529
970028250	24, 163
970029104	141
970029773	516
970031469	344
970031471	345
970032039	167
970032069	22
970034373	112, 113
970034630	399
970034779	413
970034943	396
970036681	382
970037339	400, 401
970037486	314
970037530	401

Altec P/N	Page
970037869	369
970039013	20
970039308	141
970039309	141
970039325	141
970039327	141
970039328	141
970039878	540
970039884	540
970039885	541
970039886	541
970039888	541
970039889	542
970039890	541
970039915	298
970039916	298
970039918	294
970039919	295
970040135	397
970040136	397
970040137	466
970040145	397
970040146	397
970040180	281
970040195	399
970040203	400
970040209	400
970040518	396
970040519	396
970040525	220
970040528	219
970040531	220
970040565	514
970040568	514
970040574	396
970040576	396
970040577	467
970040579	467
970040580	467
970040582	467
970040584	467
970040586	467
970040587	467
970040588	466
970040591	466
970040858	496
970040859	496
970040972	467
970040975	435
970040980	224
970041444	187
970041927	267
970042033	529
970042309	348
970042903	248
970042910	139
970043133	218
970043336	343
970043792	116
970044378	255
970045270	343
970045814	371
970046060	405
970046061	407
970046336	554
970047680	169
970047733	384
970047734	384
970047736	384
970047737	384
970047914	218
970048203	343
970048204	343
970048209	343
970048213	343
970048493	402
970049720	346

Altec P/N	Page
970049723	346
970050099	514, 517, 523
970050659	187
970050838	256
970050843	256
970051684	198-199
970051929	359
970052003	293
970052052	221
970052744	443
970052746	448
970052960	381
970053356	422
970053367	422
970053368	422
970053370	422
970053371	422
970053372	422
970053373	433
970053374	433
970053440	433
970053441	433
970053442	433
970053443	436
970053444	436
970053445	436
970053447	436
970053448	438
970053449	438
970053450	439
970053452	439
970053454	440
970053456	440
970053457	439
970053459	437
970053462	402
970053517	425
970053518	221
970053519	254
970053521	254
970053555	254
970053556	423
970053557	441
970053559	441
970053561	441
970053562	441
970053567	441
9700	

**PRODUCT INDEX
BY ALTEC ITEM NUMBER**

**USA: 1-877-GO ALTEC
(1-877-462-5832)**

www.alteconnect.com

Altec P/N	Page
970053766	441
970053767	439
970053768	439
970053769	439
970053770	433
970054740	51
970054983	305
970055338	518
970055572	349
970055622	467
970055796	291
970055852	256
970055868	256
970055973	553
970056375	151
970056381	151
970056664	343
970057150	544
970057161	305
970057167	293
970057425	253
970057447	343
970057483	528
970058105	51
970058413	433
970059056	208, 464
970059695	344, 345
970059789	268
970060000	218
970060374	292
970060779	536
970060999	268
970062584	347
970062586	347
970062589	347
970062590	347
970062591	347
970062593	347
970062650	347
970062651	347
970062652	347
970062653	347
970062654	347
970062656	347
970062659	347
970062660	347
970062661	347
970062663	347
970062664	347
970062665	347
970062666	347
970062669	347
970062670	347
970062695	218
970063079	343
970063083	347
970063246	528
970063249	528
970063262	344
970063375	29
970064003	159
970064034	522
970064760	374
970065232	307
970065320	157
970066583	162
970066906	305
970066912	403
970067360	349
970067384	43
970067482	553
970067625	552
970067637	381
970068453	173
970068860	405
970069027	283
970069029	401

Altec P/N	Page
970069834	302
970070123	316
970070544	280
970070859	344
970071119	129
970071120	129
970071128	286
970071135	257
970071153	141
970071155	141
970071156	141
970071327	266
970071445	141
970071447	141
970071579	103, 480
970071636	466
970071644	286
970071645	286
970071691	316
970071698	316
970071857	248
970071858	249
970071860	249
970071888	297
970071893	483
970072158	310
970072338	268, 559
970072840	220
970072864	528
970072872	443
970072876	283
970072877	283
970072878	283
970072886	219
970073103	461
970073265	344
970073529	442
970073541	162
970073542	162
970073569	520
970074177	343
970074179	343
970074188	56
970074294	509
970074792	367
970075376	343
970075378	343
970075446	344
970075941	281
970076912	468
970076929	38
970077142	508
970077802	380
970078336	558
970079323	409
970079758	372
970079998	124
970079999	122-123
970080001	125
970080002	125
970080003	125
970080007	125
970080008	480
970080040	313
970080058	442
970080062	442
970080064	442
970080067	442
970080068	313
970080072	313
970080074	313
970080075	313
970080092	480
970080094	480
970080097	480
970080101	480
970080111	309

Altec P/N	Page
970080112	309
970080115	219
970080118	219
970080120	219
970080122	219
970080124	219
970080470	174
970080724	261
970080728	261
970080729	261
970080730	261
970080731	258, 259, 260
970080733	258, 261
970080736	258, 261
970080767	261
970080768	261
970080769	259, 260
970080771	259, 260
970080772	259, 260
970080773	261
970080774	261
970080775	261
970080777	261
970080781	261
970080782	261
970080783	258, 261
970080784	261
970080785	258, 259, 260
970080786	259, 260
970080794	258, 259, 260
970080795	259, 260
970080797	258, 259, 260
970080799	258
970080800	259
970080801	259
970080803	258
970080816	258, 261
970080817	259, 260
970080818	259, 260
970080820	259, 260
970080821	258, 259
970080827	218
970080831	480
970080835	480
970080836	480
970080837	480
970080840	480
970080841	480
970080842	480
970080843	480
970080927	103
970080928	103
970080929	103
970080930	103
970080931	103
970080932	103
970080933	103
970080940	103
970080941	103
970080943	103
970080945	103
970080948	103
970080963	103
970080969	103
970080970	103
970080990	103
970080999	103
970081004	103
970081009	103
970081010	103
970081033	218
970081038	218
970081039	469
970081049	469
970081053	469

Altec P/N	Page
970081055	468
970081056	468
970081058	468
970081059	468
970081061	468
970081062	468
970081065	468
970081109	37
970081291	305
970081317	106
970081325	106
970081329	106
970081331	106
970081333	106
970081334	106
970081337	105
970081340	105
970081625	165
970081627	105
970081629	210
970081631	210
970081632	258
970081634	258, 261
970081966	198-199
970082043	258
970082044	258, 287
970082046	258, 294
970082052	258
970082054	258
970082055	258
970082058	258
970082061	258
970082068	258
970082069	258
970082071	258
970082087	258
970082088	258
970082091	258
970082092	258
970082095	258
970082370	134
970082768	124
970082779	233
970083109	343
970084092	372
970084093	372
970084094	372
970084210	343
970084328	29
970084338	461
970085515	54
970086587	344
970086603	344
970086937	353
970087419	424
970087830	343
970087832	343
970087834	343
970087835	343
970087837	343
970087839	343
970087841	343
970087842	343
970088002	422
970088795	346
970088936	444
970088975	343
970089137	293
970089139	290, 293
970089140	290, 293
970089151	464
970089224	210
970089227	309
970089232	107
970089239	107
970089240	182
970089243	123

Altec P/N	Page
970089245	306
970089247	306
970089411	291
970089413	211
970089414	225
970089415	225
970089473	37
970089474	38
970089478	38
970089527	22, 164
970089530	22, 164
970089541	292
970089626	160
970089628	135
970089629	135
970089630	135
970089632	135
970089633	135
970089634	135
970089635	135
970089641	135
970089642	135
970089651	135
970089653	135
970089655	135
970089685	135
970089696	135
970089705	135
970089872	415
970089931	553
970090213	536
970090219	236
970090221	236
970090222	236
970090223	236
970090224	236
970090225	236
970090227	236
970091061	305
970091296	38
970091298	38
970091300	38
970091308	38
970091310	38, 561
970091311	38, 561
970091312	38, 561
970091313	37
970091316	37
970091478	308
970091548	225
970091562	38
970091563	38
970091641	220
970091801	220
970091804	220
970092015	249
970092102	249
970092171	255
970092173	545
970092396	407
970092607	128, 133
970092610	128, 133
970092825	38
970092826	561
970092828	37
970092829	37
970092830	37
970092831	37
970092832	37
970093070	553
970094042	471
970094051	536
970094961	241
970095151	343
970095162	343
970095171	160
970095674	344

Altec P/N	Page
970095742	167
970095768	442
970096197	554
970096295	107
970096809	544
970097336	51
970097409	468
970097437	198-199
970097816	236
970097916	133
970098040	258
970098041	403
970098043	403
970098044	403
970098046	124, 570
970098047	123
970098051	450
970098209	552
970098349	357
970098528	471
970098529	471
970098530	471
970098531	471
970098532	471
970098533	471
970098588	286
970098589	286
970098590	286
970098592	286
970098595	287
970098597	287
970098598	287
970098600	287
970098602	287
970098617	353
970098618	471
970098619	471
970098621	471
970098622	471
970098626	62
970098631	62
970098638	62
970098646	62
970098649	62
970098663	62
970098667	62
970098669	62
970098670	62
970098672	62
970098673	62
970098674	62
970098712	344
970098727	175
970098786	344
970098786	344
970098788	344
970098789	344
970098803	344
970098804	344
970098806	344
970098807	344
970098808	344
970098810	344
970098812	345
970098813	345
970098979	444
970099032	

PRODUCT INDEX

BY ALTEC ITEM NUMBER

USA: 1-877-GO ALTEC
(1-877-462-5832)

www.alteconnect.com

Altec P/N	Page
970100586	235
970100610	343
970100673	269
970100978	553
970101104	237
970101185	291, 292
970101186	291, 292
970101190	292
970101191	291
970101192	291
970101196	291
970101197	291
970101200	291
970101335	290, 293
970101969	237
970102234	528
970102567	152
970102585	361
970102621	291
970102746	172
970102811	309
970102813	309
970102931	190
970103275	225
970103291	225
970103293	235
970103570	342, 345
970103574	342
970103581	342, 345
970103585	342
970103588	342, 345
970103590	342, 345
970103592	291, 292
970103635	342, 345
970103788	520
970103841	342, 345
970103846	342, 345
970103847	342, 345
970103848	342, 345
970103849	342, 345
970103851	342, 345
970103994	20
970103995	20
970104690	554
970104847	153
970104929	342, 345
970104931	342
970104931	345
970105108	449
970105297	198-199
970105473	218
970105475	343
970105606	302
970105607	302
970105612	303
970106006	374
970106007	374
970106008	374
970106009	374
970106329	271
970106332	468
970106447	544
970106448	553
970106449	553
970106450	553
970106454	553
970106455	553
970106652	421
970106653	421
970106655	421
970106657	421
970106660	421
970106663	421
970106915	24, 162, 446
970107091	344
970107092	344
970107094	344

Altec P/N	Page
970107161	451
970107168	465
970107369	220
970107887	397
970107890	397
970108005	546
970108329	141
970109032	23, 140
970109138	119
970109584	191
970109680	218
970109683	218
970109686	229
970109688	229
970109689	229
970109691	229
970109693	229
970109695	229
970109697	229
970109699	229
970109701	229
970109704	229
970109705	229
970109712	229
970109713	229
970109724	229
970109726	229
970109728	229
970109730	229
970109828	62
970110614	542
970110615	542
970110679	179
970110681	179
970110712	311
970110715	311
970110766	241
970110781	241, 243
970110795	241
970110946	62
970110947	62
970111023	244
970111027	244
970111029	244
970111033	244
970111035	244
970111226	303
970111234	364
970111268	520
970111323	120
970111607	442
970111612	442
970111614	442
970111987	237
970111992	237
970111995	237
970112377	21
970113079	451
970113132	220
970113135	220
970113140	220
970113146	220
970113149	220
970113152	220
970113269	219
970113450	242, 243
970113454	243
970113459	553
970113460	553
970113461	553
970113463	553
970114254	345
970114286	210
970114287	117
970114289	233
970114758	244
970114963	281

Altec P/N	Page
970115170	261
970115171	261
970115172	261
970115173	261
970115174	261
970115175	261
970115176	261
970115177	261
970115178	261
970115325	235
970115609	49
970115899	57
970115903	175
970116257	50
970117232	523
970117684	524
970118121	314
970118243	49
970118311	451
970118415	240
970118418	240
970118420	240
970118425	240
970118428	240
970118429	240
970118434	240
970118440	240
970118442	240
970118454	240
970118455	240
970118457	240
970118458	240
970118460	240
970118462	240
970118541	240
970118543	240
970118544	240
970118597	240
970118598	240
970118599	240
970118600	240
970118607	240
970118611	240
970118613	240
970118724	24, 447
970118754	240
970118759	240
970118761	240
970118762	240
970118765	240
970118773	240
970118774	240
970118842	346
970119305	255
970119522	344
970119978	342
970120109	290
970120237	262
970120318	389
970120725	21
970122728	268, 559
970122731	141
970122871	346
970123853	224
970124704	364
970124923	520
970126170	406
970127407	187
970127524	457
970127533	293
970127681	62
970127686	62
970127995	561
970128002	59
970128502	427
970129486	233
970129493	29

Altec P/N	Page
970129495	456
970130840	342, 345
970130842	342, 345
970130845	342
970131085	560
970131087	558
970131308	552
970131480	210
970131481	185
970131789	305
970131975	374, 375
970132879	403
970133048	156
970133105	389
970133273	141
970133854	20
970134328	51
970134637	410
970134641	129
970134642	22
970134643	22
970134802	127
970134816	257, 464
970134986	132
970135034	82
970135036	82
970135044	389
970135047	389
970135050	389
970135052	389
970135053	389
970135075	389
970135076	389
970135523	49
970135529	49
970135684	132
970135685	132
970135686	132
970136397	305
970136728	49
970136911	374
970136912	374
970136913	374
970136914	374
970136915	374
970136916	374
970136918	374
970136919	374
970136920	374
970136921	374
970136922	374
970136923	374
970136925	374
970136927	374
970136928	374
970136930	294
970137780	369
970138295	541
970138297	471
970139024	382
970141775	225
970141776	225
970141777	225
970141778	225
970141779	225
970141780	225
970141783	225
970141786	575
970141789	575
970141790	575
970141791	22
970141792	22
970145107	48
970146951	342
970148553	344
970148554	344

Altec P/N	Page
970150645	45
970150760	49
970151532	57
970152035	44
970152119	253
970152157	62
970152331	404
970153797	49
970154190	202
970154320	343
970154322	343
970155186	249
970155188	249
970155196	424
970155197	425
970155198	425
970155209	315
970155210	315
970155213	259
970155214	259
970155215	259
970155217	259
970155240	18
970155351	396
970155355	221
970155561	386
970156003	17
970156004	17
970156008	18
970156009	18
970156010	17
970156012	18
970156145	396
970156153	404
970157236	147, 189
970157240	365
970157566	248
970157619	253
970158422	231
970158426	231
970158428	231
970158429	231
970158430	231
970158431	231
970158433	231
970158435	102
970158437	102
970158440	102
970158441	102
970158443	102
970158445	102
970158447	102
970158449	102
970158450	102
970158451	102
970158452	102
970158458	117
970158508	342, 345
970158697	117
970158715	59
970158716	59
970158717	59
970158718	59
970158720	59
970159000	558
970159287	488
970159296	489
970160072	233
970160288	449
970160843	158, 410
970160915	18
970161729	481
970162088	188
970162089	188
970162322	305

Altec P/N	Page
970162323	305
970162775	190
970162864	47
970162914	236
970162915	236
970162916	236
970164173	40
970164174	40
970164176	40
970164179	40
970164362	410
970165365	464
970169607	107
970169618	107
970170619	376
970170620	376
970171688	375
970172709	26
970172711	26
970173878	518
970173948	518
970174430	197
970175155	134
970175507	552
970176191	86
970176847	28
970176848	28
970176849	28
970176850	28
970176851	28
970176852	28
970176855	28
970176856	493
970177636	18
970179315	230
970179343	342, 345
970180326	18
970180483	405
970180636	374
970180809	141
970180889	294
970181322	51
970181780	562
970182160	327
970182172	333
970182174	333
970182175	333
970182177	333
970182179	328
9701	

Altec P/N	Page
970183448	82
970183449	82
970183450	82
970183451	82
970183452	82
970183730	327
970183733	328
970183737	328
970183741	332
970183902	82
970183903	82
970183904	82
970183905	82
970183906	82
970184084	307
970184350	165
970184351	307
970184534	133
970184541	367
970184660	245
970184691	245
970184692	245
970184693	245
970184694	245
970184695	245
970184697	245
970184700	245
970184701	245
970184702	245
970184703	245
970184704	245
970184706	245
970184707	245
970184708	245
970184710	245
970184711	245
970184714	460
970184715	460
970184718	460
970184719	460
970184720	460
970185097	167
970185305	125
970185305	125
970185318	301
970185597	346
970185598	346
970185988	518
970186297	340
970186299	202
970186300	202
970186301	202
970186305	202
970186306	341
970186307	504
970186313	385
970186315	385
970186316	385
970186317	202
970186318	202
970186452	373
970186453	373
970186561	403
970186563	403
970186565	403
970186566	403
970186567	403
970186586	373
970186587	373
970186588	373
970186589	373
970186590	373
970186591	373
970186592	373
970186594	373
970186596	373
970186598	373

Altec P/N	Page
970186599	373
970186600	373
970186601	373
970186621	45
970186675	197
970186730	341
970186731	341
970187379	350
970187380	350
970187381	350
970187382	350
970187383	350
970187384	350
970187404	327
970187581	343
970188912	341
970189044	51
970189221	342, 345
970189363	342, 345
970189364	342, 345
970189941	323
970189942	323
970190442	351
970190767	413
970190903	51
970191068	172
970191135	180
970191223	403
970191672	346
970192302	49
970192362	179
970192885	488
970193162	198-199
970193904	94
970194253	464
970194321	401
970194322	401
970194512	424
970196005	17
970196314	347
970196315	347
970196931	341
970197787	249
970197802	233
970197804	233
970197805	233
970197806	162
970197807	162
970198226	365
970198705	365
970198706	365
970198707	365
970198708	365
970198710	341
970198711	341
970198790	341
970198791	341
970198792	341
970198796	153
970198849	326
970198850	326
970198851	386
970198852	332
970198853	332
970198854	332
970198901	332
970198903	386
970198904	386
970198905	387
970198906	387
970199370	386
970199372	539
970199376	538
970199377	539
970199378	538
970199380	327
970199809	389

Altec P/N	Page
970200091	116
970200479	566
970201065	456
970201067	456
970201144	141
970201146	141
970201147	141
970201148	141
970202670	82
970202671	82
970202864	235
970203368	362
970203505	452, 453
970203577	488
970203579	489
970203582	489
970203768	347
970203838	320
970204236	426
970204285	452, 453
970204510	489
970204511	489
970205741	86
970205742	86
970206056	383
970206097	44
970206491	233
970206888	513
970207169	86
970207457	17
970207898	230
970207899	230
970207900	230
970207901	230
970207902	230
970207903	230
970207904	230
970207905	230
970207906	230
970207907	230
970207908	230
970207910	230
970207911	230
970207912	230
970207913	230
970207914	230
970207915	230
970207916	230
970207917	230
970207919	230
970207920	230
970208088	233
970208091	233
970208092	233
970208451	50
970208462	54
970208468	54, 563
970208484	230
970208517	230
970208525	230
970208539	230
970208544	230
970208546	230
970208548	230
970208561	230
970208565	230
970208572	456
970208575	456
970208576	456
970208579	459
970208581	31, 459
970208582	458
970208590	465
970208915	376
970209163	332
970209164	332
970209165	332

Altec P/N	Page
970209369	151
970210831	344
970211555	107
970211566	105
970211567	105
970211568	105
970211570	105
970211573	105
970211830	136
970211833	450
970211836	450
970211843	451
970211844	451
970211848	451
970211852	459
970211854	459
970211858	459
970211860	452
970211863	452
970211864	452
970211867	452, 453
970211919	120
970212026	452, 453
970212034	452
970212052	453
970212113	353
970212164	575
970212165	575
970212271	110, 572
970212767	175
970213365	248
970214216	359
970215490	404
970215724	143
970215726	143
970216377	369
970216392	383
970216393	29
970216397	116
970216398	116
970216399	320
970216400	320
970216401	320
970216402	362
970216403	364
970216405	364
970216406	364
970216407	364
970216408	364
970216409	364
970216410	364
970216411	364
970216412	364
970216413	364
970216415	364
970216416	364
970216417	494
970216420	495
970216444	495
970216445	495
970216446	495
970216447	496
970216453	496
970216454	496
970216455	496
970216456	496
970216457	496
970216458	496
970216459	496
970216460	496
970216461	496
970216462	496
970216463	496
970216464	496
970216465	496
970216467	496
970216468	496

Altec P/N	Page
970216469	496
970216471	496
970216473	496
970216474	496
970216475	496
970216477	496
970216478	496
970216479	496
970216480	496
970216482	496
970216488	228
970216489	228
970216490	228
970216491	228
970216492	228
970216493	228
970216494	228
970216495	228
970216496	228
970216497	228
970216498	228
970216499	228
970216500	228
970216501	228
970216502	228
970216503	228
970216504	228
970216505	228
970216506	228
970216507	228
970216515	280
970216516	297
970216517	308
970216518	308
970216519	207, 308, 310, 312, 313, 314, 316, 320, 338, 351
970216616	496
970216618	502
970216619	502
970216620	502
970216621	502
970216622	502
970216623	502
970216624	502
970216625	502
970216626	502
970216627	505
970216628	505
970216630	505
970216632	505
970216633	505
970216634	505
970216635	505
970216636	505
970216638	509
970216643	180
970216647	180
970216648	183
970216649	183
970216650	183
970216787	539
970216792	236
970216794	310, 314, 308, 310, 312, 313, 314, 316, 320, 351
970216795	308, 310, 312, 313, 314, 316, 320, 338, 351
970216796	311
970216797	311
970216798	311
970216799	315
970216800	315

Altec P/N	Page
970216801	542
970216802	542
970216803	543
970216804	543
970216805	543
970217109	542
970217110	543
970217111	543
970217666	346
970218542	308
970218574	308
970218575	308
970218576	308
970218577	308
970218578	308
970218581	308
970218582	310
970218584	310
970218585	310
970219891	120
970220062	345
970221229	82
970221230	82
970221231	82
970221685	310
970221781	315
970221783	313
970221784	315
970221785	313
970221868	374
970222175	48
970222638	249
970222689	197
970222691	90
970222851	48
970223516	376
970223517	376
970223518	376
970224829	346
970226183	518
970228911	516
970228968	536
970229424	560
970229438	48
970229439	48
970229440	48
970229441	48
970229442	48
970229443	48
970229450	48
970230074	411
970230075	280
970230078	324
970230577	241
970231115	374
970231	

Altec P/N	Page
970240340	174
970240341	174
970240718	385
970240951	563
970241485	325
970241654	110
970241780	332
970241885	82
970241886	82
970241887	82
970241888	82
970242311	131
970243104	200
970243197	241
970243264	203
970243401	203
970243402	203
970243560	213
970243561	213
970243574	213
970243792	283
970243937	409
970243939	347
970243945	347
970244063	347
970244431	57
970244692	113
970244736	163
970245674	347
970245678	347
970245679	347
970245680	347
970246250	315
970246292	17
970246293	17
970246294	17
970246295	17
970246408	176
970246412	176
970246424	254
970246425	254
970246427	374
970246527	176
970246530	176
970246539	176
970246544	176
970246557	176
970246560	176
970246563	178
970246565	178
970246566	183
970246568	183
970246575	183
970246578	183
970246581	183
970246585	183
970246659	525
970246777	519
970246842	488
970246843	488
970247006	187
970247387	480
970247689	519
970247690	519
970248176	550
970248180	550
970248181	551
970248220	551
970248297	549
970248768	51
970248822	18
970249912	151
970250141	333
970250275	43
970250276	43
970250371	151
970251309	17

Altec P/N	Page
970251315	16
970251318	17
970251325	17
970251763	285
970252237	546
970252499	342, 345
970252501	342, 345
970252503	342, 345
970252504	342, 345
970252507	342, 345
970252509	342, 345
970252512	342, 345
970252513	346
970252516	346
970253205	512
970254148	519
970254149	519
970254150	519
970254260	57
970254292	561
970254647	480
970254648	480
970255662	328
970255738	552
970255772	522
970255943	346
970256213	48
970256911	518
970257015	56
970257150	488
970257671	523
970257872	305
970258504	86
970258602	514
970258853	344
970258993	62
970258994	67
970259003	64
970259005	64
970259007	66
970259653	404
970260757	344
970260792	274
970261111	86
970261116	17
970262793	19
970262822	198-199
970263013	174
970263492	48
970263657	347
970263764	242
970264138	67
970264144	64
970264148	64
970264152	66
970264423	517
970264591	291, 292
970265795	346
970266351	213
970266352	213
970266355	213
970266356	213
970266357	213
970266368	213
970266465	209
970266779	101
970266780	101
970266781	101
970266782	101
970267016	328
970267092	405
970267350	346
970267657	201
970267921	17
970267923	16
970267986	201
970267996	200

Altec P/N	Page
970268548	102
970268551	102
970269010	279
970269014	279
970269647	63
970269658	489
970269756	303
970270709	151
970270789	522
970271340	17
970271341	17
970271343	16
970272444	374
970272495	22
970272507	22
970272509	22
970272510	22
970272814	90
970274147	64
970274210	411
970274857	282
970274860	282
970274916	17
970275089	343
970277098	45
970277099	45
970277131	206
970277792	345, 346
970277802	346
970277808	346
970278539	33
970278540	32, 34
970278851	38
970279136	327
970279459	347
970279462	347
970279467	347
970279737	552, 553
970279738	552, 553
970280266	547, 554
970280711	343
970280714	343
970280715	343
970280717	325
970280966	346
970280967	346
970280970	346
970281083	86
970281879	167
970282200	343
970282344	343
970282625	17
970282631	17
970282632	17
970282633	346
970282635	346
970282833	174
970283351	281
970283761	18
970284417	21
970284500	457
970284690	18
970284729	516
970284975	281
970285635	179
970285637	179
970285762	524
970286800	146
970286894	198-199
970287546	63
970287605	65
970287609	66
970287632	491
970288008	347
970288015	413
970288397	316, 351
970288620	79

Altec P/N	Page
970288621	79
970288622	79
970288623	79
970288718	343
970288947	101, 559
970288952	101, 559
970289089	67
970289097	65
970289116	121
970289118	119, 559
970289120	119
970289121	121
970289122	121
970289711	308
970290038	376
970290180	189
970290208	121
970290555	176
970291056	191
970291124	554
970291325	24, 163, 446
970291338	179
970291342	179
970291519	343
970291544	518
970291835	327
970292405	344
970292526	474
970292984	560
970292987	561
970293019	151
970293118	346
970293121	48
970294017	147
970294018	147
970294019	147
970294235	198-199
970294264	151
970294631	41-43
970294635	42
970294637	42
970294760	347
970294923	366
970294936	367
970295623	197
970295633	197
970296411	197
970296867	197
970297519	257
970297815	546
970298011	321
970298014	321
970298022	363
970298039	363
970298041	363
970298043	363
970298044	363
970298045	363
970298047	363
970298048	363
970298580	346
970298615	49
970299002	48
970299160	276
970299161	276
970299181	350
970299183	350
970299185	350
970299187	350
970299246	347
970299671	17
970299675	17
970299679	18
970299717	550
970300463	518
970300876	340
970302068	410

Altec P/N	Page
970302332	342, 345
970302334	342, 345
970302556	404
970302574	287
970302770	324
970303209	49
970303214	49
970303215	49
970304492	249
970304563	132
970305399	346
970305482	16
970305483	16
970305484	16
970306545	82
970307118	139
970307899	343
970307906	343
970307912	343
970307916	343
970307920	343
970307921	343
970307922	343
970308028	547
970308038	393
970308121	17
970308570	378
970309393	200
970309641	551
970309737	49
970310802	518
970311171	274
970311173	274
970312216	47
970312224	32, 34
970312227	33, 34
970312497	147
970313253	512
970313573	17
970313575	17
970313576	17
970313577	17
970313578	17
970314266	82
970314477	72
970314478	73
970314479	73
970314480	73
970314481	73
970314482	73
970314483	73
970314484	73
970314485	73
970314486	73
970314487	73
970314488	73
970314489	73
970314490	73
970314491	73
970314492	73
970314493	73
970314494	73
970314495	73
970314496	73
970314497	73
970314498	73
970314507	76
970314508	76
970314509	76
970314510	76
970314511	76
970314512	76
970315663	47
970317528	346
970318050	86
970318143	347

Altec P/N	Page
970320098	146
970320676	121
970320939	281
970321033	546
970321812	547, 554
970321837	126
970321843	126
970321844	126
970321846	320
970322062	206
970322650	395
970322718	156
970323033	49
970323555	49
970323921	467
970324176	282
970324177	282
970324178	282
970324203	269
970324510	206
970324726	23, 140
970324815	346
970324821	346
970324831	346
970324836	346
970325356	42
970325359	41-43
970325361	42
970325362	42
970325363	42
970325364	42
970325365	42
970325371	42
970325373	42
970325374	42
970325376	42
970325377	42
970325379	42
970325380	42
970325381	42
970325382	42
970325383	42
970325386	41
970325387	41
970325388	41
970325390	41
970325392	44
970325394	44
970325395	44
970325464	347
970325468	347
970325470	347

PRODUCT INDEX
BY ALTEC ITEM NUMBER

USA: 1-877-GO ALTEC
(1-877-462-5832)

www.alteconnect.com

Altec P/N	Page	Altec P/N	Page	Altec P/N	Page	Altec P/N	Page	Altec P/N	Page	Altec P/N	Page
970329433	73	970331461	73	970335038	544	970344509	343	970345946	64	970346023	64
970329434	73	970331462	73	970335053	127, 573	970344625	226	970345947	64	970346024	64
970329436	73	970331463	73	970335300	454	970345200	342, 345	970345948	64	970346025	64
970329437	73	970331464	73	970335302	454	970345201	342, 345	970345949	64	970346026	64
970329438	73	970331465	73	970335303	454	970345705	226	970345950	64	970346027	64
970329440	73	970331466	73	970335304	454	970345789	63	970345951	64	970346028	64
970329442	73	970331467	73	970335305	454	970345790	63	970345952	64	970346029	64
970329444	73	970331468	73	970335306	454	970345791	63	970345953	64	970346030	64
970329578	348	970331469	73	970335307	454	970345792	63	970345954	64	970346031	64
970329580	348	970331470	73	970335308	454	970345793	63	970345955	64	970346032	64
970329657	76	970331471	73	970335309	454	970345794	63	970345956	64	970346033	64
970329658	76	970331472	73	970335310	454	970345795	63	970345957	64	970346034	64
970329659	76	970331473	73	970335311	454	970345796	63	970345958	64	970346035	67
970329660	76	970331474	73	970335312	454	970345797	63	970345959	64	970346036	67
970329661	76	970331475	73	970335313	454	970345798	63	970345960	64	970346037	67
970329662	76	970331477	73	970335314	454	970345799	63	970345961	64	970346038	67
970329767	147, 189	970331478	73	970335315	454	970345800	63	970345962	64	970346039	67
970329799	48	970331479	73	970335316	454	970345801	63	970345963	64	970346040	67
970329803	48	970331480	73	970335318	455	970345802	63	970345964	64	970346041	67
970329813	539	970331481	73	970335319	455	970345803	63	970345965	64	970346042	67
970329870	265	970331482	73	970335320	455	970345804	63	970345966	64	970346043	67
970329889	265	970331483	73	970335321	455	970345813	63	970345967	64	970346044	67
970330033	267	970331484	73	970335322	455	970345814	63	970345968	64	970346045	67
970330034	267	970331485	73	970335323	455	970345815	63	970345969	64	970346046	67
970330038	300	970331486	73	970335324	455	970345816	63	970345970	64	970346047	67
970330473	268, 559	970331487	73	970335325	455	970345817	63	970345971	64	970346048	67
970330719	82	970331488	73	970335327	453	970345818	63	970345972	64	970346049	66
970330722	82	970331489	73	970335328	453, 454	970345819	63	970345973	64	970346050	66
970330724	82	970331490	73	970335329	452, 453	970345820	63	970345974	64	970346051	66
970330725	82	970331492	73	970335330	454	970345821	62	970345975	64	970346052	66
970331341	76	970331493	73	970335331	454	970345822	62	970345976	64	970346053	66
970331342	76	970331494	73	970335332	454	970345823	62	970345977	64	970346054	66
970331343	76	970331495	73	970335337	455	970345824	62	970345978	64	970346055	66
970331344	76	970331496	73	970335339	457	970345826	62	970345979	64	970346056	66
970331345	76	970331497	73	970335344	136, 465	970345827	62	970345980	64	970346057	66
970331346	76	970331498	73	970335345	136, 465	970345828	62	970345981	64	970346058	66
970331366	73	970331499	73	970335346	31	970345829	62	970345982	64	970346059	66
970331367	73	970331500	73	970335350	491	970345830	62	970345983	64	970346083	66
970331368	73	970331501	73	970335351	457	970345831	62	970345984	64	970346084	66
970331369	73	970331502	73	970335352	457	970345832	62	970345985	64	970346085	66
970331370	73	970331503	73	970335353	457	970345833	62	970345986	64	970346086	66
970331371	73	970331504	73	970335354	457	970345834	62	970345987	64	970346087	66
970331372	73	970331506	73	970335355	537	970345835	62	970345988	64	970346088	66
970331373	73	970331507	73	970335356	537	970345836	62	970345989	64	970346089	66
970331374	73	970331508	73	970335357	537	970345837	62	970345990	64	970346090	66
970331375	73	970331509	73	970335358	537	970345838	62	970345991	64	970346091	66
970331376	73	970331510	73	970335359	537	970345839	62	970345992	64	970346092	66
970331377	73	970331734	378	970335360	537	970345840	62	970345993	64	970346093	66
970331378	73	970331737	82	970335361	537	970345841	62	970345994	64	970346117	66
970331379	73	970332337	197	970335362	537	970345842	62	970345995	64	970346118	66
970331381	73	970332342	197	970335363	537	970345843	62	970345996	64	970346119	66
970331383	73	970332343	197	970335364	537	970345847	62	970345997	64	970346120	66
970331384	73	970332350	197	970335365	537	970345851	62	970345998	64	970346121	66
970331387	73	970332352	197	970335366	537	970345852	62	970345999	64	970346122	66
970331388	73	970332362	197	970335424	516	970345853	62	970346000	64	970346123	66
970331390	73	970332365	197	970335503	206	970345854	62	970346001	64	970346124	66
970331393	73	970332368	197	970336290	343	970345855	62	970346002	64	970346125	66
970331394	73	970332372	197	970336531	198-199	970345926	64	970346003	64	970346126	66
970331437	73	970332374	197	970336938	320	970345927	64	970346004	64	970346127	66
970331438	73	970332376	197	970337945	344	970345928	64	970346005	64	970346128	66
970331439	73	970333316	122	970339650	90	970345929	64	970346006	64	970346153	66
970331440	73	970333356	447	970339965	188	970345930	64	970346007	64	970346154	66
970331441	73	970333359	447	970339969	188	970345931	64	970346008	64	970346155	66
970331442	73	970333765	257	970341078	290	970345932	64	970346009	64	970346156	66
970331443	73	970333786	22	970341605	90	970345933	64	970346010	64	970346157	66
970331444	73	970333787	22	970341959	63	970345934	64	970346011	64	970346158	66
970331445	73	970334123	507	970341975	63	970345935	64	970346012	64	970346159	66
970331447	73	970334130	506	970341985	63	970345936	64	970346013	64	970346160	66
970331450	73	970334131	507	970341992	66	970345937	64	970346014	64	970346161	66
970331452	73	970334166	506	970342350	546	970345938	64	970346015	64	970346178	63
970331453	73	970334171	506	970342354	546	970345939	64	970346016	64	970346179	63
970331454	73	970334174	506	970342450	326	970345940	64	970346017	64	970346180	63
970331456	73	970334177	507	970342629	195	970345941	64	970346018	64	970346181	63
970331457	73	970334209	506	970342646	47	970345942	64	970346019	64	970346182	63
970331458	73	970334212	507	970343942	332	970345943	64	970346020	64	970346183	63
970331459	73	970334219	507	970344255	344	970345944	64	970346021	64	970346184	63
970331460	73	970334379	516	970344256	344	970345945	64	970346022	64	970346185	63



PRODUCT INDEX

BY ALTEC ITEM NUMBER

USA: 1-877-GO ALTEC
(1-877-462-5832)

www.alteccconnect.com

Altec P/N	Page
970346186	67
970346187	67
970346188	67
970346189	67
970346190	67
970346191	67
970346192	67
970346210	63
970346211	63
970346212	63
970346213	63
970346214	63
970346215	63
970346216	63
970346217	63
970346218	63
970346219	63
970346220	63
970346221	63
970346222	63
970346223	63
970346224	63
970346225	63
970346226	63
970346227	63
970346228	63
970346229	63
970346230	63
970346231	63
970346232	63
970346233	63
970346234	63
970346235	63
970346236	63
970346237	63
970346238	63
970346239	63
970346240	63
970346241	63
970346242	63
970346243	63
970346244	63
970346245	63
970346246	63
970346247	63
970346248	63
970346249	63
970346250	63
970346251	63
970346252	63
970346253	63
970346262	65
970346263	65
970346264	65
970346265	65
970346266	65
970346267	65
970346268	65
970346269	65
970346270	65
970346271	65
970346272	65
970346273	65
970346274	65
970346275	65
970346276	65
970346277	65
970346278	65
970346279	65
970346280	65
970346281	65
970346282	65
970346283	65
970346284	65
970346285	65
970346286	65
970346287	65

Altec P/N	Page
970346288	65
970346289	65
970346290	65
970346291	65
970346292	65
970346293	65
970346294	65
970346295	65
970346296	65
970346297	65
970346298	65
970346299	65
970346300	65
970346301	65
970346302	65
970346303	65
970346304	65
970346305	65
970346306	65
970346307	65
970346308	65
970346309	65
970346310	65
970346311	65
970346312	65
970346313	65
970346314	65
970346315	65
970346316	65
970346317	65
970346318	65
970346319	65
970346320	65
970346321	65
970346322	65
970346323	65
970346324	65
970346325	65
970346326	65
970346327	65
970346328	65
970346329	65
970346330	65
970346364	77
970346365	77
970346366	77
970346367	77
970346368	77
970346369	77
970346370	77
970346371	77
970346372	77
970346373	77
970346374	77
970346375	77
970346380	77
970346381	77
970346382	77
970346383	77
970346400	79
970346401	79
970346402	79
970346403	79
970346404	79
970346405	79
970346406	79
970346407	79
970346456	81
970346457	81
970346458	81
970346459	81
970346460	81
970346461	81
970346462	81
970346463	81
970346464	81
970346465	81

Altec P/N	Page
970346466	81
970346467	81
970346468	81
970346469	81
970346470	81
970346471	81
970346472	81
970346473	81
970346474	81
970346475	81
970346476	81
970346477	81
970346478	81
970346479	81
970346480	80
970346481	80
970346482	80
970346483	80
970346484	80
970346485	80
970346486	80
970346487	80
970346488	80
970346489	80
970346490	80
970346491	80
970346492	80
970346493	80
970346494	80
970346495	80
970346496	80
970346497	80
970346498	80
970346499	80
970346500	80
970346501	80
970346502	80
970346503	80
970346504	80
970346505	80
970346506	80
970346507	80
970346508	80
970346509	80
970346510	80
970346511	80
970346512	80
970346513	80
970346514	80
970346515	80
970346516	80
970346517	80
970346518	80
970346586	96
970346587	96
970346588	96
970346589	96
970346590	96
970346591	96
970346592	96
970346593	96
970346594	96
970346595	96
970346596	96
970346597	96
970346604	96
970346605	96
970346606	96
970346607	96
970346608	96
970346609	96
970346610	96
970346611	96
970346612	96
970346613	96
970346614	96
970346615	96

Altec P/N	Page
970346622	178
970346623	178
970346631	184
970346632	184
970346635	389
970346636	389
970346638	206
970346639	206
970346640	206
970346641	206
970346642	206
970346643	206
970346650	120
970346654	188
970346655	188
970346659	189
970346660	159
970346665	193, 195
970346666	193, 195
970346669	196
970346684	62
970347075	226
970347076	226
970347081	256
970347280	461
970347486	126
970347487	126
970347488	126
970348322	347
970348641	255
970348647	255
970348648	255
970348649	255
970348658	47
970349028	17
970349826	90
970350249	32, 34
970350250	82
970350323	82, 342, 345
970351047	277
970351049	277
970351050	277
970351051	277
970351052	277
970351055	277
970351058	277
970351059	277
970351060	277
970351063	277
970351066	277
970351105	415
970351135	276
970351136	276
970351139	276
970351140	278
970351239	325
970351244	322
970351273	322
970351278	386
970351280	386
970351281	386
970351292	387
970351294	416
970351352	60
970351525	416
970351528	416
970351621	143
970351626	143
970351811	323
970351823	327
970351826	325
970351837	322
970351842	322
970351844	328
970352163	328
970353135	126
970353164	56

Altec P/N	Page
970353165	256
970353767	378
970353806	378
970353862	378
970353869	82
970354254	33, 34
970354345	366
970354354	366
970354356	366
970354364	113
970354599	237
970354601	237
970354602	237
970354603	237
970354604	237
970354901	314
970354904	314
970354965	529
970354967	529
970354970	529
970354975	529
970354980	529
970355069	517
970355144	36
970355488	332
970355511	278
970355515	322
970355516	322
970355528	322
970355530	322
970355933	19
970355944	17
970355955	17
970355964	17
970355975	17
970355978	17
970355982	17
970355985	17
970356391	17
970356394	17
970356396	17
970356400	17
970356907	153
970356912	17
970356925	17
970356928	17
970356939	17
970356953	17
970356956	17
970356977	17
970356978	17
970357032	524
970357286	203
970357654	49
970357667	49
970357677	49
970357691	49
970357694	49
970357697	47
970357700	360
970357707	47
970357716	47
970357722	47
970357725	47
970357749	47
970357763	47
970357766	47
970357771	47
970357775	55
970357777	55
970357782	55
970357786	55
970357788	340
970357792	340
970358352	47
970358374	47
970358385	47

Altec P/N	Page
970358388	47
970358409	47
970358413	49
970358436	49
970358437	49
970358440	49
970358452	50
970358455	50
970358605	57
970358608	57
970358630	57
970358637	320
970358645	321
970358652	321
970358660	321
970358665	364
970358666	303
970358669	303
970358673	303
970358729	517
970358793	414
970359275	517
970359281	517
970359383	151
970359384	151
970359385	151
970359386	151
970359387	151
970359388	151
970359389	151
970359391	151
970359392	151
970359394	151
970359395	151
970359396	151
970359397	151
970359398	151
970359399	151
970359400	151
970359401	151
970359402	151
970359403	151
970359404	151
970359407	151
970359408	151
970359410	151
970359412	151
970359413	151
970359414	151
970359415	151
970359416	151
970359417	151
970359418	151
970359419	151
970359420	151
970359421	151
970359422	151
970359423	151
970359424	151
970359425	151
970359	

Altec P/N	Page
970359520	32
970359521	32-35
970359527	32, 34
970359534	32
970359539	33
970359544	33
970359546	33
970359548	33
970359552	33, 34
970359554	33, 34
970359560	33
970359562	33
970359565	33
970359846	36
970359853	36
970359854	36
970359856	36
970361502	326
970361570	491
970361775	407
970361864	191
970361888	40
970361912	40
970361914	40
970361916	57
970361919	36, 560
970361920	36
970361941	370
970362037	74
970362653	538
970362973	538
970363092	45
970363093	45
970363117	45
970363128	45
970363129	45
970363180	322
970363181	322
970363182	322
970363719	451
970363839	188
970363902	523, 525
970363905	519, 523
970363920	519, 524
970364226	256
970364229	256
970364609	160
970364780	342
970364786	342
970364791	342
970364795	342, 345
970364809	342
970364814	342, 345
970364817	342, 345
970364921	142
970364948	74
970365010	201
970365049	514, 517, 525
970365399	344
970366079	74
970366080	74
970366081	74
970366082	74
970366083	74
970366084	74
970366085	74
970366086	74
970366087	74
970366088	74
970366089	74
970366090	74
970366091	74
970366092	74
970366093	74
970366094	74
970366095	74
970366096	74

Altec P/N	Page
970366097	74
970366098	74
970366099	74
970366100	74
970366101	74
970366102	74
970366103	74
970366104	74
970366105	74
970366106	74
970366107	74
970366108	74
970366109	74
970366110	74
970366111	74
970366112	74
970366113	74
970366114	74
970366115	74
970366116	74
970366117	74
970366118	74
970366119	74
970366120	74
970366121	74
970366122	74
970366123	74
970366124	74
970366125	74
970366126	74
970366127	74
970366128	74
970366129	74
970366130	74
970366131	74
970366132	74
970366133	74
970366134	74
970366135	74
970366136	74
970366137	74
970366138	74
970366139	74
970366140	74
970366141	74
970366142	74
970366143	74
970366144	74
970366145	74
970366146	74
970366147	74
970366148	74
970366149	74
970366150	74
970366151	74
970366152	74
970366154	74
970366155	74
970366156	74
970366157	74
970366158	74
970366159	74
970366160	74
970366161	74
970366162	74
970366163	74
970366165	74
970366166	74
970366167	74
970366168	74
970366169	74
970366170	74
970366171	74
970366172	74
970366173	74
970366175	74
970366176	74

Altec P/N	Page
970366177	74
970366178	74
970366179	74
970366180	74
970366181	74
970366182	74
970366183	74
970366184	74
970366185	74
970366186	74
970366187	74
970366188	74
970366189	74
970366190	74
970366191	74
970366192	74
970366193	74
970366194	74
970366195	74
970366196	74
970366197	74
970366198	74
970366199	74
970366200	74
970366201	74
970366202	74
970366203	74
970366204	74
970366205	74
970366206	74
970366207	74
970366208	74
970366212	82
970366218	82
970366219	82
970366220	82
970366221	82
970366227	82
970366228	82
970366229	82
970366234	82
970366235	82
970366236	82
970366237	82
970366238	82
970366239	82
970366240	82
970366241	82
970366242	82
970366243	82
970366244	82
970366245	82
970366246	82
970366247	82
970366248	82
970366249	82
970366250	82
970366251	83
970366252	83
970366253	83
970366254	83
970366255	83
970366256	83
970366257	83
970366258	82-83
970366259	83
970366260	83
970366261	83
970366262	83
970366263	83
970366264	83
970366265	83
970366266	83
970366267	83
970366268	83
970366269	83
970366270	83

Altec P/N	Page
970366271	83
970366272	83
970366273	83
970366274	83
970366275	83
970366276	83
970366277	83
970366278	83
970366279	83
970366280	83
970366281	83
970366282	83
970366283	83
970366284	83
970366285	83
970366286	83
970366287	83
970366288	83
970366289	83
970366290	83
970366291	83
970366292	83
970366293	83
970366294	83
970366295	83
970366296	83
970366297	83
970366298	83
970366317	280
970366318	280
970366319	280
970366320	280
970366321	280
970366322	280
970366324	281
970366325	281
970366326	281
970366327	281
970366328	281
970366329	281
970366330	281
970366331	281
970366332	281
970366333	281
970366334	281
970366335	281
970366336	281
970366337	281
970366338	281
970366339	281
970366340	281
970366341	281
970366342	281
970366343	281
970366344	281
970366345	252
970366346	252
970366347	252
970366348	252
970366349	252
970366350	252
970366351	252
970366352	252
970366353	252
970366354	252
970366355	252
970366356	252
970366357	252
970366358	252
970366359	252
970366360	226
970366361	226
970366362	226
970366363	226
970366364	226
970366365	226
970366366	226

Altec P/N	Page
970366367	226
970366368	226
970366369	226
970366370	226
970366371	226
970366372	226
970366373	226
970366374	226
970366375	226
970366376	227
970366377	227
970366378	227
970366379	227
970366380	227
970366381	227
970366382	227
970366383	227
970366384	200
970366385	200
970366386	201
970366388	201
970366389	201
970366390	201
970366391	201
970366392	75
970366393	75
970366394	75
970366395	75
970366396	75
970366397	75
970366398	75
970366399	75
970366400	75
970366401	75
970366402	75
970366403	75
970366405	487
970366406	487
970366407	487
970366410	487
970366411	487
970366412	487
970366415	487
970366416	487
970366417	487
970366420	487
970366421	487
970366422	487
970366425	487
970366426	487
970366427	487
970366430	487
970366431	487
970366432	487
970366434	342, 345
970366435	342, 345
970366436	342, 345
970366437	342, 345
970366438	342, 345
970366439	342, 345
970366440	342, 345
970366441	342, 345
970366442	342, 345
970366443	342, 345
970366444	342, 345
970366445	342, 345
970366446	342, 345
970366447	342, 345
970366448	342, 345
970366449	342, 345
970366450	342, 345
970366451	342, 345
970366452	342, 345
970366453	342, 345
970366454	342, 345
970366455	342
970366457	342, 345

Altec P/N	Page
970366458	342, 345
970366460	343
970366461	343
970366462	343
970366463	343
970366464	343
970366465	343
970366466	343
970366467	343
970366468	343
970366469	343
970366470	343
970366471	343
970366472	343
970366473	343
970366474	343
970366475	343
970366476	343
970366477	343
970366478	343
970366479	343
970366480	343
970366481	343
970366482	343
970366483	343
970366484	343
970366485	343
970366486	343
970366488	343
970366489	343
970366490	343
970366491	343
970366492	343
970366493	343
970366494	343
970366495	343
970366496	343
970366497	343
970366498	343
970366499	343
970366500	343
970366501	343
970366502	343
970366503	343
970366504	343
970366505	343
970366506	343
970366507	343
970366508	343
970366509	343
970366510	343
970366511	343
970366512	343

Altec P/N	Page	Altec P/N	Page	Altec P/N	Page	Altec P/N	Page	Altec P/N	Page	Altec P/N	Page
970366536	344	970366613	342	970366691	347	970375144	16	970398259	145	970400135	90
970366537	344	970366615	345	970366692	347	970375145	16	970398260	144, 146	970400136	90
970366538	344	970366616	345	970366693	347	970376106	34	970398262	146	970400137	90
970366539	344	970366617	346	970366694	347	970377041	168	970398263	146	970400138	90
970366540	344	970366618	346	970366695	347	970377682	262	970398459	324	970400139	90
970366541	344	970366619	346	970366696	347	970377970	114	970400060	393	970400140	90
970366542	344	970366620	346	970366697	347	970380209	389	970400061	393	970400141	90
970366543	344	970366621	346	970366698	347	970380210	389	970400065	86	970400142	90
970366544	344	970366622	346	970366699	347	970380673	290	970400066	86	970400143	90
970366545	344	970366623	346	970366700	347	970381459	178	970400067	86	970400144	90
970366546	344	970366624	346	970366701	347	970381461	178	970400068	86	970400145	90
970366547	344	970366625	346	970366702	347	970381466	178	970400069	86	970400146	90
970366548	344	970366626	346	970366703	347	970381469	178	970400070	86	970400147	90
970366549	344	970366627	346	970366704	347	970381474	178	970400071	86	970400148	90
970366550	344	970366628	346	970366705	347	970381475	178	970400072	86	970400149	90
970366551	344	970366629	346	970366706	347	970381918	380	970400073	86	970400150	90
970366552	344	970366630	346	970366707	347	970385284	114	970400074	86	970400151	90
970366553	344	970366631	346	970366708	347	970385332	114	970400075	86	970400152	90
970366554	344	970366632	346	970366709	347	970385340	114	970400076	86	970400153	90
970366555	344	970366633	346	970366710	347	970385345	114	970400077	86	970400154	90
970366556	344	970366634	346	970366711	347	970385346	115	970400078	86	970400155	90
970366557	344	970366635	346	970366712	347	970385348	115	970400079	86	970400156	90
970366558	344	970366636	346	970366713	347	970385350	115	970400080	86	970400157	90
970366559	344	970366637	346	970366714	347	970385351	115	970400081	86	970400158	90
970366560	344	970366638	346	970366715	347	970385383	115	970400082	86	970400159	90
970366561	344	970366639	346	970366716	347	970387524	226	970400083	86	970400160	90
970366562	344	970366640	346	970366717	347	970388639	34	970400084	86	970400161	90
970366563	344	970366641	346	970366718	347	970388640	34	970400085	86	970400162	90
970366564	344	970366642	346	970366719	347	970388642	34	970400086	86	970400163	90
970366565	344	970366643	346	970366720	347	970388645	34	970400087	86	970400164	90
970366566	344	970366644	346	970366721	347	970389013	34	970400088	86	970400165	91
970366567	344	970366645	346	970366722	347	970389126	152	970400089	86	970400166	91
970366568	344	970366646	346	970366723	347	970389356	536	970400090	86	970400167	91
970366569	344	970366647	346	970366724	347	970389357	226	970400091	86	970400168	91
970366570	344	970366648	346	970366725	347	970389358	226	970400092	86	970400169	91
970366571	344	970366649	346	970366726	347	970389359	226	970400093	86	970400170	91
970366572	344	970366650	346	970366727	347	970389362	190	970400094	86	970400171	91
970366573	344	970366651	346	970366728	347	970389446	191	970400095	86	970400172	91
970366574	344	970366652	346	970366729	347	970389625	168	970400096	86	970400173	91
970366575	344	970366653	346	970366730	347	970389692	364	970400097	86	970400174	91
970366576	345	970366654	346	970366731	347	970389693	364	970400098	86	970400175	91
970366577	345	970366655	346	970366732	347	970389705	320	970400099	86	970400176	91
970366578	345	970366656	346	970366733	347	970389707	320	970400100	86	970400177	91
970366579	345	970366657	346	970366734	347	970389708	320	970400101	86	970400178	91
970366580	345	970366658	346	970366735	347	970389709	320	970400102	86	970400179	91
970366582	345	970366659	346	970366736	347	970390494	320	970400103	86	970400180	91
970366583	344	970366660	346	970366737	347	970390793	351	970400104	86	970400181	91
970366584	344	970366661	347	970366738	347	970390794	351	970400105	86	970400182	91
970366585	344	970366662	347	970366739	347	970392450	187	970400106	86	970400183	91
970366586	344	970366663	347	970366740	347	970392461	187	970400107	86	970400184	91
970366587	344	970366664	347	970366741	347	970392464	169, 189	970400108	86	970400185	91
970366588	344	970366665	347	970366742	347	970392466	169, 189	970400109	86	970400186	91
970366589	344	970366666	347	970366743	347	970392467	169, 189	970400110	86	970400187	91
970366590	344	970366667	347	970366744	347	970392468	169, 189	970400111	86	970400188	91
970366591	344	970366668	347	970366745	347	970392469	169, 189	970400112	86	970400189	89
970366592	344	970366669	347	970366746	347	970392470	169, 189	970400113	86	970400190	89
970366593	344	970366670	347	970366747	347	970392815	187	970400114	90	970400191	89
970366594	344	970366671	347	970366748	347	970392817	187	970400115	90	970400192	89
970366595	344	970366672	347	970366749	347	970393307	420	970400116	90	970400193	89
970366596	344	970366673	347	970366750	347	970393314	420	970400117	90	970400194	89
970366597	344	970366674	347	970368831	285	970393319	420	970400118	90	970400195	89
970366598	344	970366675	347	970369602	34	970394460	523	970400119	90	970400196	89
970366599	344	970366676	347	970369604	34	970395851	90	970400120	90	970400197	89
970366600	344	970366677	347	970369730	524	970398242	334	970400121	90	970400198	89
970366601	344	970366678	347	970369804	343	970398243	334	970400122	90	970400199	89
970366602	344	970366679	347	970373152	290	970398244	336	970400123	90	970400200	89
970366603	345	970366680	347	970374980	18	970398245	336	970400124	90	970400201	89
970366604	345	970366681	347	970374997	18	970398246	337	970400125	90	970400202	89
970366605	345	970366682	347	970375006	18	970398247	337	970400126	90	970400203	89
970366606	345	970366683	347	970375007	18	970398248	338	970400127	90	970400204	89
970366607	345	970366684	347	970375012	18	970398249	336	970400128	90	970400205	89
970366608	345	970366685	347	970375019	18	970398250	336	970400129	90	970400206	89
970366609	345	970366686	347	970375026	18	970398254	145	970400130	90	970400207	89
970366610	345	970366687	347	970375140	16	970398255	145	970400131	90	970400208	89
970366611	345	970366688	347	970375141	16	970398256	145	970400132	90	970400209	89
970366612	345	970366689	347	970375142	16	970398257	145	970400133	90	970400210	89
970366613	345	970366690	347	970375143	16	970398258	145	970400134	90	970400211	89

Altec P/N	Page
970400212	89
970400213	89
970400214	89
970400215	89
970400216	88
970400217	88
970400218	88
970400219	88
970400220	88
970400221	88
970400222	88
970400223	88
970400224	88
970400225	88
970400226	88
970400227	88
970400228	88
970400231	88
970400232	88
970400233	88
970400234	88
970400235	88
970400236	88
970400237	88
970400238	88
970400239	88
970400240	88
970400241	88
970400242	88
970400243	88
970400244	88
970400245	88
970400246	88
970400247	88
970400248	88
970400249	88
970400250	88
970400251	88
970400252	88
970400253	88
970400256	88
970400257	88
970400258	88
970400259	88
970400260	88
970400261	88
970400262	88
970400263	88
970400264	88
970400265	88
970400266	89
970400267	89
970400268	89
970400269	89
970400270	89
970400271	89
970400272	89
970400273	89
970400274	89
970400275	89
970400276	89
970400277	89
970400278	89
970400279	89
970400280	89
970400281	89
970400282	89
970400283	89
970400284	89
970400285	89
970400286	89
970400287	89
970400288	89
970400289	89
970400290	87
970400291	87
970400292	87

Altec P/N	Page
970400293	87
970400294	87
970400295	87
970400296	87
970400297	87
970400298	87
970400299	87
970400300	87
970400303	87
970400304	87
970400305	87
970400306	87
970400307	87
970400308	87
970400309	87
970400310	87
970400311	87
970400312	87
970400313	87
970400314	87
970400315	87
970400316	87
970400317	87
970400318	87
970400319	87
970400320	87
970400321	87
970400322	87
970400323	87
970400324	87
970400327	87
970400328	87
970400329	87
970400330	87
970400331	87
970400332	87
970400333	87
970400334	87
970400335	87
970400336	87
970400339	351
970400340	351
970400341	351
970400342	316, 351
970400343	316, 351
970400344	316, 351
970400345	316, 351
970400346	316, 351
970400352	316, 351
970400353	316, 351
970400354	316, 351
970400355	316
970400356	351
970400357	351
970400359	351
970400361	312, 351
970400363	351
970400364	351
970400365	351
970400366	312
970400367	312
970400368	312
970400369	312
970400370	312
970400371	312
970400372	312
970400377	312
970400379	352
970400380	352
970400381	352
970400382	352
970400383	352
970400384	352
970400385	352
970400386	352
970400387	352
970400388	352

Altec P/N	Page
970400389	352
970400390	352
970400391	352
970400392	352
970400393	352
970400394	352
970400395	352
970400396	352
970400397	352
970400398	352
970401503	547
970402150	256
970402151	256
970403377	514
970405422	524
970405501	546
970405869	92
970405870	92
970405871	92
970405872	92
970405873	92
970405874	92
970405875	92
970405876	92
970405877	92
970405878	92
970405879	92
970405880	92
970405881	92
970405882	92
970405883	92
970405884	92
970405885	92
970405886	92
970405887	92
970405888	92
970405889	92
970405890	92
970405891	92
970405892	92
970405893	92
970405894	92
970405895	92
970405896	92
970405897	92
970405898	92
970405899	92
970405900	92
970405901	92
970405902	92
970405903	92
970405904	92
970405905	92
970405906	92
970405907	92
970405908	92
970405909	93
970405910	93
970405911	93
970405912	93
970405913	93
970405914	93
970405915	93
970405916	93
970405917	93
970405918	93
970405919	93
970405920	93
970405921	93
970405922	93
970405923	93
970405924	93
970405925	93
970405926	93
970405927	93
970405928	93
970405929	93

Altec P/N	Page
970405930	93
970405931	93
970405932	93
970405933	93
970405934	93
970405935	93
970405936	93
970405937	93
970405938	93
970405939	93
970405940	93
970405941	93
970405942	93
970405943	93
970405944	93
970405945	93
970405946	93
970405947	93
970405948	93
970405949	93
970405950	93
970405951	93
970405952	93
970405953	93
970405954	93
970405955	93
970405956	94
970405957	94
970405959	94
970405960	94
970405961	94
970405962	94
970405963	94
970405964	94
970405965	94
970405966	94
970405967	94
970405968	94
970405969	94
970405970	94
970405971	94
970405972	94
970405973	94
970405974	94
970405975	94
970405976	94
970405977	94
970405978	94
970405979	94
970405980	94
970405981	94
970405982	94
970405983	94
970405984	94
970405985	94
970405986	94
970405987	94
970405988	94
970405989	94
970405990	94
970405992	95
970405993	95
970405994	95
970405995	95
970405996	95
970405997	95
970405998	95
970405999	95
970406000	95
970406001	95
970406002	95
970406003	95
970406004	95
970406005	95
970406006	95
970406007	95
970406008	95

Altec P/N	Page
970406009	95
970406010	95
970406011	95
970406012	95
970406013	95
970406014	95
970406015	95
970406016	95
970406017	95
970406018	95
970406019	95
970406020	95
970406021	95
970406022	95
970406023	95
970406024	95
970406025	95
970406026	95
970406027	95
970406028	95
970406029	95
970406030	95
970406031	95
970406032	95
970406033	95
970406034	95
970406035	95
970406036	95
970406037	95
970406038	95
970406039	95
970406040	95
970406041	95
970408234	563
970408237	563
970410534	241
970410999	188
970411115	190
970412702	112
970413671	546
970417968	558
970419684	263
970424556	200
970426060	285
970428741	448
970432147	132
970434710	119, 559
970434713	46
970434714	46
970434715	46
970434716	46
970434717	46
970434718	46
970435073	184
970435083	184
970435088	182
970435089	182
970435090	182
970438445	34
970438457	34
970439469	303
970439477	84
970439478	84
970439479	84
970439480	84
970439481	84
970439482	84
970439483	84
970439484	84
970439485	84
970439486	84
970439488	84
970439489	84
970439490	84
970439491	84
970439492	84
970439493	84

Altec P/N	Page
970439494	84
970439495	84
970439496	84
970439497	84
970439500	84
970439501	84
970439502	84
970439503	84
970439504	84
970439505	84
970439506	84
970439507	84
970439508	84
970439509	84
970441568	525
970443383	144, 146
970444065	546
970444066	546
970444067	546
970444068	546
970444069	546
970444070	546
970444071	546
970444072	546
970444073	546
970444074	546
970444075	546
970444076	547
970444077	547
970444078	547
970444079	547
970444080	547
970444081	547
970444082	547
970444083	547
970444084	547
970444085	547
970444086	547
970444087	547
970444088	547
970444089	547
970444090	98
970444091	98
970444092	98
970444093	98
970444094	98
970444095	98
970444096	98
970444097	98
970444098	98
970444099	98
970444100	98
970444101	99
970444102	99
970444103	99
970444104	99
970444105	99
970444106	99
970444107	98
970444108	98
970444109	98

Altec P/N	Page
970444166	99
970444167	99
970444168	99
970444169	99
970444170	99
970444171	99
970444172	99
970444173	99
970444188	324
970444189	324
970444192	142
970444193	142
970444194	142
970444195	142
970444197	142
970444198	142
970444199	142
970444200	142
970444202	142
970444203	142
970444204	142
970444208	142
970444209	142
970444210	142
970444211	142
970444212	142
970444479	482
970444491	482
970444494	482
970444496	482
970444499	546
970444500	546
970446299	265
970449493	114
970449848	239
970450021	332
970451123	48
970451143	48
970451147	48
970451153	48
970451155	48
970451160	48
970451170	48
970451174	48
970451178	48
970451180	48
970451745	137
970454076	177
970454077	177
970454595	474
970454599	474
970454601	335
970454604	335
970457098	302
970457313	118, 165
970457839	474
970457842	474
970457843	474
970463953	468
970464021	30
970464025	30
970464120	279
970465471	243
970466026	187
970466727	328
970468856	48
970469112	139
970470254	476
970470262	476
970470269	475
970471753	526
970474864	516
970475111	43
970476279	316
970476287	316
970476299	316
970476301	316

Altec P/N	Page
970476471	325
970476472	325
970476473	325
970476474	326
970476475	326
970476476	326
970476477	326
970476478	326
970476479	326
970476480	326
970478047	563
970479249	405
970484606	195
970485292	256
970486652	514
970487014	195
970487018	195
970487025	195
970487026	195
970487027	193, 195
970487878	551
970488101	300
970488104	267
970488106	267
970489784	326
970489785	326
970489786	323
970489798	323
970489799	323
970489800	323
970489801	323
970489802	323
970489803	323
970489804	323
970489899	177
970490327	132
970490372	477
970490373	477
970490374	477
970490375	477
970490376	395
970490378	395
970490379	395
970490384	395
970490388	395
970490390	395
970490403	285
970490578	395
970490581	424
970490593	424
970490596	424
970490601	424
970490660	336
970490661	336
970490662	336
970490663	336
970490664	336
970490948	132
970491078	132
970491624	195
970491625	195
970491626	195
970491627	195
970491722	525
970491874	84
970491875	84
970491876	84
970491877	84
970491878	84
970491880	84
970491881	84
970491882	84
970491883	84
970491884	84
970491894	348
970491901	547
970492022	164

Altec P/N	Page
970492539	477
970492564	475
970492566	475
970492567	475
970492568	477
970492629	476
970492630	476
970492631	476
970492632	476
970492633	476
970492634	476
970492635	476
970492636	476
970492637	476
970492638	476
970492639	476
970492640	476
970492641	476
970492642	476
970492643	476
970492644	476
970492645	476
970492646	476
970492647	477
970492648	477
970492649	477
970492650	477
970492651	477
970492662	475
970492678	475
970492683	476
970492684	476
970492685	476
970492686	476
970492687	476
970492688	476
970492689	476
970492690	476
970492691	476
970492692	476
970492693	476
970492694	476
970492695	476
970492696	476
970492697	476
970492698	476
970492699	476
970492700	476
970492701	476
970492702	476
970492703	476
970492704	476
970492705	476
970492706	476
970492707	476
970492708	476
970492709	476
970492710	476
970492711	477
970492712	477
970492713	477
970492714	477
970492715	477
970492716	477
970492717	477
970492718	477
970492719	477
970492720	477
970492721	477
970492722	477
970492723	477
970492724	477
970492725	477
970492726	477
970492727	477
970492728	477
970492729	477

Altec P/N	Page
970492730	477
970492731	477
970492732	477
970492733	477
970492734	477
970492738	476
970492739	476
970492740	476
970492741	476
970492742	476
970492743	476
970492744	476
970492745	476
970492746	476
970492747	476
970492748	476
970492749	476
970492750	477
970492751	477
970492752	477
970492753	477
970492754	477
970492755	477
970492756	477
970492757	477
970492758	477
970492759	477
970492760	477
970492761	477
970492762	477
970492763	477
970492768	477
970492769	477
970492770	477
970492771	477
970492772	477
970492773	477
970492774	477
970492775	477
970492776	477
970492777	477
970492778	477
970492779	477
970492886	320
970492887	320
970492888	320
970492889	320
970492891	320
970493016	164
970493072	525
970493285	547
970493689	48
970493694	48
970493701	48
970493703	48
970493793	56
970494018	147
970494285	518
970494300	518
970494301	518
970496953	36
970496954	36
970496955	36
970496956	36
970496957	36
970496958	36
970496959	36
970496960	36
970496961	36
970496962	36
970496963	36
970496964	36
970496965	36
970496966	36
970496967	36
970496968	36

Altec P/N	Page
970496969	36
970496970	36
970496971	36
970496972	36
970496973	36
970496974	36
970496975	36
970496976	36
970496977	36
970496978	36
970496979	36
970496980	36
970496981	36
970496982	36
970496983	36
970496984	36
970496985	25, 97
970496986	25, 97
970496987	25, 97
970496988	25, 97
970496989	25, 97
970496990	25, 97
970496991	25, 97
970496992	25, 97
970496993	25, 97
970496994	25, 97
970496995	25, 97
970496996	25, 97
970497098	36
970497103	39
970497105	340
970497114	340
970497783	25, 97
970498440	253
970498457	271
970498458	271
970498459	271
970498474	275
970505160	195
970505161	195
970505162	195
970505163	195
970505164	195
970505165	195
970505166	195
970505167	195
970505168	195
970505169	195
970505170	195
970505171	195
970505172	195
970505173	195
970505174	195
970505175	195
970505176	195
970505177	195
970505178	195
970505179	195
970508851	190
970514308	256
970514309	256
970514805	53
970515542	197
970515543	197
970516123	446
970516128	446
970516139	120
970516566	275, 555
970516567	275, 555
970516568	555
970516569	275, 555
970516570	253, 555
970516571	253, 555
970516572	253, 555
970516573	555
970516574	555
970516575	555

Altec P/N	Page
970516576	555
970516577	556
970516578	556
970516579	556
970516580	556
970516581	556
970516582	556
970516583	556
970516584	556
970516585	556
970516586	556
970516587	556
970516588	556
970516589	556
970516590	557
970516591	557
970516592	557
970516593	557
970516594	557
970516595	557
970516596	557
970516597	557
970516598	557
970516599	563
970516600	563
970516601	563
970516602	563
970516603	563
970516604	563
970516605	563
970516606	563
970516607	563
970516608	563
970516609	563
970516610	576
970516611	576
970516612	576
970516613	576
970516614	576
970516615	576
970516616	576
970516617	576
970516618	576
970516619	576
970516620	576
970516621	576
970516622	576
970516623	576
970516624	576
970516625	576
970516626	576

Altec P/N	Page	Altec P/N	Page	Altec P/N	Page	Altec P/N	Page	Altec P/N	Page	Altec P/N	Page
970516653	576	970545565	453	970546347	565	970557902	516	970567213	60	970567290	62
970516654	576	970545566	453	970546348	565	970557903	516	970567214	60	970567291	62
970516655	576	970545567	453	970546349	565	970557904	516	970567215	60	970567292	62
970516656	576	970545568	453	970546350	565	970557905	516	970567216	60	970567293	62
970516657	576	970545569	453	970546351	565	970557906	516	970567217	60	970567294	62
970516658	576	970545570	455	970546352	565	970557907	516	970567218	60	970567295	62
970516659	576	970545571	455	970546353	565	970557908	516	970567219	60	970567296	62
970516660	576	970545572	455	970546354	565	970557909	516	970567220	60	970567297	62
970516661	576	970545573	455	970546355	566	970557910	516	970567221	60	970567298	62
970516662	576	970545574	455	970546356	566	970557911	516	970567222	60	970567299	62
970516663	576	970545575	455	970546357	566	970557912	516	970567223	60	970567300	62
970516664	576	970545576	455	970546358	566	970557913	516	970567224	60	970567301	62
970516665	576	970545577	455	970546359	566	970557914	516	970567225	60	970567302	62
970516666	576	970545578	455	970546360	566	970557915	519	970567226	60	970567303	62
970516667	576	970545579	456	970546361	566	970557916	522	970567227	60	970567304	62
970516668	576	970545580	456	970546362	566	970557917	523	970567228	60	970567305	62
970516669	576	970545581	456	970546363	566	970557918	524	970567229	60	970567306	62
970516670	576	970545582	456	970546364	566	970557919	519, 524	970567230	60	970567307	62
970516671	576	970545584	457	970546365	566	970557920	519, 524	970567231	60	970567308	62
970516672	560	970545585	457	970546366	566	970557921	525	970567232	60	970567309	62
970516673	560	970545586	457	970546367	566	970557922	526	970567233	61	970567310	62
970516674	560	970545587	457	970546368	566	970557927	519	970567234	61	970567311	62
970516675	560	970545588	458	970546369	566	970558862	146	970567235	61	970567312	62
970516676	560	970545589	458	970546370	566	970558865	146	970567236	61	970567313	62
970516677	560	970545591	458	970546371	566	970558870	146	970567237	61	970567314	62
970516678	560	970545592	458	970546372	566	970558879	146	970567238	61	970567315	62
970516679	560	970545593	458	970546373	566	970558880	146	970567239	61	970567316	62
970516680	560	970545594	459	970546374	566	970558886	146	970567240	61	970567317	62
970516681	561	970545595	136	970546375	566	970558886	146	970567241	61	970567318	62
970516682	561	970545596	491	970546376	566	970558934	146	970567242	61	970567319	62
970516683	561	970545597	491	970546377	566	970558936	146	970567243	61	970567320	62
970516684	562	970545598	470	970546378	566	970558938	146	970567244	61	970567321	62
970516685	562	970545599	470	970546379	566	970559110	146	970567245	61	970567322	62
970516686	562	970545600	465	970546380	566	970559119	144, 146	970567246	61	970567323	62
970516687	562	970545601	465	970546381	566	970559122	145, 146	970567247	61	970567324	62
970516688	562	970545602	465	970546382	566	970559546	540	970567248	61	970567325	62
970516689	562	970545604	465	970546383	566	970560112	189	970567249	61	970567326	63
970516690	52	970545605	465	970546384	566	970566322	189	970567250	61	970567327	63
970516691	52	970545606	564	970546385	566	970567172	473	970567251	61	970567328	63
970516692	52	970545607	564	970546386	566	970567173	473	970567252	61	970567329	63
970516693	52	970545608	564	970546387	567	970567174	473	970567253	61	970567330	63
970516694	52	970545609	564	970546388	567	970567175	473	970567254	61	970567331	63
970516695	52	970545610	564	970546389	567	970567176	473	970567255	61	970567332	63
970516696	52	970545611	564	970546390	567	970567177	473	970567256	61	970567333	63
970516697	52-53	970545612	564	970546391	567	970567178	473	970567257	61	970567334	63
970516698	53	970545613	564	970546392	567	970567179	473	970567258	61	970567335	63
970516699	53	970545614	564	970546393	567	970567180	473	970567259	61	970567336	63
970516701	164, 209	970545615	564	970546394	567	970567181	473	970567260	61	970567337	63
970516702	164, 209	970545616	564	970546395	567	970567182	473	970567261	61	970567338	63
970516703	164, 209	970545617	564	970546396	567	970567183	473	970567262	61	970567339	63
970522258	138	970545618	564	970546397	567	970567184	473	970567263	61	970567340	63
970527206	407	970545619	564	970546398	567	970567185	473	970567264	61	970567341	63
970527715	526	970545620	564	970546399	567	970567186	473	970567265	61	970567342	63
970528222	324	970545621	564	970546530	564	970567187	473	970567266	61	970567343	63
970528421	278	970545622	564	970546533	564	970567188	473	970567267	61	970567344	63
970528997	69	970545623	564	970548416	465	970567189	473	970567268	61	970567345	63
970529432	47	970545624	564	970550832	31	970567190	473	970567269	61	970567346	63
970530060	30	970545625	564	970551049	241	970567191	473	970567270	61	970567347	63
970530302	285	970545626	564	970551242	205	970567192	473	970567271	61	970567348	63
970530305	285	970545627	564	970551326	60	970567193	473	970567272	61	970567349	63
970531142	56	970545628	564	970551343	60	970567194	473	970567273	61	970567350	63
970532400	332	970545629	564	970551344	60	970567195	473	970567274	61	970567351	63
970538195	53	970545631	564	970551345	60	970567196	473	970567275	61	970567352	63
970538979	526	970545632	564	970551346	60	970567197	473	970567276	61	970567353	63
970540785	46	970545634	564	970551347	60	970567198	473	970567277	61	970567354	63
970545553	450	970545635	564	970551348	60	970567199	473	970567278	61	970567355	63
970545554	453	970545636	564	970551350	60	970567200	473	970567279	61	970567356	63
970545555	453	970545637	564	970551351	60	970567201	473	970567280	61	970567357	63
970545556	453	970545638	564	970551353	60	970567202	473	970567281	61	970567358	68
970545557	453	970545639	564	970551354	60	970567203	473	970567282	61	970567359	68
970545558	453	970546065	407	970552334	323	970567204	474	970567283	61	970567360	63
970545559	453	970546341	565	970557896	512	970567205	474	970567284	61	970567361	63
970545560	453	970546342	565	970557897	512	970567208	254	970567285	61	970567362	63
970545561	453	970546343	565	970557898	513	970567209	60	970567286	61	970567363	63
970545562	453	970546344	565	970557899	513	970567210	60	970567287	61	970567364	63
970545563	453	970546345	565	970557900	513	970567211	60	970567288	61	970567365	63
970545564	453	970546346	565	970557901	513	970567212	60	970567289	62	970567366	63

PRODUCT INDEX

BY ALTEC ITEM NUMBER

USA: 1-877-GO ALTEC
(1-877-462-5832)

www.alteccconnect.com

Altec P/N	Page
970567367	63
970567368	63
970567369	63
970567370	63
970567371	63
970567372	63
970567373	63
970567374	63
970567375	63
970567376	63
970567377	63
970567378	63
970567379	63
970567380	63
970567381	63
970567382	63
970567383	63
970567384	63
970567385	63
970567386	63
970567387	63
970567388	63
970567389	63
970567390	63
970567391	63
970567392	63
970567393	63
970567394	63
970567395	63
970567396	63
970567397	63
970567398	63
970567399	66
970567400	66
970567401	66
970567402	66
970567403	66
970567404	66
970567405	66
970567406	66
970567407	67
970567408	67
970567409	67
970567410	67
970567411	67
970567412	67
970567413	67
970567414	67
970567415	67
970567416	67
970567417	67
970567418	67
970567419	67
970567420	67
970567421	67
970567422	67
970567423	67
970567424	67
970567425	67
970567426	67
970567427	67
970567428	67
970567429	67
970567430	67
970567431	67
970567432	67
970567433	67
970567434	67
970567435	68
970567436	68
970567437	68
970567438	68
970567439	68
970567440	68
970567441	68
970567442	68
970567443	68

Altec P/N	Page
970567444	68
970567445	68
970567446	68
970567447	68
970567448	68
970567449	68
970567450	68
970567451	68
970567452	68
970567453	68
970567454	68
970567455	68
970567456	68
970567457	68
970567458	68
970567459	68
970567460	68
970567461	68
970567462	68
970567463	68
970567464	68
970567465	68
970567466	68
970567467	68
970567468	68
970567469	68
970567470	68
970567471	68
970567472	68
970567473	68
970567474	68
970567475	68
970567476	68
970567477	68
970567478	68
970567479	68
970567480	68
970567481	68
970567482	68
970567483	69
970567484	69
970567485	69
970567486	68
970567487	69
970567488	69
970567489	69
970567490	69
970567491	69
970567492	69
970567493	69
970567494	69
970567495	69
970567496	69
970567497	69
970567498	69
970567500	69
970567501	69
970567502	69
970567503	69
970567504	69
970567505	69
970567506	69
970567507	69
970567508	69
970567509	69
970567510	69
970567511	69
970567512	69
970567513	69
970567514	69
970567515	69
970567516	69
970567517	69
970567518	69
970567519	69
970567520	69
970567521	69

Altec P/N	Page
970567522	69
970567523	69
970567524	70
970567525	70
970567526	70
970567527	70
970567528	70
970567529	70
970567530	70
970567531	70
970567532	70
970567533	70
970567534	70
970567535	70
970567536	70
970567537	70
970567538	70
970567539	70
970567540	70
970567541	70
970567542	70
970567543	70
970567544	70
970567545	71
970567546	71
970567547	71
970567548	71
970567549	71
970567550	71
970567551	71
970567552	71
970567553	71
970567554	71
970567555	71
970567556	71
970567557	71
970567558	71
970567559	71
970567560	71
970567561	71
970567562	71
970567563	71
970567564	71
970567565	71
970567566	71
970567567	71
970567568	71
970567569	71
970567570	71
970567571	71
970567572	71
970567573	71
970567574	71
970567575	71
970567576	71
970567577	71
970567578	71
970567579	71
970567580	71
970567581	71
970567582	71
970567583	71
970567584	71
970567585	71
970567586	71
970567587	71
970567588	71
970567589	71
970567590	71
970567591	71
970567592	71
970567593	71
970567594	71
970567595	71
970567596	71
970567597	71
970567598	71

Altec P/N	Page
970567599	69
970567788	35
970567791	35
970567793	35
970567797	35
970567798	35
970567809	35
970567814	35
970567818	35
970567874	351
970567933	68
970567936	69
970568106	67
970568588	282
970568590	282
970568594	282
970568595	282
970568596	283
970568598	283
970568599	283
970568772	15
970568798	107
970568800	107
970568802	107
970568803	107
970568813	106
970568815	107
970568816	106
970568817	106
970568821	106
970568913	411
970569567	105
970570180	190
970570186	190
970570190	190
970570192	190
970570197	190
970570202	191
970570208	191
970570283	191
970570285	191
970570287	191
970570292	190
970570322	188
970570324	189
970570958	342, 345
970571088	188
970571105	188
970571107	138
970571108	138
970571428	377
970583981	104
970583993	104
970583999	104
970584003	104
970584698	324
970584699	324
970584822	462
970584823	462
970584824	462
970584825	462
970584827	463
970584828	463
970584829	463
970584830	463
970586234	514
970586546	511
970586556	511
970586594	48
970586784	526
970587448	138
970587760	327
970588598	547
970588599	547
970588600	547
970588601	547
970588602	547

Altec P/N	Page
970588603	547
970588604	547
970588605	547
970588606	547
970588607	547
970588608	548
970588609	548
970588610	548
970588611	548
970588612	548
970588613	548
970588614	548
970588615	548
970588616	79
970588617	79
970588618	79
970588619	79
970588624	77
970588625	77
970588626	77
970588627	77
970588628	77
970588629	77
970588630	77
970588631	77
970588640	79
970588641	79
970588642	79
970588643	79
970588644	79
970588645	79
970588646	79
970588647	79
970588648	81
970588649	81
970588650	81
970588652	81
970588653	81
970588654	81
970588655	81
970588656	81
970588657	81
970588658	81
970588659	81
970588660	81
970588662	81
970588663	81
970588664	81
970588665	81
970588666	81
970588675	81
970588676	81
970588677	81
970588678	81
970588679	81
970588679	81
970588680	81
970588681	81
970588682	81
970588683	81
970588684	81
970588685	81
970588686	81
970588687	81
970588688	81
970588689	81
970588690	81
970588691	81
970588692	81
970588693	81
970588694	81
970588695	96
970588696	96
970588697	96
970588698	96
970588699	96
970588700	96

Altec P/N	Page
970588702	195
970588703	195
970588704	195
970588705	195
970588706	154
970588707	154
970588708	154
970588709	154
970588710	154
970588711	154
970588712	154
970588713	154
970588714	154
970588715	154
970588716	154
970588717	154
970588718	154
970588719	154
970588720	154
970588721	154
970588722	154
970588723	155
970588724	155
970588725	155
970588726	155
970588727	155
970588728	155
970588729	155
970588730	155
970588731	155
970588732	155
970588733	155
970588734	155
970588735	155
970588736	155
970588737	155
970588738	155
970588739	155
970588740	155
970588741	155
970588742	155
970588743	155
970588744	155
970588745	155
970588746	155
970588747	155
970588748	155
970588749	155
970588750	155
970588751	186
970588752	186
970588753	186
970588754	186
970588756	207
970588757	207
970588758	388
970588759	388
970588760	388
970588761	334
970588762	334
970588763	334
9705	

**PRODUCT INDEX
BY ALTEC ITEM NUMBER**

**USA: 1-877-GO ALTEC
(1-877-462-5832)**

www.alteconnect.com

Altec P/N	Page
970588782	337
970588783	338
970588784	338
970588785	338
970588786	338
970588787	231
970588788	231
970588789	231
970588790	231
970588791	231
970588792	231
970588793	231
970588794	231
970588795	231
970588796	231
970588797	231
970588798	137
970588799	231
970588802	239
970588803	239
970588804	239
970588805	239
970588806	239
970588807	239
970588808	239
970588809	239
970588810	239
970588811	239
970588812	239
970588813	239
970588814	239
970588815	239
970588816	239
970588817	239
970588818	239
970588819	239
970588820	239
970588821	239
970588822	239
970588823	239
970588824	239
970588825	239
970588826	239
970588827	241
970588828	241
970588829	241
970588830	241
970588831	241
970588832	241
970588833	242
970588834	245
970588835	245
970588836	245
970588837	245
970588838	245
970588839	246, 527
970588840	246, 527
970588841	246, 527
970588842	246, 527
970588843	246, 527
970588844	246, 527
970588845	246, 527
970588846	246, 527
970588847	246, 527
970588848	246, 527
970588849	246, 527
970588850	246, 527
970588851	246, 527
970588852	246, 527
970588853	246, 527
970588854	246, 527
970588855	246, 527
970588856	246, 527
970588857	246, 527
970588858	246, 527
970588859	246, 527
970588860	246, 527

Altec P/N	Page
970588861	246, 527
970588862	246, 527
970588863	246, 527
970588864	246, 527
970588865	158
970588866	158
970588867	81, 158
970588868	81, 158
970588869	81, 158
970588870	81, 158
970588871	81, 158
970588872	81, 158
970588873	81, 158
970588874	159
970588875	159
970588876	159
970588877	159
970588878	159
970588879	159
970588880	186
970588881	186
970588882	186
970588883	186
970588884	186
970588885	186
970588886	186
970588887	186
970588888	238
970588889	238
970588890	238
970588891	238
970588892	238
970588893	238
970588894	238
970588895	238
970588896	238
970588897	238
970588898	238
970588899	238
970588900	238
970588901	238
970588902	238
970588903	238
970588904	238
970588905	238
970588906	238
970588907	238
970588908	238
970588909	238
970588910	238
970588911	238
970588912	238
970588913	238
970589131	541
970594905	247
970595100	180
970595115	184
970595119	185
970595187	138
970595336	58
970595340	58
970595349	58
970595350	58
970595355	58
970595486	57
970595555	185
970595629	541
970601099	50
970601101	50
970601110	51
970601113	51
970601120	51
970601305	137
970601307	137
970601460	193
970601467	193

Altec P/N	Page
970602755	467
970602756	467
970602757	467
970603045	256
970603048	256
970603051	256
970603054	256
970603055	256
970603056	256
970603069	256
970603073	256
970603075	256
970603119	193
970603126	193
970603132	154
970604053	161
970605592	380
970607780	138
970607789	138
970607992	56
970619921	161
970619935	161
970620113	205
970620117	30
970622247	138
970622254	138
970622257	138
970622265	138
970622268	138
970622271	138
970622272	138
970622273	138
970622274	138
970625115	55
970626254	168
970636622	120
970637039	263
970637109	100
970637110	100
970637112	100
970637113	100
970637114	100
970637115	100
970637116	100
970637117	100
970637118	100
970637119	100
970637120	100
970637121	100
970637122	100
970637123	100
970637124	100
970637125	100
970637126	100
970637127	418
970637128	418
970637129	418
970637130	418
970637131	302
970637132	302
970637133	320
970637134	320
970637135	362
970637136	362
970637137	362
970637138	362
970637139	362
970637140	363
970637141	363
970637142	363
970637143	363
970637144	363
970637145	363
970637146	363
970637147	363
970637148	363

Altec P/N	Page
970637149	363
970637150	363
970637151	363
970637152	363
970637153	363
970637154	363
970637155	363
970637156	363
970637157	363
970637158	363
970637159	363
970637160	363
970637161	363
970637162	363
970637163	363
970637164	363
970637165	363
970637166	363
970637167	363
970637168	363
970637169	364
970637170	320
970637171	320
970637172	320
970637173	320
970637174	320
970637175	320
970637176	321
970637177	321
970637178	321
970637179	321
970637180	321
970637181	321
970637184	50
970637185	55
970637186	56
970637187	56
970637188	56
970637189	485
970637190	485
970637191	485
970637192	485
970637193	485
970637194	485
970637195	485
970637196	485
970637197	485
970637198	485
970637199	485
970637200	485
970637201	489
970637202	489
970637203	489
970637204	43
970637205	43
970637206	43
970637207	43
970637208	43
970637209	43
970637210	43
970637211	43
970637212	43
970637213	43
970637214	43
970637215	43
970637216	43
970637217	43
970637218	43
970637219	43
970637220	43
970637221	43
970637222	43
970637223	43
970637224	43
970637225	43
970637226	43
970637227	43

Altec P/N	Page
970637228	43
970637229	43
970637230	288
970637231	288
970637232	288
970637233	288
970637234	288
970637235	288
970637236	288
970637237	288
970637238	288
970637239	288
970637240	288
970637241	288
970637242	288
970637243	288
970637244	288
970637245	288
970637246	288
970637247	288
970637248	288
970637249	288
970637250	288
970637251	288
970637252	288
970637253	288
970637254	288
970637255	288
970637256	288
970637257	288
970637258	288
970637259	288
970637260	288
970637261	288
970637262	288
970637263	288
970637264	288
970637265	288
970637266	288
970637267	288
970637268	288
970637269	288
970637270	288
970637271	288
970637272	288
970637273	288
970637274	288
970637275	289
970637276	289
970637277	289
970637278	289
970637279	289
970637280	197
970637281	276
970637282	278
970637283	278
970637284	278
970637285	278
970637286	278
970637287	278
970637288	278
970637289	278
970637291	278
970637292	278
970637293	278
970637294	278
970637295	278
970637296	278
970637297	278
970637298	278
970637299	278
970637300	278
970637301	114
970637302	114
970637303	114
970637304	114
970637305	114

Altec P/N	Page
970637306	114
970637307	114
970637308	114
970637309	114
970637310	114
970637311	114
970637312	114
970637313	114
970637314	114
970637315	114
970637316	114
970637317	114
970637318	114
970637319	114
970637320	114
970637321	114
970637322	114
970637323	115
970637324	115
970637325	115
970637326	323
970637327	325
970637328	325
970637329	327
970637330	327
970637331	332
970637332	285
970637333	285
970637334	285
970637335	285
970637336	285
970637337	285
970637338	290
970637339	290
970637340	290
970637342	461
970637343	461
970637344	461
970637345	461
970637346	461
970637347	148
970637348	148
970637349	148
970637350	148
970637351	148
970637352	148
970637353	149
970637354</	

PRODUCT INDEX

BY ALTEC ITEM NUMBER

USA: 1-877-GO ALTEC
(1-877-462-5832)

www.alteconnect.com

Altec P/N	Page
970637385	203
970637386	203
970637387	391
970637388	392
970637389	392
970637390	392
970637391	392
970637392	393
970637393	393
970637394	393
970637395	394
970637396	394
970637397	394
970637398	394
970637399	394
970637400	394
970637401	394
970637402	394
970637403	394
970637404	394
970637405	394
970637406	394
970637407	256
970637408	256
970637409	256
970637410	256
970637411	256
970637412	256
970637413	256
970637414	256
970637415	256
970637416	528
970637417	528
970637418	528
970637419	528
970637420	528
970637421	528
970637422	528
970637423	528
970637424	528
970637425	528
970637426	528
970637427	528
970637428	528
970637429	528
970637430	528
970637431	528
970637432	528
970637433	528
970637434	528
970637435	528
970637436	528
970637437	528
970637438	528
970637439	528
970637440	528
970637441	528
970637442	528
970637443	528
970637444	528
970637445	528
970637446	528
970637447	528
970637448	528
970637449	528
970637450	528
970637451	528
970637452	528
970637453	528
970637454	528
970637455	528
970637456	528
970637457	528
970637458	528
970637459	528
970637460	528
970637461	528

Altec P/N	Page
970637462	528
970637463	528
970637464	528
970637465	528
970637466	528
970637467	528
970637468	528
970637469	528
970637470	528
970637471	528
970637472	528
970637473	528
970637474	529
970637475	529
970637476	529
970637477	529
970637478	529
970637479	529
970637480	529
970637481	529
970637482	529
970637483	529
970637485	529
970637486	529
970637487	529
970637488	529
970637489	529
970637490	529
970637491	529
970637492	529
970637493	529
970637494	529
970637495	529
970637496	529
970637497	380
970637498	380
970637499	380
970637500	380
970637502	380
970637503	380
970637504	380
970637505	380
970637506	380
970637507	380
970637508	380
970637509	380
970637510	380
970637511	381
970637512	381
970637513	85
970637514	85
970637515	85
970637516	85
970637517	85
970637518	85
970637519	85
970637520	85
970637521	85
970637522	85
970637523	85
970637524	85
970637525	85
970637526	85
970637527	85
970637528	85
970637529	85
970637530	85
970637531	85
970637532	85
970637533	85
970637534	85
970637535	85
970637536	85
970637537	85
970637538	85
970637539	85

Altec P/N	Page
970637540	85
970637541	85
970637542	85
970637543	85
970637544	85
970637545	85
970637546	85
970637547	85
970637548	85
970637549	85
970637550	85
970637551	85
970637552	85
970637553	85
970637554	85
970637555	463
970637556	463
970637557	253
970637558	373
970637559	373
970637560	373
970637561	373
970637562	373
970637563	373
970637564	373
970637565	373
970637566	373
970637567	373
970637568	373
970637569	373
970637570	373
970637571	304
970637572	304
970637573	304
970637574	304
970637575	305
970637581	250
970637582	250
970637583	250
970637584	250
970637585	250
970637586	250
970637587	250
970637588	250
970637589	250
970637590	250
970637603	270
970637604	270
970637605	270
970637606	270
970637607	270
970637608	270
970637609	270
970637610	270
970637611	270
970637612	270
970637613	270
970637614	271
970637615	271
970637616	271
970637617	271
970637618	271
970637619	271
970637620	271
970637621	271
970637622	272
970637623	272
970637624	272
970637625	272
970637626	272
970637627	272
970637628	272
970637629	272
970637630	272
970637631	272
970637632	272
970637633	272

Altec P/N	Page
970637634	272
970637635	272
970637636	273
970637637	273
970637638	273
970637639	273
970637640	273
970637641	273
970637642	273
970637643	273
970637644	274
970637645	274
970637646	274
970637647	274
970637648	274
970637649	274
970637650	274
970637651	274
970637652	274
970637653	274
970637890	278
970638355	149
970638584	114
970640270	30
970640771	30
970640772	30
970640773	30
970640774	30
970640775	30
970640776	30
970640777	30
970640778	30
970640779	101, 559
970640780	101, 559
970640781	101, 559
970640782	101, 559
970640783	54
970640784	46
970640786	42
970640787	42
970640788	42
970640789	42
970640790	120
970640791	120
970640792	120
970640793	120
970640794	201
970640795	201
970640796	268
970640797	263
970640798	263
970640799	266
970640800	257
970640801	257
970640802	301
970640804	307
970640805	307
970640806	307
970640808	362
970640809	411
970640810	433
970640811	411
970640812	485
970640813	484
970640814	250
970640815	250
970640816	250
970640817	250
970640818	250
970640819	250
970640820	250
970640821	250
970640822	250
970640823	250
970640824	250
970640825	250
970640826	250

Altec P/N	Page
970640827	250
970640828	250
970640829	274
970640830	275
970640831	275
970640832	275
970640833	275
970640835	275
970640836	275
970640837	373
970640838	80
970640839	80
970640840	80
970640841	80
970640842	80
970640843	80
970640844	80
970640845	80
970640846	80
970640847	80
970640848	80
970640849	80
970640850	80
970640851	80
970640852	80
970640853	80
970640854	80
970640855	80
970640856	80
970640857	80
970640858	80
970640859	80
970640860	80
970640861	332
970640862	332
970640863	332
970640864	332
970640865	332
970640866	332
970640867	405
970640868	405
970640869	405
970640870	406
970640871	406
970640872	406
970640873	406
970640874	406
970640875	407
970640876	407
970640877	407
970640878	407
970640879	407
970640880	407
970640881	407
970640882	407
970640883	407
970640884	409
970641164	29
970641339	201
970641341	275
970641368	549
970641442	549
970641551	539
970647510	214
970648980	219
970648983	219
970648985	219
970648986	219
970648988	219
970648991	219
970648994	219
970648995	219
970648997	219
970648998	219
970648999	219
970649000	219

Altec P/N	Page
970649003	219
970649004	219
970649005	219
970649010	219
970649992	370
981702798	133
970650203	141
970650205	141
970650206	141
970650208	141
970650210	141
970650211	141
981752734	373
981752738	373
981752740	373
981752741	373
981752744	373
981752769	381
981753230	373
981753232	373
981753233	373
981753398	373
981753398	373
981753399	373
981753400	373
981753401	373
991001204	124
991004350	169
991005339	169
991005344	169
991005372	373
991005376	373

SUPPLIER PART NUMBER PRODUCT INDEX

**PRODUCT INDEX
BY SUPPLIER ITEM NUMBER**

**USA: 1-877-GO ALTEC
(1-877-462-5832)**

www.alteconnect.com

AIRCRAFT DYNAMICS

SUPPLIER P/N	ALTEC PN	PAGE
2001	970637359	385
2002	970637360	385
2004	970637361	385
2008	970637356	385
2010	970637357	385
2016	970637358	385
2403	970198708	365
2516	970637367	341
2523	970188912	341
2524	970186731	341
2525	970186730	341
2526	970196931	341
2527	970198710	341
2528	970198711	341
2529	970198790	341
2530	970328388	341
2531	970198791	341
2532	970637371	341
2533	970637369	341
2534	970637372	341
2536	970637373	341
2537	970637374	341
2542	970637368	341
2543	970637370	341
2590	970186306	341
2751	970198705	365
2756	970300876	340
2757	970198706	365
2775	970157240	365
2779	970198226	365
2801	970198707	365
3419	970637364	340
3481	970240718	385
4376	970357792	340
4419	970637365	340
4420	970637366	340
5060	970186315	385
5061	970186316	385
5074	900050214	153
5228	970186313	385
5276	970104847	153
5309	970186297	340
5310	970357788	340
5415	970198796	153
5456	970389126	152
5478	970102567	152
5479	970356907	153
5600	970497105	340
5601	970637362	340
5602	970637363	340
5603	970497114	340
5611	970637378	204
5617	970637376	204
7002	970637375	204
7006	970637377	204
9296	970198792	341
7015-A	970186299	202
7015-R	970154190	202
7026-A	970186301	202
7026-R	970186300	202
7032-A	970186318	202
7032-R	970186317	202
7038-R	970183193	202
7039-A	970186305	202
7167-A	970243264	203
7167-R	970243401	203
7175-A	970243402	203
7175-R	970357286	203

AIRCRAFT DYNAMICS

SUPPLIER P/N	ALTEC PN	PAGE
7177-A	970637386	203
7177-R	970637385	203
7219-A	970637384	203
7219-R	970637383	203
7315-A	970637380	202
7315-R	970637379	202
7360-A	970637382	203
7360-R	970637381	203

ALCOA

SUPPLIER P/N	ALTEC PN	PAGE
07CD	970366515	343
08CD	970366516	343
09CD	970366517	343
10007CD	970366732	347
10008CD	970366733	347
10009CD	970366734	347
10010CD	970366735	347
10010SH	970366746	347
10011CD	970366736	347
10012CD	970366737	347
10012SH	970366747	347
10013CD	970366738	347
10014CD	970366739	347
10014SH	970366748	347
10015CD	970366740	347
10016CD	970366741	347
10016SH	970299246	347
10017CD	970366742	347
10018CD	970366743	347
10018SH	970366749	347
10019CD	970366744	347
10020AH	970366717	347
10020CD	970366745	347
10020SH	970366750	347
10024AH	970366718	347
10027AH	970366719	347
10030AH	970366720	347
10034AH	970366721	347
10036AH	970366722	347
10038AH	970366723	347
10040AH	970366724	347
10042AH	970366728	347
10044AH	970366729	347
10046AH	970366730	347
10048AH	970366731	347
10074AH	970366725	347
10074SH	970366715	347
10075AH	970366726	347
10075SH	970366716	347
10076AH	970366727	347
11AH	970366508	343
13AH-80EA	970366520	343
20AH-14AH	970366509	343
6007CD	970366673	347
6008CD	970062586	347
6009CD	970062652	347
6010CD	970062589	347
6010SH	970062651	347
6011CD	970062590	347
6012CD	970062591	347
6012SH	970062654	347
6013CD	970062593	347
6014CD	970062653	347
6014SH	970062656	347
6015CD	970366674	347
6016CD	970366675	347
6016SH	970366677	347

ALCOA

SUPPLIER P/N	ALTEC PN	PAGE
6017CD	970366676	347
6018SH	970279462	347
6020AH	970062664	347
6020SH	970062650	347
6024AH	970062665	347
6027AH	970062666	347
6030AH	970062669	347
6034AH	970062670	347
6036AH	970062584	347
6038AH	970294760	347
6040AH	970279467	347
6074AH	970062663	347
6074SH	970279459	347
6075AH	970366672	347
6075SH	970062659	347
6076AH	970062661	347
6076SH	970062660	347
72AH	970366513	343
72SH-01SH	970366518	343
73AH-08AH	970366514	343
73SH	970366519	343
74AH-10AH	970366510	343
74SH-035SH	970366505	343
75AH-12AH	970366511	343
75SH-05SH	970366506	343
76AH	970366512	343
76SH	970366507	343

ALLEN / APEX

SUPPLIER P/N	ALTEC PN	PAGE
56600G	970637634	272
56601G	970637635	272

ALTEC SUPPLY

SUPPLIER P/N	ALTEC PN	PAGE
	970158450	102
	970158451	102
	970158452	102
	970158447	102
	970158449	102
	970158443	102
	970158445	102
	970158441	102
	900090090	14
	900090091	14
	900090093	14
	900090092	15
	970568772	15
	970333786	22
	970333787	22
	970079999	123
	900050304	123
	900050320	123
	900050340	123
	900050506	123
	900051103	123
	701993015	123
	970089243	123
	900050501	123
	900051311	123
	900050511	123
	900050516	123
	900065703	123
	970098047	123
	970079998	124
	900000535	124
	970238939	124
	900045120	124
	970098046	124
	991001204	124

ALTEC SUPPLY

SUPPLIER P/N	ALTEC PN	PAGE
	970082768	124
	900011700	124
	900059022	125
	900062655	125
	900027155	125
	900027150	125
	970080002	125
	970080001	125
	900027555	125
	900027550	125
	970080007	125
	970080003	125
	970185305	125
	970185305	125
	900001006	125
	70420456	125
	970321837	126
	970321843	126
	970321844	126
	970353135	126
	970347486	126

ALTURNAMATS

SUPPLIER P/N	ALTEC PN	PAGE
AMCP3	970180809	141
AMCP4	970122731	141
CM48	970650203	141
CM38	970650205	141
CM36	970650206	141
CM28	970650208	141
CM26	970650210	141
CM24	970650211	141
PAD1515.75	970201144	141
PAD18181	970133273	141
PAD24241	970201146	141
PAD24242	970108329	141
WMCP3	970201148	141
WMCP4	970201147	141
AM48	900021810	141
AM28	970029104	141
AM26	970071445	141
AM24	970071447	141
WM28	970071153	141
WM26	970071155	141
WM24	970071156	141
AMHH	970039308	141
RTL-S	970039309	141
FTL-S	970039325	141
FTL-D	970039327	141
RTL-DG	970039328	141

AMERICAN PNEUMATIC

SUPPLIER P/N	ALTEC PN	PAGE
260	970199809	389
5214	970120318	389
5214-03	970346635	389
5214-04	970346636	389

AMERICAN POLYWATER

SUPPLIER P/N	ALTEC PN	PAGE
B-1	970084328	29
B-D72	900096201	29
FD-16LF	970176848	28
FD-35LF	970176849	28
FD-9	970176850	28
HP-16LF	970176851	28
HP-35LF	970176852	28

AMERICAN POLYWATER

SUPPLIER P/N	ALTEC P/N	PAGE
HPY-12	970176855	28
HTC-D72	900096202	29
RBG-35LR	970063375	29
RBG-D72	970129493	29
S-1	900096200	29
ST-R	970176847	28
ST-R	970176847	28
W-1	970641164	29
W-16	970216393	29
J-35	900099494	492
J-128	900099495	492
J-640	900099496	492
WJ-35	900099497	492
WJ-128	900099498	492
WJ-640	900099499	492
F-35	900099500	492
F-128	900099501	492
F-640	900099502	492
WF-35	900099503	492
WF-128	900099504	492
WF-640	900099505	492

ARMSTRONG / APEX

SUPPLIER P/N	ALTEC P/N	PAGE
64-046	970637641	273
64-086	970637642	273
66-501	970637603	270
66-504	970637604	270
66-507	970637605	270
66-510	970637606	270
66-526	970637608	270
66-530	970637609	270
66-580	970637610	270
66-614	970637607	270
69-552	970637644	274
69-647	970516593	557
69-653	970516594	557

AUGER TECHNOLOGIES - ALASKAUG

SUPPLIER P/N	ALTEC P/N	PAGE
5608A	970637416	528
5608B	970637428	528
5608C	970637434	528
5609A	970637417	528
5609B	970102234	528
5609C	970637435	528
5610A	970637418	528
5610B	970637429	528
5610C	970637436	528
5612A	970637419	528
5612B	970637430	528
5612C	970637437	528
5614A	970637420	528
5614B	970637431	528
5614C	970637438	528
5616A	970637421	528
5616B	705400199	528
5616C	970637439	528
5618A	970637422	528
5618B	705400223	528
5618C	970637440	528
5620A	970637423	528
5620B	970063246	528
5620C	970637441	528
5622A	970637424	528
5622B	970072864	528
5622C	970637442	528
5624A	970637425	528
5624B	970063249	528
5624C	970637443	528
5630A	970637426	528

AUGER TECHNOLOGIES - ALASKAUG

SUPPLIER P/N	ALTEC P/N	PAGE
5630B	970637432	528
5630C	970637444	528
5636A	970637427	528
5636B	970637433	528
5636C	970637445	528
5710A	970637446	528
5710B	970637456	528
5710C	970637464	528
5712A	970637447	528
5712B	970637457	528
5712C	970637465	528
5714A	970637448	528
5714B	970637458	528
5714C	970637466	528
5716A	970637449	528
5716B	970637459	528
5716C	970637467	528
5718A	970637450	528
5718B	970637460	528
5718C	970637468	528
5720A	970637451	528
5720B	70090104	528
5720C	970637469	528
5722A	970637452	528
5722B	970057483	528
5722C	970637470	528
5724A	970637453	528
5724B	970637461	528
5724C	970637471	528
5730A	970637454	528
5730B	970637462	528
5730C	970637472	528
5736A	970637455	528
5736B	970637463	528
5736C	970637473	528
9208A	970637474	529
9208B	970637474	529
9208C	970637488	529
9210A	970637475	529
9210B	705400193	529
9210C	970637489	529
9212A	970637476	529
9212B	701705078	529
9212C	970637490	529
9214A	970637477	529
9214B	970637485	529
9214C	970637491	529
9216A	970637478	529
9216B	70090246	529
9216C	970637492	529
9218A	705400575	529
9218B	701705071	529
9218C	970637493	529
9220A	970637479	529
9220B	701705044	529
9220C	970028248	529
9224A	970637480	529
9224B	701705072	529
9224C	970042033	529
9230A	970637481	529
9230B	701705073	529
9230C	970637494	529
9232A	970637482	529
9232B	970637486	529
9232C	970637495	529
9236A	970637483	529
9236B	970637487	529
9236C	970637496	529
AT-75	970637409	256
AT-75C	970637407	256
AT-75CCR	970637410	256
AT-75-SR	970637408	256

AUGER TECHNOLOGIES - ALASKAUG

SUPPLIER P/N	ALTEC P/N	PAGE
AT-75WA	970637415	256
AT85	970637411	256
AT85	970637412	256
AT85	970637413	256
AT85	970637414	256
S-130-A	894002400	529
S-130-A	970354970	529
S-130-B	970354965	529
S-130-B	970354975	529
S-130-C	970354967	529
S-130-C	970354980	529

BASHLIN INDUSTRIES

SUPPLIER P/N	ALTEC P/N	PAGE
145	970091312	561
145	970091312	38
217	970640811	411
610	970516686	562
930	970568913	411
#2	900020200	37
111H LDS	970021953	38
111H LDSX	900099956	38
111HLS	970091296	38
111HLSX	970091298	38
111LWH	970092825	38
111LWHX	970278851	38
11DC	970092826	561
11DCS	970127995	561
12.75BLJREG-28/32	970366079	74
12.75BLJREG-28/34	970366090	74
12.75BLJREG-28/36	970366101	74
12.75BLJREG-30/32	970366080	74
12.75BLJREG-30/34	970366091	74
12.75BLJREG-30/36	970366102	74
12.75BLJREG-32/32	970366081	74
12.75BLJREG-32/34	970366092	74
12.75BLJREG-32/36	970366103	74
12.75BLJREG-34/32	970366082	74
12.75BLJREG-34/34	970366093	74
12.75BLJREG-34/36	970366104	74
12.75BLJREG-36/32	970366083	74
12.75BLJREG-36/34	970366094	74
12.75BLJREG-36/36	970366105	74
12.75BLJREG-38/32	970366084	74
12.75BLJREG-38/34	970366095	74
12.75BLJREG-38/36	970366106	74
12.75BLJREG-40/32	970366085	74
12.75BLJREG-40/34	970366096	74
12.75BLJREG-40/36	970366107	74
12.75BLJREG-42/32	970366086	74
12.75BLJREG-42/34	970366097	74
12.75BLJREG-42/36	970366108	74
12.75BLJREG-44/32	970366087	74
12.75BLJREG-44/34	970366098	74
12.75BLJREG-44/36	970366109	74
12.75BLJREG-46/32	970366088	74
12.75BLJREG-46/34	970366099	74
12.75BLJREG-46/36	970366110	74
12.75BLJREG-48/32	970366089	74
12.75BLJREG-48/34	970366100	74
12.75BLJREG-48/36	970366111	74
12.75BLJREG-SW-30/32	970366144	74
12.75BLJREG-SW-28/32	970366143	74
12.75BLJREG-SW-28/34	970366154	74
12.75BLJREG-SW-28/36	970366165	74
12.75BLJREG-SW-30/34	970366155	74
12.75BLJREG-SW-30/36	970366166	74
12.75BLJREG-SW-32/32	970366145	74
12.75BLJREG-SW-32/34	970366156	74
12.75BLJREG-SW-32/36	970366167	74

BASHLIN INDUSTRIES

SUPPLIER P/N	ALTEC P/N	PAGE
12.75BLJREG-SW-34/32	970366146	74
12.75BLJREG-SW-34/34	970366157	74
12.75BLJREG-SW-34/36	970366168	74
12.75BLJREG-SW-36/32	970366147	74
12.75BLJREG-SW-36/34	970366158	74
12.75BLJREG-SW-36/36	970366169	74
12.75BLJREG-SW-38/32	970366148	74
12.75BLJREG-SW-38/34	970366159	74
12.75BLJREG-SW-38/36	970366170	74
12.75BLJREG-SW-40/32	970366149	74
12.75BLJREG-SW-40/34	970366160	74
12.75BLJREG-SW-40/36	970366171	74
12.75BLJREG-SW-42/32	970366150	74
12.75BLJREG-SW-42/34	970366161	74
12.75BLJREG-SW-42/36	970366172	74
12.75BLJREG-SW-44/32	970366151	74
12.75BLJREG-SW-44/34	970366162	74
12.75BLJREG-SW-44/36	970366173	74
12.75BLJREG-SW-46/32	970366152	74
12.75BLJREG-SW-46/34	970366163	74
12.75BLJREG-SW-48/36	970366175	74
12.75BLJREL-28/32	970366112	74
12.75BLJREL-28/34	970366122	74
12.75BLJREL-28/36	970366132	74
12.75BLJREL-30/32	970366113	74
12.75BLJREL-30/34	970366123	74
12.75BLJREL-30/36	970366133	74
12.75BLJREL-32/32	970366114	74
12.75BLJREL-32/34	970366124	74
12.75BLJREL-32/36	970366134	74
12.75BLJREL-34/32	970364948	74
12.75BLJREL-34/34	970362037	74
12.75BLJREL-34/36	970366135	74
12.75BLJREL-36/32	970366115	74
12.75BLJREL-36/34	970366125	74
12.75BLJREL-36/36	970366136	74
12.75BLJREL-38/32	970366116	74
12.75BLJREL-38/34	970366126	74
12.75BLJREL-38/36	970366137	74
12.75BLJREL-40/32	970366117	74
12.75BLJREL-40/34	970366127	74
12.75BLJREL-40/36	970366138	74
12.75BLJREL-42/32	970366118	74
12.75BLJREL-42/34	970366128	74
12.75BLJREL-42/36	970366139	74
12.75BLJREL-44/32	970366119	74
12.75BLJREL-44/34	970366129	74
12.75BLJREL-44/36	970366140	74
12.75BLJREL-46/32	970366120	74
12.75BLJREL-46/34	970366130	74
12.75BLJREL-46/36	970366141	74
12.75BLJREL-48/32	970366121	74
12.75BLJREL-48/34	970366131	74
12.75BLJREL-48/36	970366142	74
12.75BLJREL-SW-28/32	970366176	74
12.75BLJREL-SW-28/34	970366187	74
12.75BLJREL-SW-28/36	970366198	74
12.75BLJREL-SW-30/32	970366177	74
12.75BLJREL-SW-30/34	970366188	74
12.75BLJREL-SW-30/36	970366199	74
12.75BLJREL-SW-32/32	970366178	74
12.75BLJREL-SW-32/34	970366189	74
12.75BLJREL-SW-32/36	970366200	74
12.75BLJREL-SW-34/32	970366179	74
12.75BLJREL-SW-34/34	970366190	74
12.75BLJREL-SW-34/36	970366201	74
12.75BLJREL-SW-36/32	970366180	74
12.75BLJREL-SW-36/34	970366191	74
12.75BLJREL-SW-36/36	970366202	74
12.75BLJREL-SW-38/32	970366181	74
12.75BLJREL-SW-38/34	970366192	74
12.75BLJREL-SW-38/36	970366203	74
12.75BLJREL-SW-40/32	970366182	74
12.75BLJREL-SW-40/34	970366193	74

PRODUCT INDEX
 BY SUPPLIER ITEM NUMBER

USA: 1-877-GO ALTEC
 (1-877-462-5832)

</

BASHLIN INDUSTRIES

BASHLIN INDUSTRIES

BASHLIN INDUSTRIES

BASHLIN INDUSTRIES

**PRODUCT INDEX
BY SUPPLIER ITEM NUMBER**

**USA: 1-877-GO ALTEC
(1-877-462-5832)**

www.alteconnect.com

SUPPLIER P/N	ALTEC P/N	PAGE	SUPPLIER P/N	ALTEC P/N	PAGE	SUPPLIER P/N	ALTEC P/N	PAGE	SUPPLIER P/N	ALTEC P/N	PAGE
12.75BLJREL-SW-40/36	970366204	74	14BLJREG-SW-40/32	970329425	73	14BLJREL-SW-44/36	970331508	73	87N	900087000	37
12.75BLJREL-SW-42/32	970366183	74	14BLJREG-SW-40/34	970331443	73	14BLJREL-SW-46/32	970329442	73	88UX4DCC-D18	970496975	36
12.75BLJREL-SW-42/34	970366194	74	14BLJREG-SW-40/36	970331494	73	14BLJREL-SW-46/34	970331462	73	88UX4DCC-D19	970496976	36
12.75BLJREL-SW-42/36	970366205	74	14BLJREG-SW-42/32	970329426	73	14BLJREL-SW-46/36	970331509	73	88UX4DCC-D20	970496977	36
12.75BLJREL-SW-44/32	970366184	74	14BLJREG-SW-42/34	970331444	73	14BLJREL-SW-48/32	970329444	73	88UX4DCC-D21	970496978	36
12.75BLJREL-SW-44/34	970366195	74	14BLJREG-SW-42/36	970331495	73	14BLJREL-SW-48/34	970331463	73	88UX4DCC-D22	970496979	36
12.75BLJREL-SW-44/36	970366206	74	14BLJREG-SW-44/32	970329427	73	14BLJREL-SW-48/36	970331510	73	88UX4DCC-D23	970496980	36
12.75BLJREL-SW-46/32	970366185	74	14BLJREG-SW-44/34	970331445	73	150V	970089478	38	88UX4DCC-D24	970496981	36
12.75BLJREL-SW-46/34	970366196	74	14BLJREG-SW-44/36	970331496	73	1590C	900099370	411	88UX4DCC-D25	970496982	36
12.75BLJREL-SW-46/36	970366207	74	14BLJREG-SW-46/32	970329428	73	1-877-GO ALTEC	39		88UX4DCC-D26	970496983	36
12.75BLJREL-SW-48/32	970366186	74	14BLJREG-SW-46/34	970331447	73	1990REST	970361912	40	88UX4DCC-D27	970496984	36
12.75BLJREL-SW-48/34	970366197	74	14BLJREG-SW-46/36	970331497	73	2304-6HLREST	970361914	40	88UX4DCC-D28	970497098	36
12.75BLJREL-SW-48/36	970366208	74	14BLJREG-SW-48/32	970329429	73	25B5	900025000	38	88UX4DMP-D18	970496953	36
140D	900081429	38	14BLJREG-SW-48/34	970331450	73	2804-4HL	970181780	562	88UX4DMP-D19	970496954	36
140DS	900008142	38	14BLJREG-SW-48/36	970331498	73	2804-5HL	970516685	562	88UX4DMP-D20	970496955	36
145 ACV	970091300	38	14BLJREL-28/32	970314488	73	2804-6HL	705400562	562	88UX4DMP-D21	970496956	36
145 BCV	970091308	38	14BLJREL-28/34	970331377	73	336A	900099706	411	88UX4DMP-D22	970496957	36
145AC	970091310	561	14BLJREL-28/36	970331475	73	4016NX-8	970229424	560	88UX4DMP-D23	970496958	36
145AC	970091310	38	14BLJREL-30/32	970314489	73	4019NX-8	970361919	560	88UX4DMP-D24	970496959	36
145ACVW	970091310	561	14BLJREL-30/34	970331378	73	4019NX-8	970361919	36	88UX4DMP-D25	970496960	36
145BC	970091311	561	14BLJREL-30/36	970331477	73	4019UX-8	970361920	36	88UX4DMP-D26	970496961	36
145BC	970091311	38	14BLJREL-32/32	970314490	73	51N-2HL	900099825	38	88UX4DMP-D27	970496962	36
145BCVW	970091311	561	14BLJREL-32/34	970331379	73	52N-2HL	970023352	38	88UX4DMP-D28	970496963	36
14BLJREG-28/32	970314477	72	14BLJREL-32/36	970331478	73	53N-2HL	970089474	38	88UXB4DMP-D18	970496964	36
14BLJREG-28/34	970331366	73	14BLJREL-34/32	970314491	73	610A-24	970516687	562	88UXB4DMP-D19	970496965	36
14BLJREG-28/36	970331464	73	14BLJREL-34/34	970331381	73	610A-26	970516688	562	88UXB4DMP-D20	970496966	36
14BLJREG-30/32	970314478	73	14BLJREL-34/36	970331479	73	613A	970516689	562	88UXB4DMP-D21	970496967	36
14BLJREG-30/34	970331367	73	14BLJREL-36/32	970314492	73	637-L	970516674	560	88UXB4DMP-D22	970496968	36
14BLJREG-30/36	970331465	73	14BLJREL-36/34	970331383	73	637-M	970516673	560	88UXB4DMP-D23	970496969	36
14BLJREG-32/32	970314479	73	14BLJREL-36/36	970331480	73	637-S	970516672	560	88UXB4DMP-D24	970496970	36
14BLJREG-32/34	970331368	73	14BLJREL-38/32	970314493	73	637-XL	970516675	560	88UXB4DMP-D25	970496971	36
14BLJREG-32/36	970331466	73	14BLJREL-38/34	970331384	73	662AC-O	970516684	562	88UXB4DMP-D26	970496972	36
14BLJREG-34/32	970314480	73	14BLJREL-38/36	970331481	73	669-L	900070065	560	88UXB4DMP-D27	970496973	36
14BLJREG-34/34	970331369	73	14BLJREL-40/32	970314494	73	669-M	9702292984	560	88UXB4DMP-D28	970496974	36
14BLJREG-34/36	970331467	73	14BLJREL-40/34	970331387	73	669-S	970131085	560	89N	900089000	37
14BLJREG-36/32	970314481	73	14BLJREL-40/36	970331482	73	669-XL	970516676	560	930T	970640809	411
14BLJREG-36/34	970331370	73	14BLJREL-42/32	970314495	73	7.5HENLS - 3X-LARGE	970366403	75	930TG	970274210	411
14BLJREG-36/36	970331468	73	14BLJREL-42/34	970331388	73	7.5HENLS - LARGE	970366400	75	930UT	970630074	411
14BLJREG-38/32	970314482	73	14BLJREL-42/36	970331483	73	7.5HENLS - MEDIUM	970366399	75	960Y	970254292	561
14BLJREG-38/34	970331371	73	14BLJREL-44/32	970314496	73	7.5HENLS - SMALL	970366398	75	BD14-1N	970018231	37
14BLJREG-38/36	970331469	73	14BLJREL-44/34	970331390	73	7.5HENLS - X-LARGE	970366401	75	BD14-2N	970089473	37
14BLJREG-40/32	970314483	73	14BLJREL-44/36	970331484	73	7.5HENLS - XX-LARGE	970366402	75	BD14-3N	970081109	37
14BLJREG-40/34	970331372	73	14BLJREL-46/32	970314497	73	7.5TLS - 3X-LARGE	970366397	75	BD14-4N	970092831	37
14BLJREG-40/36	970331470	73	14BLJREL-46/34	970331393	73	7.5TLS - LARGE	970366394	75	BD14-5N	970092832	37
14BLJREG-42/32	970314484	73	14BLJREL-46/36	970331485	73	7.5TLS - MEDIUM	970366393	75	BD-14T-1N	970182523	561
14BLJREG-42/34	970331373	73	14BLJREL-48/32	970314498	73	7.5TLS - SMALL	970366392	75	BD-14T-1N	970182523	561
14BLJREG-42/36	970331471	73	14BLJREL-48/34	970331394	73	7.5TLS - X-LARGE	970366395	75	BD-14T-2N	970182510	561
14BLJREG-44/32	970314485	73	14BLJREL-48/36	970331486	73	7.5TLS - XX-LARGE	970366396	75	BD-14T-2N	970182510	37
14BLJREG-44/34	970331374	73	14BLJREL-SW-28/32	970329430	73	700FP	900000610	40	BD-14T-5N	900093059	561
14BLJREG-44/36	970331472	73	14BLJREL-SW-28/34	970331452	73	700WI	66030007	40	BD-14T-5N	900093059	37
14BLJREG-46/32	970314486	73	14BLJREL-SW-28/36	970331499	73	703BHS	970497103	39	BD16B-1N	970091313	37
14BLJREG-46/34	970331375	73	14BLJREL-SW-30/32	970329431	73	78A-2HL	970076929	38	BD16B-2N	970091316	37
14BLJREG-46/36	970331473	73	14BLJREL-SW-30/34	970331453	73	78B-2HL	970091563	38	BD16B-3N	970092828	37
14BLJREG-48/32	970314487	73	14BLJREL-SW-30/36	970331500	73	78X-2HL	970091562	38	BD16B-4N	970092829	37
14BLJREG-48/34	970331376	73	14BLJREL-SW32/32	970329432	73	7BLS-2XL	970314511	76	BD16B-5N	970092830	37
14BLJREG-48/36	970331474	73	14BLJREL-SW-32/34	970331454	73	7BLS-3XL	970314512	76	BD-16BT-1N	970292987	561
14BLJREG-SW-30/32	970329418	73	14BLJREL-SW-32/36	970331501	73	7BLS-KH-2XLARGE	970329661	76	BD-16BT-2N	970516681	561
14BLJREG-SW-28/32	970329409	73	14BLJREL-SW34/32	970329433	73	7BLS-KH-3XLARGE	970329662	76	BD-16BT-4N	970516682	561
14BLJREG-SW-28/34	970331437	73	14BLJREL-SW-34/34	970331456	73	7BLS-KH-LARGE	970329659	76	BD-16BT-5N	970516683	561
14BLJREG-SW-28/36	970331487	73	14BLJREL-SW-34/36	970331502	73	7BLS-KH-MEDIUM	970329658	76	MODEL 662		39
14BLJREG-SW-30/34	970331438	73	14BLJREL-SW-36/32	970329434	73	7BLS-KH-SMALL	970329657	76	MODEL 662AC		
14BLJREG-SW-30/36	970331488	73	14BLJREL-SW-36/34	970331457	73	7BLS-KH-XLARGE	970329660	76	MODEL 662RD	CALL	
14BLJREG-SW-32/32	970329419	73	14BLJREL-SW-36/36	970331503	73	7BLS-LARGE	970314509	76	MODEL 683XC	1-877-GO ALTEC	39
14BLJREG-SW-32/34	970331439	73	14BLJREL-SW-38/32	970329436	73	7BLS-MEDIUM	970314508	76	MODEL 683XD		39
14BLJREG-SW-32/36	970331489	73	14BLJREL-SW-38/34	970331458	73	7BLS-SMALL	970314507	76	PAYOUT REEL	970619935	161
14BLJREG-SW-34/32	970329420	73	14BLJREL-SW-38/36	970331504	73	7BLS-SW-2XLARGE	970331345	76	Q88GX4DMP-D22	970359846	36
14BLJREG-SW-34/34	970331440	73	14BLJREL-SW-40/32	970329437	73	7BLS-SW-3XLARGE	970331346	76	Q88GX4DMP-D23	970355144	36
14BLJREG-SW-34/36	970331490	73	14BLJREL-SW-40/34	970331459	73	7BLS-SW-LARGE	970331343	76	Q88GX4DMP-D24	970359853	36
14BLJREG-SW-36/32	970329421	73	14BLJREL-SW-40/36	970331506	73	7BLS-SW-MEDIUM	970331342	76	Q88GX4DMP-D25	970359854	36
14BLJREG-SW-36/34	970331441	73	14BLJREL-SW-42/32	970329438	73	7BLS-SW-SMALL	970331341	76	Q88GX4DMP-D26	970359856	36
14BLJREG-SW-36/36	970331492	73	14BLJREL-SW-42/34	970331460	73	7BLS-SW-X-LARGE	970331344	76	REST	970361888	40
14BLJREG-SW-38/32	970329423	73	14BLJREL-SW-42/36	970331507	73	7BLS-XL	970314510	76	SMTSIBS+LA-L	970516679	560
14BLJREG-SW-38/34	970331442	73	14BLJREL-SW-44/32	970329440	73	85N	900009350	37	SMTSIBS+LA-M	970516678	560
14BLJREG-SW-38/36	970331493	73	14BLJREL-SW-44/34	970331461	73	86N	900085000	37	SMTSIBS+LA-S	970516677	560



BASHLIN INDUSTRIES

SUPPLIER P/N	ALTEC PN	PAGE
SMTSIBS-LA-XL	970516680	560
SR683PKWL-150	970164174	40
SR683PKWL-75	970164173	40
SRPAK-150	970164179	40
SRPAK-75	970164176	40

BIERER & ASSOCIATES

SUPPLIER P/N	ALTEC PN	PAGE
AV40	970248220	551
PD25	970248180	550
PD800W	970299717	550
PG48S	970545598	470
PG72S	970545599	470
PR1COM	970248176	550
ST500PGN	970309641	551
ST800PGN	970487878	551
VDAO40P	970248181	551
SRPAK-150	970164179	40
SRPAK-75	970164176	40

BLAYLOCK INDUSTRIES

SUPPLIER P/N	ALTEC PN	PAGE
TCK8	878660060	162

BONE SAFETY

SUPPLIER P/N	ALTEC PN	PAGE
PM4848BPTSOC	970261116	17
PM4848DETOUROC	970356912	17
PM4848DMSOC	970356391	17
PM4848ECOC	970356400	17
PM4848FAOC	970355944	17
PM4848FSOC	970282632	17
PM4848LCAOC	970355955	17
PM4848LLCAOC	970355985	17
PM4848LLCOC	970313577	17
PM4848MLSOC	970313579	17
PM4848MRSOC	970313578	17
PM4848MWOC	970313575	17
PM4848OLRAOC	970355975	17
PM4848RCA3OC	970356394	17
PM4848RCOC	970313573	17
PM4848RCOC	970313573	17
PM4848RLCAOC	970355982	17
PM4848RLCOC	970313576	17
PM4848RWAO	970356396	17
PM4848TEHOC	970356928	17
PM4848TWAOC	970356925	17
PM4848UC 1 MILE	970282625	17
PM4848UC 1/2 MILE	970282631	17
PM4848UCAOC	970355978	17
PM4848UWAOC	970274916	17
PM4848WSOC	970355964	17
PMO-0823-LEFTOC	970375140	16
PMO-0823-RIGHTOC	970375141	16
PMO-0830-1000FOC	970375143	16
PMO-0830-1500FOC	970375144	16
PMO-0830-500FOC	970375142	16
PMO-1238-BLRMOC	970375145	16
RE4848BPTSOC	970271340	17
RE4848DETOUROC	970246294	17
RE4848DMSOC	970267921	17
RE4848ECOC	970196005	17
RE4848FAOC	970156010	17
RE4848FSOC	970233756	17
RE4848LCAOC	970299675	17
RE4848LLCAOC	970251309	17

BONE SAFETY

SUPPLIER P/N	ALTEC PN	PAGE
RE4848LLCOC	970356956	17
RE4848MLSOC	970356978	17
RE4848MRSOC	970356977	17
RE4848MWOC	970246295	17
RE4848OLRAOC	970271341	17
RE4848RCA3OC	970251318	17
RE4848RCOC	970246292	17
RE4848RCOC	970246292	17
RE4848RLCAOC	970156004	17
RE4848RLCOC	970308121	17
RE4848RWAO	970299671	17
RE4848TEHOC	970349028	17
RE4848TWAOC	970246293	17
RE4848UC 1 MILE	970356939	17
RE4848UC 1/2 MILE	970356953	17
RE4848UCAOC	970156003	17
RE4848UWAOC	970207457	17
RE4848WSOC	970251325	17
REO-0823-LEFTOC	970271343	16
REO-0823-RIGHTOC	970251315	16
REO-0830-1000FOC	970305483	16
REO-0830-1500FOC	970305484	16
REO-0830-500FOC	970305482	16
REO-1238-BLRMOC	970267923	16
STOP-1812R	970155240	18
STOP-1884R	970156012	18
STOP-2484DG/HI	970355933	19
STOP-2484HI	970262793	19
STOP-2484R	900050467	19
STOP-COVER-18	970160915	18
STOP-COVER-24	970180326	18
SZ-412	970156009	18
SZ-412-2S	970284690	18
SZ-412-2S-RB	970177636	18
SZ-412-S	970156008	18
SZ-412-S-UB	970299679	18
SZ-412-UB	970283761	18
SZ-460	970248822	18
SZ-460-2S	970374997	18
SZ-460-2S-RB	970375006	18
SZ-460-UB	970374980	18
SZ-484	970375007	18
SZ-484-2S	970375019	18
SZ-484-2S-RB	970375026	18
SZ-484-UB	970375012	18

BUCKINGHAM

SUPPLIER P/N	ALTEC PN	PAGE
694	970236519	563
2402	970145107	48
2639	970181322	51
2639	970181322	51
3118	900070181	51
3120	970134328	51
3126	970189044	51
3813	900099605	54
3813	900099605	54
6150	69299207	160
7091	970358605	57
31181	970601120	51
35032	970119093	51
9-8	970162864	47
61501	970095171	160
350321	970601110	51
101SR-50	900010150	54
101SR-50	900010150	563
105RS	970085515	54
105RSK1	970640783	54
106-50	970208468	54
106-50	970208468	563
126K	970625115	55
17907-L	970637187	56

BUCKINGHAM

SUPPLIER P/N	ALTEC PN	PAGE
17907-M	970637186	56
2000M-BL20	970135523	49
2000M-BL20	970357667	49
2000M-BL21	900070656	49
2000M-BL21	970309737	49
2000M-BL22	970115609	49
2000M-BL22	900070588	49
2000M-BL23	970118243	49
2000M-BL23	970357691	49
2000M-BL24	970192302	49
2000M-BL24	970150760	49
2000M-BL25	970136728	49
2000M-BL25	970323033	49
2000M-BL26	970153797	49
2000M-BL26	970298615	49
2000M-BL27	970357654	49
2000M-BL27	970357677	49
2000M-BL28	970135529	49
2000M-BL28	970357694	49
20182M-D18	970451147	48
20182M-D19	970493689	48
20182M-D20	970451174	48
20182M-D21	970451143	48
20182M-D22	970451180	48
20182M-D23	970451153	48
20182M-D24	970451123	48
20182M-D25	970451170	48
20182M-D26	970451155	48
20182M-D27	970451160	48
20182M-D28	970451178	48
20182M-D29	970493694	48
20182M-D30	970493701	48
20182M-D31	970493703	48
20182M-D32	970468856	48
2019M-D22	970229443	48
2019M-D23	970229442	48
2019M-D23	970229450	48
2019M-D24	970232979	48
2019M-D24	970263492	48
2019M-D25	970229441	48
2019M-D25	970229902	48
2019M-D26	970222175	48
2019M-D26	970229440	48
2019M-D27	970256213	48
2019M-D27	970229439	48
2019M-D28	970237175	48
2019M-D28	970222851	48
2019M-D29	970293121	48
2019M-D29	970229438	48
2019M-D30	970329803	48
2019M-D30	970236116	48
2019M-D31	970238338	48
2019M-D31	970231692	48
2022-L	970516600	563
2022-M	893940080	563
2022-S	970516599	563
2022-XL	970516601	563
21401C	970586594	48
301SR-110	970357782	55
301SR-160	970357786	55
301SR-50	970357775	55
301SR-65	970357777	55
336099E	970358352	47
336699E	970358374	47
337099E	970358385	47
337699E	970358388	47
338099E	970358409	47
3500C	970058105	51
35021C	970601113	51
3502C	970054740	51
355BT	970208462	54
3808-L	970408234	563
3808-M	970240951	563
3808-S	970516607	563

BUCKINGHAM

SUPPLIER P/N	ALTEC PN	PAGE
3808-XL	970408237	563
3813D1	900050550	563
3816L	970637185	55
3852-L	893803660	563
3852-M	970478047	563
3852-S	970516608	563
3852-XL	970516609	563
39078TAG1-4	970514805	53
39078TAG1-7	970516699	53
41333C7R5W3	970361916	57
4266BL	970244431	57
4370B14	970358630	57
4371B14	970358608	57
45911M2	970254260	57
48129W2Y-10	970357771	47
48129W2Y-6	970357749	47
48129W2Y-7	970357763	47
48129W2Y-8	970342646	47
48129W2Y-9	970357766	47
488R	970312216	47
488RQ4	970357722	47
488RT	970348658	47
488RTQ4	970357725	47
488TW2	970357716	47
488TW2Q3	970357707	47
488W2	970315663	47
488W2Q3	970357697	47
5005S3	970538195	53
50061A-4	970516691	52
50061A-4/100	970516694	52
50061A-4/80	970516693	52
50061A-7	970516692	52
50061A-7/100	970516696	52
50061A-7/80	970516695	52
50061B	970516690	52
5007R1	970516697	52-53
5007R2	970516698	53
52993BL	970158997	57
52993BR	970151532	57
5919-L	970516605	563
5919-M	970516604	563
5919-S	970516603	563
5919-XL	970516606	563
5919-XS	970516602	563
5V67AQ1	970493793	56
6008K-74+Y+Z	970353164	56
6263-L	970323555	49
6263-M	970303214	49
6263-S	970303209	49
6263-XL	970303215	49
6264-L	970358437	49
6264-M	970358436	49
6264-S	970358413	49
6264-XL	970358440	49
6393700-L	70420871	56
68D7G8C600K1-L	970257015	56
68D7G8C600K1-XL	970074188	56
68D98C74COK4-L	970531142	56
68D98C74COK4-X	970637188	56
6909A	970248768	51
69		

USA: 1-877-GO ALTEC (1-877-462-5832) www.alteconnect.com **PRODUCT INDEX** BY SUPPLIER ITEM NUMBER

BULWARK

BULWARK

BULWARK

BULWARK

SUPPLIER P/N	ALTEC PN	PAGE	SUPPLIER P/N	ALTEC PN	PAGE	SUPPLIER P/N	ALTEC PN	PAGE	SUPPLIER P/N	ALTEC PN	PAGE
(SLG8-HN)	970346210	63	BLF8-ND	970346047	67	JLP8-NV	970567537	70	PEJ8DW-44/30	970345979	64
(SLG8-HN)	970346211	63	BLF8-ND	970346048	67	JLP8-NV	970567538	70	PEJ8DW-44/32	970345991	64
(SLG8-HN)	970346212	63	BLF8-ND	970346044	67	JLP8-NV	970567539	70	PEJ8DW-44/34	970346003	64
(SLG8-HN)	970346213	63	BLF8-ND	970346041	67	JLP8-NV	970567540	70	PEJ8DW-46/30	970345980	64
(SLG8-HN)	970346214	63	BLF8-ND	970346042	67	JLP8-NV	970567541	70	PEJ8DW-46/32	970345992	64
(SLG8-HN)	970346215	63	BLF8-ND	970346043	67	PEJ6SW-28/30	970345926	64	PEJ8DW-46/34	970346004	64
(SLG8-HN)	970346216	63	BLN4-BD	970567426	67	PEJ6SW-28/32	970345941	64	PEJ8DW-48/30	970345981	64
(SLG8-HN)	970346217	63	BLN4-BD	970567427	67	PEJ6SW-28/34	970345956	64	PEJ8DW-48/32	970345993	64
(SLG8-HN)	970346218	63	BLN4-BD	970567428	67	PEJ6SW-30/30	970345927	64	PEJ8DW-48/34	970346005	64
(SLG8-HN)	970346219	63	BLN4-BD	970567429	67	PEJ6SW-30/32	970345942	64	PEJ8DW-50/30	970345982	64
(SLG8-HN)	970346220	63	BLN4-BD	970567430	67	PEJ6SW-30/34	970345957	64	PEJ8DW-50/32	970345994	64
(SLG8-NK)	970346221	63	BLN4-BD	970567431	67	PEJ6SW-31/30	970345928	64	PEJ8DW-50/34	970346006	64
(SLG8-NK)	970346222	63	BLN4-BD	970567432	67	PEJ6SW-31/32	970345943	64	PEJ8SW-30/30	970346007	64
(SLG8-NK)	970346223	63	BLN4-BD	970567433	67	PEJ6SW-31/34	970345958	64	PEJ8SW-30/32	970346017	64
(SLG8-NK)	970346224	63	BLN4-BD	970567434	67	PEJ6SW-32/30	970345929	64	PEJ8SW-30/34	970264144	64
(SLG8-NK)	970346225	63	HMB2NV	970567542	70	PEJ6SW-32/32	970345944	64	PEJ8SW-32/30	970346008	64
(SLG8-NK)	970346226	63	HMC4NV	970567543	70	PEJ6SW-32/34	970345959	64	PEJ8SW-32/32	970346018	64
(SLG8-NK)	970346227	63	HNB2NA	970567544	70	PEJ6SW-33/30	970345930	64	PEJ8SW-32/34	970346026	64
(SLG8-NK)	970346228	63	JEW2-NV	970567524	70	PEJ6SW-33/32	970345945	64	PEJ8SW-34/30	970346009	64
(SLG8-NK)	970346229	63	JEW2-NV	970567525	70	PEJ6SW-33/34	970345960	64	PEJ8SW-34/32	970346019	64
(SLG8-NK)	970346230	63	JEW2-NV	970567526	70	PEJ6SW-34/30	970345931	64	PEJ8SW-34/34	970346027	64
(SLG8-NK)	970346231	63	JEW2-NV	970567527	70	PEJ6SW-34/32	970345946	64	PEJ8SW-36/30	970264148	64
(SLG8-RK)	970346232	63	JEW2-NV	970567528	70	PEJ6SW-34/34	970345961	64	PEJ8SW-36/32	970346020	64
(SLG8-RK)	970346233	63	JEW2-NV	970567529	70	PEJ6SW-35/30	970345932	64	PEJ8SW-36/34	970259003	64
(SLG8-RK)	970346234	63	JEW2-NV	970567530	70	PEJ6SW-35/32	970345947	64	PEJ8SW-38/30	970346010	64
(SLG8-RK)	970346235	63	JEW2-NV	970567531	70	PEJ6SW-35/34	970345962	64	PEJ8SW-38/32	970259005	64
(SLG8-RK)	970346236	63	JEW2-NV	970567532	70	PEJ6SW-36/30	970345933	64	PEJ8SW-38/34	970346028	64
(SLG8-RK)	970346237	63	JLC4BD	970567399	66	PEJ6SW-36/32	970345948	64	PEJ8SW-40/30	970346011	64
(SLG8-RK)	970346238	63	JLC4BD	970567400	66	PEJ6SW-36/34	970345963	64	PEJ8SW-40/32	970346021	64
(SLG8-RK)	970346239	63	JLC4BD	970567401	66	PEJ6SW-38/30	970345934	64	PEJ8SW-40/34	970346029	64
(SLG8-RK)	970346240	63	JLC4BD	970287609	66	PEJ6SW-38/32	970345949	64	PEJ8SW-42/30	970346012	64
(SLG8-RK)	970346241	63	JLC4BD	970567402	66	PEJ6SW-38/34	970345964	64	PEJ8SW-42/32	970346022	64
(SLG8-RK)	970346242	63	JLC4BD	970567403	66	PEJ6SW-40/30	970345935	64	PEJ8SW-42/34	970346030	64
(SLG8-RN)	970346243	63	JLC4BD	970567404	66	PEJ6SW-40/32	970345950	64	PEJ8SW-44/30	970346013	64
(SLG8-RN)	970346244	63	JLC4BD	970567405	66	PEJ6SW-40/34	970345965	64	PEJ8SW-44/32	970346023	64
(SLG8-RN)	970346245	63	JLC4BD	970567406	66	PEJ6SW-42/30	970345936	64	PEJ8SW-44/34	970346031	64
(SLG8-RN)	970346246	63	JLF6-BK	970567500	69	PEJ6SW-42/32	970345951	64	PEJ8SW-46/30	970346014	64
(SLG8-RN)	970346247	63	JLF6-BK	970567501	69	PEJ6SW-42/34	970345966	64	PEJ8SW-46/32	970274147	64
(SLG8-RN)	970346248	63	JLF6-BK	970567502	69	PEJ6SW-44/30	970345937	64	PEJ8SW-46/34	970346032	64
(SLG8-RN)	970346249	63	JLF6-BK	970567503	69	PEJ6SW-44/32	970345952	64	PEJ8SW-48/30	970346015	64
(SLG8-RN)	970346250	63	JLF6-BK	970567504	69	PEJ6SW-44/34	970345967	64	PEJ8SW-48/32	970346024	64
(SLG8-RN)	970346251	63	JLF6-BK	970567505	69	PEJ6SW-46/30	970345938	64	PEJ8SW-48/34	970346033	64
(SLG8-RN)	970346252	63	JLF6-BK	970567506	69	PEJ6SW-46/32	970345953	64	PEJ8SW-50/30	970346016	64
(SLG8-RN)	970346253	63	JLF6-BK	970567507	69	PEJ6SW-46/34	970345968	64	PEJ8SW-50/32	970346025	64
BLC8-NV	970567408	67	JLF6-BK	970567508	69	PEJ6SW-48/30	970345939	64	PEJ8SW-50/34	970346034	64
BLC8-NV	970567409	67	JLF6-BK	970567509	69	PEJ6SW-48/32	970345954	64	PEJM-SD-28/30	970346262	65
BLC8-NV	970567410	67	JLF6-BK	970567510	69	PEJ6SW-48/34	970345969	64	PEJM-SD-28/32	970346274	65
BLC8-NV	970567411	67	JLF6-BK	970567511	69	PEJ6SW-50/30	970345940	64	PEJM-SD-28/34	970346286	65
BLC8-NV	970567412	67	JLF6-NV	970567512	69	PEJ6SW-50/32	970345955	64	PEJM-SD-30/30	970346263	65
BLC8-NV	970567413	67	JLF6-NV	970567513	69	PEJ6SW-50/34	970345970	64	PEJM-SD-30/32	970346275	65
BLC8-NV	970567414	67	JLF6-NV	970567514	69	PEJ8DW-28/30	970345971	64	PEJM-SD-30/34	970346287	65
BLC8-NV	970567415	67	JLF6-NV	970567515	69	PEJ8DW-28/32	970345983	64	PEJM-SD-32/30	970346264	65
BLC8-NV	970567416	67	JLF6-NV	970567516	69	PEJ8DW-28/34	970345995	64	PEJM-SD-32/32	970346276	65
BLC8-NV	970567417	67	JLF6-NV	970567517	69	PEJ8DW-30/30	970345972	64	PEJM-SD-32/34	970346288	65
BLC8-NV	970567418	67	JLF6-NV	970567518	69	PEJ8DW-30/32	970345984	64	PEJM-SD-34/30	970346265	65
BLC8-NV	970567419	67	JLF6-NV	970567519	69	PEJ8DW-30/34	970345996	64	PEJM-SD-34/32	970346277	65
BLC8-NV	970567420	67	JLF6-NV	970567520	69	PEJ8DW-32/30	970345973	64	PEJM-SD-34/34	970346289	65
BLC8-NV	970567421	67	JLF6-NV	970567521	69	PEJ8DW-32/32	970345985	64	PEJM-SD-36/30	970346266	65
BLC8-NV	970567422	67	JLF6-NV	970567522	69	PEJ8DW-32/34	970345997	64	PEJM-SD-36/32	970346278	65
BLC8-NV	970567423	67	JLF6-NV	970567523	69	PEJ8DW-34/30	970345974	64	PEJM-SD-36/34	970346290	65
BLC8-NV	970567424	67	JLH4BD-2XL-LONG	970346155	66	PEJ8DW-34/32	970345986	64	PEJM-SD-38/30	970346267	65
BLC8-NV	970567425	67	JLH4BD-2XL-REG	970346161	66	PEJ8DW-34/34	970345998	64	PEJM-SD-38/32	970346279	65
BLF8-BD	970346039	67	JLH4BD-3XL-REG	970346156	66	PEJ8DW-36/30	970345975	64	PEJM-SD-38/34	970346291	65
BLF8-BD	970346040	67	JLH4BD-4XL-REG	970346157	66	PEJ8DW-36/32	970345987	64	PEJM-SD-40/30	970346268	65
BLF8-BD	970264138	67	JLH4BD-L-LONG	970346153	66	PEJ8DW-36/34	970345999	64	PEJM-SD-40/32	970346280	65
BLF8-BD	970258994	67	JLH4BD-L-REG	970341992	66	PEJ8DW-38/30	970345976	64	PEJM-SD-40/34	970346292	65
BLF8-BD	970289089	67	JLH4BD-M-REG	970346158	66	PEJ8DW-38/32	970345988	64	PEJM-SD-42/30	970346269	65
BLF8-BD	970346038	67	JLH4BD-S-REG	970346159	66	PEJ8DW-38/34	970346000	64	PEJM-SD-42/32	970346281	65
BLF8-BD	970346035	67	JLH4BD-XL-LONG	970346154	66	PEJ8DW-40/30	970345977	64	PEJM-SD-42/34	970346293	65
BLF8-BD	970346036	67	JLH4BD-XL-REG	970346160	66	PEJ8DW-40/32	970345989	64	PEJM-SD-44/30	970346270	65
BLF8-BD	970346037	67	JLP8-NV	970567533	70	PEJ8DW-40/34	970346001	64	PEJM-SD-44/32	970346282	65
BLF8-ND	970567407	67	JLP8-NV	970567534	70	PEJ8DW-42/30	970345978	64	PEJM-SD-44/34	970346294	65
BLF8-ND	970346046	67	JLP8-NV	970567535	70	PEJ8DW-42/32	970345990	64	PEJM-SD-46/30	970346271	65
BLF8-ND	970346045	67	JLP8-NV	970567536	70	PEJ8DW-42/34	970346002	64	PEJM-SD-46/32	970346283	65



BULWARK

BULWARK

BULWARK

BULWARK

SUPPLIER P/N	ALTEC PN	PAGE	SUPPLIER P/N	ALTEC PN	PAGE	SUPPLIER P/N	ALTEC PN	PAGE	SUPPLIER P/N	ALTEC PN	PAGE
PEJM-SD-46/34	970346295	65	PLJ8BD-38/30	970346053	66	QT20-CH-XL	970551344	60	SEL2-KH	970345835	62
PEJM-SD-48/30	970346272	65	PLJ8BD-38/32	970259007	66	QT20-DB-2XL	970351352	60	SEL2-KH	970345831	62
PEJM-SD-48/32	970346284	65	PLJ8BD-38/34	970346122	66	QT20-DB-3XL	970551353	60	SEL2-KH	970345832	62
PEJM-SD-48/34	970346296	65	PLJ8BD-40/30	970346054	66	QT20-DB-L	970551350	60	SEL2-KH	970345833	62
PEJM-SD-50/30	970346273	65	PLJ8BD-40/32	970346088	66	QT20-DB-M	970551348	60	SEL2-NV	970098667	62
PEJM-SD-50/32	970346285	65	PLJ8BD-40/34	970346123	66	QT20-DB-XL	970551351	60	SEL2-NV	970345847	62
PEJM-SD-50/34	970346297	65	PLJ8BD-42/30	970346055	66	QT32-CH-2XL	970567212	60	SEL2-NV	970098669	62
PEJWSD-10	970567551	71	PLJ8BD-42/32	970346089	66	QT32-CH-3XL	970567213	60	SEL2-NV	970098670	62
PEJWSD-10/30	970346301	65	PLJ8BD-42/34	970346124	66	QT32-CH-4XL	970567214	60	SEL2-NV	970110947	62
PEJWSD-10/32	970346312	65	PLJ8BD-44/30	970346056	66	QT32-CH-L	970567210	60	SEL2-NV	970127686	62
PEJWSD-10/34	970346323	65	PLJ8BD-44/32	970346090	66	QT32-CH-M	970567209	60	SEL2-NV	970098663	62
PEJWSD-11	970567552	71	PLJ8BD-44/34	970346125	66	QT32-CH-XL	970567211	60	SEL2-NV	970345841	62
PEJWSD-12	970567553	71	PLJ8BD-46/30	970346057	66	QT32-DB-4XL	970551354	60	SEL2-NV	970345842	62
PEJWSD-12/30	970346302	65	PLJ8BD-46/32	970346091	66	QT32-TN-2XL	970567218	60	SEL2-NV	970345843	62
PEJWSD-12/32	970346313	65	PLJ8BD-46/34	970346126	66	QT32-TN-3XL	970567219	60	SEL2-OR	970567313	62
PEJWSD-12/34	970346324	65	PLJ8BD-48/30	970346058	66	QT32-TN-4XL	970567220	60	SEL2-OR	970098672	62
PEJWSD-13	970567554	71	PLJ8BD-48/32	970346092	66	QT32-TN-L	970567216	60	SEL2-OR	970098673	62
PEJWSD-14	970567555	71	PLJ8BD-48/34	970346127	66	QT32-TN-M	970567215	60	SEL2-OR	970098674	62
PEJWSD-14/30	970346303	65	PLJ8BD-50/30	970346059	66	QT32-TN-XL	970567217	60	SEL2-OR	970346684	62
PEJWSD-14/32	970346314	65	PLJ8BD-50/32	970346093	66	SEH2NV	970567486	68	SEL2-OR	970345854	62
PEJWSD-14/34	970346325	65	PLJ8BD-50/34	970346128	66	SEH2NV	970567469	68	SEL2-OR	970345855	62
PEJWSD-15	970567556	71	PLW2		65	SEH2NV	970567470	68	SEL2-OR	970345851	62
PEJWSD-16	970567557	71	PMJ5DD-10	970567572	71	SEH2NV	970567471	68	SEL2-OR	970345852	62
PEJWSD-16/30	970346304	65	PMJ5DD-11	970567573	71	SEH2NV	970567472	68	SEL2-OR	970345853	62
PEJWSD-16/32	970346315	65	PMJ5DD-12	970567574	71	SEH2NV	970567463	68	SET8-GY	970567314	62
PEJWSD-16/34	970346326	65	PMJ5DD-13	970567575	71	SEH2NV	970567464	68	SET8-GY	970567315	62
PEJWSD-17	970567558	71	PMJ5DD-14	970567576	71	SEH2NV	970567465	68	SET8-GY	970098626	62
PEJWSD-18	970567559	71	PMJ5DD-15	970567577	71	SEH2NV	970567466	68	SET8-GY	970258993	62
PEJWSD-18/30	970346305	65	PMJ5DD-16	970567578	71	SEH2NV	970567467	68	SET8-GY	970109828	62
PEJWSD-18/32	970346316	65	PMJ5DD-17	970567579	71	SEH2NV	970567468	68	SET8-GY	970567316	62
PEJWSD-18/34	970346327	65	PMJ5DD-18	970567580	71	SEH4-CH	970567449	68	SET8-GY	970567317	62
PEJWSD-19	970567560	71	PMJ5DD-19	970567581	71	SEH4-CH	970567450	68	SET8-GY	970567318	62
PEJWSD-20	970567561	71	PMJ5DD-20	970567582	71	SEH4-CH	970567451	68	SET8-GY	970567319	62
PEJWSD-20/30	970346306	65	PMJ5DD-21	970567583	71	SEH4-CH	970567452	68	SET8-GY	970567320	62
PEJWSD-20/32	970346317	65	PMJ5DD-22	970567584	71	SEH4-CH	970567453	68	SET8-NV	970098631	62
PEJWSD-20/34	970346328	65	PMJ5DD-23	970567585	71	SEH4-CH	970567454	68	SET8-NV	970098638	62
PEJWSD-21	970567562	71	PMJ5DD-24	970567586	71	SEH4-CH	970567455	68	SET8-NV	970098646	62
PEJWSD-22	970567563	71	PMJ5DD-4	970567566	71	SEH4-CH	970567456	68	SET8-NV	970098649	62
PEJWSD-22/30	970346307	65	PMJ5DD-5	970567567	71	SEH4-CH	970567359	68	SET8-NV	970110946	62
PEJWSD-22/32	970346318	65	PMJ5DD-6	970567568	71	SEH4-CH	970567457	68	SET8-NV	970127681	62
PEJWSD-22/34	970346329	65	PMJ5DD-7	970567569	71	SEH4-CH	970567458	68	SET8-NV	970567321	62
PEJWSD-23	970567564	71	PMJ5DD-8	970567570	71	SEH4-CH	970567459	68	SET8-NV	970567322	62
PEJWSD-24	970567565	71	PMJ5DD-9	970567571	71	SEH4-CH	970567460	68	SET8-NV	970567323	62
PEJWSD-24/30	970346308	65	PMU2		65	SEH4-CH	970567461	68	SET8-NV	970567324	62
PEJWSD-24/32	970346319	65	PMU2NV-40/32	970289097	65	SEH4-CH	970567462	68	SLP2-NV	970567265	61
PEJWSD-24/34	970346330	65	PMU2NV-42/32	970287605	65	SEH4-NV	970567435	68	SLP2-NV	970567266	61
PEJWSD-4	970567545	71	PMW2		65	SEH4-NV	970567436	68	SLP2-NV	970567267	61
PEJWSD-4/30	970346298	65	QT11-CH	970567593	71	SEH4-NV	970567437	68	SLP2-NV	970567268	61
PEJWSD-4/32	970346309	65	QT11-CH	970567594	71	SEH4-NV	970567438	68	SLP2-NV	970567269	61
PEJWSD-4/34	970346320	65	QT11-CH	970567595	71	SEH4-NV	970567439	68	SLP2-NV	970567270	61
PEJWSD-5	970567546	71	QT11-CH	970567596	71	SEH4-NV	970567440	68	SLP2-NV	970567271	61
PEJWSD-6	970567547	71	QT11-CH	970567597	71	SEH4-NV	970567441	68	SLP2-NV	970567272	61
PEJWSD-6/30	970346299	65	QT11-CH	970567598	71	SEH4-NV	970567442	68	SLP8-NV	970567281	61
PEJWSD-6/32	970346310	65	QT11-DB	970567587	71	SEH4-NV	970567358	68	SLP8-NV	970567282	61
PEJWSD-6/34	970346321	65	QT11-DB	970567588	71	SEH4-NV	970567443	68	SLP8-NV	970567283	61
PEJWSD-7	970567548	71	QT11-DB	970567589	71	SEH4-NV	970567444	68	SLP8-NV	970567284	61
PEJWSD-8	970567549	71	QT11-DB	970567590	71	SEH4-NV	970567445	68	SLP8-NV	970567285	61
PEJWSD-8/30	970346300	65	QT11-DB	970567591	71	SEH4-NV	970567446	68	SLP8-NV	970567286	61
PEJWSD-8/32	970346311	65	QT11-DB	970567592	71	SEH4-NV	970567447	68	SLP8-NV	970567287	61
PEJWSD-8/34	970346322	65	QT12-DB-2XL	970567230	60	SEH4-NV	970567448	68	SLP8-NV	970567288	61
PEJWSD-9	970567550	71	QT12-DB-3XL	970567231	60	SEL2-GY	970345828	62	SLU8-KH	970567325	63
PLJ8BD-28/30	970346049	66	QT12-DB-4XL	970567232	60	SEL2-GY	970345827	62	SLU8-KH	970345794	63
PLJ8BD-28/32	970346083	66	QT12-DB-L	970567228	60	SEL2-GY	970345826	62	SLU8-KH	970345793	63
PLJ8BD-28/34	970346117	66	QT12-DB-M	970567227	60	SEL2-GY	970345829	62	SLU8-KH	970345795	63
PLJ8BD-30/30	970346050	66	QT12-DB-XL	970567229	60	SEL2-GY	970152157	62	SLU8-KH	970345796	63
PLJ8BD-30/32	970346084	66	QT12-TN-2XL	970567224	60	SEL2-GY	970345824	62	SLU8-KH	970345792	63
PLJ8BD-30/34	970346118	66	QT12-TN-3XL	970567225	60	SEL2-GY	970345830	62	SLU8-KH	970567326	63
PLJ8BD-32/30	970346051	66	QT12-TN-4XL	970567226	60	SEL2-GY	970345821	62	SLU8-KH	970345789	63
PLJ8BD-32/32	970346085	66	QT12-TN-L	970567222	60	SEL2-GY	970345822	62	SLU8-KH	970345790	63
PLJ8BD-32/34	970346119	66	QT12-TN-M	970567221	60	SEL2-GY	970345823	62	SLU8-KH	970345791	63
PLJ8BD-34/30	970346052	66	QT12-TN-XL	970567223	60	SEL2-KH	970345838	62	SLU8-KH	970567327	63
PLJ8BD-34/32	970346086	66	QT20-CH-2XL	970551345	60	SEL2-KH	970345837	62	SLU8-LB	970567328	63
PLJ8BD-34/34	970346120	66	QT20-CH-3XL	970551346	60	SEL2-KH	970345836	62	SLU8-LB	970345802	63
PLJ8BD-36/30	970264152	66	QT20-CH-4XL	970551347	60	SEL2-KH	970345839	62	SLU8-LB	970345801	63
PLJ8BD-36/32	970346087	66	QT20-CH-L	970551343	60	SEL2-KH	970345840	62			
PLJ8BD-36/34	970346121	66	QT20-CH-M	970551326	60	SEL2-KH	970345834	62			

PRODUCT INDEX
BY SUPPLIER ITEM NUMBER

USA: 1-877-GO ALTEC
(1-877-462-5832)

www.alteconnect.com



BULWARK

SUPPLIER P/N	ALTEC PN	PAGE
SLU8-LB	970345803	63
SLU8-LB	970345804	63
SLU8-LB	970345800	63
SLU8-LB	970567329	63
SLU8-LB	970345797	63
SLU8-LB	970345798	63
SLU8-LB	970345799	63
SLU8-LB	970345800	63
SLU8-NV	970567330	63
SLU8-NV	970346178	63
SLU8-NV	970346179	63
SLU8-NV	970346180	63
SLU8-NV	970346181	63
SLU8-NV	970346182	63
SLU8-NV	970567331	63
SLU8-NV	970346183	63
SLU8-NV	970346184	63
SLU8-NV	970346185	63
SLU8-NV	970567332	63
SLU8-OR	970567333	63
SLU8-OR	970345818	63
SLU8-OR	970345817	63
SLU8-OR	970345819	63
SLU8-OR	970345820	63
SLU8-OR	970345816	63
SLU8-OR	970567334	63
SLU8-OR	970345813	63
SLU8-OR	970345814	63
SLU8-OR	970345815	63
SLU8-OR	970567335	63
SLW2-KH	970567336	63
SLW2-KH	970567337	63
SLW2-KH	970341959	63
SLW2-KH	970341975	63
SLW2-KH	970567338	63
SLW2-KH	970567339	63
SLW2-KH	970567340	63
SLW2-KH	970567341	63
SLW2-KH	970567342	63
SLW2-KH	970567343	63
SLW2-KH	970567344	63
SLW2-LB	970567345	63
SLW2-LB	970567346	63
SLW2-LB	970567347	63
SLW2-LB	970567348	63
SLW2-LB	970567349	63
SLW2-LB	970567350	63
SLW2-LB	970567351	63
SLW2-LB	970567352	63
SLW2-LB	970567353	63
SLW2-LB	970567354	63
SLW2-LB	970567355	63
SLW2-NV	970567356	63
SLW2-NV	970567357	63
SLW2-NV	970341985	63
SLW2-NV	970269647	63
SLW2-NV	970567360	63
SLW2-NV	970567361	63
SLW2-NV	970567362	63
SLW2-NV	970567363	63
SLW2-NV	970567364	63
SLW2-NV	970567365	63
SLW2-NV	970567366	63
SMH2NV	970567473	68
SMH2NV	970567474	68
SMH2NV	970567475	68
SMH2NV	970567476	68
SMH2NV	970567477	68
SMH2NV	970567478	68
SMH2NV	970567933	68
SMH2NV	970567479	68
SMH2NV	970567480	68
SMH2NV	970567481	68

BULWARK

SUPPLIER P/N	ALTEC PN	PAGE
SMH2NV	970567482	68
SMH6-NV-2XL	970567494	69
SMH6-NV-2XL-LONG	970567498	69
SMH6-NV-3XL	970567495	69
SMH6-NV-3XL-LONG	970567599	69
SMH6-NV-L	970567492	69
SMH6-NV-L-LONG	970567496	69
SMH6-NV-M	970567491	69
SMH6-NV-M-LONG	970567936	69
SMH6-NV-S	970567490	69
SMH6-NV-XL	970567493	69
SMH6-NV-XL-LONG	970567497	69
SMK2HV	970346186	67
SMK2HV	970346187	67
SMK2HV	970346188	67
SMK2HV	970346189	67
SMK2HV	970346190	67
SMK2HV	970346191	67
SMK2HV	970346192	67
SMK2HV	970568106	67
SML2-GY	970567233	61
SML2-GY	970567234	61
SML2-GY	970567235	61
SML2-GY	970567236	61
SML2-GY	970567237	61
SML2-GY	970567238	61
SML2-GY	970567239	61
SML2-GY	970567240	61
SML2-KH	970567241	61
SML2-KH	970567242	61
SML2-KH	970567243	61
SML2-KH	970567244	61
SML2-KH	970567245	61
SML2-KH	970567246	61
SML2-KH	970567247	61
SML2-KH	970567248	61
SML2-KH	970567249	61
SML2-NV	970567250	61
SML2-NV	970567251	61
SML2-NV	970567252	61
SML2-NV	970567253	61
SML2-NV	970567254	61
SML2-NV	970567255	61
SML2-NV	970567256	61
SMP2-KH	970567257	61
SMP2-KH	970567258	61
SMP2-KH	970567259	61
SMP2-KH	970567260	61
SMP2-KH	970567261	61
SMP2-KH	970567262	61
SMP2-KH	970567263	61
SMP2-KH	970567264	61
SMP8-KH	970567273	61
SMP8-KH	970567274	61
SMP8-KH	970567275	61
SMP8-KH	970567276	61
SMP8-KH	970567277	61
SMP8-KH	970567278	61
SMP8-KH	970567279	61
SMP8-KH	970567280	61
SMT2-GY	970567289	62
SMT2-GY	970567290	62
SMT2-GY	970567291	62
SMT2-GY	970567292	62
SMT2-GY	970567293	62
SMT2-GY	970567294	62
SMT2-GY	970567295	62
SMT2-GY	970567296	62
SMT2-KH	970567297	62
SMT2-KH	970567298	62
SMT2-KH	970567299	62
SMT2-KH	970567300	62
SMT2-KH	970567301	62

BULWARK

SUPPLIER P/N	ALTEC PN	PAGE
SMT2-KH	970567302	62
SMT2-KH	970567303	62
SMT2-KH	970567304	62
SMT2-NV	970567305	62
SMT2-NV	970567306	62
SMT2-NV	970567307	62
SMT2-NV	970567308	62
SMT2-NV	970567309	62
SMT2-NV	970567310	62
SMT2-NV	970567311	62
SMT2-NV	970567312	62
SMU2-KH	970567367	63
SMU2-KH	970567368	63
SMU2-KH	970567369	63
SMU2-KH	970567370	63
SMU2-KH	970567371	63
SMU2-KH	970567372	63
SMU2-KH	970567373	63
SMU2-KH	970567374	63
SMU2-KH	970567375	63
SMU2-KH	970567376	63
SMU2-KH	970567377	63
SMU2-LB	970567378	63
SMU2-LB	970567379	63
SMU2-LB	970567380	63
SMU2-LB	970567381	63
SMU2-LB	970567382	63
SMU2-LB	970567383	63
SMU2-LB	970567384	63
SMU2-LB	970567385	63
SMU2-LB	970567386	63
SMU2-LB	970567387	63
SMU2-LB	970567388	63
SMU2-NV	970567389	63
SMU2-NV	970567390	63
SMU2-NV	970567391	63
SMU2-NV	970287546	63
SMU2-NV	970567392	63
SMU2-NV	970567393	63
SMU2-NV	970567394	63
SMU2-NV	970567395	63
SMU2-NV	970567396	63
SMU2-NV	970567397	63
SMU2-NV	970567398	63
SMZ6-NV-2XL	970567487	69
SMZ6-NV-3XL	970567488	69
SMZ6-NV-4XL	970567489	69
SMZ6-NV-L	970567485	69
SMZ6-NV-M	970567484	69
SMZ6-NV-S	970567483	69
SMZ6-NV-XL	9705628997	69

BURNDY

SUPPLIER P/N	ALTEC PN	PAGE
ALFLUIDGAL	970216407	364
ALFLUIDQT	970216406	364
BTW150750	970358673	303
BTW1575F12	970439469	303
BTW30150	970358669	303
CUTTER	970366495	343
CUTTER DIES	970366615	345
DIE ADAPTER	970366641	346
FORCEGAUGE12-15	970358665	364
GP10	970111234	364
HCCCUAL	970358652	321
HCCGUY	970358660	321
HCCSOL	970637177	321
HIW716ENF	970203368	362
HIW716MAG	970203368	362
HIW716MAGKIT1	970637135	362
HIW716MAGKIT2	970637136	362
HIW716MAGKIT3	970637137	362
HIW716MAGKIT4	970637138	362

BURNDY

SUPPLIER P/N	ALTEC PN	PAGE
HIW716MAGKIT5	970637139	362
KD6-13	970006365	343
LPHTBIT111612HC	970637161	363
LPHTBIT111612SC	970637166	363
LPHTBIT111618	970637156	363
LPHTBIT111618B	970298022	363
LPHTBIT111618HC	970637164	363
LPHTBIT111618R	970637147	363
LPHTBIT111624D	970298045	363
LPHTBIT111624R	970637151	363
LPHTBIT11812HC	970637163	363
LPHTBIT11824D	970637143	363
LPHTBIT11824R	970637154	363
LPHTBIT1218	970637155	363
LPHTBIT131612HC	970637162	363
LPHTBIT131612SC	970637167	363
LPHTBIT131618	970637157	363
LPHTBIT131618B	970298043	363
LPHTBIT131618HC	970637165	363
LPHTBIT131618R	970637149	363
LPHTBIT131624	970637159	363
LPHTBIT131624D	970298047	363
LPHTBIT131624R	970637152	363
LPHTBIT151618	970637158	363
LPHTBIT151618B	970298044	363
LPHTBIT151618R	970637150	363
LPHTBIT151624D	970298048	363
LPHTBIT151624R	970637153	363
LPHTBIT3418D	970298041	363
LPHTBIT3418R	970637148	363
LPHTBIT3424D	970637142	363
LPHTBIT5818D	970298039	363
LPHTBIT5818R	970637146	363
LPHTBIT5824D	970637141	363
LPHTBIT7818D	970637140	363
LPHTBIT91612HC	970637160	363
LPHTBIT91618R	970637144	363
LPHY750XT	970216402	362
MAGHOLSTER	970640808	362
MD6	900099875	302
MD66	970637131	302
MD68	900006688	302
MD7	900076543	302
MD76	970637132	302
MD78	970015011	302
OH25	970020544	303
OUR840	970112226	303
P39ART	970118842	346
P39RT	970366637	346
P40ART	970366642	346
P40RT	970366638	346
P44ART	970020545	346
P44RT	970088795	346
P46RT	970366639	346
P724	970366640	346
PAT46CLWS-LI	970637179	321
PAT46LW-LI	970637180	321
PAT46LWS-LI	970637178	321
PAT750-LI	970298014	321
PATCUT129-LI	970298011	321
PATCUT2156-LI	970637181	321
PATHCC10-18V	970637176	321
PATHCC10ACSR-18V	970358645	321
PKR	970366643	346
PN	970224829	346
PT11018	970216405	364
PT29900-10	970124704	364
PT29900-15	970216409	364
PT29900-25	970216410	364
PT29901-10	970216411	364
PT29901-15	970216412	364

BURNDY

BURNDY

BURNDY

CAPITAL SAFETY

SUPPLIER P/N	ALTEC PN	PAGE	SUPPLIER P/N	ALTEC PN	PAGE	SUPPLIER P/N	ALTEC PN	PAGE	SUPPLIER P/N	ALTEC PN	PAGE
PT29901-25	970216413	364	U32RT	970345201	345	W-249	970336290	343	1001387	970637225	43
PT93	970216416	364	U34ART	970104929	342	W-249	900010176	376	1001388	970637226	43
PT94	970216415	364	U34ART	970104929	345	W-28K	970366495	343	1001389	970637227	43
RCC336	970269756	303	U34RT	900034000	342	W-28K	970015446	376	1001390	970637228	43
RCC556	970105612	303	U34RT	900034000	345	W-687	970075376	343	1001391	970637229	43
RCC954ACSR1K	970358666	303	U36ART	900050561	342	W-702	970105475	343	1001392	970637204	43
TEST DIES	970366616	345	U36ART	900050561	345	W-BG	970280715	343	1001393	970637205	43
U-161	970366587	344	U36RT	900050561	342	W-BG	970026993	376	1001394	970637206	43
U-162	900016200	344	U36RT	970366610	345	W-C	970280714	343	1001395	970637207	43
U-163	970086587	344	U-373	970366601	344	W-C	900010167	376	1001396	970637208	43
U-164	970366588	344	U39ART2	970104931	345	WK-840	970006365	376	1001397	970637209	43
U-165	900001650	344	U39ART-2	970104931	342	W-K840	970280711	343	1001398	970637210	43
U-166	970366589	344	U39RT	900007379	342	W-L	970366494	343	1001399	970637211	43
U-167	970366590	344	U39RT	900007379	345	W-O	970366486	343	1001400	970637212	43
U-168	970366591	344	U3CRT	970366607	345	W-O	68300116	376	1001401	970637213	43
U-169	970344255	344	U-468	970366602	344	Y10AC9	970216403	364	1001402	970637214	43
U-170	970344256	344	U-490	970063262	344	Y35	970069834	302	1001403	970637215	43
U1CRT	970570958	342	U4CABT	970366457	342	Y35-2	970105606	302	1001404	970637216	43
U1CRT	970570958	345	U4CABT	970366457	345	Y60LW	970389692	364	1102000		41
U-203	970366592	344	U4CRT	970189364	342	Y60LWCASE	970637169	364	1102090		41
U-236	970366593	344	U4CRT	970189364	345	Y60LWLS	970389693	364	1102950	970325386	41
U-237	970366594	344	U5CRT	970189363	342	Y750CHSXT	970457098	302	1103321		41
U-238	970366595	344	U5CRT	970189363	345	Y750HSXT	970105607	302	1107807		41
U-239	970366596	344	U-654	970005624	344	YACCASE	970216408	364	1110100	970475111	43
U-242	970260757	344	U-655	970005627	344				1110101	900011101	43
U-243	970366597	344	U-658	970366603	345				1110102	900011112	43
U-245	970148554	344	U-659	970366604	345				1110103	900011103	43
U-247	970366598	344	U6CABT	970366455	342				1110600		41
U-248	970148553	344	U6CART	970366608	345				1110810	970325387	41
U-249	970031469	344	U-705	970031471	345				1110811	970325388	41
U-251	970107091	344	U-788	970114254	345				1110812	970325390	41
U-252	970366599	344	U8CABT	970366454	342				1110840	900011108	43
U25ART	970146951	342	U8CABT	970366454	345				1110841	900011109	43
U25ART	970366611	345	U-998	970366605	345				1110842	900011107	43
U25RT	970350323	342	U-BG	970366583	344				1110890	970250275	43
U25RT	970350323	345	U-C	970366584	344				1110891	970067384	43
U-261	970005619	344	U-D	970059695	344				1110892	970250276	43
U26ART	970189221	342	U-D3	970098806	344				1112126		41
U26ART	970189221	345	U-E	970098807	344				1113000	970325356	42
U26RT	970345200	342	U-F	970366585	344				1113001	970325359	41-43
U26RT	970345200	345	U-H	970366586	344				1113004	970294631	41-43
U27ART	970130845	342	UK840T	970366606	345				1113007	970294635	42
U27ART	970366612	345	U-L	970107092	344				1113010	970294637	42
U27RT	970366458	342	U-M	900096173	344				1113013	970325361	42
U27RT	970366458	345	U-N	900080002	344				1113090	970325373	42
U28ART	970130842	342	U-O	970098786	344				1113091	970325374	42
U28ART	970130842	345	U-R	970107094	344				1113094	970325375	42
U28RT	900035783	342	W-161	970366480	343				1113100	970325376	42
U28RT	900035783	345	W-161	900001614	376				1113103	970325377	42
U29ART	900035786	342	W-162	970366481	343				1113190	970325362	42
U29ART	900035786	345	W-162	900010170	376				1113191	970325363	42
U29RT	900035784	342	W-163	970366482	343				1113192	970325364	42
U29RT	900035784	345	W-163	900001616	376				1113193	970325365	42
U2CABT	900035780	342	W-164	970366483	343				1113194	970325371	42
U2CABT	900035780	345	W-164	900010177	376				1113215	970325379	42
U2CRT	900035778	342	W-165	900000569	343				1113216	970325380	42
U2CRT	900035778	345	W-166	970366484	343				1113217	970325381	42
U-305	970366600	344	W-166	900010173	376				1113218	970325382	42
U30ART	970158510	342	W-167	970075378	343				1113219	970325383	42
U30ART	970158510	345	W-171	970366485	343				1113357	970640786	42
U30RT	970158508	342	W-236	970366488	343				1113358	970640787	42
U30RT	970158508	345	W-237	970366489	343				1113368	970640788	42
U-316	970086603	344	W-237	900010179	376				1113369	970640789	42
U-317	970005628	344	W-238	970366490	343				1150914	970363092	45
U31ART	970130840	342	W-239	970366491	343				1150915	970363093	45
U31ART	970130840	345	W-239	900010180	376				1150916	970363117	45
U31RT	970119978	342	W-241	970344509	343				1150917	970363128	45
U31RT	970366609	345	W-243	970366492	343				1204057	970277099	45
U-321	970075446	344	W-243	900010174	376				1204058	970277098	45
U-327	970119522	344	W-245	970057447	343				1242551	970325394	44
U32ART	970366613	342	W-247	970366493	343				1244306	970232685	44
U32ART	970366613	345	W-247	900010175	376				1244409	970152035	44
U32RT	970345201	342	W-248	970100610	343				1244610	970325392	44

PRODUCT INDEX
BY SUPPLIER ITEM NUMBER

USA: 1-877-GO ALTEC
(1-877-462-5832)

www.alteccconnect.com

CAMPBELL

SUPPLIER P/N	ALTEC PN	PAGE
1005505	970516576	555
7220214	970516570	253
7220214	970516570	555
7222213	970516571	253
7222213	970516571	555
7222214	970516572	253
7222214	970516572	555
7380300	970498440	253
7380303	970637557	253
5410405	970640814	250
5410505	970640815	250
5410605	970640816	250
5410695	970637581	250
5410705	970640817	250
5410805	970640818	250
5410895	970637582	250
5411005	970640819	250
5411095	970637583	250
5411205	970640820	250
5411295	970637584	250
5411405	970640821	250
5411495	970637585	250
5411605	970640822	250
5411695	970637586	250
5411805	970640823	250
5412005	970640824	250
5412095	970637587	250
5412205	970640825	250
5412295	970637588	250
5412405	970640826	250
5412495	970637589	250
5412805	970640827	250
5413205	970640828	250
5413295	970637590	250

CAPITAL SAFETY

SUPPLIER P/N	ALTEC PN	PAGE
1001379	970637217	43
1001380	970637218	43
1001381	970637219	43
1001382	970637220	43
1001383	970637221	43
1001384	970637222	43
1001385	970637223	43
1001386	970637224	43



CAPITAL SAFETY

SUPPLIER P/N	ALTEC P/N	PAGE
1244611	970206097	44
1244631	970325395	44
1244760	970325392	44
3101001	70421244	45
3101527	970540785	46
3101575	970640784	46
3305040	970434713	46
3305041	970434714	46
3305042	970434715	46
3305043	970434716	46
3305044	970434717	46
3305045	970434718	46
3400900	970363129	45
5000335	970150645	45
9501403	970186621	45

COLUMBUS
MCKINNON

SUPPLIER P/N	ALTEC P/N	PAGE
6140	970216397	116
6240	970216398	116
6250	900706250	116
6260	970200091	116
M702	970366350	252
M703	970366351	252
M703A	970366356	252
M704	970366352	252
M704A	970366357	252
M705	970366353	252
M705A	970366358	252
M706	970366354	252
M706A	970366359	252
MC649	970366345	252
MC650	970366346	252
MC651	970366347	252
MC652	970366348	252
MC654	970366349	252
115DB	970080122	219
115SB	970080120	219
250A	970113132	220
250CA	970113135	220
250DA	970040525	220
250DHA	970113140	220
300A	970040531	220
300CA	970091801	220
300DA	900700300	220
300DHA*	970091804	220
322B	970021966	220
322CB	970113152	220
322DB*	970072840	220
322DHB*	970091641	220
344B	970021965	220
344CB	970113146	220
344DB*	970107369	220
344DHB*	970113149	220
434WNB	970080124	219
6000A	900096159	219
6000CA	970113269	219
6000DA*	970040528	219
AG	900700100	218
ATG	900700123	218
ATGI	970105473	218
BAN07505	970648980	219
BAN07510	970648983	219
BAN07515	970648985	219
BAN07520	970648986	219
BAN15005	970648988	219
BAN15010	970648991	219
BAN15015	970648994	219
BAN15020	970648995	219
BAN30005	970648997	219
BAN30010	970648998	219

COLUMBUS
MCKINNON

SUPPLIER P/N	ALTEC P/N	PAGE
BAN30015	970648999	219
BAN30020	970649000	219
BAN60005	970649003	219
BAN60010	970649004	219
BAN60015	970649005	219
BAN60020	970649010	219
FTG	900700130	218
LMG4500	900004500	218
LMG4501	970062695	218
LMG4600	970043133	218
LMG4601	970080827	218
LMG4800	970047914	218
LMG4801	970060000	218
LSB1500B-10	900015010	218
LSB3000B-10	970081033	218
LSB6000B-10	970081038	218
RA15	970072886	219
RA20	900020800	219
RA30	970080115	219
RA40	970080118	219
TB602-10	900060201	218
TB602-5	900060205	218
TB603-10	970109683	218
TB603-5	970109680	218
ZG-6	900700140	218

CONOCO

SUPPLIER P/N	ALTEC P/N	PAGE
SUPER-STAM#2	9900025	165

CRESCENT / APEX

SUPPLIER P/N	ALTEC P/N	PAGE
2010	970637611	270
192-CWWS4	970637637	273
192-CSWS11	970637636	273
507CVN	970637618	271
508CVN	970637619	271
5428CVN	970637614	271
6547CVN	970637617	271
9533N	970637638	273
AC110	970637623	272
AC112	970637624	272
AC115*	970637625	272
AC118*	970637626	272
AC124*	970637627	272
AC18	970637622	272
AC3	970637633	272
AT10SPUD	970637631	272
AT115SPUD	970637632	272
AT210BK	970637629	272
AT212BK	970637630	272
AT28BK	970637628	272
C10SV	970637640	273
CCA20509	970637620	271
CCA5428	970637615	271
CCA6548	970637616	271
CLP5SET	970637643	273
CTK148MP	970637639	273
HL120P	970498459	271
R212CV	970498457	271
R216CV	970498458	271

CROSBY

SUPPLIER P/N	ALTEC P/N	PAGE
29741	23421007	535
108038	970152119	253
108065	900099578	253
108127	900099579	253
108225	970157619	253
109037	41520154	534
297217	23421010	534
297217	23421010	535

CROSBY

SUPPLIER P/N	ALTEC P/N	PAGE
297413	23421007	534
297618	813000308	534
599533	70020291	534
1018446	900099580	253
1018446	900099580	534
1018464	900710184	253
1018464	900710184	534
1018482	900099581	253
1018482	900099581	534
1018507	900099582	253
1018507	900099582	534
1018523	23421005	253
1018523	23421005	534
1096562	23421048	535

DCD DESIGN &
MANUFACTURING

SUPPLIER P/N	ALTEC P/N	PAGE
23375-030	970157566	248

DILLON

SUPPLIER P/N	ALTEC P/N	PAGE
30006-0027	970099329	536
30006-0035	970094051	536
30006-0084	970012731	536
30006-0100	900099868	536
36188-0032	970228968	536
36190-0053	970060779	536

ECHO

SUPPLIER P/N	ALTEC P/N	PAGE
103942143	900000521	575
103942144	900000522	575
WP-1000	900099831	384

EDWARDS GLOVE

SUPPLIER P/N	ALTEC P/N	PAGE
500G- 11/XL	970158440	102
500G-10/L	970158437	102
500G-9/M	970158435	102

FEDERAL SIGNAL

SUPPLIER P/N	ALTEC P/N	PAGE
251500	68451039	188
251500	68451039	188
320772	68455024	187
320782	970050659	187
320792	970011275	187
320882	970247006	187
320892	970466026	187
330104	68455025	187
330104	68455025	187
448330	811001231	188
620122	068435069-	189
620502	900088954	189
210238-S	970392464	169, 189
210238-W	970392468	169, 189
210239-S	970392466	169, 189
210239-W	970392469	169, 189
210240-S	970392467	169, 189
210240-W	970392470	169, 189
210331SSG	60870026	169, 189
212660-02SB	970162088	188
220250-02	970571088	188
220260-02	970571105	188
250121-02	68451059	188
251121-02	810000540	188
251821-02	68451065	188
252650-02SC	970041444	187

FEDERAL SIGNAL

SUPPLIER P/N	ALTEC P/N	PAGE
272650-02	970392461	187
331105-SB	705201298	187
331105-SB	705201298	187
416200-22	970290180	189
416200-44	970570324	189
416200-55	970346659	189
420209-02	68451081	188
420221-02	68451218	188
443112-02	893914080	188
448112-02	68451058	188
449112-02	705201079	188
450112-02	893911970	187
454201-02SC	970127407	187
CAMSET56-NTSC-2	970157236	147
CAMSET56-NTSC-2	970157236	147, 189
CAMSET70-NTSC4B	970329767	147, 189
COM120-ON-530SW	970560112	189
COMCL15K-530SW	970566322	189
IPX302-2	970162089	188
IPX602-A	970339965	188
IPX620-WA	970339969	188
LPX45D-00033	970392450	187
LPX53D-00042	970392815	187
LPX61D-00027	970392817	187
MPS1200-AA	970570322	188
MPS300-A	970363839	188
MPS300-W	970410999	188
MPS600-AA	970346655	188
MPS600-WW	970346654	188

GEARWRENCH /
APEX

SUPPLIER P/N	ALTEC P/N	PAGE
84546	970637558	373
84547	970637559	373
84548	970637560	373
84549	970637561	373
84550	970637562	373
84551	970637563	373
84552	970637564	373
84553	970637565	373
84554	970637566	373
84555	970637567	373
84556	970637568	373
84557	970637569	373
84558	970637570	373
82220	970637652	274
82248	970637653	274
82305	970637648	274
82765	970637612	270
8908D	970637613	270

GENERAL
MACHINE PRODUCTS

SUPPLIER P/N	ALTEC P/N	PAGE
1008	900001008	505
1051	970077142	508
1368	900001368	493
3165	900003165	508
06409	900006409	140
6867	900006867	493
07280	900007280	140
07886	900007886	509
10109	900000277	494
10110	900000278	494
10111	900000279	494
10112	900000280	494
10113	900000281	494
10114	900000282	494
10115	900000283	494
10116	900000284	494
10117	900000285	494

GENERAL
MACHINE PRODUCTS

GENERAL
MACHINE PRODUCTS

GENERAL
MACHINE PRODUCTS

GENERAL
MACHINE PRODUCTS

SUPPLIER P/N	ALTEC P/N	PAGE
10118	900000286	494
10119	900000287	494
10120	900000288	494
10121	900000289	494
10122	900000290	494
10123	900000291	494
10124	900000293	494
10125	900000294	494
10126	900000313	494
10127	900000314	494
10128	900000315	494
10129	900000316	494
10130	900000317	494
10142	900010142	494
10143	900010143	494
10144	900010144	494
10145	900010145	494
10146	900010146	494
10152	900070407	493
10153	900070408	493
10154	900070409	493
10155	900070410	493
10156	900070411	493
10157	900070412	493
10158	900070413	493
10500	900010500	508
10501	900010501	508
10502	900010502	508
10553	900010553	509
10727	900010727	166
10727	900010727	503
13681	970176856	493
15470	900015470	166
15470	900015470	501
15471	900015471	505
15472	900015472	166
15472	900015472	501
15475	900015475	505
15479	900015479	166
15479	900015479	501
17022	900071022	498
17025	900000319	493
17050	900000320	493
17091	900017091	493
17092	900017092	493
17093	900017093	493
17094	900017094	493
24470	900024470	505
24471	900024471	505
26006	900026006	205
26006	900026006	166
26007	900026007	205
26007	900026007	166
28210	900028210	504
28249	970216633	505
29446	970216444	495
29447	970216445	495
29448	970216420	495
30140	900030140	509
31356	900070438	500
31357	900070439	500
31358	900070440	500
53700	900053700	502
53701	900053701	502
53702	900053702	502
53703	900053703	502
53704	900053704	502
53705	900053705	502
60510	900060510	498
60512	900060512	498
60515	900060515	498
60520	900060520	498
60580	900060580	499
60581	900060581	499

SUPPLIER P/N	ALTEC P/N	PAGE
60582	900060582	499
60583	900060583	499
60584	900060584	499
60585	900060585	499
60586	900060586	499
60587	900060587	499
60590	900060590	499
60591	900060591	499
60592	900060592	499
60593	900060593	499
60596	900060596	499
60597	900060597	499
60598	900060598	499
60599	900060599	499
60600	900060600	499
61510	900000321	498
61512	900000322	498
61515	900000323	498
61520	900000324	498
63540	970040858	496
63541	970040859	496
66050	900066050	504
66051	900066051	504
68592	900068592	497
68593	900068593	497
68595	900068595	497
68596	900068596	497
68597	900070368	497
70001	900070001	499
70002	900070002	499
70003	900070003	499
70004	900070004	499
70005	900070005	499
70006	900070006	499
70007	900070007	499
70008	900070008	499
70009	900070009	499
70125	900070125	509
70136	900070136	497
70136	900070136	507
70137	900070137	497
70138	900070138	497
70139	900070139	497
70140	900070140	497
70151	900070151	493
70152	900070152	493
70153	900070153	493
70154	900070154	493
70155	900070369	493
70156	900070156	493
70157	900070157	493
70175	900070175	140
70188	900070188	502
70190	900070190	508
70191	900070191	502
70202	900070202	503
70274	900070274	205
70274	900070274	166
70276	900070276	205
70276	900070276	166
70277	900070277	205
70277	900070277	166
70278	900070278	205
70278	900070278	166
70283	900070283	499
70284	900070284	499
70285	900070285	499
70298	900070298	498
70299	900070299	498
70300	900070300	498
70327	900070327	140
70329	900070329	503
70338	900070403	501
70351	900070351	166

SUPPLIER P/N	ALTEC P/N	PAGE
70351	900070351	501
70352	900070352	504
70381	900000326	501
70403	970186307	504
70471	900000327	501
70472	900000328	501
70473	900000329	501
70475	900000330	501
70478	900000331	501
70483	900070398	501
70484	900070399	501
70486	900070401	501
70487	900070402	501
70505	970216461	496
70506	970216462	496
70508	970216463	496
70509	970216464	496
70510	970216465	496
70511	970216467	496
70512	970216468	496
70513	970216469	496
70515	970216471	496
70516	970216473	496
70517	970216474	496
70518	970216475	496
70524	900070441	503
70527	970216478	496
70528	970216479	496
70529	970216480	496
70531	970216482	496
70532	970216616	496
70564	900000332	497
70565	900000333	497
70566	900000334	497
70567	900000335	497
70581	900000336	497
70582	900000337	497
70583	900000338	497
70584	900000339	497
70585	900000340	497
70586	900000341	497
70594	970334123	507
70595	970334130	506
70605	900000342	501
70613	970334131	507
70614	970334166	506
70615	970334171	506
70616	970334174	506
70619	970334177	507
70621	970334209	506
70624	970334212	507
70626	970216628	505
70640	900070435	500
70643	900070436	500
70646	900070437	500
70649	970216627	505
70660	900070414	498
70661	900070415	498
70662	900070416	498
70663	900070417	498
70670	900070418	498
70671	900070419	498
70672	900070420	498
70673	900070421	498
70674	900070422	498
70675	900070423	498
70676	900070424	498
70677	900070425	498
70680	900070426	498
70681	900070427	498
70681	900070427	507
70682	900070428	498
70682	970334219	507
70683	900070429	498

SUPPLIER P/N	ALTEC P/N	PAGE
70683	900070429	507
70684	900070434	498
71130	970216630	505
71131	970216634	505
71132	970216635	505
71399	900071399	502
71400	900071400	502
71401	900071401	502
71402	900071402	502
71403	900071403	502
71404	900071404	502
71405	900071405	502
71406	900071406	502
71408	900071408	502
71530	900071530	508
71531	900071531	508
71532	900071532	508
71533	900071533	508
71534	900071534	508
71535	900071535	508
71548	970216618	502
71549	970216619	502
71550	970216620	502
71551	970216621	502
71552	970216622	502
71554	970216623	502
71560	970216624	502
71561	970216625	502
71562	970216626	502
71563	970216632	505
71643	900071643	500
71644	900071644	500
71645	900071645	500
71647	900071647	504
71669	900000343	504
71710	900071710	500
71711	900071711	500
71712	900071712	500
71713	900071713	500
71714	900071714	500
71715	900071715	500
71721	900071721	500
71722	900071722	500
71723	900071723	500
71724	900071724	500
71725	900071725	500
71726	900071726	500
71727	900071727	500
71728	900071728	500
71729	900071729	500
74530	900074530	504
74531	900074531	504
75268	970216636	505
80771	900080771	498
80773	900080773	498
80775	900080775	498
80777	900080777	498
80779	900080779	498
80920	900080920	504
80921	900080921	504
80975	900080975	499
81460	900081460	509
84453	900084453	499
84454	900084454	499
86570	900086570	497
86571	900086571	497
88830	900088830	499
88831	900088831	499
89000	900000344	501
89004	970216417	494
89174	900000345	501
89175	900000347	501
89202	900070370	495

PRODUCT INDEX
BY SUPPLIER ITEM NUMBER

USA: 1-877-GO ALTEC
(1-877-462-5832)

www.alteccconnect.com



GENERAL MACHINE PRODUCTS

SUPPLIER P/N	ALTEC P/N	PAGE
89204	900070371	495
89206	900070372	495
89208	900070373	495
89210	900070374	495
89222	900070375	495
89224	900070376	495
89226	900070377	495
89228	900070378	495
89230	900070379	495
89232	900070381	495
89234	900070382	495
89236	900070383	495
89238	900070384	495
89240	900070385	495
89242	900070386	495
89252	900070387	495
89254	900070388	495
89256	900070389	495
89258	900070390	495
89260	900070391	495
89262	900070392	495
89264	900070393	495
89266	900070394	495
89268	900070395	495
89270	900070396	495
89272	900070397	495
89804	970216446	496
89805	970216447	496
89806	970216453	496
89807	970216454	496
89808	970216455	496
89809	970216456	496
89810	970216457	496
89811	970216458	496
89812	970216459	496
89813	970216460	496
89820	970216477	496
91604	900091604	509
91605	970216638	509
91606	970074294	509

CROSBY

SUPPLIER P/N	ALTEC P/N	PAGE
2000	705201491	199
2020	68435071	199
3000	970105297	199
3067	970051684	199
3100	970097437	199
7901	717330015	199
30001	970262822	199
30002	970294235	199
30003	970286894	199
	970336531	199
	717330018	199
	970193162	199
	900001800	199
	717330034	199
	717330034	199
	970081966	199

GREENLEE

SUPPLIER P/N	ALTEC P/N	PAGE
40180	900099807	377
40275	900099898	377
40317	970006663	377
40377	812640276	377
41120	900039009	377
48254	900048254	377
48313	900048313	377
48371	970014407	377
48538	900099877	377

GREENLEE

SUPPLIER P/N	ALTEC P/N	PAGE
48829	970014416	377
48839	970014414	377
49272	900099943	377
49343	970014415	377
49358	900049358	377
49901	900099890	377
KA12-1/0	900035792	345
KA12-2	900035778	345
KA12-2/0	900035793	345
KA12-250	970103581	345
KA12-3/0	900035794	345
KA12-300	900035787	345
KA12-350	900035788	345
KA12-4	970059695	345
KA12-4/0	970364795	345
KA12-400	900035789	345
KA12-500	900035795	345
KA12-600	900035790	345
KA12-750	900035796	345
KA12-8	970103570	345
KC12-1	970103590	345
KC12-1/0	970103635	345
KC12-1/0	970103635	345
KC12-2	900035778	345
KC12-2/0	970103841	345
KC12-250	900035784	345
KC12-3/0	970103846	345
KC12-300	970103847	345
KC12-300	970103847	345
KC12-350	900035786	345
KC12-350	970364814	345
KC12-350	970364814	345
KC12-4	970103588	345
KC12-4/0	900035783	345
KC12-400	970103848	345
KC12-400	970103848	345
KC12-500	970103849	345
KC12-500	970103849	345
KC12-600	970103851	345
KC12-600	970103851	345
KC12-750	970364817	345
KD12-38	970005613	345
KD12-39	970098812	345
KD12-40	970098813	345
00113	970017288	259
390	970637195	485
392	970329294	485
430	900000064	485
431	900000065	485
435	900000071	485
489	900099583	483
591	900099509	485
591	900099509	487
592	970637196	485
613	900099515	486
614	900099516	486
615	900099518	486
616	900099520	486
617	900099522	486
618	900099524	486
619	900099525	486
621	900099517	486
622	900099519	486
623	900099523	486
646	900099521	486
704	900024564	294
705	900005923	294
706	900000706	294
727	970082046	258
727	970082046	294
746	970400364	351
749	970216516	297
750	970400365	351
756	900000756	295

GREENLEE

SUPPLIER P/N	ALTEC P/N	PAGE
757	970012948	296
758	900000758	296
759	970039918	294
760	970180889	294
761	970039919	295
765	900000427	297
773	900000773	295
774	900000774	295
776	900000394	296
796	900000426	483
1058	970400343	316
1058	970400343	351
1059	970400342	316
1059	970400342	351
1900	970302574	287
1901	970098602	287
1916	970098597	287
1917	970098598	287
1918	970098600	287
1923	970098595	287
1927	970082044	258
1927	970082044	287
1935	900001935	287
1955	970082043	258
2178	900002178	314
2746	970637275	289
2747	970637276	289
2748	970637277	289
2749	970637279	289
2750	970637278	289
03046	900030460	316
3048	900099493	314
4435	970637198	485
4436	970637199	485
4437	970637200	485
5850	970400344	316
5850	970400344	351
5850	970400344	351
06714	970013228	313
6900	970444494	482
6901	970444496	482
6906	970444479	482
07033	900007033	313
7035	900007035	313
07036	900007036	313
07037	970004962	313
07038	970080072	313
07039	970080074	313
07062	970021641	313
07063	970070123	316
07274	970080075	313
07564	900099654	540
07567	900099652	540
07593	970559546	540
07653	900099646	540
07733	900001350	540
07735	970039878	540
07748	970039885	541
07749	970039888	541
07796	970039890	541
07799	970039884	540
08740	900099644	542
08741	900099643	542
08742	970216802	542
08743	900099641	543
08744	900050749	543
08745	970216804	543
08746	970216805	543
09025	970110614	542
09027	970039889	542
10070	970102813	309
10640	970158458	117
10641	970158697	117
11097	970187379	350

GREENLEE

SUPPLIER P/N	ALTEC P/N	PAGE
11097	970187379	350
11098	970187380	350
11098	970187380	350
11099	970187381	350
11100	970187382	350
11100	970187382	350
11101	970187383	350
11102	970187384	350
11183	900011183	354
11186	809500274	354
11186	809500274	357
11841	900000431	314
11851	900000429	314
11890	970080040	313
12040	970110615	542
15345	900000141	483
16854	900000162	486
16856	900000163	486
16857	900000164	486
17707	970400345	316
17707	970400345	351
20158	970080068	313
20920	970055572	349
20947	970216801	542
21111	970067360	349
21481	900000064	483
23481	970102811	309
23492	970400372	312
23893	970071893	483
24779	970640812	485
25766	970400346	316
25766	970400346	351
31378	900049618	360,383
31395	900000143	483
34136	900000082	482
34137	900000083	482
34138	900000084	482
34317	900099527	485
34317	900099527	486
35213	900000154	483
37868	900037868	350
37869	900037869	350
37870	900037870	350
37871	900037871	350
37959	900000066	485
38568	900038568	358
39143	900000073	486
39144	900000074	486
39245	900000075	486
40647	900040647	360
40652	900040652	360
41107	900030694	361
41108	970019302	361
41189	900041189	357
41795	900041795	361
41796	970014174	361
41877	900041877	360
41941	900041941	360
41960	970012295	359
42096	900042096	360
42190	900042190	357
42192	900042192	357
42237	900042237	354
43136	970091478	308
43177	701069017	358
43178	701069018	358
43180	701069155	358
43973	900043973	358
45206	900045206	295
45207	900045207	295
45240	900045240	297
45378	900045378	314
45379	900000433	314
45382	900000434	314

GREENLEE

GREENLEE

GREENLEE

GREENLEE

SUPPLIER P/N	ALTEC P/N	PAGE
45798	900099795	349
48520	701069149	358
48788	970098617	353
48802	970086937	353
48820	900048820	353
48824	900048824	353
49314	900099489	349
49334	900049334	357
49499	900049499	357
49532	900049533	354
49782	900099796	349
52015	970071888	297
52176	970216519	308
52176	970216519	310
52176	970216519	312
52176	970216519	313
52176	970216519	314
52176	970216519	316
52176	970216519	351
52177	970216794	310
52177	970216794	314
52178	970216795	308
52178	970216795	310
52178	970216795	312
52178	970216795	313
52178	970216795	314
52178	970216795	316
52178	970216795	351
52179	970216796	308
52179	970239618	312
52179	970239618	316
52179	970239618	351
52180	970216796	310
52180	970216796	312
52180	970216796	313
52180	970216796	314
52180	970216796	316
52180	970216796	351
54169	970357700	360
55141	970051929	359
55185	970214216	359
55191	900055191	359
70152	970155213	259
70152	970155213	259
70153	970155214	259
70153	970155214	259
70154	970155215	259
70154	970155215	259
70155	970155216	259
70155	970155216	259
70156	970155217	259
70156	970155217	259
76807	970118121	314
89251	970115173	261
138573	900030694	361
138574	970019302	361
156339	900041219	357
156340	900041220	357
0151-09D	970115170	261
0151-09M	970080816	258
0151-09M	970080816	261
0153-01C	970080769	259
0153-01C	970080769	260
0153-02C	970080817	259
0153-02C	970080817	260
0153-11C	970082055	258
0153-15C	970082058	258
0153-22C	970082061	258
0153-26C	970082088	258
0153-26C	970082068	258
0153-31C	970082069	258
0153-33C	970082071	258
0153-42C	970080820	259
0153-42C	970080820	260

SUPPLIER P/N	ALTEC P/N	PAGE
0154-08	970080782	261
0154-08C	970080775	261
0154-08D	970115176	261
0154-10	970080783	258
0154-10	970080783	261
0154-10C	970080777	261
0154-10D	970115177	261
0154-12	970080784	261
0154-12C	970080781	261
0154-12D	970115178	261
0155-16A	970080795	259
0155-16A	970080795	260
0155-25	970080794	258
0155-25A	970080794	259
0155-25A	970080794	260
0156-11	970080797	259
0156-11	970080797	260
0158-13	970082087	258
0159-12	970080803	258
0159-13	970098040	258
0251-08AD	970115172	261
0251-08AM	970080729	261
0251-08D	970115171	261
0251-08M	970081634	258
0251-08M	970081634	261
0253-01C	970080818	259
0253-01C	970080818	260
0254-11	970080785	258
0254-11	970080785	259
0254-11	970080785	260
0254-12	970080786	259
0254-12	970080786	260
0258-11	970080799	258
0258-11	970080801	259
0258-13	970080800	259
0258-14	970080801	259
0333-A	970080821	259
0351-08M	970080733	258
0351-08M	970080733	261
0358-11L	970081632	258
0451-10D	970115174	261
0451-10M	970080736	258
0451-10M	970080736	261
0451-12D	970115175	261
0451-12M	970080767	261
0451-16D	970080768	261
0453-14C	970082095	258
0652-11	970082091	258
0652-11-CP	970080724	261
156-11	970080797	258
301A	970080730	261
333A	970080821	258
353-01C	970080772	259
353-01C	970080772	259
353-01C	970080772	260
430-500	970637197	485
5123/34514	900099656	541
542-250	900000045	483
5702/07574	900099655	541
5715/34529	900099658	541
5779/07576	900099657	541
5882/07573	970039886	541
608-5	900099510	486
609-5	900099511	486
610-5	900099512	486
611-3	900099513	486
612-2	900099514	486
66TF-11/16	970299183	350
66TF-13/16	970299185	350
66TF-15/16	970299187	350
66TF-9/16	970299181	350
690-15	970637189	485
690-RM	970637190	485
690-RT	970637191	485

SUPPLIER P/N	ALTEC P/N	PAGE
718F	900010507	294
728M	970136930	294
9753-11C	970080773	261
9753-12C	970080731	258
9753-12C	970080731	259
9753-12C	970080731	260
9858-11	970082092	258
9952-11	970080728	261
9953-11	970080774	261
9953-13	970080771	259
9953-13	970080771	260
A-1	970637263	288
AF-1	970637260	288
B-1	970637259	288
BAT18VLI	970216519	320
BF-1	970637262	288
BL-200	970039890	541
CASEWDIES	900004946	320
CJB	900084513	309
CJD3	970015444	309
CJD3	970015444	310
CJD3BG	970080111	309
CJD3O	970080112	309
CJK	970015445	309
CJK	970015445	310
CJXPJ	970089227	309
CLM-1000	970589131	541
CLM-1000E	970595629	541
CM-1350	900001350	540
CM-1550	970039884	540
CM-600	970559546	540
CM-950	900700950	540
CMFGRT-100	900099646	540
CMI-100	900099654	540
CMI-200	900099652	540
CMT-80	970039878	540
CP1	900011001	129
CS-8000	970216803	543
DK6040	970212113	353
DM-200A	900099644	542
DM-210A	900099643	542
DM-300	970138295	541
DM-510A	970216802	542
DM-60	970110615	542
DM-810A	900099641	543
DM-820A	900050749	543
DM-830A	970216804	543
DMHS-1	970217111	543
DML-430A	970216805	543
DMSC-2U	970217109	542
DMSC-9U	970217110	543
E-1	970637239	288
E12CCXL11	970221784	313
E12CCXL12	970221785	313
E-2	970637242	288
E-3	970637248	288
E-4	970637251	288
E-5	970637255	288
E-6	970637265	288
E-7	970637268	288
E-8	970637271	288
E-9	970637274	288
EAC1812	970288397	316
EAC18120	970288397	351
EAC18230	970400352	316
EAC18230	970400352	316
EAC18230	970400352	351
ECCXL11	970221781	315
ECCXL12	970221783	315
EF-1	970637236	288
EF-2	970637240	288
EF-3	970637245	288
EF-4	970637246	288
EF-5	970637258	288
EHP700LU11	970390793	351

SUPPLIER P/N	ALTEC P/N	PAGE
EHP700LU12	970390794	351
EHP700LU120	970400340	351
EHP700LU22	970400339	351
EHP700LU230	970400341	351
EK06ATL11	900081829	311
EK06ATL12	900081830	311
EK06FTL11	900088834	311
EK06FTL12	900088835	311
EK1230L11	900081833	310
EK1230L12	900081834	310
EK1240KL11	970218585	310
EK1240KL12	900081838	310
EK1240L11	970218582	310
EK1240L12	970218584	310
EK12IDL11	970110712	311
EK12IDL12	970110715	311
EK1550FTLU11	970400366	312
EK1550FTLU12	970400367	312
EK1550FTLU20	970400369	312
EK1550FTLU22	970400368	312
EK1550FTLU230	970400370	312
EK1550L11	970216797	311
EK1550L12	970216798	311
EK425L	970289711	308
EK425LB	970218542	308
EK425LD11	970216517	308
EK425LD12	970216518	308
EK425LDBG11	970218576	308
EK425LDBG12	970218577	308
EK425LDO11	970218574	308
EK425LDO12	970218575	308
EK425LK11	970218578	308
EK425LK12	970218581	308
EK622L11	900088833	310
EK622L12	900003552	310
EK628L11	970072158	310
EK628L12	970221685	310
EL122/32	970400353	316
EL122/32	970400353	351
ES25	900022131	314
ES32LU11	970354901	314
ES32LU12	970354904	314
ES750-11	970021736	314
ES750-22	970037486	314
ESC10511	970216799	315
ESC10512	970216800	315
ESC85L11	970071691	316
ESC85L12	970071698	316
ESG105LU11	970476279	316
ESG105LU12	970476287	316
ESG105LU120	970476299	316
ESG105LUB	970476301	316
ESG45L11	970012920	315
ESG45L12	970246250	315
ETS12L11	970155209	315
ETS12L12	970155210	315
F020721	900041795	361
F020723	970014174	361
F024772	970017027	357
F024775	900042105	357
F-1	970637237	288
F13	900049618	360,383
F-2	970637243	288
F-3	970637249	288
F-4	970637253	288
F-5	970637256	288
F-6	970637267	288
F-7	970637270	288
F-8	970637272	288
F-9	970637273	288
G3	970640813	484
GATOR-PK		351
GG1000L	970366432	487

PRODUCT INDEX
BY SUPPLIER ITEM NUMBER

USA: 1-877-GO ALTEC
(1-877-462-5832)

www.alteconnect.com



GREENLEE

SUPPLIER P/N	ALTEC PN	PAGE
GG1000M	970366431	487
GG1000S	970366430	487
GG1-1/0L	970366407	487
GG1-1/0M	970366406	487
GG1-1/0S	970366405	487
GG2/0-4/0L	970366412	487
GG2/0-4/0M	970366411	487
GG2/0-4/0S	970366410	487
GG250-350L	970366417	487
GG250-350M	970366416	487
GG250-350S	970366415	487
GG400-500L	970366422	487
GG400-500M	970366421	487
GG400-500S	970366420	487
GG600-750L	970366427	487
GG600-750M	970366426	487
GG600-750S	970366425	487
GT-11	970082054	258
GT-12	970216801	542
GT-220	970039885	541
GT-540	970039888	541
GT-65	970110614	542
GT-95	970039889	542
GTS-1930	970637230	288
GTS-RDS	970637235	288
GTS-RH	970637234	288
GTS-THHN	970637231	288
GTS-THXH	970637233	288
GTS-XHHW	970637232	288
H4635	900049334	357
H4635	900049334	357
H4660B	900042190	357
H4660B	900042190	357
H4665A	970098349	357
H4670	900042192	357
H4670	900042192	357
H4802	893000400	354
H4802-1	893020500	354
H4802-3	701069084	354
H4802-5	900042200	354
H4802-6	36030021	354
H4905A	900042237	354
H4910A	701069005	355
H6400C	900042260	349
H8508-1	701069023	349
H8508-3	36020021	349
H8508-3V	809500416	349
H8508-IV	812620300	349
HB10	900049830	361
HCS816	900049566	359
HCS820	900049603	359
HFC30	970102585	361
HID6506	970042309	348
HK1230	970039916	298
HK1240	970039915	298
HK520	970012892	296
HKL1232	900000176	298
Holder	716201070	361
HPB25	900049537	356
HPB35	900049538	356
HPB45-1AVS	900002197	356
HPB45-2AVS	900002198	356
HPB55-1AVS	900002201	356
HPD-HV-U	809500274	354
HPD-HV-U	809500274	357
HPD-T-U	900011183	354
HRD-1	900011193	355
HRD44A	900000944	355
HRD-58	900011192	355
HTA4GL	970400354	316
HTA4GL	970400354	351
HW1	970329578	348
HW1V	970329580	348

GREENLEE

SUPPLIER P/N	ALTEC PN	PAGE
HW3	970491894	348
HW3	970491894	348
JRF-4EPR	970637275	289
JRF-4XLP	970637276	289
JRF-REPR	970637277	289
JRF-PPK	970637279	289
JRF-RXLP	970637278	289
K425BG	900002065	298
K425K58	900008160	298
K425KO	900008161	298
K425O	900002064	298
KA12-1/0	900035792	342
KA12-2	970364791	342
KA12-2/0	900035793	342
KA12-250	970103581	342
KA12-3/0	900035794	342
KA12-300	900035787	342
KA12-350	900035788	342
KA12-4	970364780	342
KA12-4/0	900035785	342
KA12-400	900035789	342
KA12-500	900035795	342
KA12-6	970103574	342
KA12-600	900035790	342
KA12-750	900035796	342
KA12-8	970103570	342
KC12-1	970103590	342
KC12-1/0	970103635	342
KC12-2	970364786	342
KC12-2/0	970103841	342
KC12-250	970364809	342
KC12-3/0	970103846	342
KC12-300	970103847	342
KC12-350	970364814	342
KC12-4	970103588	342
KC12-4/0	970364795	342
KC12-400	970103848	342
KC12-500	970103849	342
KC12-6	970103585	342
KC12-600	970103851	342
KC12-750	970364817	342
KD12-10	970098712	344
KD12-11	970098786	344
KD12-12	970070859	344
KD12-14	970098788	344
KD12-15	970098789	344
KD12-17	970365399	344
KD12-18	970098803	344
KD12-19	970095674	344
KD12-20	970098804	344
KD12-21	970073265	344
KD12-30	970098806	344
KD12-30	970098806	344
KD12-32	970098808	344
KD12-35	970098810	344
KD12-36	970005624	344
KD12-37	970005627	344
KD6-10	970026993	343
KD6-11	68300116	343
KD6-12	900010167	343
KD6-14	900001614	343
KD6-15	900010170	343
KD6-16	900001616	343
KD6-17	970063079	343
KD6-18	900010173	343
KD6-19	900010174	343
KD6-20	900010175	343
KD6-21	900010176	343
KD6-22	900010177	343
KD6-24	900010179	343
KD6-25	900010180	343
KD6-27	970015446	308
KD6-27	970015446	343

GREENLEE

SUPPLIER P/N	ALTEC PN	PAGE
KWADP	970389709	320
L088009	900042853	358
L107	970082052	258
LHFS-210003	900042909	358
LP6-01	970400379	352
LP6-02	970400380	352
LP6-03	970400381	352
LP6-04	970400382	352
LP6-05	970400383	352
LP6-06	970400384	352
LP6-07	970400385	352
LP6-08	970400386	352
LP6-09	970400387	352
LP6-10	970400388	352
LP6-11	970400389	352
LP6-12	970400390	352
LP6-13	970400391	352
LP6-14	970400392	352
LP6-15	970400393	352
LP6-16	970400394	352
LP6-17	970400395	352
LP6-18	970400396	352
LP6-19	970400397	352
LP6-20	970400398	352
LPK1230	900042184	353
LPK1240	900049345	353
LPK1240K	900048735	353
LPK1550	900048750	353
LPK1550FT	970400377	312
MVB	970444491	482
NC-10-38MF	970567874	351
NC-30-38MF	970649408	351
NC-6-38MF	970649378	351
PAT500SJ66-LI	970637171	320
PAT500SJ66-LIKIT1	970637174	320
PAT500SJ68-LI	970637172	320
PAT500SJ68-LIKIT1	970637175	320
PAT500SJ6-LI	970637170	320
PAT500SJ6-LIKIT1	970637173	320
PATCHGR1	970216795	320
PATCHGR1DC	970216796	320
PATJAWSMD6	970235367	320
PATJAWSMD66	970390494	320
PATJAWSMD68	970203838	320
PATJAWSMD6K	970389708	320
PATMD66-LI	970358637	320
PATMD66-LIKIT1	970492887	320
PATMD66-LIWCJ	970492890	320
PATMD68-LI	970336938	320
PATMD68-LIKIT1	970492888	320
PATMD68-LIWCJ	970492891	320
PATMD6K-LI	970389705	320
PATMD6-LI	970321846	320
PATMD6-LIKIT1	970492886	320
PATMD6-LIWCJ	970492889	320
PT29291	900029291	320
PT-K01	900045085	259
PT-K01	900045085	259
PVA0021	900099682	361
PVA0022	900022396	361
PVA1122	2100072	361
R-1	970637238	288
R-10	970637264	288
R-11	970637266	288
R-12	970637269	288
R-2	970637241	288
R-3	970637244	288
R-4	970637247	288
R-5	970637250	288
R-6	970637252	288
R-7	970637254	288
R-8	970637257	288
R-9	970637261	288

GREENLEE

SUPPLIER P/N	ALTEC PN	PAGE
RA96	900049533	354
RH10	970637192	485
RH15	970637193	485
RH25	970637194	485
RK06AT	970400356	351
RK06FT	970400357	351
RK1240	970190442	351
RK1240C	970400359	351
RK12CX	970649374	351
RK12ID	970649376	351
RK1550	900005386	351
RK1550FT	970400361	312
RK1550FT	970400361	351
RK425	970649371	351
RK6040	900010604	351
RK6040	900010604	353
S2613	900099526	485
S2613	900099526	486
SA54	900049534	354
SDK105	970400363	351
TC-10	900707534	541
TC3	970400355	316
TOOLBAGMDLI	970389707	320
UA	900049532	354
UA12P	970080040	313
UA12T	970080068	313
UA15T	970400371	312
UA22	970021641	313
UAK	900007033	315
UAK	900007033	315
UAW	900007035	315
UAW	900007035	313
UC26	970013228	313
UC40	900007036	315
UC40	900007036	313
UCACSR	970004962	315
UCACSR	970004962	313
UCUNC12	970080075	313
UCUNC14	970080072	313
UCUNC38	970080074	313
UDIEKITAL	970216399	320
UDIEKITCU	970216400	320
UDIEKITHYGRD	970216401	320
W28K	970015446	320
WDIEKITAL	970637134	320
WDIEKITCU	970637133	320
WDIETREE	900096183	320

HANNAY

SUPPLIER P/N	ALTEC PN	PAGE
GC10-17-19	970322718	156
GCR10-17-19	705201178	156
SGCR10-17-19	970133048	156

**HARRINGTON
HOISTS**

SUPPLIER P/N	ALTEC PN	PAGE
LB008	970089414	225
LB015	900011215	225
LB030	970091548	225
LB060	970089415	225
LX003	970103275	225

HASTINGS

SUPPLIER P/N	ALTEC PN	PAGE
266	970279737	552
266	970279737	553
3114	900003114	444
3115	900003115	444
3116	900003116	444
3118	900003118	444
3119	900003119	444

HASTINGS

SUPPLIER P/N	ALTEC P/N	PAGE
3120	900003120	444
3172	970259653	404
3413	970080067	442
3414	970016176	442
3479	813000873	447
3480	900703480	442
3481	970080058	442
3482	970080062	442
3483	970080064	442
3489	813000807	447
3649	716030546	24
4370	900004370	409
4601	900004601	444
4602	900004602	444
4603	970088936	444
4604	900704604	444
4605	970098979	444
5034	900011583	448
5034	900011583	448
5558	900005558	445
6020	970098618	471
6023	970098528	471
6026	970098529	471
6040	970098621	471
6050	900006050	471
6055	970138297	471
6060	970018234	471
6065	970094042	471
6509	970052746	448
6702	900706702	552
6722	970279738	552
6722	970279738	553
6754	970100353	408
6756	970640879	407
6757	970640880	407
6758	970640881	407
6759	970640882	407
6760	970640883	407
6761	705201292	407
6762	705201181	407
6763	970361775	407
6767	900006767	408
6793	970098209	552
6795	814000372	24, 162
6795	814000372	446
6796	900099601	24, 162
6796	900099601	446
6800	716030542	24
6850	970106915	24, 162
6850	970106915	446
6929	716030543	24, 162
6929	716030543	446
7701	970255738	552
8104	900008104	442
8106	900008106	442
8108	900030293-	442
8110	900008110	442
8112	900008112	442
8158	900008158	442
9071	970640869	405
9123	002030109	405
9153	970232872	405
10016	900010016	449
10375	900001037	404
10376	900001037	404
10476	900010476	404
10477	970156153	404
10478	970302556	404
11000	970243937	409
11051	970208092	233
11052	970208091	233
11190	970215490	404
11192	970152331	404

HASTINGS

SUPPLIER P/N	ALTEC P/N	PAGE
11361	970206491	233
11362	970208088	233
11367	970129486	233
11368	970160072	233
11387	716030535	448
11387	716030535	448
11656	970640875	407
11657	970546065	407
11658	970046061	407
11660	970640876	407
11683	72030092	447
11973	72030057	448
11974	72030034	448
11974	72030034	448
12006	701702085	448
12006	701702085	448
12282	900012282	405
12423	811001674	408
12594	900712594	443
12666	72030100	448
12936	970016339	471
12998	705201161	407
12999	705201162	407
13000	970026881	407
13001	970092396	407
13004	970640884	409
13102	900050259	409
13128	701702080	448
13412	900013412	442
13413	900013413	442
13414	900013414	442
13415	900013415	442
13495	900011584	448
13765	900013765	409
13768	970079323	409
20923	900020923	445
20925	900020925	445
20926	900020926	445
20927	900020927	445
21056	970640867	405
21057	970068860	405
21070	705201182	404
21307	811001042	404
21552	069296175	404
21571	970180483	405
21575	900002157	404
21608	900021608	405
21642	72030087	447
21644	72030036	448
21703	705201335	406
21705	970640870	406
21706	970640871	406
21720	970126170	406
21721	878070912	406
21722	970640873	406
21725	970640874	406
21726	970640872	406
81814	900081814	442
01-3200	69298147	162
01-3300	705301209	162
01-3400	69298074	162
01-3500	970066583	162
Jan-00	69298276	162
01-4002	970162323	305
(8104-U)	970111607	442
(8106-U)	970095768	442
(8108-U)	970073529	442
(8110-U)	970111612	442
(8112-U)	970111614	442
01-071	970098530	471
01-3200-P	970073541	162
01-3300-P	970073542	162
01-33350	900013350	445

HASTINGS

SUPPLIER P/N	ALTEC P/N	PAGE
01-33351	900013351	445
01-33352	900013352	445
01-33353	900013353	445
01-33354	900013354	445
01-33355	900013355	445
01-33356	900013356	445
01-33357	900013357	445
01-3400-P	69298074	162
01-3500-P	970197806	162
01-3600-P	970197807	162
01-604	970098533	471
05-829	70420648	122
05-831	70420301	128
05-832	813000204	128
05-840	970333356	447
05-841	970333359	447
05-951	705400094	122
05-960	70420091	122
05-961	70420302	122
06-178	970155186	249
06-179	970155188	249
06-180	970092015	249
10-019	900001910	449
10-088	970516123	446
100-90	900010090	446
10-091	716030528	446
10-091	900710091	446
10-094	970160288	449
10-169	900010169	446
10-171	900010171	446
10-178	970023390	449
10-183	970100359	449
10-188	900010188	446
10-207	970162322	305
10-260	970057161	305
10-312	970071135	257
10-667	970054983	305
11-006	900711006	443
11-014	970018238	305
21546-1	900021546	405
4367-1	970640868	405
4367-2	970267092	405
460-10	900046010	445
460-12	900046012	445
460-4	900004604	445
460-6	900004606	445
460-8	900004608	445
4678-10	900046781	444
4678-12	900046782	444
4678-14	900046784	444
4678-6	900046786	444
4678-8	900046788	444
4680-10	900046801	444
4680-12	900046802	444
4680-14	900046804	444
4680-8	900046808	444
4706-4	10011638	404
501-10	900050110	445
501-12	900050112	445
501-4	900050140	445
501-6	900050160	445
501-8	900050180	445
541-10	900054110	445
541-12	900054112	445
541-14	900054114	445
541-16	900054116	445
541-18	900054118	445
541-20	900054120	445
541-6	900054160	445
541-8	900054180	445
5460-4	900005460	444
5460-6	900000546	444
5460-8	900008546	444

HASTINGS

SUPPLIER P/N	ALTEC P/N	PAGE
5462-2	900005462	444
5462-4	900005462	444
5462-6	900005462	444
5462-8	900005462	444
546-4	900005464	444
546-6	900005466	444
546-8	900005468	444
5514-6	900005416	444
5541-10	900005410	444
5541-8	900005418	444
5546-10	900005461	444
5546-4	900005464	444
5546-6	900005466	444
5546-8	900005468	444
55547-10	900005471	444
55547-4	900005474	444
55547-6	900005476	444
55547-8	900005478	444
567-6	900005676	445
567-8	900005678	445
5755-6	900005399	408
6020-1	970098619	471
6040-1	970098622	471
6496-1	900099602	24
6496-1	900099602	162
6496-1	900099602	446
6702-1	900767021	552
6702-2	970175507	552
6702-3	970131308	552
6709-1	970067625	552
6724-1	900070661	408
6795-1	814000373	24
6795-1	814000373	162
6795-1	814000373	446
6798-1	814000371	24
6798-1	814000371	162
6798-1	814000371	446
8158-U	900081580	442
81814-U	900001814	442
9123CC	970046060	405
9153CC	970479249	405
A10017	900010017	449
A10018	900010018	449
A10019	900010019	449
A10020	900710020	449
A10021	900710021	449
A10022	900010022	449
A10025	900010025	445
A11000	900011000	449
A18007	900018007	445
A18008	900018008	445
A30008	970105108	449
A30321	970098531	471
A30322	970098532	471
C-35	900003500	442
EV-30	970181902	443
EV-35	970192119	443
EV-40	970186722	443
EX3-726	970428741	448
EX3-729	970118724	24
EX-3729	970118724	447
EX3-818	970291325	24, 163
EX3-818	970291325	446
HV-208	900002080	443
HV-212	900020120	443
HV-216	900020160	443
HV-230	970072872	443
HV-235	900000235	443
HV-240	900002424	443
P10036	900010036	445
P10038	900010038	445
P10431	900010044	449
P30244	970640877	407

PRODUCT INDEX
BY SUPPLIER ITEM NUMBER

USA: 1-877-GO ALTEC
(1-877-462-5832)

www.alteccconnect.com

HASTINGS

SUPPLIER P/N	ALTEC PN	PAGE
P30245	811000966	407
P30246	811001559	407
P30247	2000198	407
P30916	970527206	407
P30917	970640878	407
P31444	970516128	446
P50349	878070982	407
S-212	900002120	443
S-216	900002160	443
S-220	970052744	443
S-225	900002250	443
S-230	900002300	443
S-235	900002350	443
SH-200	900022200	443
SH-216	900002166	443
SH-230	900000230	443
SH-250	900002500	443
ST-220	900060220	443
ST-230	900002301	443
ST-235	970005496	443
ST-240	90000551	443

HD ELECTRIC

SUPPLIER P/N	ALTEC PN	PAGE
050-00300-PRX	970444088	547
3ID-100:	970588615	548
61-763	970291124	554
B-2	970444089	547
B-30	970444074	546
B-5:	970588615	548
B-5:	970588613	548
C-10FRVW	970588604	547
C-10FRVWP	970588605	547
C-10VW	970308028	547
C-10VWP	970588606	547
CS-DVI-5	970444073	546
CS-HVA	970588614	548
DVI-100	970444065	546
DVI-100/K01	970297815	546
DVI-100/K02	970108005	546
DVI-100T/K01	970444066	546
DVI-100T/K02	970444067	546
DVI-500	970444068	546
DVI-500/K01	970444499	546
DVI-500/K02	970321033	546
DVI-500T/K01	970444069	546
DVI-500T/K02	970444070	546
DVM-80UVK	970413671	546
DVM-80UVM	970405501	546
HP-DVI-2	970444071	546
HP-DVI-6	970444072	546
HSA-2500	970444075	546
HVA-2000:	970588612	548
IEP-DVI-5	970342350	546
IEP-UD/C	970113463	553
LV-5	970588609	548
LV-5/K01	970588608	548
LV-EH	970588611	548
LV-GS	970588610	548
PRX-500	970280266	547
PRX-500:	970280266	554
PRX-500/K01	970444081	547
PRX-500/K02	970401503	547
PRX-500/K03	970444082	547
PRX-500B	970444083	547
PRX-500H	970321812	547
PRX-500H	970321812	554
PRX-69D	970280266	547
PRX-69D/K01	970444076	547
PRX-69D/K02	970444077	547
PRX-69D/K03	970444078	547
PRX-69DB	970444080	547
PRX-69DH	970444079	547

HD ELECTRIC

SUPPLIER P/N	ALTEC PN	PAGE
PRX-CORD	970444084	547
PRX-CS	970444087	547
PRX-HS	970444086	547
PRX-XF	970444085	547
PT-DVI	970342354	546
S-4H	970252237	546
S-6H	970444500	546
TAG-200	970113459	553
TAG-200/KIT	970100978	553
TAG-200MR	970113460	553
TAG-200MR/KIT	970113461	553
TAG-330	900000348	554
VW-20H	970493285	547
VW-20HFR	970491901	547
VW-20HFR-K	970588598	547
VW-20H-K	970588601	547
VW-K-BAG	970588607	547
VWP-20H	970588602	547
VWP-20HFR	970588599	547
VWP-20HFR-K	970588600	547
VWP-20H-K	970588603	547

HISCO

SUPPLIER P/N	ALTEC PN	PAGE
HI48CHS	900099377	572
HI48CHS-10	900099383	572
HI48CHS-12	900099385	572
HI48CHS-8	900099387	572
HI72CHS	900099378	572
HI72CHS-10	900099384	572
HI72CHS-12	900099386	572
HI72CHS-8	900099388	572

HK PORTER / APEX

SUPPLIER P/N	ALTEC PN	PAGE
0090FC	900700090	305
0090FC	900700090	305
0090MC	970081291	305
0090MC	970081291	305
0190FC	900011990	305
0190FC	900011990	305
0190FCX	970236738	305
0190FCX	970236738	305
0190MC	900088894	305
0190MC	900088894	305
0290FC	970066906	305
0290FC	970066906	305
0290FCX	970236908	305
0290FCX	970236908	305
0290MC	900070024	305
0290MC	900070024	305
0290MC	900070024	305
0290PHFCS	970637574	304
0390FC	970257872	305
0390FC	970257872	305
0390FCX	970091061	305
0390FCX	970091061	305
0390MC	970099032	305
0390MC	970099032	305
0390MC	970099032	305
0590MC	970637575	305
0590MC	970637575	305
0590MCX	970131789	305
0590MCX	970131789	305
0890MA	970637572	304
0890SMC	970637571	304
1490MC	970136397	305
1490MC	970136397	305
1490PHFCS	970637573	304
8690CK	900008690	304
8690FH	900708690	304
8690TN	900786900	304

HOFFMAN BOOTS

SUPPLIER P/N	ALTEC PN	PAGE
10DL-10.5D	900070571	86
10DL-10.5E	900070308	86
10DL-10.5EEE	970400109	86
10DL-10D	900070592	86
10DL-10E	970207169	86
10DL-10EEE	970400108	86
10DL-11.5D	900070310	86
10DL-11.5E	900070309	86
10DL-11.5EEE	970400111	86
10DL-11D	900070657	86
10DL-11E	970400069	86
10DL-11EEE	970400110	86
10DL-12D	900070343	86
10DL-12E	970318050	86
10DL-12EEE	970400112	86
10DL-13D	900070658	86
10DL-13E	970205742	86
10DL-13EEE	970400113	86
10DL-14D	970205741	86
10DL-15D	970281083	86
10DL-7.5D	970261111	86
10DL-7.5E	970400066	86
10DL-7D	900070660	86
10DL-7E	970400065	86
10DL-8.5D	900070311	86
10DL-8.5E	900070659	86
10DL-8.5EEE	970400105	86
10DL-8D	970258504	86
10DL-8E	970400067	86
10DL-8EEE	970400104	86
10DL-9.5D	900070312	86
10DL-9.5E	970176191	86
10DL-9.5EEE	970400107	86
10DL-9D	900070344	86
10DL-9E	970400068	86
10DL-9EEE	970400106	86
10STD L-10.5D	970400089	86
10STD L-10.5E	970400090	86
10STD L-10.5EEE	970400091	86
10STD L-10D	970400086	86
10STD L-10E	970400087	86
10STD L-10EEE	970400088	86
10STD L-11.5D	970400095	86
10STD L-11.5E	970400096	86
10STD L-11.5EEE	970400097	86
10STD L-11D	970400092	86
10STD L-11E	970400093	86
10STD L-11EEE	970400094	86
10STD L-12D	970400098	86
10STD L-12E	970400099	86
10STD L-12EEE	970400100	86
10STD L-13D	970400101	86
10STD L-13E	970400102	86
10STD L-13EEE	970400103	86
10STD L-7.5D	970400072	86
10STD L-7.5E	970400073	86
10STD L-7D	970400070	86
10STD L-7E	970400071	86
10STD L-8.5D	970400077	86
10STD L-8.5E	970400078	86
10STD L-8.5EEE	970400079	86
10STD L-8D	970400074	86
10STD L-8E	970400075	86
10STD L-8EEE	970400076	86
10STD L-9.5D	970400083	86
10STD L-9.5E	970400084	86
10STD L-9.5EEE	970400085	86
10STD L-9D	970400080	86
10STD L-9E	970400081	86
10STD L-9EEE	970400082	86
600LEATHERPOW-10.5D	970400248	88
600LEATHERPOW-10.5EE	970400261	88
600LEATHERPOW-10D	970400247	88

HOFFMAN BOOTS

SUPPLIER P/N	ALTEC PN	PAGE
600LEATHERPOW-10EE	970400260	88
600LEATHERPOW-11.5D	970400250	88
600LEATHERPOW-11.5EE	970400263	88
600LEATHERPOW-11D	970400249	88
600LEATHERPOW-11E	970400262	88
600LEATHERPOW-12D	970400251	88
600LEATHERPOW-12EE	970400264	88
600LEATHERPOW-13D	970400252	88
600LEATHERPOW-13EE	970400265	88
600LEATHERPOW-14D	970400253	88
600LEATHERPOW-7.5D	970400242	88
600LEATHERPOW-7D	970400241	88
600LEATHERPOW-8.5D	970400244	88
600LEATHERPOW-8.5EE	970400257	88
600LEATHERPOW-8D	970400243	88
600LEATHERPOW-8EE	970400256	88
600LEATHERPOW-9.5D	970400246	88
600LEATHERPOW-9.5EE	970400259	88
600LEATHERPOW-9D	970400245	88
600LEATHERPOW-9EE	970400258	88
600STLEATHERPOW-10.5D	970400223	88
600STLEATHERPOW-10.5EE	970400236	88
600STLEATHERPOW-10D	970400222	88
600STLEATHERPOW-10EE	970400235	88
600STLEATHERPOW-11.5D	970400225	88
600STLEATHERPOW-11.5EE	970400238	88
600STLEATHERPOW-11D	970400224	88
600STLEATHERPOW-11EE	970400237	88
600STLEATHERPOW-12D	970400226	88
600STLEATHERPOW-12EE	970400239	88
600STLEATHERPOW-13D	970400227	88
600STLEATHERPOW-13EE	970400240	88
600STLEATHERPOW-14D	970400228	88
600STLEATHERPOW-7.5D	970400217	88
600STLEATHERPOW-7D	970400216	88
600STLEATHERPOW-8.5D	970400219	88
600STLEATHERPOW-8.5EE	970400232	88
600STLEATHERPOW-8D	970400218	88
600STLEATHERPOW-8EE	970400231	88
600STLEATHERPOW-9.5D	970400221	88
600STLEATHERPOW-9.5EE	970400234	88
600STLEATHERPOW-9D	970400220	88
600STLEATHERPOW-9EE	970400233	88
EH1410-10	970400168	91
EH1410-11	970400169	91
EH1410-12	970400170	91
EH1410-13	970400171	91
EH1410-14	970400172	91
EH1410-7	970400165	91
EH1410-8	970400166	91
EH1410-9	970400167	91
EH1412-10	970400176	91
EH1412-11	970400177	91
EH1412-12	970400178	91
EH1412-13	970400179	91
EH1412-14	970400180	91
EH1412-7	970400173	91
EH1412-8	970400174	91
EH1412-9	970400175	91
EH1414-10	970400184	91
EH1414-11	970400185	91
EH1414-12	970400186	91
EH1414-13	970400187	91
EH1414-14	970400188	91
EH1414-7	970400181	91
EH1414-8	970400182	91
EH1414-9	970400183	91
L1210-10	970400193	89
L1210-11	970400194	89
L1210-12	970400195	89
L1210-13	970400196	89
L1210-14	970400197	89
L1210-6	970400189	89

HOFFMAN BOOTS**HOFFMAN BOOTS****HOOK INTERNATIONAL****HUBBELL POWER SYSTEMS**

SUPPLIER P/N	ALTEC PN	PAGE
L1210-7	970400190	89
L1210-8	970400191	89
L1210-9	970400192	89
L1212-10	970400202	89
L1212-11	970400203	89
L1212-12	970400204	89
L1212-13	970400205	89
L1212-14	970400206	89
L1212-6	970400198	89
L1212-7	970400199	89
L1212-8	970400200	89
L1212-9	970400201	89
L1214-10	970400211	89
L1214-11	970400212	89
L1214-12	970400213	89
L1214-13	970400214	89
L1214-14	970400215	89
L1214-6	970400207	89
L1214-7	970400208	89
L1214-8	970400209	89
L1214-9	970400210	89
L1310-10	970400118	90
L1310-11	970400119	90
L1310-12	970400120	90
L1310-13	970400121	90
L1310-14	970400122	90
L1310-15	970400123	90
L1310-6	970400114	90
L1310-7	970400115	90
L1310-8	970400116	90
L1310-9	970400117	90
L1312-10	970349826	90
L1312-11	970400128	90
L1312-12	970400129	90
L1312-13	970400130	90
L1312-14	970400131	90
L1312-15	970400132	90
L1312-6	970400124	90
L1312-7	970400125	90
L1312-8	970400126	90
L1312-9	970400127	90
L1314-10	970222691	90
L1314-11	970400135	90
L1314-12	970400136	90
L1314-13	970400137	90
L1314-14	970400138	90
L1314-15	970400139	90
L1314-6	970400133	90
L1314-7	970400134	90
L1314-8	970341605	90
L1314-9	970272814	90
L1410-10	970400142	90
L1410-11	970395851	90
L1410-12	970400143	90
L1410-13	970400144	90
L1410-14	970400145	90
L1410-15	970400146	90
L1410-7	970400140	90
L1410-8	970400141	90
L1410-9	970339650	90
L1412-10	970400150	90
L1412-11	970400151	90
L1412-12	970400152	90
L1412-13	970400153	90
L1412-14	970400154	90
L1412-15	970400155	90
L1412-7	970400147	90
L1412-8	970400148	90
L1412-9	970400149	90
L1414-10	970400159	90
L1414-11	970400160	90
L1414-12	970400161	90
L1414-13	970400162	90

SUPPLIER P/N	ALTEC PN	PAGE
L1414-14	970400163	90
L1414-15	970400164	90
L1414-7	970400156	90
L1414-8	970400157	90
L1414-9	970400158	90
LPOWER-10.5D	970400296	87
LPOWER-10.5EE	970400308	87
LPOWER-10D	970400295	87
LPOWER-10EE	970400307	87
LPOWER-11.5D	970400298	87
LPOWER-11.5EE	970400310	87
LPOWER-11D	970400297	87
LPOWER-11EE	970400309	87
LPOWER-12EE	970400311	87
LPOWER-13D	970400299	87
LPOWER-13EE	970400312	87
LPOWER-14D	970400300	87
LPOWER-7.5D	970400291	87
LPOWER-7D	970400290	87
LPOWER-8.5D	970400293	87
LPOWER-8.5EE	970400304	87
LPOWER-8D	970400292	87
LPOWER-8EE	970400303	87
LPOWER-9.5D	970400294	87
LPOWER-9.5EE	970400306	87
LPOWER-9EE	970400305	87
LST1210-10	970400269	89
LST1210-11	970400270	89
LST1210-12	970400271	89
LST1210-13	970400272	89
LST1210-14	970400273	89
LST1210-7	970400266	89
LST1210-8	970400267	89
LST1210-9	970400268	89
LST1212-10	970400277	89
LST1212-11	970400278	89
LST1212-12	970400279	89
LST1212-13	970400280	89
LST1212-14	970400281	89
LST1212-7	970400274	89
LST1212-8	970400275	89
LST1212-9	970400276	89
LST1214-10	970400285	89
LST1214-11	970400286	89
LST1214-12	970400287	89
LST1214-13	970400288	89
LST1214-14	970400289	89
LST1214-7	970400282	89
LST1214-8	970400283	89
LST1214-9	970400284	89
STPOWER-10.5D	970400320	87
STPOWER-10.5EE	970400332	87
STPOWER-10D	970400319	87
STPOWER-10EE	970400331	87
STPOWER-11.5D	970400321	87
STPOWER-11.5EE	970400334	87
STPOWER-11EE	970400333	87
STPOWER-12D	970400322	87
STPOWER-12EE	970400335	87
STPOWER-13D	970400323	87
STPOWER-13EE	970400336	87
STPOWER-14D	970400324	87
STPOWER-7.5D	970400314	87
STPOWER-7D	970400313	87
STPOWER-8.5D	970400316	87
STPOWER-8.5EE	970400328	87
STPOWER-8D	970400315	87
STPOWER-8EE	970400327	87
STPOWER-9.5D	970400318	87
STPOWER-9.5EE	970400330	87
STPOWER-9D	970400317	87
STPOWER-9EE	970400329	87

SUPPLIER P/N	ALTEC PN	PAGE
E12-10	970588788	231
E12-10-30	970588787	231
E153-10	970158422	231
E2.5-6	970158433	231
E24-12	970158429	231
EH12-10	970588790	231
EH12-10	970588792	231
EH12-10-30	970588789	231
EH153-10	970158426	231
EH24-12	970158430	231
EHG12-10-30	970588791	231
EHG153-10	970588795	231
EHG24-12	970588799	231
EHS12-10	970588794	231
EHS12-10-30	970588793	231
EHS153-10	970158428	231
EHS153-10-30	970588797	231
EHS24-12	970158431	231
EHS153-10-30	970588796	231
FR1000	970207898	230
FR12005	970207916	230
FR12010	970207917	230
FR12015	970207919	230
FR12020	970207920	230
FR1505	970207899	230
FR1510	970207900	230
FR1515	970207901	230
FR1520	970207902	230
FR2005	970207903	230
FR2010	970207904	230
FR2015	970207905	230
FR2020	970207906	230
FR3005	970207907	230
FR3010	970207908	230
FR3015	970207910	230
FR3020	970207911	230
FR500	970179315	230
FR6005	970207912	230
FR6010	970207913	230
FR6015	970207914	230
FR6020	970207915	230
H1-15	970208484	230
H12-15	970208517	230
H15-20	970208539	230
H153-13	970208525	230
H153-20	970208544	230
H153-30	970208546	230
H2.5-6	970208565	230
H24-12HD	970208561	230
H24-20	970208548	230

HUBBELL POWER SYSTEMS

SUPPLIER P/N	ALTEC PN	PAGE
C4060000	900040600	467
C4060029	970040586	467
C4060030	900004030	467
C4060082GA	900740600	466
C4060181	900040601	467
C4060181GA	970040972	467
C4060296	900040629	466
C4060299	900040602	466
C4060306	970016341	466
C4060309	900060309	466
C4060346	900000346	466
C4060348	970040588	466
C4060514GA	970022458	467
C4060530	970040137	466
C4060531	900000531	466
C4060532	970040591	466
C4060537	970071636	466
C4060550	970040577	467

SUPPLIER P/N	ALTEC PN	PAGE
C4060551	970040579	467
C4060557	970022454	467
C4060557L	970040587	467
C4170148	970292526	474
C4170149	970454599	474
C4170150	970454595	474
M4933	970053679	467
M4937-1	970040580	467
M4937-2	970040582	467
M4937-4	970323921	467
M4937-6	970040584	467
P4060184	970055622	467
PSC4060600	970457842	474
PSC40606010	970457843	474
PSC4060648	970602757	467
PSC40606050	970602755	467
PSC4060651	970602756	467
PSCGLB18CCG	970567204	474
PSCGLB30CCS	970567205	474
PSCGLP10GN10	970567175	473
PSCGLP10GN11	970567176	473
PSCGLP10GN12	970567177	473
PSCGLP10GN7	970567172	473
PSCGLP10GN8	970567173	473
PSCGLP10GN9	970567174	473
PSCGLP12CN10	970567186	473
PSCGLP12CN11	970567187	473
PSCGLP12CN12	970567188	473
PSCGLP12CN8	970567184	473
PSCGLP12CN9	970567185	473
PSCGLP13GN10	970567181	473
PSCGLP13GN11	970567182	473
PSCGLP13GN12	970567183	473
PSCGLP13GN7	970567178	473
PSCGLP13GN8	970567179	473
PSCGLP13GN9	970567180	473
PSCGLP14CN10	970567191	473
PSCGLP14CN11	970567192	473
PSCGLP14CN12	970567193	473
PSCGLP14CN8	970567189	473
PSCGLP14CN9	970567190	473
PSCGLP15CN10	970567196	473
PSCGLP15CN11	970567197	473
PSCGLP15CN12	970567198	473
PSCGLP15CN8	970567194	473
PSCGLP15CN9	970567195	473
PSCGLP16CN10	970567201	473
PSCGLP16CN11	970567202	473
PSCGLP16CN12	970567203	473
PSCGLP16CN8	970567199	473
PSCGLP16CN9	970567200	473
PSCS1	970457839	474
4012	900004012	221
66780	900066780	431
630013	900063001	415
630017	900099360	415
630027	900050744	417
630028	900050745	417
3301027	900701027	237
3302044	900702044	237
3302046	900702046	237
3302048	900702048	237
3302050	900702050	237
3302052	900702052	237
3302054	970111987	237
20320050	970354599	237
20320051	970354601	237
20320052	970354602	237
20320053	970354603	237
20320054	970354604	237
33041085	900741085	237
33271037	970111992	237
33271038	970101969	237

PRODUCT INDEX
BY SUPPLIER ITEM NUMBERUSA: 1-877-GO ALTEC
(1-877-462-5832)

www.alteccconnect.com

HUBBELL POWER SYSTEMS

HUBBELL POWER SYSTEMS

HUBBELL POWER SYSTEMS

HUBBELL POWER SYSTEMS

PRODUCT INDEX
BY SUPPLIER ITEM NUMBER

USA: 1-877-GO ALTEC
(1-877-462-5832)

www.alteconnect.com

SUPPLIER P/N	ALTEC PN	PAGE
33271039	970101104	237
33271040	970111995	237
(C4176086)	69296014	403
(C6001754)	900061754	403
(C6002618A)	900062618	403
(G3370)	69296011	403
(S6116)	900006116	403
(T6001798)	900061798	403
2230-1	970053519	254
3011S	900099410	221
630011HD	70000030	415
630012HD	900063002	415
C1021583	70000066	416
C1021595	70000034	416
C1300010	900013010	417
C3020004	900099863	417
C3030020	900030020	417
C3030045	900030045	418
C3030069HD	70000032	415
C3030070	970089872	415
C3030090	70000018	415
C3030115	900030115	417
C3030139	900030139	417
C3030684	705400607	417
C3030936	70000051	416
C3030937	70000052	416
C3030981	70000053	416
C3030982	900030982	416
C3030983	70000054	416
C3030987	900050747	417
C3030988	900050748	417
C3031026	900099720	416
C3031063	705400108	416
C3031064	896021700	416
C3031222	900099684	417
C3031223	900031223	417
C3031226	900031226	417
C3031227	900031227	417
C3031571	970351294	416
C3031578	900031340	418
C3031689	970637127	418
C3031690	970637128	418
C3031723	970637129	418
C3031724	970637130	418
C3080856	900080856	223
C3080890	41511001	223
C3080900	900080900	222
C3080903	41511000	223
C3080925	970026860	222
C3081170	701300035	221
C3081172	41510000	221
C3081180	900081180	222
C3081190	900730811	222
C3081335	900081335	223
C3081370	701300040	221
C3081443	804000337	223
C3090349	900030903	221
C3090438	900090438	221
C3090439	900090439	221
C3090440	900090440	221
C3090441	900090441	221
C3090442	900090442	221
C4000090	900040090	423
C4000268	72090304	412
C4000315	900040315	423
C4000440	900040400	423
C4000445	970053457	439
C4000600	900046000	435
C4000690	72030099	412
C4000690	72030099	412
C4000747	72030078	414
C4000812	970053440	433
C4000918	900000918	254

SUPPLIER P/N	ALTEC PN	PAGE
C4000924	970053555	254
C4000925	970053521	254
C4001509	900041509	419
C4001669	900050743	414
C4001907	900040019	419
C4002364	900099613	434
C4002365	900099871	434
C4002399	970058413	433
C4002538	900002538	434
C4002568	900002568	434
C4009019	900040919	254
C4010095	970053767	439
C4011717	970053450	439
C4011720	970053768	439
C4011721	970053769	439
C4011722	970053452	439
C4012145	970053442	433
C4020023	970053676	441
C4020155	970053559	441
C4020404	970053732	440
C4020418	970053733	440
C4020421	970053734	441
C4020422	970053736	441
C4030011	970053717	440
C4030177	970053718	438
C4030291	70420132	423
C4030291	70420132	424
C4030292	900040302	423
C4030292	900040302	424
C4030293	900030293	423
C4030293	900030293	424
C4030294	900030294	423
C4030294	900030294	424
C4030295	900030295	423
C4030295	900030295	424
C4030296	900030296	424
C4030297	900030297	424
C4030298	900030298	424
C4030299	900030299	424
C4030342	900030342	424
C4030343	900030343	424
C4030613	900030613	432
C4030614	900030614	432
C4030704	900030704	432
C4030799	970053721	438
C4030814	900030814	432
C4030979	900099664	544
C4031017	900031017	427
C4031018	900031018	427
C4031019	900031019	427
C4031020	900031020	427
C4031021	900031021	427
C4031022	900031022	427
C4031022EM	970204236	426
C4031023	900031023	427
C4031029	900099665	544
C4031035	900031025	426
C4031036	900031036	426
C4031071	970053719	438
C4031085	900031085	430
C4031085M	900031086	430
C4031112	900031112	430
C4031113	900031113	430
C4031381	970155198	425
C4031382	900031382	425
C4031384	970053517	425
C4031416	900731416	435
C4031417	900740314	435
C4031597	900031597	427
C4031598	900031598	427
C4031599	900031599	427
C4031600	900031600	427
C4031601	900031601	427

SUPPLIER P/N	ALTEC PN	PAGE
C4031602	900031602	427
C4031612	900031612	432
C4031739	900031739	427
C4031822	900031822	432
C4031850	900031850	432
C4031857	900031851	432
C4032046	900032046	428
C4032046	900032046	432
C4032047	900032047	428
C4032048	900032048	428
C4032049	900032049	428
C4032050	900032050	428
C4032052	900032052	428
C4032053	900032053	428
C4032054	900032054	428
C4032055	900032055	428
C4032056	900032056	428
C4032057	900032057	428
C4032057	900032051	428
C4032058	900032058	428
C4032059	900032059	428
C4032060	900040320	428
C4032061	900032061	428
C4032062	900032062	428
C4032062	900032062	432
C4032063	900032063	428
C4032064	900032064	428
C4032065	900032065	428
C4032066	900032066	428
C4032067	900032067	428
C4032068	900032068	428
C4032069	900032069	428
C4032070	900032070	428
C4032071	900032071	428
C4032072	900032072	428
C4032073	900032073	428
C4032074	900032074	428
C4032095	900032095	428
C4032096	900032096	428
C4032097	900032097	428
C4032133	900032133	428
C403-2136	900032136	430
C403-2137	900032137	430
C4032213	900044556	432
C4032600	900032600	427
C4032601	900032601	427
C4032602	900032602	427
C4032603	900032603	427
C4032604	900032604	427
C4032605	900032605	427
C4032980	900740329	306
C4033060	900033060	426
C4033061	900033061	426
C4033068	900030368	425
C4033069	900030369	425
C4033178	900099671	545
C4033220	900099673	545
C4033402	900099669	545
C4033403	900099670	545
C4060416	69296087	401
C4060416	69296087	402
C4170346	900741703	222
C6000000	970053462	402
C6000085	970490578	395
C6000197	900060197	395
C6000197	900060197	399
C6000434	69296147	398
C6001734	81100158	399
C6001735	970040203	400
C6001754	900061754	398
C6001783	970490390	395
C6001959	69296106	398
C6002100	970037339	400

SUPPLIER P/N	ALTEC PN	PAGE
C6002100	970037339	401
C6002101	900002101	401
C6002102	878070912	401
C6002231	69296109	400
C6002232	970040209	400
C6002255	970034630	399
C6002256	900702256	400
C6002271	69296057	398
C6002276	69296145	399
C6002281	970040195	399
C6002282	970018946	399
C6002300	893942880	401
C6002606	69296058	397
C6002607	69296059	397
C6002608	68520154	397
C6002609	900702609	397
C6002614	970040145	397
C6002615	970046133	397
C6002616	69296117	397
C6002617	970040146	397
C6002622	900002622	397
C6002623	811001060	397
C6002624	878071022	397
C6002625	811001191	397
C6002630	69296140	397
C6002631	811001059	397
C6002632	970013097	397
C6002850	970132879	403
C6002851	970066912	403
C6002852	970186561	403
C6002989	970191223	403
C6002990	900002990	403
C6002991	970186563	403
E3081321P	701300036	223
E3081434P	41480003	223
E4001568P	900001564	412
E4001568P	900001564	412
E4001569	72090302	412
E4001569	72090302	412
E4010138P	970053447	436
E4012066	970053445	436
E4012068	970053444	436
E4020099	970053766	441
E4020525	970053561	441
E4031614	900031614	432
E4032543P	900032543	424
G3369	900040090	398
G3370	69296011	402
G4754-1	970194321	401
G4758	970040135	397
G4765	970005084	397
G4775	970040136	397
GP-201	970216515	280
GP-203	970099939	280
GP-2031	970366317	280
GP-204*	970070544	280
GP209	900020900	279
GP-209	900020900	280
GP2090P	900002090	279
GP-2090P	900002090	280
GP-2090P4	970366318	280
GP-2090P9	970366319	280
GP-2091P	970366320	280
GP-2091P90	970366321	280
GP2093	900002093	279
GP-2093	900002093	280
GP-2093P	970230075	280
GP2093P-90	900020930	279
GP-2093P90	900020930	280
GP-216	970366322	280
GP221	900022100	279
GP-221	900022100	280
GP-2210	970366323	280



HUBBELL POWER SYSTEMS

HUBBELL POWER SYSTEMS

HUBBELL POWER SYSTEMS

HUBBELL POWER SYSTEMS

SUPPLIER P/N	ALTEC PN	PAGE
GP2212	900002212	279
GP-2212	900002212	280
GP-2213	970366324	281
GP-2213AR	970366325	281
GP-2214	970366326	281
GP-2215P	970366327	281
GP223	900022300	279
GP-223	900022300	281
GP-2231	970366328	281
GP-2232	970019180	281
GP-2233	900022301	281
GP-2234	970320939	281
GP-2235	970366329	281
GP-2236	970018058	281
GP-2237	970017048	281
GP-2238	970114963	281
GP-2239	970075941	281
GP-224	900002240	281
GP-2240	970366330	281
GP-2241P90	970366331	281
GP-2242	970366332	281
GP-2243	970018061	281
GP-2245	970366333	281
GP-239	970366334	281
GP240	900024000	279
GP-240	900024000	281
GP-240P1	970366335	281
GP-241P	970366336	281
GP-241P1	970366337	281
GP-241P2	970366338	281
GP-241P3	970366339	281
GP-241P90	970283351	281
GP-241PS-58	970366340	281
GP-241S	970040180	281
GP-241S3GP	970366341	281
GP-241S-58	970366342	281
GP-242P	970366343	281
GP-242P-1	970284975	281
GP-242P2	970016829	281
GP243P	970366344	281
GP3458	970269010	279
GP345812	970269014	279
H1760	900001760	429
H1760-1	900017601	429
H1760-10	900017600	429
H1760-12	900017602	429
H1760-14	900017604	429
H1760-2	900017620	429
H1760-3	900017630	429
H1760-4	900046788	429
H1760-5	900717605	435
H1760-6	900017660	429
H1761	900001761	429
H1770	900001770	429
H1790-10	900017910	429
H1790-12	900017912	429
H1790-8	900017908	429
H1876	900099667	545
H18761	970092173	545
H1876-2	900718762	544
H1876-6	970057150	544
H1876-6	970057150	544
H1876-6S	970096809	544
H1876-6S	970096809	544
H1891-2	900018912	431
H1891-3	900018913	431
H1891-5	900018915	431
H1891-6	900018916	431
H2106-4	900021064	432
H3046	900003046	429
H3046-11	900030461	429
H3046-12	900030462	429
H3046-13	900030463	429

SUPPLIER P/N	ALTEC PN	PAGE
H3046-14	900030464	429
H3046-15	900030465	429
H3046-16	900030466	429
H3046-17	900030467	429
H3046-18	900030468	429
H3046-2	900026403	429
H3046-20	900006403	429
H3046-22	900022403	429
H3046-23	900032403	429
H3046-24	900042640	429
H3046-5	900056403	429
H3046-6	900066403	429
H3046-7	900076403	429
H3046-8	900086403	429
H3046-9	900096403	429
H3146-12	900021641	429
H3146-16	900061641	429
H3146-18	900081641	429
H3146-20	900002641	429
H3146-24	900042641	429
H4455	900004455	429
H4455A	900044550	429
H464612	970053356	422
H47146	970053441	433
H47163	970053373	433
H472084	970053370	433
H4722	970053374	433
H4783-22	970053456	440
H480060	900048060	419
H480072	900048072	419
H4809W	900048091	419
H4905-14	970053557	441
H4964-6W	970053562	441
HG303012	900021303	424
HG30302	900030302	424
HG30422	900030422	424
HG30425	900030425	424
LGP345812-C	970464120	279
M1846W	970053372	422
M1847	970053371	422
M1860	900001860	436
M1948-3	970053443	436
M4455-102	970053715	438
M4455-103	970053720	437
M4455-12	970053684	437
M4455-15	970053685	437
M4455-17	900744551	436
M4455-19	970053686	437
M4455-2	970053682	437
M4455-22	970053687	438
M4455-23	970053688	437
M4455-28	970053691	438
M4455-29B	900044552	432
M4455-36	970053692	438
M4455-38	970053694	437
M4455-39	970053695	438
M4455-46	900744554	435
M4455-50	970040975	435
M4455-6	970053683	436
M4455-63	970053697	436
M4455-66	900044566	432
M4455-67	900044567	435
M4455-69	900744556	436
M4455-70	900744557	436
M4455-77	970053699	438
M4455-79	970053700	440
M4455-82	970053710	437
M4455-84	900044558	435
M4455-85	900044558	435
M4455-87	970053711	440
M4455-89	900744558	435
M4455-9	900044559	432
M4455-92	970053713	440

SUPPLIER P/N	ALTEC PN	PAGE
M4455-96	970053714	437
M4660	970053678	440
M4724-1	970053454	440
M4740-3W	970088002	422
M4741-2	970053368	422
M4741-3	970053367	422
M4742	970053370	422
M48057	900048057	422
P3031215P	900099683	417
P4001594P	72030075	412
P4001594P	72030075	412
P4002536P	900002536	414
P4032996	900032996	432
P6001593	878070982	402
PSC3090323	970155355	221
PSC3090467	970052052	221
PSC3090468	970053518	221
PSC4004101	970393307	420
PSC4004102	970393314	420
PSC4004103	970393319	420
PSC4004132	970640810	433
PSC40032915	970335038	544
PSC4032935	970216792	236
PSC4033478	970246424	254
PSC4033479	970246425	254
PSC4033480	970567208	254
PSC4033484	900040334	440
PSC4170627	970194512	424
PSC4170628	970087419	424
PSC4170629	970155196	424
PSC4170638	970490581	424
PSC4170639	970490596	424
PSC4170639B	970490593	424
PSC4170640	970490601	424
PSC4170644	970155197	425
PSC6003345	970098041	403
PSC6003346	970098043	403
PSC6003347	970098044	403
PSC6003348	970186565	403
PSC6003349	970186566	403
PSC6003350	970186567	403
PSC6003412	900703412	398
PSC6003491	970490379	395
PSC6003492	970490384	395
PSC6003493	970490378	395
PSC6003494	970490376	395
PSC6010341	970106652	421
PSC6010342	970106653	421
PSC6010343	970106655	421
PSC6010344	970106657	421
PSC6010345	970106660	421
PSC6010346	970106663	421
PST4002530005	970358793	414
PST4002737	970021683	413
PST4002818	970288015	413
PST4002856	900002528	414
PST4003059	900043059	413
PST4003111	970190767	413
T3030166	900030166	417
T3031420	900099674	418
T3060006	970028250	24
T3060006	970028250	163
T3080999	970040980	224
T3080999	970040980	224
T3081506	970123853	224
T4000838	970053459	437
T4000870	970053556	423
T4001857	72090299	412
T4001937	900041937	423
T4001938	900041938	423
T4001939	900001939	419
T4001940	900001940	419
T4002415	72030116	413

SUPPLIER P/N	ALTEC PN	PAGE
T4002529	900002529	414
T4002530	900002530	414
T4030428	900000428	544
T4030856	900740308	544
T4030857	900008570	544
T4032205	900032205	427
T4032311	900099668	545
T4032557	900099666	545
T4033009	900033009	430
T403-3228	970106447	544
T4033240	970128502	427
T4033349	900033349	427
T4033350	900033350	427
T6000658	970322650	395
T6000819	970490388	395
T6000865	970048493	402
T6001549	900760015	402
T6001798	900061798	400
T6001964	970194322	401
T6001971	68321002	403
T6002320	970037530	401
T6002364	69296086	401
T6002867	970069029	401
T601-0003	900760100	397
T6010039	970107887	397
T6010040	970107890	397
V4010157	970053448	438
V4010158	970053449	438

HUSKIE

SUPPLIER P/N	ALTEC PN	PAGE
HA100-01	970366709	347
HA100-02	970366710	347
HA100-03	970366711	347
HA100-04	970366712	347
HA100-05	970366713	347
HA100-06	970366714	347
HA100-07	970366678	347
HA100-08	970366679	347
HA100-20	970366680	347
HA100-21	970366681	347
HA100-22	970366682	347
HA100-23	970366683	347
HA100-24	970366684	347
HA100-25	970366685	347
HA100-26	970366686	347
HA100-27	970366687	347
HA100-28	970366688	347
HA100-29	970366689	347
HA100-30	970366690	347
HA100-34	970366691	347
HA100-36	970366692	347
HA100-37	970366693	347
HA100-38	970366694	347
HA100-40	970366695	347
HA100-41	970366696	347
HA100-42	970366697	347
HA100-43	970366698	347
HA100-44	970366699	347
HA100-45	970366700	347
HA100-46	970366701	347
HA100-47	970366702	347
HA100-48	970366703	347
HA100-49	970366704	347
HA100-50	970366705	347
HA100-51	970366706	347
HA100-52	970366707	347
HA100-53	970366708	347
HA60-01	970244063	347
HA60-02	970325464	347
HA60-03	970062656	347
HA60-04	970203768	347
HA60-05	970366670	347

PRODUCT INDEX
BY SUPPLIER ITEM NUMBER

USA: 1-877-GO ALTEC
(1-877-462-5832)

www.alteccconnect.com



HUSKIE

SUPPLIER P/N	ALTEC PN	PAGE
HA60-06	970366671	347
HA60-07	970245678	347
HA60-08	970245680	347
HA60-09	970196314	347
HA60-20	970243939	347
HA60-21	970348322	347
HA60-22	970366661	347
HA60-23	970325468	347
HA60-24	970366662	347
HA60-25	970366663	347
HA60-26	970366664	347
HA60-27	970366665	347
HA60-28	970245674	347
HA60-29	970245679	347
HA60-30	970196315	347
HA60-40	970288008	347
HA60-41	970243945	347
HA60-42	970318143	347
HA60-43	970366666	347
HA60-44	970366667	347
HA60-45	970063083	347
HA60-46	970263657	347
HA60-47	970325470	347
HA60-48	970329131	347
HA60-49	970366668	347
HA60-50	970366669	347
HT-1116	970307922	343
HT-12	970307916	343
HT-14	970366502	343
HT-1932	970366503	343
HT-316	970366501	343
HT-38	970307920	343
HT41 BM	970366452	342
HT41 HH	970252507	342
HT4107	970366521	343
HT4108	970366522	343
HT4109	970366523	343
HT4111	970366524	343
HT4120	970366525	343
HT4128	970366526	343
HT4129	970366527	343
HT4130	970366528	343
HT4131	970366529	343
HT4132	970366530	343
HT4140	970366531	343
HT4141	970291519	343
HT4142	970288718	343
HT4155	970366532	343
HT4156	970366533	343
HT4180	970366534	343
HT41AB	970366538	344
HT41AE	970277792	345
HT41AE	970277792	346
HT41AF	970366539	344
HT41AG	970366540	344
HT41AJ	970210831	344
HT41AK	970366541	344
HT41AM	970366542	344
HT41AT	970366434	342
HT41AT	970366434	345
HT41AU	970366436	342
HT41AU	970366436	345
HT41AV	970366580	345
HT41AW	970366438	342
HT41AW	970366438	345
HT41AX	970366439	342
HT41AX	970366439	345
HT41AY	970366441	342
HT41AY	970366441	345
HT41AZ	970366443	342
HT41AZ	970366443	345
HT41BA	970366444	342
HT41BA	970366444	345

HUSKIE

SUPPLIER P/N	ALTEC PN	PAGE
HT41BC	970366446	342
HT41BC	970366446	345
HT41BE	970366448	342
HT41BE	970366448	345
HT41BF	970366450	342
HT41BF	970366450	345
HT41BJ	970302334	342
HT41BJ	970302334	345
HT41BK	970366451	342
HT41BK	970366451	345
HT41BL	970302332	342
HT41BL	970302332	345
HT41BM	970366452	345
HT41BP	970366453	342
HT41BP	970366453	345
HT41BX	970366543	344
HT41BZ	970366544	344
HT41CB	970366545	344
HT41CD	970366546	344
HT41CE	970366547	344
HT41CF	970366548	344
HT41CG	970366549	344
HT41CJ	970366550	344
HT41CK	970366551	344
HT41CL	970366552	344
HT41CT	970366553	344
HT41CUT	970220062	345
HT41DE	970366554	344
HT41DF	970366555	344
HT41DG	970366556	344
HT41DH	970366557	344
HT41DL	970366558	344
HT41DM	970366559	344
HT41DP	970366560	344
HT41DT	970366561	344
HT41DV	970366562	344
HT41DW	970366563	344
HT41DY	970366564	344
HT41DZ	970366565	344
HT41EK	970366566	344
HT41EX	970366445	342
HT41EX	970366445	345
HT41EY	970366447	342
HT41EY	970366447	345
HT41EZ	970252499	342
HT41EZ	970252499	345
HT41FA	970252504	342
HT41FA	970252504	345
HT41FB	970179343	342
HT41FB	970179343	345
HT41FG	970366567	344
HT41FM	970292405	344
HT41FN	970366568	344
HT41FU	970366569	344
HT41FW	970252501	342
HT41FW	970252501	345
HT41FX	970366570	344
HT41GE	970366535	344
HT41GE	970366437	342
HT41GE	970366437	345
HT41GF	970366442	342
HT41GF	970366442	345
HT41GK	970366571	344
HT41GL	970366435	342
HT41GL	970366435	345
HT41GM	970366440	342
HT41GM	970366440	345
HT41GW	970366449	342
HT41GW	970366449	345
HT41GX	970366572	344
HT41GZ	970252503	342
HT41GZ	970252503	345
HT41HG	970252509	342

HUSKIE

SUPPLIER P/N	ALTEC PN	PAGE
HT41HG	970252509	345
HT41HH	970252507	345
HT41HM	970366573	344
HT41J	970337945	344
HT41JM	970366574	344
HT41JN	970366575	344
HT41JP	970366576	345
HT41JR	970366577	345
HT41KA	970366617	346
HT41KB	900050549	346
HT41KC	970366618	346
HT41KD	970305399	346
HT41KE	970366619	346
HT41KF	970366620	346
HT41KG	970366621	346
HT41KH	970366622	346
HT41KI	970366623	346
HT41KJ	970366578	345
HT41KK	970366624	346
HT41KL	970293118	346
HT41KM	970366625	346
HT41KN	970255943	346
HT41KO	970217666	346
HT41KP	970366626	346
HT41KQ	970366627	346
HT41KR	970366628	346
HT41KS	970277802	346
HT41KT	970366629	346
HT41KU	970366630	346
HT41KV	970366631	346
HT41KX	970366632	346
HT41LG	970366579	345
HT41LJ	970252512	342
HT41LJ	970252512	345
HT41TEST	970366582	345
HT41U	970277808	346
HT41V	970366536	344
HT41X	970258853	344
HT41Y	970237501	344
HT41Z	970366537	344
HT-510	970366504	343
HT-516	970307912	343
HT-58-1	970187581	343
HT58AE	970282200	343
HT58AF	970366479	343
HT58AK	970074177	343
HT58BX	970366460	343
HT58BZ	970366461	343
HT58CB	970088975	343
HT58CD	970366462	343
HT58CE	970366463	343
HT58CF	970366464	343
HT58CG	970366465	343
HT58CM	970366466	343
HT58CUT	970282344	343
HT58DE	970366468	343
HT58DG	970366469	343
HT58DH	970366470	343
HT58DK	970366471	343
HT58DM	970366472	343
HT58DP	970366473	343
HT58DT	970366474	343
HT58DV	970366475	343
HT58DW	970366476	343
HT58G	970074179	343
HT58HK	970366478	343
HT58J	970366467	343
HT58KA	970366477	343
HT61AC	970282635	346
HT61AJ	970282633	346
HT61BP	970366633	346
HT61BR	970366634	346
HT61BU	970049720	346

HUSKIE

SUPPLIER P/N	ALTEC PN	PAGE
HT61BV	970366635	346
HT61FC	970252513	346
HT61FD	970049723	346
HT61HJ	970252516	346
HT61KX	970366636	346
HT-635	970325631	343
HT-737	970154320	343
HT-747	970154322	343
HT-781	970366500	343
HT-840	970275089	343
HT-916	970307921	343
HT-B	970366496	343
HT-D	970307899	343
HT-D3	900050094	343
HT-J	970366497	343
HT-K	970307906	343
HTK-1116	970366655	346
HTK-1-12H	970267350	346
HTK-1-18-2H	970366657	346
HTK-12	970366648	346
HTK-1-2H	970366656	346
HTK-14	970366651	346
HTK-1516	970298580	346
HTK-1-516H	900050526	346
HTK-1932	970366654	346
HTK-2932H	970324821	346
HTK-34H	970280970	346
HTK-38	970366653	346
HTK-510	970366644	346
HTK-516	970366652	346
HTK-572	970366645	346
HTK-58-1	970324836	346
HTK-635	970366646	346
HTK-727	970366647	346
HTK-737	970324815	346
HTK-747	970366649	346
HTK-781	970366650	346
HTK-840	970280967	346
HTK-916	970324831	346
HTK-BKT	970366658	346
HTK-C	970366659	346
HTK-D	970185597	346
HTK-N	970191672	346
HTK-O	970185598	346
HTK-P	970366660	346
HTK-U	970280966	346
HT-O	900050096	343
HT-P	970366498	343
HT-T	970366499	343
PU15	970122871	346

SUPPLIER P/N	ALTEC PN	PAGE
	970571428	377
	900096198	378
	970331734	378
	970353862	378
	970353767	378
	900096212	378
	970353806	378
	970308570	378
	900004001	378
	900070646	378
	900096214	379
	900050193	379
	900096219	379
	900096197	379
	900096210	379
	36030013	379
	900096199	379
	900096216	379
	970017137	379

HYDRAULIC TOOL ASSEMBLIES

IDEAL

SUPPLIER P/N	ALTEC PN	PAGE
T5-600-USA	970104690	554
35-688	970640801	257
35-9108	970640800	257
38-500	970184350	165
35-076	970640805	307
35-077	970640804	307
35-078	970065232	307
35-520	970184351	307
36-311	970184084	307
36-314	970640806	307

IGLOO

SUPPLIER P/N	ALTEC PN	PAGE
421	68500012	28
431	68500025	28
43295	970601307	137
44266	970451745	137
44266	970451745	137
44667	970601305	137
44677	970469112	139
45071	970307118	139
48153	68500015	137
48154	900000213	137
48228	970588798	137
48513	68500015	28
48514	900000213	28

JAMESON

SUPPLIER P/N	ALTEC PN	PAGE
10-316-200	970246843	488
11-38-1000M	970246842	488
11A-25-600M	970192885	488
12-516-300	970159296	489
12A-516-500	970269658	489
13-716-1000	970204511	489
13-716-800	970204510	489
15-316-150	970203579	489
15-316-300	970203582	489
17-100R	970637202	489
17-300R	970637201	489
17-500T	970637203	489
24-02	878010489	133
24-03	981702798	133
24-03F	809500204	128
24-03F	809500204	133
24-04	813000428	133
24-12A	970092607	128
24-12A	970092610	133
24-12AH	970092610	128
24-12AH	970092610	128
24-15D	900002415	133
24-17	970097916	133
24-25	970184534	133
6-14-300M	970257150	488
8-18-150K	970159287	488
9A-25-400M	970203577	488
BL-10	970516612	576
BL-10BM	970516624	576
BL-10F	970516616	576
BL-10M	970516620	576
BL-10SFP	970516628	576
BL-12	970516613	576
BL-12BM	970516625	576
BL-12F	970516617	576
BL-12M	970516621	576
BL-12SFP	970516629	576
BL-6	970516610	576
BL-6BM	970516622	576
BL-6F	970516614	576
BL-6M	970516618	576
BL-6SFP	970516626	576
BL-8	970516611	576
BL-8BM	970516623	576

JAMESON

SUPPLIER P/N	ALTEC PN	PAGE
BL-8F	970516615	576
BL-8M	970516619	576
BL-8SFP	970516627	576
FG-6PKG1	970141786	575
FG-6PKG2	970141789	575
JE-10	970516634	576
JE-10BM	970516652	576
JE-10F	970516640	576
JE-10M	970516646	576
JE-10S	970516658	576
JE-10SFP	970516670	576
JE-10SHF	970516664	576
JE-12	970516635	576
JE-12BM	970516653	576
JE-12F	970516641	576
JE-12M	970516647	576
JE-12S	970516659	576
JE-12SFP	970516671	576
JE-12SHF	970516665	576
JE-3	970516630	576
JE-3BM	970516648	576
JE-3F	970516636	576
JE-3M	970516642	576
JE-3S	970516654	576
JE-3SFP	970516666	576
JE-3SHF	970516660	576
JE-4	970516631	576
JE-4BM	970516649	576
JE-4F	970516637	576
JE-4M	970516643	576
JE-4S	970516655	576
JE-4SFP	970516667	576
JE-4SHF	970516661	576
JE-6	970516632	576
JE-6BM	970516650	576
JE-6F	970516638	576
JE-6M	970516644	576
JE-6S	970516656	576
JE-6SFP	970516668	576
JE-6SHF	970516662	576
JE-8	970516633	576
JE-8BM	970516651	576
JE-8F	970516639	576
JE-8M	970516645	576
JE-8S	970516657	576
JE-8SFP	970516669	576
JE-8SHF	970516663	576
SB5U	970212164	575
TP-12F	970212165	575
TP-12PKG1	970141790	575

KEARNEY - COOPER POWER TOOLS

SUPPLIER P/N	ALTEC PN	PAGE
26992	970048213	343
26993	970056664	343
26994	970045270	343
30041	970087841	343
30042	970048209	343
30084	970083109	343
30124	970048203	343
30154	970048204	343
30450	970087839	343
30554	970087830	343
30611	970087835	343
30914	970043336	343
36181	970084210	343
36457	705300770	346
36459	705300771	346
36467	818000214	346
36472	970265795	346

KEARNEY - COOPER POWER

SUPPLIER P/N	ALTEC PN	PAGE
36474	970182893	346
36476	705300782	346
36478	705300781	346
36480	705300779	346
36482	705300777	346
36484	705300790	346
36486	705300789	346
36488	705300788	346
36490	705300787	346
36494	705300786	346
36496	705300785	346
36498	705300784	346
36828	705300773	346
36830	705300769	346
36832	705300768	346
36834	705300780	346
36836	705300776	346
36838	705300775	346
40063	705300778	346
40114	970087842	343
40151	705300791	346
40493	970087837	343
40495	970087834	343
48410	970087832	343
49435	705300793	346
49437	705300794	346
100399	705300796	346
100433	970317528	346
100600	970095151	343
100601	970369804	343
100602	970095162	343
100434	705300799	346
100400	970024788	346

KH INDUSTRIES

SUPPLIER P/N	ALTEC PN	PAGE
475-20	68435038	195
675-20	705201715	195
775-20	810001061	195
CCG-515-A	970588744	155
CCG-515-B14Y	970588745	155
CCG-520-A	970588747	155
CCG-520-Y12U	970588748	155
CCG-520-Y12V	970588749	155
CCN-515-Y14Y	970588746	155
CCN-520-B12V	970588750	155
GX3M-BG-16TA	970346669	196
KH200-00057	970346665	193
KH200-00057	970346665	195
KH200-00059	970342629	195
KH200-00754	970346666	193
KH200-00754	970346666	195
KH200-134	717320205	195
NR2C-H	970487026	195
NR2C-W	970487027	193
NR2C-W	970487027	195
NR3C-1C100	970588705	195
NR3C-1C100-DD	970505175	195
NR3C-1C100-DS	970505163	195
NR3C-1C100-HS	970505176	195
NR3C-1C100-MD	970505168	195
NR3C-1C100-MS	970505164	195
NR3C-1C100-WD	970487025	195
NR3C-1C100-WS	970491627	195
NR4C-1C100	970588704	195
NR4C-1C100-DD	970505174	195
NR4C-1C100-DS	970505162	195
NR4C-1C100-HS	970505177	195
NR4C-1C100-MD	970505169	195
NR4C-1C100-MS	970505165	195
NR4C-1C100-WD	970487018	195
NR4C-1C100-WS	970491626	195
NR4S-1D050	970588702	195
NR4S-1D050-DD	970505173	195

KH INDUSTRIES

SUPPLIER P/N	ALTEC PN	PAGE
NR4S-1D050-DS	970505161	195
NR4S-1D050-HS	970505179	195
NR4S-1D050-MD	970505171	195
NR4S-1D050-MS	970505167	195
NR4S-1D050-WD	970487014	195
NR4S-1D050-WS	970491624	195
NR4S-1H130	970588703	195
NR4S-1H130-DD	970505172	195
NR4S-1H130-DS	970505160	195
NR4S-1H130-HS	970505178	195
NR4S-1H130-MD	970505170	195
NR4S-1H130-MS	970505166	195
NR4S-1H130-WD	970484606	195
NR4S-1H130-WS	970491625	195
NR955-20	970235252	195
RTBA3L-WDD515-J14K	970588712	154
RTBA3L-WDD515-J16F	970588709	154
RTBA3L-WDD515-J16H	970588710	154
RTBA3L-WDD515-J16K	970588711	154
RTBA3L-WW-B16F	970588706	154
RTBA3L-WW-B16H	970603132	154
RTBA3L-WW-B16K	970588707	154
RTBB3LW-1DD520-H12F	970588721	154
RTBB3LW-1DD520-P12K	970588722	154
RTBB3L-WDD520-J12F	970588717	154
RTBB3L-WDD520-J12K	970588718	154
RTBB3L-WGB520-J12F	970588715	154
RTBB3L-WGB520-J12K	970588716	154
RTBB3L-WW-B12G	970588708	154
RTBB3L-WW-J12F	970588713	154
RTBB3L-WW-J12K	970588714	154
RTBB3LW-WW-H12F	970588719	154
RTBB3LW-WW-P12K	970588720	154
RTBF-PVB	970588723	155
RTFA4L-WW-B16O	970588741	155
RTFB3L-WW-B16O	970588731	155
RTFC4L-WW-B10G	970588737	155
RTFD3L-WW-B10G	970588727	155
RTFD3L-WW-B12G	970588726	155
RTFD3L-WW-B14G	970588725	155
RTFD3L-WW-B16G	970588724	155
RTFD3L-WW-B16K	970588728	155
RTFD4L-WW-B12G	970588736	155
RTFD4L-WW-B14G	970588735	155
RTFD4L-WW-B16G	970588734	155
RTFD4L-WW-B16K	970588738	155
RTFH3L-WW-B10K	970588730	155
RTFH3L-WW-B12K	970588729	155
RTFH4L-WW-B12K	970588739	155
RTFJ3L-WW-B14O	970588732	155
RTFP4L-WW-B10K	970588740	155
RTFP4L-WW-B12M	970588743	155
RTFQ3L-WW-B12O	970588733	155
RTFQ4L-WW-B14O	970588742	155
SB2-1D035-D	970601460	193
SB2-1H130-H	970601467	193
SB2-1H130-W	970603119	193
SB2C-H	970603126	193

PRODUCT INDEX
BY SUPPLIER ITEM NUMBER

USA: 1-877-GO ALTEC
(1-877-462-5832)

www.alteconnect.com

KLEIN TOOLS

SUPPLIER P/N	ALTEC P/N	PAGE
258	900000258	234
259	900000259	234
267	900000267	234
268	900000268	234
470	900000470	234
1001	970071645	286
1010	900001010	286
2214	970595336	58
3227	970640799	266
3238	970022541	266
3239	970020224	266
5104	970636622	120
5109	970516139	120
5163	900051630	268
5180	970109138	119
11045	970098588	286
11046	970098589	286
11047	970098590	286
11049	970098592	286
11053	970071128	286
11062	970071644	286
32500	970120237	262
33528	970637039	263
40016	970288947	101
40016	970288947	559
40017	970288952	101
40017	970288952	559
40018	970640782	101
40018	970640782	559
40020	970640779	101
40020	970640779	559
40021	970640780	101
40021	970640780	559
40022	970640781	101
40022	970640781	559
40080	970266779	101
40082	970266780	101
40084	970266781	101
40086	970266782	101
40205	970637112	100
40206	970637113	100
40207	970637114	100
40208	970637115	100
40209	970637116	100
40210	970637117	100
40211	970637118	100
40212	970637119	100
40213	970637120	100
40214	970637121	100
40215	970637122	100
40216	970637123	100
40217	970637109	100
40218	970637110	100
40219	970637111	100
40220	970637124	100
40221	970637125	100
40222	970637126	100
44002	970122728	268
44002	970122728	559
44005	970072338	268
44005	970072338	559
44006	970330473	268
44006	970330473	559
44008	970099480	268
44008	970099480	559
44200	970020869	268
44200	970020869	268
51829	970289116	121
63035	970185318	301
63041	900763041	301
63045	900063045	301
63050	900063050	300
63060	900063060	300

KLEIN TOOLS

SUPPLIER P/N	ALTEC P/N	PAGE
63118	900063118	301
63124	900063124	301
63130	900063130	301
63136	900063136	301
63324	900063324	301
63330	900063330	301
63336	900063336	301
63607	970330038	300
63711	970488101	300
66326	970446299	265
68202	900068202	265
68203	900068203	265
68204	900068204	265
68222	970022542	266
85076	900085076	262
221407	970595355	58
221486	970595349	58
1550-4	970060999	268
1550-44	970059789	268
1570-3	900015703	268
1571INS	970640798	263
1580-3	970640796	268
1604-10	900016041	212
1604-20	900088895	212
1604-20L	900016042	212
1611-20	900016112	212
1611-30	900016113	212
1611-40	900016114	212
1611-50	900016115	212
1613-30	900088912	211
1613-40	900016134	212
1625-20	900016252	212
1628-16	900016281	212
1628-17	900016287	212
1628-18	900016288	212
1628-40VR-U SIZE	970647510	214
1656-20	900016562	211
1656-30	900016563	211
1656-40	900016564	211
1656-50	900016565	211
1656-60	970089413	211
1659-40	900016594	212
1671-10	900016711	213
1672-10	900016712	213
1684-5	900088910	212
1684-5AT	900016597	211
1684-5F	900016846	212
1684-74	900016847	211
1685-20	900088911	213
1685-31	900016853	213
1686-10	900016861	213
1692-5	900016925	212
17022-20N	900017022	234
1802-30	970103293	235
1802-30	900018023	235
1802-30S	900018023	235
1802-30S	970100586	235
1907AR	970595350	58
1907AR	970078336	558
1907ARL	970131087	558
1945G	970128002	59
1972G	900001972	59
1972G	900001972	558
2214ARS	970595340	58
3146A	900088893	266
33525SC	970640797	263
44001-BLK	970099480	268
44001-BLK	970099480	559
443A	900000443	234
507-10	900050710	266
507-12	900050712	266
507-8	970071327	266
5104S	970219891	120

KLEIN TOOLS

SUPPLIER P/N	ALTEC P/N	PAGE
5109P	970640790	120
5109PS	970211919	120
5109S	970111323	120
5144BHB	970290208	121
5144BHB14OS	970289122	121
5144BHBB	970289121	121
5144HBS	970320676	121
5181ORA	970289120	119
51829M	970327311	121
5182BLA	970289118	119
5182BLA	970289118	559
5185ORA	970434710	119
5185ORA	970434710	559
51TOP	970640791	120
5301-18	800100017	59
5301-18	800100017	558
5301-20	900053020	59
5301-20	900053020	558
5416TC	970346650	120
5416TCP	970640792	120
55456BPL	970640793	120
600-12	900006012	262
600-4	900006004	262
600-6	900006006	262
600-8	900006008	262
602-7DD	970377682	262
603-4	900006034	262
603-6	900006036	262
63041TH	970640802	301
701-S	970100673	269
702-12	900088896	269
803-32	900080332	269
808-20	900080820	269
809-36MF	970324203	269
818-16	900081816	269
900-6	900009006	267
901-6	900000573	267
905-6	900009056	267
910-6	970041927	267
911-6	970022314	267
CL1000	970248297	549
D2000-48	900020048	264
D2000-9NE	900020009	264
D2000-9NE-INS	900092000	263
D2000-9NETH	900002009	264
D203-6	900042036	263
D203-6C	970419684	263
D203-7	900042037	263
D213-9NE	9000021393	264
D213-9NETH	900002193	264
D502-10	900050210	264
D502-12	900050212	264
D507-10	900050711	266
D507-12	900050713	266
H1802-30	970202864	235
H1802-30	900018024	235
H1802-30S	970115325	235
H268	900000269	235
J2000-9NE	900090002	264
KG-2	970159000	558
KG5295-6-6L	970158717	59
KG5295-6L	970158716	59
KG5295-7L	970158718	59
KG5295-8L	970158720	59
KG5295L	970158715	59
KN1500P-EX	900016041	215
KT155HD	970329870	265
KT155T	970232048	265
KT223X4-INS	970329889	265
KT4500	970243560	213
KT4501	970243561	213
KT4502	970243574	213
KT4600	970266351	213

KLEIN TOOLS

SUPPLIER P/N	ALTEC P/N	PAGE
KT4601	970266352	213
KT4602	970266355	213
KT4800	970266356	213
KT4801	970266357	213
KT4802	970266368	213
MM1000	970641442	549
MM500	970641368	549
NRHD	970330033	267
NRHD2	970488104	267
NRHDA	970330034	267
NRHDA2	970488106	267

KUNZ GLOVES

SUPPLIER P/N	ALTEC P/N	PAGE
148	900040010	102
148	900040011	102
148	900040012	102
390	900040022	102
390	900040023	102
390	900040024	102
400	900040007	102
400	900040008	102
400	900040009	102
956	900040004	102
956	900040005	102
956	900040006	102

LEWIS MANUFACTURING

SUPPLIER P/N	ALTEC P/N	PAGE
5118	900099465	242
5118	900099465	242
5119	900099465	242
5119	900099465	242
5120	900099465	242
5120	900099465	242
40-1000	970111027	244
40-1001	900099455	244
40-1002	970111023	244
40-1003	900099454	244
40-1004	970111029	244
40-1005	900099456	244
40-1006	970111033	244
40-1007	900099457	244
40-1008	970111035	244
40-1016	970114758	244
40-1018	900099460	244
40-1019	900099460	244
40-1020	900099460	244
40-1021	900099460	244
40-1022	900099460	244
50-1785	970113450	242
50-1785	970113450	243
50-1788	970588833	242
50-1788	900050178	243
50-1790	900050179	242
50-1790	900050179	243
50-1791	970263764	242
50-1895	900099468	241
50-1904	900099469	241
50-1910	900099470	241
50-1923	970588829	241
50-1924	970588830	241
50-1925	970410534	241
50-1926	970588832	241
50-1932	970243197	241
50-1933	970588828	241
50-1944	970588831	241
50-1945	970551049	241
50-1945	970113454	243
50-1963	970110766	241
50-1968	970465471	243

LEWIS MANUFACTURING

SUPPLIER P/N	ALTEC PN	PAGE
50-1977	970110781	241
50-1977	970110781	243
50-1983	970110795	241
50-1993	900099471	241
50-1993	970230577	241
50-1996	900099472	241
50-1996	970094961	241
50-2000	900099473	241
50-2000	970588827	241
50-2011	900099485	242
50-2012	900099486	242
50-2014	900099483	242
50-2015	900099484	242
50-2130	970588822	239
50-2219	970588809	239
50-2589	970588819	239
50-2691	970588810	239
50-2766	970588821	239
50-2919	970184660	245
50-2920	970184691	245
50-2921	970184692	245
50-2922	970184693	245
50-2923	970184701	245
50-2924	970184702	245
50-2925	970588836	245
50-2925	970184703	245
50-2926	970184704	245
50-2927	970184694	245
50-2928	970184695	245
50-2929	970184697	245
50-2930	970588834	245
50-2931	970184700	245
50-2932	970588837	245
50-2932	970184706	245
50-2933	970184707	245
50-2934	970184708	245
50-2935	970184710	245
50-2936	970184711	245
50-3020	970588814	239
50-4000	970588815	239
50-4001	970588816	239
50-4002	970588817	239
50-4003	970588818	239
50-4004	970588824	239
50-4005	970588825	239
50-4006	970588826	239
50-4007	970588835	245
50-4008	970588838	245
55-1053	970118458	240
55-1064	970588802	239
55-1065	970588803	239
55-1066	970588804	239
55-1067	970588805	239
55-1068	970588806	239
55-1069	970449848	239
55-1070	970588807	239
55-1071	970588808	239
55-1072	970588811	239
55-1073	970588812	239
55-1074	970588813	239
55-1224	970588823	239
60-1087	970118418	240
60-1089	970118415	240
60-1090	97011842	240
60-1091	970118420	240
60-1093	970118428	240
60-1094	970118429	240
60-1095	970118425	240
60-1096	970118440	240
60-1097	970118442	240
60-1098	970118434	240
60-1098	970118454	240
60-1099	970118455	240
60-1103	970118462	240

LEWIS MANUFACTURING

SUPPLIER P/N	ALTEC PN	PAGE
60-1104	970118541	240
60-1105	970118543	240
60-1106	970118460	240
60-1107	970118598	240
60-1108	970118611	240
60-1109	970118597	240
60-1110	970118544	240
60-1111	970118600	240
60-1112	970118607	240
60-1113	970118613	240
60-1114	970118754	240
60-1115	970118599	240
60-1118	970118761	240
60-1119	970118762	240
60-1120	970118765	240
60-1121	970118773	240
60-1122	970118774	240
60-1123	970118759	240
60-1416	970118457	240
60-1493	970588820	239
70-1006	900099474	242
70-1007	900099475	242
70-1010	900099476	242
70-1011	900099477	242
70-1014	900099478	242
70-1015	900099479	242
90-2000	970588839	246, 527
90-2001	970588840	246, 527
90-2002	970588841	246, 527
90-2003	970588845	246, 527
90-2004	970588846	246, 527
90-2005	970588847	246, 527
90-2006	970588842	246, 527
90-2007	970588843	246, 527
90-2008	970588844	246, 527
90-2009	970588848	246, 527
90-2010	970588849	246, 527
90-2011	970588850	246, 527
90-2015	970588851	246, 527
90-2016	970588852	246, 527
90-2017	970588853	246, 527
90-2018	970588854	246, 527
90-2019	970588855	246, 527
90-2020	970588856	246, 527
90-2021	970588857	246, 527
90-2022	970588858	246, 527
90-2023	970588859	246, 527
90-2024	970588860	246, 527
90-2025	970588861	246, 527
90-2026	970588862	246, 527
90-2027	970588863	246, 527
90-2028	970588864	246, 527
90-2031	970594905	247
DLE-LK-DW-11/2-2	970184707	245
DLE-LK-DW-11/4-11/2	970588837	245
DLE-LK-DW-1-11/2	970184706	245
DLE-LK-DW-21/2-3	970184710	245
DLE-LK-DW-2-21/2	970184708	245
DLE-LK-DW-3-4	970184711	245
DLE-LK-DW-4-5	970588838	245
DLE-LK-SW-1/4-3/4	970184701	245
DLE-LK-SW-11/2-2	970184704	245
DLE-LK-SW-11/4-11/2	970588836	245
DLE-LK-SW-1-11/2	970184703	245
DLE-LK-SW-3/4-1	970184702	245
HD-0	970111027	244
HD-00	970111023	244
HD-00-S	900099454	244
HD-0-S	900099455	244
HD-0-S-Z	900099460	244
HD-1	970111029	244
HD-1-S	900099456	244
HD-1-S-Z	900099460	244
HD-2	970111033	244

LEWIS MANUFACTURING

SUPPLIER P/N	ALTEC PN	PAGE
HD-2-S	900099457	244
HD-2-S-Z	900099460	244
HD-3	970111035	244
HD-3-S-Z	900099460	244
HD-4-S-Z	900099460	244
LKJ-1	970114758	244
LPC-S1-3L	900099474	242
LPC-S1-4L	900099475	242
LPC-S2-3L	900099476	242
LPC-S2-4L	900099477	242
LPC-S3-3L	900099478	242
LPC-S3-4L	900099479	242
OH-5W-11/4-13/4	970263764	242
OH-DW-1/4"-1/2"	970113450	243
OH-DW-1/4-1/2	970113450	242
OH-TW-1/2"-7/8"	900050178	243
OH-TW-1/2-7/8	970588833	242
OH-TW-7/8"-1	900050179	243
OH-TW-7/8-11/4	900050179	242
RDB-6x6-18	970588839	246, 527
RDB-6x6-18V	970588842	246, 527
RDB-6x6-22	970588845	246, 527
RDB-6x6-22V	970588848	246, 527
RDB-7x7-18	970588840	246, 527
RDB-7x7-18V	970588843	246, 527
RDB-7x7-22	970588846	246, 527
RDB-7x7-22V	970588849	246, 527
RDB-8x8-18	970588841	246, 527
RDB-8x8-18V	970588844	246, 527
RDB-8x8-22	970588847	246, 527
RDB-8x8-22V	970588850	246, 527
RDB-A18-6x6-18	970588851	246, 527
RDB-A18-6x6-22	970588853	246, 527
RDB-A24-6x6-18	970588852	246, 527
RDB-A24-6x6-22	970588854	246, 527
RDB-A24-7x7-18	970588855	246, 527
RDB-A24-7x7-22	970588857	246, 527
RDB-A30-7x7-18	970588856	246, 527
RDB-A30-7x7-22	970588858	246, 527
RDB-A30-8x8-18	970588859	246, 527
RDB-A30-8x8-22	970588862	246, 527
RDB-A36-8x8-18	970588860	246, 527
RDB-A36-8x8-22	970588863	246, 527
RDB-A42-8x8-18	970588861	246, 527
RDB-A42-8x8-22	970588864	246, 527
SE-LK-DW-11/2-2	970184695	245
SE-LK-DW-1-11/2	970184694	245
SE-LK-DW-2-21/2	970184697	245
SE-LK-DW-2-3	970588834	245
SE-LK-DW-3-4	970184700	245
SE-LK-DW-4-41/2	970588835	245
SE-LK-SW-1/4-3/4	970184660	245
SE-LK-SW-11/2-2	970184693	245
SE-LK-SW-1-11/2	970184692	245
SE-LK-SW-3/4-1	970184691	245
U-100-DW-TB	970588819	239
U-100-SW-TB	970449848	239
U-112-DW-TB	970588820	239
U-112-SW-TB	970588807	239
U-162-DW-TB	970588821	239
U-162-SW-TB	970588808	239
U-175-SW-TB	970588809	239
U-200-DW-TB	970588822	239
U-200-SW-TB	970588810	239
U-250-DW-TB	970588823	239
U-250-SW-TB	970588811	239
U-25-SW-TB	970588802	239
U-300-DW-TB	970588824	239
U-300-SW-TB	970588812	239
U-350-DW-TB	970588825	239
U-350-SW-TB	970588813	239
U-37-DW-TB	970588815	239
U-37-SW-TB	970588803	239
U-450-DW-TB	970588826	239

LEWIS MANUFACTURING

SUPPLIER P/N	ALTEC PN	PAGE
U-450-SW-TB	970588814	239
U-50-DW-TB	970588816	239
U-50-SW-TB	970588804	239
U-62-DW-TB	970588817	239
U-62-SW-TB	970588805	239
U-75-DW-TB	970588818	239
U-75-SW-TB	970588806	239
X-A-DW-24	900099468	241
X-B-TW-32	900099469	241
X-C-TW-38	900099470	241
X-D-TW-46	900099471	241
X-E-TW-52	900099472	241
X-F-TW-58	900099473	241
X-HDFE-1/2-7/8	970243197	241
X-HDFE-1/4-1/2	970588828	241
X-HDFE-13/8-2	970588829	241
X-HDFE-2-23/4	970588830	241
X-HDFE-23/4-31/2	970410534	241
X-HDFE-31/2-41/4	970588831	241
X-HDFE-41/4-5	970588832	241
X-HDFE-7/8"-1	970113454	243
X-HDFE-7/8"-1	970113454	243
X-HDFE-7/8-13/8	970551049	241
XS-A-DW-24	970110766	241
XS-A-SW-24	970465471	243
XS-B-TW-26	970110781	241
XS-B-TW-26	970110781	243
XS-C-TW-32	970110795	241
XS-D-TW-46	970230577	241
XS-E-TW-52	970094961	241
XS-F-TW-58	970588827	241
XS-JL-100-R	900099485	242
XS-JL-125-R	900099486	242
XS-JL-25-R	900099483	242
XS-JL-50-R	900099484	242

LINCOLN HOIST

SUPPLIER P/N	ALTEC PN	PAGE
2W10	970366360	226
2W10B	970347076	226
2W10HB	970366363	226
2W10S	970366361	226
2W10SB	970366362	226
2W10SHB	970366364	226
2W10SU	970366366	226
2W10U	970366365	226
3W08	970366376	227
3W08B	970366378	227
3W08HB	970366380	227
3W08S	970366377	227
3W08SB	970366379	227
3W08SHB	970366381	227
3W08SU	970366383	227
3W08U	970366382	227
3W08	970366367	226
3W08B	970366368	226
3W08HB	970366369	226
3W08S	970344625	226
3W08SB	970345705	226
3W08SHB	970366370	226
3W08SU	970366372	226
3W08U	970366371	226
3W15	970387524	226
3W15B	970389357	226
3W15HB	970389359	226
3W15U	970389358	226
4W12	970347075	226
4W12HB	970366374	226
4W12U	970366375	226
A10S	970090213	536
A-30S	970389356	536

LINK MANUFACTURING

SUPPLIER P/N	ALTEC PN	PAGE
6060AB00	970359397	151
6060AG00	970359383	151
6060BB00	970359426	151
6060BG00	970359411	151
6065AB00	970359398	151
6065AG00	970359384	151
6065BB00	970359427	151
6065BG00	970359412	151
6070AB00	970359399	151
6070AG00	970359385	151
6070BB00	970359428	151
6070BG00	970359413	151
6075AB00	970359400	151
6075AG00	970359386	151
6075BB00	970359429	151
6075BG00	970359414	151
6080AB00	970359401	151
6080AG00	970359387	151
6080BB00	970359430	151
6080BG00	970359415	151
6085AB00	970359402	151
6085AG00	970359388	151
6085BB00	970359431	151
6085BG00	970359416	151
6090AB00	970359403	151
6090AG00	970359389	151
6090BB00	970359432	151
6090BG00	970359417	151
6095AB00	970359404	151
6095AG00	970294264	151
6095BB00	970359433	151
6095BG00	970359418	151
6100AB00	970293019	151
6100AG00	970359391	151
6100BB00	970359434	151
6100BG00	970359419	151
6105AB00	970249912	151
6105AG00	970359392	151
6105BB00	970270709	151
6105BG00	970359420	151
6110AB00	970359407	151
6110AG00	970209369	151
6110BB00	970359436	151
6110BG00	970359421	151
6115AB00	970359408	151
6115AG00	970359394	151
6115BB00	970359437	151
6115BG00	970359422	151
6120AB00	970250371	151
6120AG00	970359395	151
6120BB00	970359438	151
6120BG00	970359423	151
6125AB00	970359410	151
6125AG00	970359396	151
6125BB00	970359439	151
6125BG00	970359424	151
6130BB00	970359440	151
6130BG00	970359425	151

LITTLE GIANT

SUPPLIER P/N	ALTEC PN	PAGE
15130-001	970385350	115
15131-001	970385351	115
15143-001	970385346	115
15145-001	970385383	115
15147-001	970385348	115
15520-175	970637307	114
15524-175	970637308	114
15528-175	970637309	114
15532-175	970637310	114
15605-179	970637301	114
15605-195	970637303	114
15609-008	970385332	114

LITTLE GIANT

SUPPLIER P/N	ALTEC PN	PAGE
15609-195	970637305	114
15618-008	970385284	114
15618-195	970637304	114
15619-008	970449493	114
15619-195	970377970	114
15620-008	970637302	114
15620-195	970637306	114
15621-179	970637311	114
15621-195	970637313	114
15621-199	970637318	114
15626-179	970638584	114
15626-195	970637314	114
15626-199	970637319	114
15627-009	970385340	114
15627-195	970637315	114
15627-199	970637320	114
15628-009	970385345	114
15628-195	970637316	114
15628-199	970637321	114
15629-009	970637312	114
15629-195	970637317	114
15629-199	970637322	114
18503-240	970637323	115
18509-240	970637324	115
18515-240	970637325	115

LOWELL CORPORATION

SUPPLIER P/N	ALTEC PN	PAGE
50	970069027	283
51	970072877	283
52	900052000	283
53	900053000	283
150	970072876	283
151	970072878	283
101T	970243792	283
101TDE	970274857	282
103TDE	970274860	282
104T	970568596	283
105T	970568598	283
150T	900015000	283
151T	900011610	283
15201-95823	900015200	283
152T	900015200	283
21-84940-H001	970568599	283
21-01118-0000	970568594	282
21-T8T29-0000	970568590	282
21-T8T29-0100	970568588	282
23075099900- 23075099903	970243792	283
23-26908-9900	970324176	282
23-26908-9905	970324177	282
23-26908-9907	970324178	282
23-27810-9900	970568595	282
50901-94720	970069027	283
50901-94800	900050000	283
50T	900050000	283
51901-94720	970072876	283
51901-94800	900011600	283
51T	900011600	283
52901-95823	900052000	283
53901-95823	900053000	283
87901-94720	970072877	283
88901-94720	970072878	283
88901-94800	900011610	283
88901-94800	900015000	283
6105AB00	970249912	151
6105AG00	970359392	151
6105BB00	970270709	151
6105BG00	970359420	151
6110AB00	970359407	151
6110AG00	970209369	151
6110BB00	970359436	151
6110BG00	970359421	151

LOWELL CORPORATION

SUPPLIER P/N	ALTEC PN	PAGE
6115AB00	970359408	151
6115AG00	970359394	151
6115BB00	970359437	151
6115BG00	970359422	151
6120AB00	970250371	151
6120AG00	970359395	151
6120BB00	970359438	151
6120BG00	970359423	151
6125AB00	970359410	151
6125AG00	970359396	151
6125BB00	970359439	151
6125BG00	970359424	151
6130BB00	970359440	151
6130BG00	970359425	151

LUFKIN / APEX

SUPPLIER P/N	ALTEC PN	PAGE
066FN	970640836	275
120P	970516580	556
120TP	970516581	556
C106PM	970516577	556
C106PMCAL	970516578	556
C106TPM	970516579	556
C120TP	970516582	556
FE050	970640835	275
FE100	900000387	275
FE100	900000387	556
FE200	970516583	556
FE300	970516584	556
PHV1312	970640833	275
LHV1425	970498474	275

LUG-ALL HOISTS

SUPPLIER P/N	ALTEC PN	PAGE
25-A	970099327	229
25-B	970109693	229
25-HB	970109699	229
25-U	970109695	229
25-UB	970109697	229
2-A	970109686	229
2-B	970109688	229
2-CA	970216488	228
2-CA-1000	970216493	228
2-CB	970216489	228
2-CB-1000	970216494	228
2-CHB	970216492	228
2-CHB-1000	970216497	228
2-CU	970216490	228
2-CU-1000	970216495	228
2-CUB	970216491	228
2-CUB-1000	970216496	228
2-HB	970109691	229
2-U	970100363	229
2-UB	970109689	229
3-A	970109701	229
3-B	970109704	229
3-CA	970216498	228
3-CB	970216499	228
3-CHB	970216502	228
3-CU	970216500	228
3-CUB	970216501	228
3-HB	970109713	229
3-U	970109705	229
3-UB	970109712	229
4-A	970109724	229
4-B	970109726	229
4-CA	970216503	228
4-CB	970216504	228
4-CHB	970216507	228
4-CU	970216505	228
4-CUB	970216506	228
4-HB	970109730	229
4-U	970100364	229
4-UB	970109728	229

MAASDAM HOISTS

SUPPLIER P/N	ALTEC PN	PAGE
A-0	970141778	225
A-100	970141783	225
A-20	970141779	225
A-50	970141780	225
WS-1	970141775	225
WS-2	970141776	225
WS-25	970141777	225

MADI

SUPPLIER P/N	ALTEC PN	PAGE
BB-1	970637555	463
DBWB-1	970584828	463
DH-1	970584823	462
DV-1	970584822	462
FRWB-1	970584829	463
LWB-1	970584830	463
PK-1	970637556	463
PSD-1	970584825	462
TP-1	970584824	462
WB-1	970584827	463

MAGNUM DIMENSIONS

SUPPLIER P/N	ALTEC PN	PAGE
ALT 12/1200N	878071067	143
ALT 12/1800N	60460006	143
ALT 12/2400N	893964100	143
ALT 12/3000N	60460002	143
ALT 12/3600N	701122131	143
ALT 12/400N	893951500	143
ALT 12/800N	701122129	143
SSI-12HF10N	970351626	143
SSI12HF15N	970215726	143
SSI-12HF3.5N	970351621	143
SSI-12HF7N	970215724	143

MAJESTIC GLOVE

SUPPLIER P/N	ALTEC PN	PAGE
91437Y-2XL	970439481	84
91437Y-3XL	970439482	84
91437Y-4XL	970439483	84
91437Y-5XL	970439484	84
91437Y-6XL	970439485	84
91437Y-7XL	970439486	84
91437Y-L	970439479	84
91437Y-M	970439478	84
91437Y-S	970439477	84
91437Y-XL	970439480	84
93417Y-2XL	970439492	84
93417Y-3XL	970439493	84
93417Y-4XL	970439494	84
93417Y-5XL	970439495	84
93417Y-6XL	970439496	84
93417Y-7XL	970439497	84
93417Y-L	970439490	84
93417Y-M	970439489	84
93417Y-S	970439488	84
93417Y-XL	970439491	84
95627Y-2XL	970637516	85
95627Y-3XL	970637517	85
95627Y-4XL	970637518	85
95627Y-5XL	970637519	85
95627Y-L	970637514	85
95627Y-M	970637513	85
95627Y-XL	970637515	85
95637Y-2XL	970637523	85
95637Y-3XL	970637524	85
95637Y-4XL	970637525	85
95637Y-5XL	970637526	85
95637Y-L	970637521	85
95637Y-M	970637520	85
95637Y-XL	970637522	85

MAJESTIC GLOVE

SUPPLIER P/N	ALTEC PN	PAGE
95658-2XL	970637551	85
95658-3XL	970637552	85
95658-4XL	970637553	85
95658-5XL	970637554	85
95658-L	970637549	85
95658-M	970637548	85
95658-XL	970637550	85
95678-2XL	970637544	85
95678-3XL	970637545	85
95678-4XL	970637546	85
95678-5XL	970637547	85
95678-L	970637542	85
95678-M	970637541	85
95678-XL	970637543	85
95761-2XL	970439504	84
95761-3XL	970439505	84
95761-4XL	970439506	84
95761-5XL	970439507	84
95761-6XL	970439508	84
95761-7XL	970439509	84
95761K-2XL	970491878	84
95761K-3XL	970491880	84
95761K-4XL	970491881	84
95761K-5XL	970491882	84
95761K-6XL	970491883	84
95761K-7XL	970491884	84
95761K-L	970491876	84
95761K-M	970491875	84
95761K-S	970491874	84
95761K-XL	970491877	84
95761-L	970439502	84
95761-M	970439501	84
95761-S	970439500	84
95761-XL	970439503	84
95811-2XL	970637530	85
95811-3XL	970637531	85
95811-4XL	970637532	85
95811-5XL	970637533	85
95811-L	970637528	85
95811-M	970637527	85
95811-XL	970637529	85
95896-2XL	970637537	85
95896-3XL	970637538	85
95896-4XL	970637539	85
95896-5XL	970637540	85
95896-L	970637535	85
95896-M	970637534	85
95896-XL	970637536	85

MAKITA INDUSTRIAL TOOLS

SUPPLIER P/N	ALTEC PN	PAGE
2107FK	970588759	388
9564P	970588760	388
BL1830	970216519	207
BL1830	970216519	207
JR3070CT	970588758	388
LXLM03	970588756	207
LXLM04	970588757	207
165245-8	970490663	336
531-290-046	970490662	336
952-010-640	970490664	336
BCV02	970490661	336
BHR202	970588783	338
BHR202Z	970588784	338
BL1830	970216519	338
BTLO61	970588769	335
BTLO61Z	970588770	335
BTLO63	970588767	335
BTLO63Z	970588768	335
BTW253	970588761	334
BTW253Z	970588762	334
DC18RC	970398248	338
DC18SE	970216796	338

MAKITA INDUSTRIAL TOOLS

SUPPLIER P/N	ALTEC PN	PAGE
DC18SF LXT	970588786	338
HCU02ZX2	970490660	336
HRH01ZX2	970588785	338
LXDT04	970454601	335
LXDT04Z	970454604	335
LXDT06	970588773	335
LXDT06Z	970588774	335
LXPH03	970398249	336
LXPH03Z	970398250	336
XAG01	970398246	337
XAG01Z	970398247	337
XBP01	970588777	337
XBP01Z	970588778	337
XBP02	970588779	337
XBP02Z	970588780	337
XPH06	970588775	336
XPH06Z	970588776	336
XRJ02	970398244	336
XRJ02Z	970398245	336
XSC01	970588781	337
XSC01Z	970588782	337
XWT01	970398242	334
XWT01Z	970398243	334
XWT04	970588765	334
XWT04Z	970588766	334
XWT05	970588763	334
XWT05Z	970588764	334

MILWAUKEE ELECTRIC TOOLS

SUPPLIER P/N	ALTEC PN	PAGE
2361-20	970551242	205
2735-20	970620113	205
48-39-0511	970198905	387
48-39-0521	970198906	387
5342-21	970199370	386
5426-21	970198903	386
6146-33	970351281	386
6147-30	970351278	386
6147-31	970351280	386
6232-21	970351292	387
6509-31	970182920	387
6536-21	970198904	386
9092-20	970155561	386
9096-20	970198851	386
2202-20	970362653	538
2205-20	970199378	538
2210-20	970362973	538
2217-20	970199377	539
2237-20	970199376	538
2260-21	970329813	539
2266-20	970216787	539
2276-21	970199372	539
2281-20	970641551	539
2282-20	970641553	539
48-22-0012	970351135	276
48-22-0223	970351136	276
48-22-0305	970351139	276
48-22-1901	970299160	276
48-22-1910	970299161	276
48-22-1985	970637281	276
48-22-2008	970351140	278
48-22-3068	970351058	277
48-22-3069	970351059	277
48-22-3108	970351049	277
48-22-3110	970351050	277
48-22-3112	970351051	277
48-22-3210	970351052	277
48-22-3212	970351055	277
48-22-3309	970351047	277
48-22-3420	970637282	278
48-22-3507	970637283	278
48-22-3510	970637284	278
48-22-4106	970351060	277

MILWAUKEE ELECTRIC TOOLS

SUPPLIER P/N	ALTEC PN	PAGE
48-22-4107	970351063	277
48-22-4108	970351066	277
48-22-5116	970637298	278
48-22-5116	970637298	278
48-22-5125	970528421	278
48-22-5125	970528421	278
48-22-5130	970637299	278
48-22-5130	970637299	278
48-22-5135	970637300	278
48-22-5135	970637300	278
49-66-4461	970637285	278
49-66-4462	970637286	278
49-66-4463	970637287	278
49-66-4464	970637288	278
49-66-4465	970637289	278
49-66-4466	970637890	278
49-66-4467	970637291	278
49-66-4468	970637292	278
49-66-4471	970637293	278
49-66-4472	970637294	278
49-66-4473	970637295	278
49-66-4475	970637296	278
49-66-4484	970637297	278
49-66-4484	970637297	278
T114MC	970355511	278
0719-22	970267016	328
0719-22	970182179	328
0725-20	970466727	328
0725-21	970182908	328
0726-20	970279136	327
0726-22	970182160	327
0729-20	970352163	328
0729-21	970182887	328
0756-20	970351844	328
0756-22	970182889	328
0779-20	970199380	327
0779-22	970183730	327
0799-20	970187404	327
0799-20	970182883	327
2429-20	970363181	322
2429-21XC	970363180	322
2456-20	970351842	322
2456-21	970351273	322
2457-20	970351837	322
2457-21	970351244	322
2472-20	970355530	322
2472-21XC	970355528	322
2510-20	970241780	332
2604-20	970355516	322
2604-22	970355515	322
2605-20	970351826	325
2605-22	970351239	325
2607-20	970637326	323
2607-22	970552334	323
2620-20	970241485	325
2620-21	970182180	325
2620-22	970280717	325
2629-20	970351823	327
2629-22	970291835	327
2653-20	970528222	324
2653-22	970398459	324
2655-20	970444189	324
2655-22	970444188	324
2657-20	970584699	324
2657-22	970584698	324
2658-20	970637328	325
2658-22	970637327	325
2659-20	970302770	324
2659-22	970230078	324
2662-20	970351811	323
2662-22	970189941	323
2665-20	970235487	323
2665-22	970189942	323
2680-20	970198849	326
2680-22	970198850	326

MILWAUKEE ELECTRIC TOOLS

SUPPLIER P/N	ALTEC PN	PAGE
2682-20	970361502	326
2682-22	970342450	326
2710-20	970232043	332
2720-20	970476471	325
2720-21	970476472	325
2720-22	970476473	325
2729-20	970587760	327
2729-21	970637329	327
2729-22	970637330	327
2730-20	970476474	326
2730-21	970476475	326
2730-22	970476476	326
2762-20	970489786	323
2762-22	970489798	323
2763-20	970489799	323
2763-22	970489800	323
2764-20	970489801	323
2764-22	970489802	323
2765-20	970489803	323
2765-22	970489804	323
2780-20	970476477	326
2780-21	970476478	326
2780-22	970476479	326
2781-20	970476480	326
2781-21	970489784	326
2781-22	970489785	326
48-00-1301	970183131	333
48-00-4782	970182172	333
48-00-4784	970182174	333
48-00-4787	970182177	333
48-00-4788	970182175	333
48-00-5015	970183121	333
48-00-5016	970183124	333
48-00-5017	970183126	333
48-11-1820	970640861	332
48-11-1822	970532400	332
48-11-1828	970182987	332
48-11-1828	970182987	332
48-11-1840	970450021	332
48-11-1841	970640866	332
48-11-1850	970640862	332
48-11-1852	970640865	332
48-11-2230	970182992	332
48-11-2830	970182989	332
48-13-5560	970198854	332
48-13-5680	970198901	332
48-13-5810	970198852	332
48-13-5930	970198853	332
48-32-4401	970250141	333
48-39-0510	970255662	328
48-39-0551	970183141	328
48-39-0572	970363182	322
48-40-4070	970343942	332
48-59-1806	970637331	332
48-59-1812	970355488	332
48-59-1840	970640863	332
48-59-1850	970640864	332
48-59-2819	970328616	332
48-62-2010	970209163	332
48-62-2030	970209164	332
48-62-2046	970183741	332
48-62-2050	970209165	332
48-62-4077	970183145	332
48-62-4081	970183144	332
48-62-4085	970183146	332
48-62-4091	970183111	332
48-66-0061	970183149	333
48-89-2801	970359438	333
49-22-4175	970183152	333
49-22-4185	970183153	333
49-94-4500	970183737	328
49-94-4520	970183733	328

PRODUCT INDEX
 BY SUPPLIER ITEM NUMBER

USA: 1-877-GO ALTEC
 (1-877-462-5832)

MOBILE DESK

SUPPLIER P/N	ALTEC PN	PAGE
SCREENOUT	970637353	149
SCREENOUTIOS	970637354	149
SCREENOUTIOSx2	970638355	149
VC-ALCS-00	970637347	148
VC-ALTDR-00	970637348	148
VC-ALTF150-00	970637349	148
VC-ALT-FLM2-00	970637352	148
VC-ALTFSD-00	970637350	148
VC-ALNTL4000-00	970637351	148

MOLEX

SUPPLIER P/N	ALTEC PN	PAGE
5030	970588887	186
8565	970588753	186
35865	970588888	238
35866	970588889	238
35880	970588890	238
35881	970588891	238
35882	970588892	238
35883	970588893	238
35884	970588894	238
35885	970588895	238
35886	970588896	238
35887	970588897	238
35898	970588899	238
35899	970588900	238
36610	970588901	238
36611	970588902	238
36612	970588903	238
36613	970588904	238
36614	970588905	238
36615	970588906	238
36640	970588907	238
36641	970588908	238
36642	970588909	238
36643	970588910	238
36644	970588911	238
36645	970588912	238
36646	970588913	238
36647	970588914	238
38897	970588898	238
323126	970588885	186
323526	970588884	186
105101303	970346660	159
1076HZ25025143	970588882	186
1076HZ25050143	970588883	186
14W47A143	970588875	159
14W47A163	970588872	159
14W47B143	970588876	159
14W47B163	970588873	159
14W47D143	970588877	159
14W47D163	970588874	159
14W47-W	970588879	159
14W47-Y	970588878	159
302SRL	970588886	186
353D	68370035	159
435D	68370154	159
8565F	970588751	186
8565F-MH	970588752	186
8565-MH	970588754	186
932D123	970064003	159
DB330	970359508	158
DB350	970588865	158
DB430	970588866	158
DB450	970588867	158
ERA4040	970588870	158
ERA4150	970588869	158
ERA4250	970588868	158
ERA4940	970588871	158
S2300-HZX025163	970588880	186
S2300-HZX050163	970588881	186

MOPECO

SUPPLIER P/N	ALTEC PN	PAGE
M99M1220	900000356	492
M99M1220X	900000357	492
MEB115M	900000361	490
MEB115P	900000362	490
MVBAC	900000372	490
MVBGE	900000373	490
MVBGEH	900000374	490
MVBGEH5	900000375	490

NASCO

SUPPLIER P/N	ALTEC PN	PAGE
1501PFO-2XL	970366241	82
1501PFO-3XL	970366242	82
1501PFO-4XL	970366243	82
1501PFO-5XL	970366244	82
1501PFO-L	970366239	82
1501PFO-M	970366238	82
1501PFO-S	970366237	82
1501PFO-XL	970366240	82
1501PFY-2XL	900070609	82
1501PFY-3XL	970350250	82
1501PFY-4XL	970366218	82
1501PFY-5XL	970366219	82
1501PFY-L	900050373	82
1501PFY-M	900050372	82
1501PFY-S	900050374	82
1501PFY-XL	900050374	82
1501TFO-2XL	970241887	82
1501TFO-3XL	970366234	82
1501TFO-4XL	970366235	82
1501TFO-5XL	970366236	82
1501TFO-L	970330725	82
1501TFO-M	970330724	82
1501TFO-S	970366229	82
1501TFO-XL	970241888	82
1501TFY-2XL	970183451	82
1501TFY-3XL	970183452	82
1501TFY-4XL	970202670	82
1501TFY-5XL	970202671	82
1501TFY-L	970183449	82
1501TFY-M	970183448	82
1501TFY-S	970221231	82
1501TFY-XL	970183450	82
1503CFO-2XL	970366247	82
1503CFO-3XL	970366248	82
1503CFO-4XL	970366249	82
1503CFO-5XL	970366250	82
1503CFO-L	970135036	82
1503CFO-M	970135034	82
1503CFO-S	970366245	82
1503CFO-XL	970366246	82
1503CFY-2XL	970183905	82
1503CFY-3XL	970183906	82
1503CFY-4XL	970366220	82
1503CFY-5XL	970314266	82
1503CFY-L	970183903	82
1503CFY-M	970183902	82
1503CFY-S	970221229	82
1503CFY-XL	970183904	82
1503JFO-2XL	970331737	82
1503JFO-3XL	970241885	82
1503JFO-4XL	970366227	82
1503JFO-5XL	970366228	82
1503JFO-L	970330722	82
1503JFO-M	970330719	82
1503JFO-S	970366221	82
1503JFO-XL	970241886	82
1503JFY-2XL	900070607	82
1503JFY-3XL	970183447	82
1503JFY-4XL	970366212	82
1503JFY-5XL	970353869	82
1503JFY-L	900050370	82
1503JFY-M	900050369	82

NASCO

SUPPLIER P/N	ALTEC PN	PAGE
1503JFY-S	970221230	82
1503JFY-XL	900050371	82
4501PFY-2XL	970366295	83
4501PFY-3XL	970366296	83
4501PFY-4XL	970366297	83
4501PFY-5XL	970366298	83
4501PFY-L	970366293	83
4501PFY-M	970366292	83
4501PFY-S	970366291	83
4501PFY-XL	970366294	83
4501TFY-2XL	970366287	83
4501TFY-3XL	970366288	83
4501TFY-4XL	970366289	83
4501TFY-5XL	970366290	83
4501TFY-L	970366285	83
4501TFY-M	970366284	83
4501TFY-S	970366283	83
4501TFY-XL	970366286	83
4503JFY-2XL	970366279	83
4503JFY-3XL	970366280	83
4503JFY-4XL	970366281	83
4503JFY-5XL	970366282	83
4503JFY-L	970366277	83
4503JFY-M	970366276	83
4503JFY-S	970366275	83
4503JFY-XL	970366278	83
5001PFY-2XL	970366263	83
5001PFY-3XL	970366264	83
5001PFY-4XL	970366265	83
5001PFY-5XL	970366266	83
5001PFY-L	970366261	83
5001PFY-M	970366260	83
5001PFY-S	970366259	83
5001PFY-XL	970366262	83
5001TFY-2XL	970366271	83
5001TFY-3XL	970366272	83
5001TFY-4XL	970366273	83
5001TFY-5XL	970366274	83
5001TFY-L	970366269	83
5001TFY-M	970366268	83
5001TFY-S	970366267	83
5001TFY-XL	970366270	83
5503JNFY-2XL	970366255	83
5503JNFY-3XL	970366256	83
5503JNFY-4XL	970366257	83
5503JNFY-5XL	970366258	82-83
5503JNFY-L	970366253	83
5503JNFY-M	970366252	83
5503JNFY-S	970366251	83
5503JNFY-XL	970366254	83

NEW ENGLAND ROPES

SUPPLIER P/N	ALTEC PN	PAGE
	970546341	565
	970546343	565
	970546345	565
	970546347	565
	970546342	565
	970546344	565
	970546346	565
	970546348	565
	970546350	565
	970546352	565
	970546354	565
	970546359	565
	970546351	565
	970546353	565
	970546355	566
	970546359	566
	970546363	566
	970546356	566

NEW ENGLAND ROPES

SUPPLIER P/N	ALTEC PN	PAGE
	970546360	566
	970546364	566
	970546367	566
	970546370	566
	970546357	566
	970546361	566
	970546365	566
	970546368	566
	970546371	566
	970546358	566
	970546362	566
	970546366	566
	970546369	566
	970546372	566
	970200479	566
	970546375	566
	970546378	566
	970546381	566
	970546384	566
	970546373	566
	970546376	566
	970546379	566
	970546382	566
	970546385	566
	970546374	566
	970546377	566
	970546380	566
	970546383	566
	970546386	566
	970546387	567
	970546389	567
	970546391	567
	970546394	567
	970546397	567
	900042558	567
	900042501	567
	970546392	567
	970546395	567
	970546398	567
	970546388	567
	970546390	567
	970546393	567
	970546396	567
	970546399	567

NICHOLSON/APEX

SUPPLIER P/N	ALTEC PN	PAGE
80263	970516567	275
80263	970516567	555
80269	970516569	275
80269	970516569	555
80299	970516566	275
80299	970516566	555
80309	970516568	555
80777	970516573	555
80799	970516574	555
80814	970516575	555
80951	970640832	275
80965	970640831	275
80975	970640830	275
02144N	970637645	274
02147N	970311171	274
02215N	970516585	556
02228B	970637647	274
02229B	970637646	274
02230B	970311173	274
02244N	970516586	556
02884M	970516587	556
02905M	970516588	556
02926M	970516589	556
21474H	970640829	274
22030HNN	970637651	274

OSH KOSH TOOLS

SUPPLIER P/N	ALTEC P/N	PAGE
199	900001999	572
200	900002000	572
201	900002010	572
480	900000480	572
573	970212271	572
577	900000577	572
576T	900000576	572
137	900001370	110
137	900001370	572
138	900001380	110
138	900001380	572
139	900001390	110
139	900001390	572
199	900001999	110
200	900002000	110
201	900002010	110
295	900000295	110
295	900000295	572
296	900000296	110
296	900000296	572
297	900000297	110
297	900000297	572
298	900000298	110
298	900000298	572
299	900000299	110
299	900000299	572
384	900000384	109
384	900000384	572
385	900000385	109
385	900000385	572
386	900000386	109
386	900000386	572
480	900000480	110
480	900000480	110
480	900000480	572
573	970212271	110
577	900000577	110
593	900000593	110
593	900000593	572
594	900000594	110
594	900000594	572
595	900000595	110
595	900000595	572
854	900000854	111
855	900000855	111
856	900000856	111
857	900000857	111
963	900000963	110
963	900000963	572
964	900000964	110
964	900000964	572
1005	900001005	108
1005	900001005	108
1006	900088933	108
1006	900088933	108
1007	900001007	108
1007	900001007	108
1008	900088931	108
1008	900088931	108
1009	900001009	108
1009	900001009	108
1054	900001054	111
1055	900001055	111
1056	900001056	111
1057	900001057	111
1061	900001061	109
1062	900001062	109
1063	900001063	109
1064	900001064	109
1065	900001065	109
1066	900001066	109
1067	900001067	109
1071	900001071	109
1072	900001072	109

OSH KOSH TOOLS

SUPPLIER P/N	ALTEC P/N	PAGE
1074	900001074	109
1075	900001075	109
2002	900002002	111
2003	900002003	111
2023	900002023	108
2024	900002024	108
2025	900002025	108
2026	900002026	108
2027	900002027	108
2032	900002032	108
2033	900002033	108
2034	900002034	108
2035	900002035	108
2036	900020326	108
2036	900002036	108
2051	900002051	111
4241	900004241	111
2003A	900020031	111
2003B	900020032	111
200-A	900700200	110
2023E	900020235	108
2024E	900020245	108
2025E	900020255	108
2026E	900020265	108
2027E	900020275	108
2033-6	900020336	108
2034-6	900020346	108
2035-6	900020356	108
2036-6	900020366	108
2050-103	900002053	111
2050-8	900002050	111
2050-9	900720509	111
2050A-8	900002058	111
2050A-9	900002059	111
2051-103	900020513	111
2051A-8	900020518	111
206-4645	970241654	110
3698-10	900036981	111
3698-7	900036987	111
3698-8	900036988	111
3698-9	900036989	111
3698-A10	900013698	111
3698-A7	900073698	111
3698A8	900083698	111
3698A9	900093698	111
384A	900003841	109
384A	900003841	572
384B	900003842	109
384B	900003842	572
384L	900003840	111
384L	900003840	111
386L	900033860	111
575T	900000575	110
575T	900000575	110
575T	900000575	572
576T	900000576	110
576T	900000576	110
576T	900000576	572
577T	900000577	110
577T	900000577	572
852-6	900008526	109
852-8	900008528	109
852-9	900008528	109

PASLODE

SUPPLIER P/N	ALTEC P/N	PAGE
219086	970135050	389
219247	970135053	389
401482	970135052	389
402500	970135047	389
816007	970380209	389
900200	970135075	389
900507	970135076	389
902536	970380210	389
8612PS-10M	970135044	389
IM2000-S16	970133105	389

PELICAN

SUPPLIER P/N	ALTEC P/N	PAGE
450	970333316	122
2360	970366386	201
2410	970365010	201
2690	970267986	201
2720	970366388	201
2760	970641339	201
9500	970424556	200
150-250-WB	970622273	138
2410PL	970267657	201
32-150Q-MC-WHT	970622265	138
32-150Q-OC-TAN	970607789	138
32-20Q-MC-WHT	970622247	138
32-20Q-OC-TAN	970622254	138
32-250Q-MC-WHT	970622268	138
32-250Q-OC-TAN	970622271	138
32-35Q-MC-WHT	970607780	138
32-35Q-OC-TAN	970607789	138
32-45Q-MC-WHT	970595187	138
32-45Q-OC-TAN	970587448	138
32-65Q-MC-WHT	970571107	138
32-65Q-OC-TAN	970622257	138
32-95Q-MC-WHT	970571108	138
32-95Q-OC-TAN	970522258	138
35-45-65-WB	970622272	138
3610-BLACK	970366389	201
3610PL	970366391	201
3610-Y	970366390	201
91410L	970640794	201
9410L	970640795	201
9430 WB BLACK	970267996	200
9430 WB YELLOW	970243104	200
9430SL	970366385	200
9460 BLACK	970309393	200
9460 SAFETY YELLOW	970366384	200
C-TD-KIT	970622274	138

PENGO

SUPPLIER P/N	ALTEC P/N	PAGE
101017	900056576	515
101019	900056581	515
101021	900056586	515
101023	900056596	515
101025	900056601	515
101027	900056606	515
101029	900056611	515
101031	900056616	515
101033	900056621	515
101035	900056626	515
101037	900056631	515
101039	900056636	515
101041	900056641	515
101043	900056646	515
101101	900009258	513
101103	900010258	513
101105	900012258	513
101107	970206888	513
101109	900016258	513
101111	900018258	513
101113	900015258	513
101115	900024258	513
101117	900030258	513
101119	900036258	513
101151	900025809	514
101153	900025812	514
101155	900025816	514
101157	900025818	514
101159	900025820	514
101161	701705033	514
101163	900025830	514
101165	900040569	514
101579	970557905	516
101581	970334379	516
101582	970335424	516
101583	970557907	516
101584	970557908	516

PENGO

SUPPLIER P/N	ALTEC P/N	PAGE
101585	900091605	516
101587	970557909	516
101588	970557910	516
101589	970557911	516
101590	970557912	516
101591	970557913	516
101592	970557914	516
101679	970040565	514
101842	900033600	514
101844	900033603	514
101846	813000720	514
101847	900037523	520
101849	900099915	520
101850	900099953	520
101851	900033606	514
101867	970557906	516
101869	900056540	516
102095	900056175	516
102170	970486652	514
102586	970246777	519
102593	970247689	519
102615	970256911	518
102634	970264423	517
102842	970358729	517
102843	970359275	517
102844	970359281	517
102845	970355069	517
102865	970586234	514
102898	970403377	514
103070	970494285	518
103071	970494301	518
103072	970494300	518
131683	970257671	523
131685	970557917	523
131726	70090123	523
131727	899408300	523
131732	70090071	521
131733	70090070	521
131770	70090066	521
131788	70090067	521
131790	70090069	521
131791	70090068	521
131854	70090065	521
131866	70090073	521
131867	70090072	521
131872	70090077	521
131873	70090076	521
131878	716302126	521
131879	716302127	521
131884	716302128	521
131885	716302129	521
131974	70090075	521
131975	70090074	521
131976	716302087	521
131977	716302088	521
132116	716302160	523
132260	70090176	523
132419	900032419	522
132477	970016074	518
132609	900032609	522
132702	900099797	522
133601	900033601	514
133602	900033602	514
133604	900033604	514
133607	900033607	516
133608	900056170	516
133609	900056180	516
133610	900056185	516
133611	970018791	516
133612	900056200	516
133613	900056215	516
133615	970040568	514
133620	970228911	516

PRODUCT INDEX
BY SUPPLIER ITEM NUMBER

USA: 1-877-GO ALTEC
(1-877-462-5832)

www.alteccconnect.com



PENGO

SUPPLIER P/N	ALTEC PN	PAGE
133621	900056160	516
133690	900056150	516
134090	970471753	526
134091	900034091	526
134705	970258602	514
134797	900034797	522
134816	70000039	522
134832	970173948	518
134850	70000043	522
134891	970255772	522
134940	970020535	518
134941	970173878	518
134942	970226183	518
134943	970310802	518
135022	70000058	522
135090	970055338	518
135762	970270789	522
135782	70000042	522
135784	70000015	522
135787	70000041	522
135789	970064034	522
135867	970363902	523
135890	70000062	522
135913	970111268	520
135913	900099000	523
136339	970254148	519
136340	970254149	519
136341	970254150	519
136343	970557915	519
136344	970247690	519
136466	900032984	522
137208	970050099	514
137208	970050099	517
137208	970050099	523
137331	970394460	523
137348	970363905	519
137348	970363905	523
137357	900037350	523
137391	970557916	522
137517	970073569	520
137518	970103788	520
137519	70090316	520
137520	70090314	520
137521	900037521	520
137522	70090315	520
137524	900037524	520
137527	900037527	520
137528	900099934	520
137529	900099935	520
137530	970124923	520
137601	700900060	526
137737	716302003	526
137750	900037750	526
140000	970405422	524
140002	970363920	519
140002	970363920	524
140005	70090063	524
140006	70090091	524
140010	970185988	518
140012	970300463	518
140015	70090229	524
140017	70090096	524
140020	70090095	524
140022	70090228	524
140029	716302096	518
140115	70009008	513
140115	70009008	524
140200	70090062	524
151100	716302107	523
151100	716302107	523
151110	70090093	523
151110	70090093	523
151275	900051273	513

PENGO

SUPPLIER P/N	ALTEC PN	PAGE
151275	900051273	523
151598	970117232	523
151598	970117232	523
151672	900011582	523
151680	716302105	523
151970	893507700	523
151970	893507700	523
154020	900054205	522
154030	970006166	522
154121	700000009	522
154141	70009011	522
154151	70090180	522
157010	716302090	524
157027	900040119	513
157027	900040119	524
157300	970369730	524
157382	70090061	523
157531	970586784	526
158110	970557919	519
158110	970557919	524
158115	970557918	524
158120	970557920	519
158120	970557920	524
170030	970117684	524
170034	716302091	524
171221	716302092	524
171231	970285762	524
171574	970357032	524
171575	900071575	524
199220	700090002	523
544233	900054233	521
553118	970291544	518
553400	900053400	522
553402	900053402	522
553403	900053403	522
554230	700090001	521
554231	700090007	521
554232	700090003	521
554240	900054240	521
554241	900054241	521
554242	900054242	521
554243	893851410	521
554320	970557899	513
554321	900054321	513
554322	970557900	513
554330	900054330	513
554331	900054331	513
554332	900054332	513
554333	970557898	513
554335	900054335	513
554338	900054338	513
554339	970557901	513
554680	900054680	516
554681	900054681	516
554682	970557902	516
554683	970284729	516
554684	900054684	516
554685	900054685	516
554686	970557903	516
554687	900054687	516
554688	970474864	516
554689	970557904	516
556500	900056500	516
556505	900056505	516
556510	900056510	516
556520	900056520	516
556525	900056525	516
556530	900056530	516
556535	900056535	516
556540	970029773	516
556545	900056545	516
556550	900056550	516
556555	900056555	516
556560	900056560	516

PENGO

SUPPLIER P/N	ALTEC PN	PAGE
556565	900056565	516
556570	900056570	516
556575	900056575	515
556580	900056580	515
556585	900056585	515
556595	900056595	515
556600	900056600	515
556605	900056605	515
556610	900056610	515
556615	900056615	515
556620	900056620	515
556625	900056625	515
556630	900056630	515
556635	900056635	515
556640	900056640	515
556645	900056645	515
850005	970538979	526
850016	70090162	525
850017	716320005	525
850022	970441568	525
850023	970491722	525
850024	970363902	525
850025	970493072	525
850027	970246659	525
850029	900000533	525
850031	70090161	525
850032	70090121	517
850032	70090121	525
850035	970365049	514
850035	970365049	517
850035	970365049	525
850037	900034053	520
850037	900034053	525
850038	970557921	525
850223	970557927	519
990001	900034061	520
990001	900034061	526
990002	900010227	526
990003	900099908	526
990029	970527715	526
990043	900034039	514
990043	900034039	517
990043	900034039	526
990082	970557922	526
1650	70090062	512
1652	70090095	512
1656	70090063	512
1658	70090091	512
1851	900051273	512
100045	70090182	511
100047	900054600	511
100053	900054560	511
100055	900054620	511
100057	70090049	511
100058	900011575	511
100103	70090183	511
100105	900054601	511
100111	70090198	511
100113	900054621	511
100115	70090050	511
100116	70090079	511
100161	70090184	511
100163	900054602	511
100170	70090194	511
100172	970586546	511
100173	70090051	511
100174	70090080	511
100219	70090185	511
100227	900054563	511
100231	70090052	511
100232	70090081	511
100277	70090186	511
100285	900054564	511
100289	70090053	511

PENGO

SUPPLIER P/N	ALTEC PN	PAGE
100290	70090082	511
100351	70090187	511
100353	900054605	511
100364	70090195	511
100366	970586556	511
100371	70090054	511
100372	70090083	511
100433	70090188	511
100435	900054606	511
100445	900054566	511
100447	900054626	511
100454	70090084	511
100515	70090189	511
100517	900054607	511
100527	70090196	511
100536	70090085	511
100581	70090190	511
100583	900054608	511
100589	70090205	511
100591	900054628	511
100593	70090057	511
100594	70090086	511
100655	70090191	511
100657	900054609	511
100657	900054609	511
100676	70090197	511
100676	70090087	511
100733	70090225	511
100734	900011576	511
100779	70090192	511
100781	900054610	511
100787	900054570	511
100789	900054630	511
100791	70090094	511
100792	900011578	511
100837	70090193	511
100839	900054611	511
100845	900054571	511
100847	900054631	511
100850	900011579	511
101853	70090056	511
101856	70090058	511
101857	70090118	511
552005	716302043	512
552010	716302044	512
552035	716302123	512
552040	716302051	512
552045	716302120	512
552050	716302054	512
552055	716302119	512
552057	900099681	512
552408	70090055	511
554764	970253205	512
554787	970557896	512
554789	970557897	512
554807	970313253	512
554809	716302173	512
FH-205	70090061	512
FH-205C	70090176	512
P-1650	70090123	512
P-1656	899408300	512

PLUMB/APEX

SUPPLIER P/N	ALTEC PN	PAGE
11428	970516591	557
11520	970516590	557
11549	970516596	557
11554	970516597	557
11649	970516592	557
11414N	970637650	274
11415N	970637649	274
11417N	970260792	274
11544P	970516595	557
11559P	970516598	557

PROTECTIVE INDUSTRIAL PRODUCTS

SUPPLIER P/N	ALTEC PN	PAGE
09-K1250-L	970444098	98
09-K1250-M	970444097	98
09-K1250-S	970444096	98
09-K1250-XL	970444099	98
09-K1250-XXL	970444100	98
120-4100-L	970444171	99
120-4100-M	970444170	99
120-4100-S	970444169	99
120-4100-XL	970444172	99
120-4100-XXL	970444173	99
120-4200-L	970444166	99
120-4200-M	970444165	99
120-4200-S	970444164	99
120-4200-XL	970444167	99
120-4200-XXL	970444168	99
148-1000	MODEL #	475
148-2000	MODEL #	475
148-2136	970492564	475
148-2142	970492662	475
148-4000	MODEL #	475
148-5000	MODEL #	475
148-6000	MODEL #	475
148-6011	970492566	475
148-6014	970470269	475
148-6016	970492567	475
148-6018	970492678	475
148-7000	MODEL #	475
151-2-18*	MODEL #	475
151-3-18	MODEL #	475
154-2-16*	MODEL #	475
154-2-18	MODEL #	475
158-1-18	MODEL #	475
158-2-18	MODEL #	475
158-3-18	MODEL #	475
158-4-18	MODEL #	475
159-2-16	MODEL #	475
159-2-18	MODEL #	475
159-3-16	MODEL #	475
159-3-18	MODEL #	475
159-4-16	MODEL #	475
159-4-18	MODEL #	475
161-2-16*	MODEL #	475
161-2-18	MODEL #	475
162-2-18	MODEL #	475
19-D622-L	970444093	98
19-D622-M	970444092	98
19-D622-S	970444091	98
19-D622-XL	970444094	98
19-D622-XS	970444090	98
19-D622-XXL	970444095	98
280-AHS150-10	970496985	25
280-AHS150-10	970496985	97
280-AHS150-10	970496986	97
280-AHS150-10 ALTEC	970496986	25
280-AHS240-10	970496987	25
280-AHS240-10	970496987	97
280-AHS240-10	970496988	97
280-AHS240-10 ALTEC	970496988	25
280-EV6121-10	970496993	25
280-EV6121-10	970496993	97
280-EV6121V-10	970496994	25
280-EV6121V-10	970496994	97
280-EV6141-10	970496989	25
280-EV6141-10	970496989	97
280-EV6141V-10	970496990	25
280-EV6141V-10	970496990	97
280-EV6151-10	970496995	25
280-EV6151-10	970496995	97
280-EV6151-10-ALTEC	970497783	25
280-EV6151-10-ALTEC	970497783	97
280-EV6151V-10	970496996	25
280-EV6151V-10	970496996	97
280-EV6161-10	970496991	25

PROTECTIVE INDUSTRIAL PRODUCTS

SUPPLIER P/N	ALTEC PN	PAGE
280-EV6161-10	970496991	97
280-EV6161V-10	970496992	25
280-EV6161V-10	970496992	97
34-845-L	970444122	99
34-845-M	970444121	99
34-845-S	970444120	99
34-845-XL	970444123	99
34-845-XS	970444119	99
34-845-XXS	970444118	99
34-874-L	970444105	99
34-874-M	970444104	99
34-874-S	970444103	99
34-874-XL	970444106	99
34-874-XS	970444102	99
34-874-XXS	970444101	99
41-1400-L	970444109	98
41-1400-M	970444108	98
41-1400-S	970444107	98
41-1400-XL	970444110	98
41-1400-XXL	970444111	98
73-1703-L	970444114	98
73-1703-M	970444113	98
73-1703-S	970444112	98
73-1703-XL	970444115	98
73-1703-XXL	970444116	98
73-1703-XXXL	970444117	98

PSE AMBER

SUPPLIER P/N	ALTEC PN	PAGE
90LBMAG	970332350	197
CL199AH	970174430	197
CL199AMH	970296411	197
L400IASMH	970332365	197
L400IATMH	970637280	197
LL400IASH	68451137	197
LL400IATH	68451161	197
LXEXB1F-AH	970014873	197
LXEXB1FW-AH	970332368	197
LXEXB1F-WH	970332372	197
LXEXB1FW-WH	970332374	197
SHL10A	970332337	197
SHL10AM	970332343	197
SHL10CA	970332342	197
SHL10CAM	970332352	197
SHL10CAW	970515542	197
SHL10CAWM	970515543	197
SMKSMB	970332362	197
TRX6A	970295623	197
TRX6AW	970296867	197
TRX6W	970295633	197
XT308AS	970186675	197
XT3AH	970332376	197
XT3WH	970222689	197

PUREGAS

SUPPLIER P/N	ALTEC PN	PAGE
M038384	900000351	490
M038385	900000352	490
M038386	900000353	490
M038387	900000354	490
M99M1220	900000356	490
M99M1310	900000358	490
M99M1710	900000359	490
MEBHP15	900000364	490

RADIANS / CROSSFIRE

SUPPLIER P/N	ALTEC PN	PAGE
241	970389013	34
921	970359544	33
1528	970376106	34
1528	970376106	34
1541	970359552	33

RADIANS / CROSSFIRE

SUPPLIER P/N	ALTEC PN	PAGE
1541	970359552	34
2117	970312224	32
2117	970312224	34
2123	970359520	32
2243	970388640	34
2244	970388639	34
2254	970388645	34
2812	970359534	32
2961	970359521	32-35
3469	970278539	33
9117	970359539	33
15117	970369604	34
16428	970438445	34
18146	970359554	33
18146	970359554	34
21126	970369602	34
21427	970350249	32
21427	970350249	34
22528	970388642	34
23226	970312227	33
23226	970312227	34
23233	970359560	33
24426	970354254	33
24426	970354254	34
29117	970359527	32
29117	970359527	34
161129	970438457	34
211125	970359518	32-35
2444AF	970359565	33
2461AF	970359562	33
2761AF	970278540	32
2761AF	970278540	34
821AF	970359546	33
844AF	970359548	33

RAINBOW TECHNOLOGIES

SUPPLIER P/N	ALTEC PN	PAGE
4060	970081625	165
4022	970081340	105
4214	970568798	107
4305	970169607	107
4410	970211555	107
4480	970089232	107
4483	970089239	107
4501	970081627	105
4507	970211568	105
4508	970211566	105
6250	970583999	104
6251	970584003	104
6276	970583981	104
6277	970583993	104
7152	970211567	105
40230	970569567	105
40590	970568817	106
42142	970096295	107
42147	970568815	107
79315	970211570	105
79316	970211573	105
79511	970568813	106
79526	970568816	106
79702	970081317	106
79703	970081325	106
79705	970081329	106
79706	970081331	106
79707	970081333	106
79709	970081334	106
87020	970169618	107
88500	970081337	105
4214-1	970568800	107
4214-5	970568802	107
4214-55	970568803	107
	970568821	106

RAUCKMAN UTILITY PRODUCTS

SUPPLIER P/N	ALTEC PN	PAGE
BW-044	970326748	284
BW-203HD	900050157	284
BW-223HD	900002230	284
BW-244	970326751	284
BW-251	900002510	284
M-001,	970184714	460
M-002A,	970184715	460
M-009	970184718	460
R-TD	970184719	460
R-TD2	970184720	460

REELTECH

SUPPLIER P/N	ALTEC PN	PAGE
	818000620	157
	970065320	157

RIPLEY

SUPPLIER P/N	ALTEC PN	PAGE
34230	900099564	293
35150	970101186	291
35150	970101186	292
35250	900099561	293
35900	970101185	291
35900	970101185	292
36312	970101200	291
37296	970264591	291
37296	970264591	292
38750	970103592	291
2 X 2 Plus Tool*	970052003	293
4 x 4 Plus Tool*	900736001	293
700FP	900000537	293
BP1A	900099562	291
BP1A	900099562	293
BP2A	900099563	293
BP3A	970127533	293
CB 7-2	970089541	292
CPK-1	970055796	291
WS 22	970101190	292
WS 5A-DA	970103592	292
WS 68 (37430)	970060374	292
WS22A 22A with 1/2" Square Socket Drive	970101197	291
WS22A with 1/4" Hex Drive	970101192	291
WS22A with 3/8" Drill Drive	970101191	291
WS22A with 3/8" Square Socket Drive	970101196	291
WS-5A	900037415	292
WS68SNAP	970089411	291

RUEGG

SUPPLIER P/N	ALTEC PN	PAGE
100-1	970162915	236
POLE ROLLER	970162916	236
SLAP-ON #2 PLAIN	970162914	236

SALISBURY

SUPPLIER P/N	ALTEC PN	PAGE
21	900002121	469
1300	900001300	469
1302	970081049	469
1304	970081053	469
1451	900000418	481
1460	900000419	481
1461	900000420	481
2500	970093070	553
2500	970093070	553
4244	970106454	553
4315	970067482	553
4315	970067482	553
4344	970106455	553
4356	900099676	469

PRODUCT INDEX
 BY SUPPLIER ITEM NUMBER

USA: 1-877-GO ALTEC
 (1-877-462-5832)

www.alteccconnect.com



SALISBURY

SUPPLIER P/N	ALTEC PN	PAGE
4356	900099676	553
4367	900704367	469
4367	900704367	553
4444	970055973	553
4445	900099678	553
4469	900704469	469
4469	900704469	553
4544	970106448	553
4556	900099677	553
4644	970106449	553
4667	970106450	553
4744	970089931	553
4769	900004769	553
21116	970081055	468
21172	900021172	468
21315	900021315	468
21644	970081058	468
10-4	900010461	481
20-260	900040038	480
21116TC	970081056	468
23-250	900040034	480
23-270	900040042	480
24-273	970071579	480
3412-SC	970081065	468
38-12SC	970081061	468
38-50SC	970081059	468
51509-10	970080835	480
51509-11	970080836	480
51509-12	970080837	480
51509-9	970080831	480
51530-10	970080841	480
51530-11	970080842	480
51530-12	970080843	480
51530-9	970080840	480
58-12SC	970081062	468
900E	900009000	469
B1	900045648	469
B-2	900020521	480
B22	970080101	480
GB114	970080008	480
GB116	970080092	480
GB118	970080094	480
GPB114	970254647	480
GPB118	970247387	480
H-1	900011168	480
HS21	970081039	469
ILP7C	MODEL #	479
ILPG10	MODEL #	479
ILPG10A	MODEL #	479
LP7C	MODEL #	479
LPG3S	MODEL #	479
LPG5S	MODEL #	479
OR125-3	900001253	468
OR125-3C	900012530	468
OR125-45	900012545	468
OR125-45C	970463953	468
OR125-6	900001256	468
OR125-6C	970076912	468
OR150-3	970106332	468
OR150-6	970097409	468
OR150-6C	900015060	468
ORC125	900001250	468
P6	900064551	469
S0190L0048	970222638	249
S0191L0048	900019148	249
S0194L0048	970304492	249
S1	900011542	480
S4	900000421	481
S5	900000422	481
T31	900031000	480
T32	970080097	480
UWG-HUXT/L	970081004	103
UWG-HUXT/M	970080999	103
UWG-HUXT/S	970080990	103

SALISBURY

SUPPLIER P/N	ALTEC PN	PAGE
UWG-HUXT/XL	970081009	103
UWG-HUXT/XXL	970081010	103
UWG-KLG/L	970080963	103
UWG-KLG/M	970080948	103
UWG-KLG/S	970080945	103
UWG-KLG/XL	970080969	103
UWG-KLG/XXL	970080970	103
UWG-WPGC/L	970080929	103
UWG-WPGC/M	970080928	103
UWG-WPGC/S	970080927	103
UWG-WPGC/XL	970080930	103
UWG-WPGC/XXL	970080931	103
UWG-WPSC/L	970080940	103
UWG-WPSC/M	970080933	103
UWG-WPSC/S	970080932	103
UWG-WPSC/XL	970080941	103
UWG-WPSC/XXL	970080943	103

SAMSON ROPES

SUPPLIER P/N	ALTEC PN	PAGE
346032001260	970545627	564
346032001560	970545628	564
346032006030	970545631	564
346040001560	970545629	564
346040006030	970545632	564
346048001530	970545630	564
346048006030	970546533	564
348032101260	970545610	564
348032101560	970545616	564
348032102060	970545622	564
348032106030	970545625	564
348032801260	970545611	564
348032801560	970545617	564
348032802060	970545623	564
348032806030	970545626	564
348032901260	970545609	564
348032901560	970545615	564
348032902060	970545621	564
348032906030	970545624	564
806032801560	970545634	564
806032806030	970545638	564
806040401560	970545637	564
806040406030	970545636	564
806048601560	970545635	564
806048606020	970545639	564
3480321156100	970545613	564
3480321206100	970545619	564
3480328156100	970545614	564
3480328206100	970545620	564
3480329156100	970545612	564
3480329206100	970545618	564
34803210126100	970545607	564
34803280126100	970545608	564
34803290126100	970545606	564
915-321	23421054	534

SHERMAN & REILLY

SUPPLIER P/N	ALTEC PN	PAGE
600080	970514308	256
600080	970603051	256
600081	970514309	256
600081	970603056	256
600082	970603045	256
600082	970603055	256
600083	970603048	256
600083	970603054	256
700211	970603073	256
700211	970055852	256
700423	970050838	256
700438	970347081	256
700438	970603069	256
700447	970353165	256
700597	970402150	256
700860	970402151	256

SHERMAN & REILLY

SUPPLIER P/N	ALTEC PN	PAGE
700860	970402151	256
701134	970050843	256
S-85-SR	970364229	256
SST-7585	970364226	256
SST-7585	970485292	256

SIEVERT

SUPPLIER P/N	ALTEC PN	PAGE
309133	970047736	384
3015-04	970047737	384
3341-47	970047733	384
3366-97	970047734	384

SPEED SYSTEMS

SUPPLIER P/N	ALTEC PN	PAGE
1562	970089139	290
1562	970089139	293
1581	970089140	290
1581	970089140	293
1678	970089137	293
1700	970120109	290
2750	970101335	290
2781	970373152	290
2900	970380673	290
1542-2CL	900715422	290
1542-2CL	900715422	293
1700SS	900701700	293
1700-SS	900701700	290
1700-SS-LC	900070222	290
1800SS	970057167	293
2900S	970637340	290
BIT/E180AH	970637343	461
BIT/E180AT	970073103	461
BIT/TK120X-N	970637342	461
BIT/TK120X-Q	900000525	461
FIIT/TK120X	900000526	461
LPW1525	970347280	461
LPW1525/TK120X	970637344	461
LPW1525/TK120X-N	900015251	461
Mark I	970637338	290
Mark I TOOL STOP	970637339	290
OHW	970637336	285
OHW-D	970637337	285
PT-1525	970637346	461
RBW-1*	970637334	285
RBW-12916	970637333	285
RBW-12TD	970637332	285
RBW-38H*	970637335	285
RBW-38TD	900050387	285
RBW51638SRP	970368831	285
RBW-58TD	970530305	285
RBW-91634	970426060	285
RBW-RP	970490403	285
RK-1	970084338	461
SC-11	970530302	285
SC-13	970251763	285
TAT/SAT	970341078	290
TK120	970637345	461

STANLEY

SUPPLIER P/N	ALTEC PN	PAGE
00833	36030010	368
00840	900030013	368
00900	36039050	377
01070	970037869	368
02030	36039007	377
02032	36039004	377
02043	36009010	377
02183	705000344	371
05133	705000345	371
05135	893852310	371
06538	812606538	377

STANLEY

SUPPLIER P/N	ALTEC PN	PAGE
07394	970014402	377
10829	36029003	377
17138	36039001	377
21618	36029004	377
32328	885532328	377
33155	36020035	368
33156	36020034	368
34356	900034356	372
60791	900060791	377
BR45110	970649992	370
BR45120E	970361941	370
BR45130E	812645130	370
BR45150	812645150	370
BR45550	812645550	370
BR67120	36060001	370
BR67130	812667130	370
CR27891	36000007	372
CS05610	970079758	372
CS05620	36000020	372
CS06610	812606610	372
CS06620	36000018	372
CS06630	36000019	372
CS25811	893891150	372
CS25812	970084094	372
CS28811	970084092	372
CS28812	970084093	372
CT04016N	809500549	369
CT06026N	900000448	369
CT10016N	900001016	369
CT10056DH	970216377	369
CT10066AN	900000447	369
CT15036GN	970137780	369
DL07550	900020025	368
GD50132RF	900099427	370
GD50133RF	900099428	370
GT13H02	970206056	383
GT18B02	970216392	383
HD01531	970426754	368
ID07810	812604810	368
ID07815	900007815	368
PR41131	36000014	372
PR41231	900041231	372
SM2053101	812620531	371
SM2151101	812621511	371
SM50100	970045814	371
TA54103	36030001	368
TA54603	36030013	368
TA54603A	970017137	368

STIHL USA

SUPPLIER P/N	ALTEC PN	PAGE
3005-3905	970637511	381
3005-3905	970637511	381
3005-3913	970637497	380
3005-4717	970637499	380
3005-4813	970381918	380
4314-007-1001	970637503	380
4314-680-1903	970637504	380
4314-680-1904	970637505	380
4314-680-1905	970637506	380
4314-682-5001	970637507	380
4314-682-5002	970637508	380
4314-682-5003	970637509	380
4314-682-5004	970637510	380
61MM3-44	970637512	381
61MM3-44	970637512	381
61-PMM3	970637498	380
63-PM3-55	970637502	380
BT45	900045000	380
HT100	970052960	381
HT101	970067637	381
MS170	970077802	380
MS211C-BE-16*	970637501	380
MS251	970605592	380
RM3-62	970637500	380



STREAMLIGHT

SUPPLIER P/N	ALTEC P/N	PAGE
44450	970216643	180
44451	970191135	180
44454	970216647	180
44900	970246563	178
44902	970246565	178
44904	970346622	178
44905	970346623	178
44910	970381469	178
44911	970381474	178
44918	970381475	178
44931	970489899	177
45102	900021116	176
45104	900021115	176
45107	900021111	176
45108	900021110	176
45109	900021105	176
45110	900021106	176
45116	900021101	176
45117	900021100	176
45601	970110681	179
45621	970110679	179
45637	970192362	179
45661	970454076	177
45665	970454077	177
45670	970595100	180
45801	970246539	176
45805	970246557	176
45821	970246544	176
45825	970246560	176
45842	970290555	176
45851	970246408	176
45855	970246527	176
45871	970246412	176
45875	970246530	176
45937	900099316	176
61050	900061050	181
61052	900061007	181
61200	970089240	182
61301	900061301	181
66118	970131481	185
66133	970595119	185
68720	970435088	182
68721	970435089	182
68722	970435090	182
71500	900071500	185
71503	900070129	185
74752	970595555	185
75430	970435073	184
75454	970435083	184
75713	970346631	184
75735	970346632	184
85400	970595115	184
88030	970246578	183
88031	970246575	183
88032	970246568	183
88033	970246566	183
88850	970216648	183
88851	970216649	183
88853	970216650	183
88860	970246581	183
88863	970246585	183
90607	970285635	179
90627	970285637	179
90641	970291342	179
90642	970291338	179
90757	970381459	178
90761	970381461	178
90770	970381466	178
45109, 40163	900040163	176
45117, 40163	900040164	176

SVE PRODUCTS

SUPPLIER P/N	ALTEC P/N	PAGE
1818	970444209	142
2424	970444210	142
3232	970444211	142
4545	970444212	142
1616HD	970444208	142
N3272HDS	970444192	142
N3296HDS	970444193	142
N4572HDS	970444194	142
N4596HDS	970444195	142
TM2296-B	970444204	142
TM2296-CG	970444200	142
TM3672-B	970444203	142
TM3672-CG	970444199	142
TM3696-B	970444202	142
TM3696-CG	970444198	142
TM4496-B	970364921	142
TM4496-CG	970444197	142

SVP SYSTEMS GROUP

SUPPLIER P/N	ALTEC P/N	PAGE
10-5000.12	970558879	146
10-7000.12	970398263	146
10-7000BENCH12	970558862	146
10-AEP12	970558870	146
10-AEPTail12	970398260	144
10-AEPTALL12	970398260	146
10-BENCH12	970558865	146
10-CArm-LK	970559122	145
10-CVAN12	970398262	146
10-FUZION12	970398254	145
10-PGE12	970443383	144
10-PGE12	970443383	146
10-SCE12	701209003	144
10-SDGE.12	970320098	146
10-SFile12	970286800	146
10-SW1 NO DRILL VB	970558886	146
10-SW1 NO DRILL W/ RISER	970558884	146
10-TREK12 DRILL MOUNT	970558934	146
10-XTREME12 DRILL MOUNT	970398257	145
4-CArm-Lk	970559122	146
4-CMount-Lk	970559110	146
4-iPad Tray-Lk	970559119	144
4-iPad Tray-Lk	970559119	146
Medium Duty SW1	970558880	146

TANAKA

SUPPLIER P/N	ALTEC P/N	PAGE
TED-270PFL	981752769	381
TED-270PFR	900088874	381

TIGER

SUPPLIER P/N	ALTEC P/N	PAGE
1025A	970034373	112
1025A	970034373	113
1030A	970238600	112
4001D	970074792	367
GRD0010	970354354	366
GRD0015	970354345	366
GRD0020	970354356	366
HA0060	970234213	366
HA0061W	970294923	366
HA0075	970244692	113
HA0080	970354364	113
HB0006 CUBE PUMP	970294936	367
LNG-2012	970412702	112
POLE PULLER PAD	970184541	367

TINGLEY

SUPPLIER P/N	ALTEC P/N	PAGE
1300-2XL	970346590	96
1300-3XL	970346591	96
1300-L	970346588	96

TINGLEY

SUPPLIER P/N	ALTEC P/N	PAGE
1300-M	970346587	96
1300-S	970346586	96
1300-XL	970346589	96
1400-2XL	970346596	96
1400-3XL	970346597	96
1400-L	970346594	96
1400-M	970346593	96
1400-S	970346592	96
1400-XL	970346595	96
31151-10	970346605	96
31151-11	970346606	96
31151-12	970346607	96
31151-13	970346608	96
31151-14	970346609	96
31151-9	970346604	96
31251-10	970346611	96
31251-11	970346612	96
31251-12	970346613	96
31251-13	970346614	96
31251-14	970346615	96
31251-9	970346610	96
35211-2XL	970588700	96
35211-L	970588698	96
35211-M	970588697	96
35211-S	970588696	96
35211-XL	970588699	96
35211-XS	970588695	96
C44122-2XL	970640858	80
C44122-3XL	970640859	80
C44122-4XL	970640860	80
C44122-L	970640856	80
C44122-M	970640855	80
C44122-S	970640854	80
C44122-XL	970640857	80
C53122-2XL	970346500	80
C53122-3XL	970346501	80
C53122-4XL	970346502	80
C53122-L	970346498	80
C53122-M	970346497	80
C53122-S	970346496	80
C53122-XL	970346499	80
C56207-2XL	970588693	81
C56207-3XL	970588694	81
C56207-L	970588691	81
C56207-M	970588690	81
C56207-S	970588689	81
C56207-XL	970588692	81
H56107	970588648	81
J23122-2XL	970346460	81
J23122-3XL	970346461	81
J23122-4XL	970346462	81
J23122-5XL	970346463	81
J23122-L	970346458	81
J23122-M	970346457	81
J23122-S	970346456	81
J23122-XL	970346459	81
J26112-2XL	970588628	77
J26112-3XL	970588629	77
J26112-4XL	970588630	77
J26112-5XL	970588631	77
J26112-L	970588626	77
J26112-M	970588625	77
J26112-S	970588624	77
J26112-XL	970588627	77
J44122-2XL	970640842	80
J44122-3XL	970640843	80
J44122-4XL	970640844	80
J44122-5XL	970640845	80
J44122-L	970640840	80
J44122-M	970640839	80
J44122-S	970640838	80
J44122-XL	970640841	80
J53122-2XL	970346484	80
J53122-3XL	970346485	80
J53122-4XL	970346486	80
J53122-5XL	970346487	80

TINGLEY

SUPPLIER P/N	ALTEC P/N	PAGE
J53122-L	970346482	80
J53122-M	970346481	80
J53122-S	970346480	80
J53122-XL	970346483	80
J53129-2XL	970346507	80
J53129-3XL	970346508	80
J53129-4XL	970346509	80
J53129-5XL	970346510	80
J53129-L	970346505	80
J53129-M	970346504	80
J53129-S	970346503	80
J53129-XL	970346506	80
J56107-2XL	970588659	81
J56107-3XL	970588660	81
J56107-L	970588657	81
J56107-M	970588656	81
J56107-S	970588655	81
J56107-XL	970588658	81
J56207-2XL	970588653	81
J56207-3XL	970588654	81
J56207-L	970588652	81
J56207-M	970588651	81
J56207-S	970588649	81
J56207-XL	970588650	81
O23122-2XL	970346468	81
O23122-3XL	970346469	81
O23122-4XL	970346470	81
O23122-5XL	970346471	81
O23122-L	970346466	81
O23122-M	970346465	81
O23122-S	970346464	81
O23122-XL	970346467	81
O44122-2XL	970640850	80
O44122-3XL	970640851	80
O44122-4XL	970640852	80
O44122-5XL	970640853	80
O44122-L	970640848	80
O44122-M	970640847	80
O44122-S	970640846	80
O44122-XL	970640849	80
O53122-2XL	970346492	80
O53122-3XL	970346493	80
O53122-4XL	970346494	80
O53122-5XL	970346495	80
O53122-L	970346490	80
O53122-M	970346489	80
O53122-S	970346488	80
O53122-XL	970346491	80
O53129-2XL	970346515	80
O53129-3XL	970346516	80
O53129-4XL	970346517	80
O53129-5XL	970346518	80
O53129-L	970346513	80
O53129-M	970346512	80
O53129-S	970346511	80
O53129-XL	970346514	80
O56007-2XL	970588665	81
O56007-3XL	970588666	81
O56007-L	970588663	81
O56007-M	970588662	81
O56007-S	970588661	81
O56007-XL	970588664	81
O56107-2XL	970588871	81
O56107-3XL	970588872	81
O56107-4XL	970588873	81
O56107-5XL	970588874	81
O56107-L	970588869	81
O56107-M	970588868	81
O56107-S	970588867	81
O56107-XL	970588870	81
P23122-2XL	970346476	81
P23122-3XL	970346477	81
P23122-4XL	970346478	81
P23122-5XL	970346479	81

PRODUCT INDEX
BY SUPPLIER ITEM NUMBER

USA: 1-877-GO ALTEC
(1-877-462-5832)

www.alteccconnect.com

TINGLEY

SUPPLIER P/N	ALTEC PN	PAGE
P23122-L	970346474	81
P23122-M	970346473	81
P23122-S	970346472	81
P23122-XL	970346475	81
P56007-2XL	970588679	81
P56007-3XL	970588680	81
P56007-L	970588677	81
P56007-M	970588676	81
P56007-S	970588675	81
P56007-XL	970588678	81
S56307-2XL	970588685	81
S56307-3XL	970588686	81
S56307-4XL	970588687	81
S56307-5XL	970588688	81
S56307-L	970588683	81
S56307-M	970588682	81
S56307-S	970588681	81
S56307-XL	970588684	81
S78122-2XL	970346368	77
S78122-3XL	970346369	77
S78122-4XL	970346370	77
S78122-5XL	970346371	77
S78122-L	970346366	77
S78122-M	970346365	77
S78122-S	970346364	77
S78122-XL	970346367	77
S85522-2XL	970346404	79
S85522-3XL	970346405	79
S85522-4XL	970346406	79
S85522-5XL	970346407	79
S85522-L	970346402	79
S85522-M	970346401	79
S85522-S	970346400	79
S85522-XL	970346403	79
S88122-2XL	970588644	79
S88122-3XL	970588645	79
S88122-4XL	970588646	79
S88122-5XL	970588647	79
S88122-L	970588642	79
S88122-M	970588641	79
S88122-S	970588640	79
S88122-XL	970588643	79
V70632-2X/3X	970346382	77
V70632-4X/5X	970346383	77
V70632-L/XL	970346381	77
V70632-S/M	970346380	77
V70832-2X/5X	970346375	77
V70832-M/XL	970346374	77
V70839-2X/5X	970346373	77
V70839-M/XL	970346372	77
V81622-2X/3X	970588618	79
V81622-4X/5X	970588619	79
V81622-L/XL	970588617	79
V81622-S/M	970588616	79
V81832-2X/3X	970288622	79
V81832-4X/5X	970288623	79
V81832-L/XL	970288621	79
V81832-S/M	970288620	79

TRUCK LITE

SUPPLIER P/N	ALTEC PN	PAGE
8150	970346642	206
8155	970346643	206
8160	970325501	206
8170	970324510	206
40204	701110017	208
81701	970335503	206
81702	970277131	206
81704	970346640	206
81711	970346639	206
81712	970322062	206
81714	970346641	206
10205R	68421016	208

TRUCK LITE

SUPPLIER P/N	ALTEC PN	PAGE
27270C	970346638	206
27450C	970346638	206
30200R	68421034	208

TULSA POWER

SUPPLIER P/N	ALTEC PN	PAGE
RT-10	970056375	151
RT-20	900042000	151
RT-40	900040000	151
RT-60	970056381	151

UTILITY SOLUTIONS

SUPPLIER P/N	ALTEC PN	PAGE
GRAB-IT-1	970127524	457
GRAB-IT-1F	970545584	457
GRAB-IT-2	970284500	457
GRAB-IT-3	970335339	457
USBA-001	970545604	465
USBA-002	970545605	465
USBC-001	970211830	136
USBC-002	970545595	136
USBM-001	970335344	465
USBM-002	970335345	465
USBM-004	970335344	136
USBM-004W	970335345	136
USBS-15-1-PS-S	970113079	451
USBS-15-2-PS-S	970107161	451
USBS-27-1-PS-S	970118311	451
USBS-27-2-PS-S	970211843	451
USBS-46-1-PS-S	970211844	451
USBS-46-2-PS-S	970211848	451
USBS-600-1-S	970363719	451
USCC-001	970545585	457
USCC-002	970545586	457
USCC-003	970545587	457
USCC-004	970335351	457
USCC-005	970335353	457
USCC-006	970335352	457
USCC-007	970335354	457
USCP-001	970107168	465
USCP-002	970208590	465
USCS-001	970361570	491
USEP-15-27	970545596	491
USEP-35	970545597	491
USFS-001	970208576	456
USGT-600	970335361	537
USGT-600-15KV BUSHING	970335363	537
USGT-600-15KV ELBOW	970335362	537
USGT-600-27KV BUSHING	970335365	537
USGT-600-27KV ELBOW	970335364	537
USGT-600-SUB	970335366	537
USJH-001	970208582	458
USJH-002	970548416	465
USJJ-001S	970208572	456
USJJ-002S	970129495	456
USJJ-003S	970545579	456
USJJ-004	970201065	456
USJJ-005	970201067	456
USJJ-006	970545580	456
USJJ-007	970208575	456
USJJ-008	970545581	456
USJJ-009	970545582	456
USJL-001	970208579	459
USJL-002	970208581	459
USJT-001	970545588	458
USJT-002	970545589	458
USLR-XLT-1	970211833	450
USLR-XLT-1-H	970098051	450
USLR-XLT-1-P-H	970545553	450
USLR-XLT-2	900050363	450
USLR-XLT-2-H	970211836	450
USMG-001	970211852	459
USMG-002	970211854	459
USMG-002-BAG	970545594	459
USMG-003	970211858	459

UTILITY SOLUTIONS

SUPPLIER P/N	ALTEC PN	PAGE
USMT-001	970335350	491
USRB-22-28-SLT	970545602	465
USRB-36-28-SLT	970545601	465
USRB-36-6-SLD	970545600	465
USRH-006	970335346	31
USRH-008	970208581	31
USSA-ASD	970335337	455
USSA-HGR	970545570	455
USSA-MSC	970545571	455
USSA-OHP	970545572	455
USSA-ORB	970545573	455
USSA-ORP	970545574	455
USSB-003	970335327	453
USSB-005	970335328	453
USSB-006	970335329	452
USSB-007	970335330	454
USSB-009	970335331	454
USSB-011	970335332	454
USSG-004-EREC	970335300	454
USSG-004-ERSE	970335305	454
USSG-004-IREC	970335309	454
USSG-004-IRSE	970335313	454
USSG-006-EREC	970335302	454
USSG-006-ERSE	970335306	454
USSG-006-IREC	970335310	454
USSG-006-IRSE	970335314	454
USSG-008-EREC	970335303	454
USSG-008-ERSE	970335307	454
USSG-008-IREC	970335311	454
USSG-008-IRSE	970335315	454
USSG-010-EREC	970335304	454
USSG-010-ERSE	970335308	454
USSG-010-IREC	970335312	454
USSG-010-IRSE	970335316	454
USSS-004-SE/EC	970335318	455
USSS-004-SH/EC	970335322	455
USSS-006-SE/EC	970335319	455
USSS-006-SH/EC	970335323	455
USSS-008-SE/EC	970335320	455
USSS-008-SH/EC	970335324	455
USSS-010-SE/EC	970335321	455
USSS-010-SH/EC	970335325	455
USTS-004	970211867	453
USTS-006	970212026	453
USTS-008	970203505	453
USTS-010	970204285	453
USTS-012	970212052	453
USTS-016	970211860	452
USTS-016-EM	970545561	453
USTS-016-MM	970545569	453
USTS-020	970211863	452
USTS-020-EM	970545560	453
USTS-020-MM	970545568	453
USTS-025	970211864	452
USTS-025-EM	970545559	453
USTS-025-MM	970545567	453
USTS-030	970211867	452
USTS-030-EM	970545558	453
USTS-030-MM	970545566	453
USTS-035	970212026	452
USTS-035-EM	970545557	453
USTS-035-MM	970545565	453
USTS-040	970203505	452
USTS-040-EM	970545556	453
USTS-040-MM	970545564	453
USTS-045	970204285	452
USTS-045-EM	970545555	453
USTS-045-MM	970545563	453
USTS-050	970212034	452
USTS-050-EM	970545554	453
USTS-050-MM	970545562	453
USTS-CLEANER	970545575	455
USTS-SILCLOTH	970545576	455
USTS-SILWIPE	970545577	455
USTS-WAX	970545578	455
USUW-001	970287632	491

UTILITY SOLUTIONS

SUPPLIER P/N	ALTEC PN	PAGE
USVS-001	970238385	458
USVS-002	970545591	458
USVS-003	970545592	458
USVS-004	970545593	458
XFMR-3BUSHING	970335355	537
XFMR-3BUSHING-PRL	970335359	537
XFMR-4BUSHING	970335356	537
XFMR-4BUSHING-PRL	970335360	537
XFMR-LEADS	970335358	537
XFMR-PRM	970335357	537

VANAIR

SUPPLIER P/N	ALTEC PN	PAGE
50018	970637392	393
50136	970637403	394
50139	970637402	394
50213	970637391	392
50216	970637404	394
50239	970637389	392
50518	970400061	393
50590	970308038	393
50680	970400060	393
50711	970637395	394
50712	970637396	394
50713	970637397	394
50735	970637393	393
50761	970637398	394
50764	970637399	394
50780	970637400	394
50782	970637401	394
50790	970637394	393
50844	970637388	392
50846	970637406	394
50848	970637405	394
51167	970637390	392
51259	970637387	391
DP90150	MODEL #	390
DP90150	MODEL #	390
DP90150	MODEL #	391
DV90066	MODEL #	390
DV90066	MODEL #	391
DV90096	MODEL #	390
DV90096	MODEL #	391
G66185	MODEL #	390
G96185	MODEL #	390
GF66185	MODEL #	390
TD904X4	MODEL #	390
TD904X4	MODEL #	391
TD904X4	MODEL #	391
U90085	MODEL #	390
U90185	MODEL #	390
U90200	MODEL #	390
UF90100	MODEL #	390
UF90185	MODEL #	390
UH90085	MODEL #	390
UH90185	MODEL #	390
UH90200	MODEL #	390
V366185	MODEL #	391
V396185	MODEL #	391
V3F66185	MODEL #	391
V3F96185	MODEL #	391
USJL-001	970208579	459
USJL-002	970208581	459
USJT-001	970545588	458
USJT-002	970545589	458
USLR-XLT-1	970211833	450
USLR-XLT-1-H	970098051	450
USLR-XLT-1-P-H	970545553	450
USLR-XLT-2	900050363	450
USLR-XLT-2-H	970211836	450
USMG-001	970211852	459
USMG-002	970211854	459
USMG-002-BAG	970545594	459

WEST COAST SHOE COMPANY

SUPPLIER P/N	ALTEC PN	PAGE
110100-10.5D	970406017	95
110100-10.5E	970406027	95
110100-10.5EE	970406037	95
110100-10D	970406016	95
110100-10E	970406026	95
110100-10EE	970406036	95
110100-11.5D	970406019	95
110100-11.5E	970406029	95
110100-11.5EE	970406039	95
110100-11D	970406018	95
110100-11E	970406028	95
110100-11EE	970406038	95
110100-12D	970406020	95
110100-12E	970406030	95
110100-12EE	970406040	95
110100-13D	970406021	95
110100-13E	970406031	95
110100-13EE	970406041	95
110100-8.5D	970406013	95
110100-8.5E	970406023	95
110100-8.5EE	970406033	95
110100-8D	970406012	95
110100-8E	970406022	95
110100-8EE	970406032	95
110100-9.5D	970406015	95
110100-9.5E	970406025	95
110100-9.5EE	970406035	95
110100-9D	970406014	95
110100-9E	970406024	95
110100-9EE	970406034	95
7700100-10.5D	970405997	95
7700100-10.5E	970406007	95
7700100-10D	970405996	95
7700100-10E	970406006	95
7700100-10.5D	970405999	95
7700100-11.5E	970406009	95
7700100-11D	970405998	95
7700100-11E	970406008	95
7700100-12D	970406000	95
7700100-12E	970406010	95
7700100-13D	970406001	95
7700100-13E	970406011	95
7700100-8.5D	970405993	95
7700100-8.5E	970406003	95
7700100-8D	970405992	95
7700100-8E	970406002	95
7700100-9.5D	970405995	95
7700100-9.5E	970406005	95
7700100-9D	970405994	95
7700100-9E	970406004	95
9710-10.5D	970405914	93
9710-10.5E	970405922	93
9710100-10.5D	970405931	93
9710100-10.5E	970405941	93
9710100-10.5EE	970405951	93
9710100-10D	970405930	93
9710100-10E	970405940	93
9710100-10EE	970405950	93
9710100-11.5D	970405933	93
9710100-11.5E	970405943	93
9710100-11.5EE	970405953	93
9710100-11D	970405932	93
9710100-11E	970405942	93
9710100-11EE	970405952	93
9710100-12D	970405934	93
9710100-12E	970405944	93
9710100-12EE	970405954	93
9710100-13D	970405935	93
9710100-13E	970405945	93
9710100-13EE	970405955	93
9710100-8.5D	970405927	93
9710100-8.5E	970405937	93
9710100-8.5EE	970405947	93

WEST COAST SHOE COMPANY

SUPPLIER P/N	ALTEC PN	PAGE
9710100-8D	970405926	93
9710100-8E	970405936	93
9710100-8EE	970405946	93
9710100-9.5D	970405929	93
9710100-9.5E	970405939	93
9710100-9.5EE	970405949	93
9710100-9D	970405928	93
9710100-9E	970405938	93
9710100-9EE	970405948	93
9710-10D	970405913	93
9710-10E	970405921	93
9710-11.5D	970405916	93
9710-11.5E	970405924	93
9710-11D	970405915	93
9710-11E	970405923	93
9710-12D	970405917	93
9710-13D	970405918	93
9710-13E	970405925	93
9710-8.5D	970405910	93
9710-8.5E	970405909	93
9710-8E	970405919	93
9710-9.5D	970405912	93
9710-9.5E	970405911	93
9710-9E	970405920	93
9716-10.5D	970405961	94
9716-10.5E	970405971	94
9716100-11.5D	970405979	94
9716100-11.5E	970405988	94
9716100-11D	970405978	94
9716100-11E	970405987	94
9716100-12D	970405980	94
9716100-12E	970405989	94
9716100-13D	970405981	94
9716100-13E	970405990	94
9716100-8.5D	970405976	94
9716100-8.5E	970405983	94
9716100-8E	970405982	94
9716100-9.5E	970405985	94
9716100-9D	970405977	94
9716100-9E	970405984	94
9716-10D	970405960	94
9716-10E	970405970	94
9716-11.5D	970405963	94
9716-11.5E	970405973	94
9716-11D	970405962	94
9716-11E	970405972	94
9716-12D	970405964	94
9716-12E	970405974	94
9716-13D	970405965	94
9716-13E	970405975	94
9716-8.5D	970405957	94
9716-8.5E	970405967	94
9716-8D	970405956	94
9716-8E	970405966	94
9716-9.5D	970405959	94
9716-9.5E	970405969	94
9716-9D	970193904	94
9716-9E	970405968	94
CST5710-10.5D	970405874	92
CST5710-10.5E	970405884	92
CST5710-10D	970405873	92
CST5710-10E	970405883	92
CST5710-11.5D	970405876	92
CST5710-11.5E	970405886	92
CST5710-11D	970405875	92
CST5710-11E	970405885	92
CST5710-12D	970405877	92
CST5710-12E	970405887	92
CST5710-13D	970405878	92
CST5710-13E	970405888	92
CST5710-8.5D	970405870	92
CST5710-8.5E	970405880	92

WEST COAST SHOE COMPANY

SUPPLIER P/N	ALTEC PN	PAGE
CST5710-8D	970405869	92
CST5710-8E	970405879	92
CST5710-9.5D	970405872	92
CST5710-9.5E	970405882	92
CST5710-9D	970405871	92
CST5710-9E	970405881	92
ST5710100-10.5D	970405894	92
ST5710100-10.5E	970405904	92
ST5710100-10D	970405893	92
ST5710100-10E	970405903	92
ST5710100-11.5D	970405896	92
ST5710100-11.5E	970405906	92
ST5710100-11D	970405895	92
ST5710100-11E	970405905	92
ST5710100-12D	970405897	92
ST5710100-12E	970405907	92
ST5710100-13D	970405898	92
ST5710100-13E	970405908	92
ST5710100-8.5D	970405890	92
ST5710100-8.5E	970405900	92
ST5710100-8D	970405889	92
ST5710100-8E	970405899	92
ST5710100-9.5D	970405892	92
ST5710100-9.5E	970405902	92
ST5710100-9D	970405891	92
ST5710100-9E	970405901	92

WHELEN

SUPPLIER P/N	ALTEC PN	PAGE
2FA00ZAR with 2GROMMET	970570192	190
50A02ZAR w/5GROMMET	970570292	190
6RBA w/6FLANGEB	970570190	190
6RBA with 6FLANGEB	970570190	190
IONSVA	970570186	190
L21HAP	970570180	190
L31HAF w/ L360BGB	970102931	190
MC16PA	970411115	190
MPBB	970361864	191
NP3BB	970570283	191
NP6BB	970570285	191
P46HHS	970570287	191
PCPSM1C	970570202	191
PCPSM2C	970570208	191
PFBP12	970291056	191
PSC0CDCR	970109584	191
PT360F	970389362	190
PT360FW	970389446	191
R2LPPA	970162775	190
V23ATPB	970508851	190
V23ATPB	970508851	190
VTX609A with VTXFB	970570197	190

WISS/APEX

SUPPLIER P/N	ALTEC PN	PAGE
0890CSFW	970637621	271
WKF1	970641341	275

WOLF PEAK EDGE SAFETY EYEWEAR

SUPPLIER P/N	ALTEC PN	PAGE
XB116-A1	970567788	35
XB116-A2	970567791	35
XB116-C1	970567793	35
XB116-P1	970567797	35

WOLF PEAK EDGE SAFETY EYEWEAR

SUPPLIER P/N	ALTEC PN	PAGE
XB116-V1	970567798	35
XB146-C2	970567814	35
XB146-P2	970567818	35
XB146-V2	970567809	35

WOOD OWL

SUPPLIER P/N	ALTEC PN	PAGE
1004	970136918	374
1006	970136919	374
1008	970136920	374
1010	970136921	374
1012	970136922	374
1013	970136923	374
1014	970180636	374
1015	970136925	374
1017	970136927	374
1018	970136928	374
1019	970136929	374
8806	970272444	374
8808	970246427	374
8810	970221868	374
8812	970231115	374
8813	970136911	374
8814	970136912	374
8815	970136913	374
8817	970136914	374
8818	970136915	374
8819	970136916	374

WRIGHT TOOL

SUPPLIER P/N	ALTEC PN	PAGE
4422	970186452	373
4772	970186586	373
4774	970186587	373
4776	970186588	373
4778	970186589	373
4780	970186590	373
4782	970186591	373
4784	970186592	373
4786	970186594	373
4788	970186596	373
4790	970186598	373
4792	970186599	373
4794	970186600	373
4796	970186601	373
9076	970186453	373

ZOLL

SUPPLIER P/N	ALTEC PN	PAGE
8000-004000-01	970640270	30
8000-004003-01	970640771	30
8000-004004-01	970640772	30
8000-004007-01	970530060	30
8000-004010-01	970640773	30
8000-004011-01	970640774	30
8900-0800-01	970640775	30
8900-0810-01	970640776	30
8000-0807-01	970640777	30
8000-0855	970464025	30
8000-0825	970640778	30
8000-0836-01	970620671	30
8000-0837-01	970464021	30

PRODUCT INDEX
BY SUPPLIER ITEM NUMBER

USA: 1-877-GO ALTEC
(1-877-462-5832)

www.alteconnect.com

ALPHABETICAL KEYWORD PRODUCT INDEX

**PRODUCT INDEX
ALPHABETICAL KEYWORD**

**USA: 1-877-GO ALTEC
(1-877-462-5832)**

www.alteconnect.com

Altec P/N	PAGE
Absorbent - For Spills	118
ACSR Cutters	296-297, 314-315
Adapter	349-350, 371, 375, 522, 523
Adapter, Augers	523
Adapter, Blue Bully	365
Adapter, Bolt Circle	417
Adapter, Chuck	373
Adapter, Jib Brace	447
Adapter, Kelly Bar	416
Adapter, Knockout Punch	313
Adapter, Rope	495
Adapter, Round	412
Adapter, Shotgun Universal Tool	449
Adapter, Snap-On	445
Adapter, Socket	267
Adapter, Tool	373
Adjustable Strain Pole	433
Adjuster Socket	440
Aed Plus	30
Aerial Aprons	121
Aerial Belt	563
Aerial Hooks	125
Air Compressor Packages	394
Air N Arc Systems	393
Alarms, Back-Up	169, 189
All Purpose Cleaner	446
Alloy Shackles	250
Alloy Shackles	252
Alternator	371
Ammeter, Digital	548
Amptact Tools	306
Anchor Auger	529
Anchor Hook	234
Anchor Installing Tool Pin	417
Anchor Plate, Light Pole	417
Anchor Shackle	252
Anchor Tools	418
Anchor Wrench	416
Angle Grinder	337, 385, 388
Ankle Straps	59
Ankle Straps, Tree Climbers	558
Anti-Skid Material	165
Anti-Skid Surfacing Material	23
Apron, Aerial	121
Apron, Tool	131
Arborist Ropes	564-566, 568-569
Arbormaster Rope	564
Arbor-Plex Rope	564
Arc Snuffer Removal Tools	431
Acrlite Outerwear	82
Argo Headlamp	181
Arm Assembly	448
Arm Attachment	414
Arm Attachment, Jib Mounted	447
Arm, Barricade	24
Ascr Cutters	307
Assembly, Hose (Sievert)	384
Auger Bits	350, 363
Auger Bits, Ship	332
Auger Heads, Dirt	516
Auger Heads, Rock Ropper	516
Auger Heads, Step Rock	516
Auger Tarp	246, 527
Auger, Anchor	529
Auger, Planting	380
Augers, 9000 Series	529
Augers, Duplex Boom Type	528
Augers, Pressure Digger	519, 520
Augers, Quick Change	515
Augers, Rock Ripper	514
Augers, Standard	528
Augers, Trimax	518
Augers, Utility	510-526
Auxiliary Arm Rubber Glove	449
Auxiliary Lamp	206
Av Meter	551
Awl, Scratch	260

Altec P/N	PAGE
Backpack, Lineman's	559
Back-Up Alarms	169, 189
Back-Up Camera	147
Bag (Storage) Grounding Assemblies	402, 411
Bag, Nut & Bolt	118
Bag, Pole Storage	570
Bag, Rope Storage	570
Bag, Sleeve	474
Bag, Vinyl Equipment	559
Bags For Gloves	103
Bags For Sleeves	103
Bags, Gloves	474-475,
Bags, Sleeve	480
Bags, Tool	57, 118
Balaclava	70
Ball Bearing Swivels	497
Ball Pein Hammer	557
Ball Socket Ground Clamps	406
Ball Studs	401, 406
Ball Swivel	160
Band Saw	327-328, 388
Band Saw Kit	337
Band Saw, Cordless	322
Bar, Barricade	24
Bar, Chainsaw	336
Bare Wire Grips	211
Barricade Arm	24, 162
Barricade Kit	24, 162, 163, 446, 447
Barricade Kit For Altec Units	163
Barrier, Overhead Switch	467
Bars, Pry	274
Base Pole	576
Bashlin Lineman's Wear	72-76
Battery Powered Flashlight	207
Battery, Burndy	320
Battery, Greenlee	308, 313
Battery, Milwaukee	332
Beacon	190, 197, 208
Beanie	70
Belt, Aerial	563
Belt, Lineman	43, 48, 49
Bib Overalls	67
Big Buck Wrap Pad	51
Big Kahuna Cutters	307
Bit Set, Shockwave	333
Bits, Auger	350, 363
Bits, Black Widow	341
Bits, Impact	350
Bits, Nail Eater Extreme	350
Bits, Nail Eater li	350
Blade	332
Blade, Sawzall	333
Blades, Saw	570
Blades, Threaded Rod Cutting	313
Blanket Clamp	257, 464
Blanket Holder	465
Blanket Mate	465
Blanket Pins	471
Blankets, Insulated	466
Blankets, Rubber	465
B-Lite Poles	576
Block & Tackle	235
Block, Cable	508
Block, Guide	505
Block, Handline	253, 254
Block, In Line	506
Block, Nylon	253
Block, Nylon Rope	254
Block, Pole Top	255
Block, Snatch	253-254, 534
Block, Starting	506
Block, Stringing	255
Blocks	235, 253
Blower, Fiber Optic	501
Blue Bully Adapter	365
Blue Stripe Hot Sticks	455
Blue Stripe Rescue Hook	31
Blue Stripe® Shotgun Sticks	454

Altec P/N	PAGE
Blue Stripe® Telescopic Hot Sticks	452, 453
Blue-Stripe Cleaner	455
Boards, Tool Organizing	130
Body Belt	48-49
Bolt Cutters	301, 304- 306
Bolt-Thru Strobes	203
Boom Handle System	39
Boom Mount Tool Holders	133
Boom Wax, Hot Stick	446
Boots	86-96
Box Wrench Set	266
Brace Clamps	448
Brace Pole	448
Bracket, Rope Snubbing	422
Breakers, Paving	356
Break-Safe® Load Break & Pick-Up Tool	451
Brown Duck Dungaree	66
Brown Duck Jacket	66
Brushblade Linemans Knife	463
Bttv Travelers	255
Buck Combo Yard	56
Buck Ladder Lock System	54
Buck Limiter	56
Buck Linebacker	49
Buck Mobility Belt	48
Buck Self Rescue System	563
Buckadjuster	47
Bucket, Tool	121-124
Buckit Restraint System	55
Buddy System	168
Bugwrench	284
Bull Rope	568
Bullet Shank	521
Bumper, Rubber	169
Buried Line Locator	541
Bushing Installation Tools	461
Bushing Kits	288
Bushing, Loadbreak	537
Button Down Shirt	63
Buttons, Sleeve	474, 480
C Bracket	223
Cable	248
Cable & Pipe Locators	489
Cable Bending Tool	498
Cable Block	509
Cable Crimper	306
Cable Cutters	293-297, 301, 303- 304, 307, 314-316, 321-322
Cable Cutting Blades	313
Cable Feeder Nozzles	499
Cable Feeders	499
Cable Feeding Guide	492
Cable Guide	492, 505, 509
Cable Hoist	219, 230
Cable Identifier	548
Cable Length Meters	541
Cable Puller	482, 484
Cable Puller	484, 501
Cable Pulling Grips	487
Cable Reel Jacks	504
Cable Steps	167
Cable Stripper	288
Cable Stripper, Adjustable	292
Cable, Grounding	396
Cage Ladders	115
Cage Organizer	366
Camera, Back-Up	147
Canister, Hot Stick	445
Cant Hook	110, 116
Cant Hooks	572
Canvas Bag	57
Cap, Rubber	170
Capacitor Tester	552
Capstan	503
Capstan Brackets	223
Capstan Drive	503
Capstan Gas Hoist	222
Capstan Heads	166
Capstan, Fiber Optic	501

Altec P/N	PAGE
Carabiner	53
Carbon Shackles	250, 252
Cargo Net	164
Cargo Pants	65
Carnuba Wax	455
Cats Eye, Link	151
Chain Hoist	218
Chain Saw	336, 358, 359, 372, 380
Chain Saw Holder	128
Chain Saw Lanyard	569
Chain Saw Scabbard	128
Chain Slings	248
Chain, Chainsaw	336
Chain, Construction	496
Chargers, Burndy	320
Chargers, Greenlee	308, 313
Chargers, Milwaukee	332
Chest For Tools	122
Chicago Grips	211, 214
Chisel	274
Choker, Steel	248
Chuck Adapter	373
Chuck, 3 Jaw	333
Chuck, Keyed	341
Chuck, Quick Change	365
Chuck, Quick Release	375
Circuit Tracer	543
Circular Saw	358, 372
Circular Saw Holder	128, 573
Circular Saw Kit	326
Clamp Assembly, Brass Arm	412
Clamp Meter	538, 549
Clamp Meters	540
Clamp Stick Head	449
Clamp, Blanket	464
Clamp, Jumper	397
Clamp, Substation	537
Clamp, Tie Back	435
Clamps, Ground	395
Clamps, Grounding (Apparatus)	401
Clamps, Grounding (Ball Stud)	400
Clamps, Grounding (C-Type)	398-399
Clamps, Grounding (Flat Face)	400
Clamps, Jumper	409
Clamps, Klondike	465
Clampsticks	423
Claw Climbers	58
Cleaner, All-Purpose	446
Cleaning Brush, Conductor	436, 449
Cleaning/Refinishing Kit	446
Clean-N-Glaze	165
Clevis Pin Holder	438
Climber Pads	51, 58, 561
Climber Straps	37, 59
Climber System	58
Climbers, Aluminum, Titanium, Steel, Alloy	50
Climbers, Claw	58
Climbers, Pole	37
Climbers, Tree	37, 58, 558
Climbing Ropes	569
Clothing	60-85
Cluster Grounds	402
Comfort-Brite Outerwear	80
Commander Series	189
Compressor Systems	390
Conductor Cleaning	457
Conductor Cleaning Brush	440, 449
Conductor Covers	467-468
Conductor Grips	212
Conductor Holder	447, 448
Conductor Support Equipment	420
Conductor Supports	419, 422
Conduit Brushes	493
Conduit Cleaners	493
Conduit Missile Line Carriers	496
Conduit Pistons	486
Conduit Riser Grips	240
Conduit Rodders	488-489
Conduit Seal-Off	496
Cone Lights	202
Cones, Safety	164, 574
Connecting Links	498
Connector Wrenches	279-281
Connector, Rope To Rope	505, 507

Altec P/N	PAGE
Connectors, Rope To Swivel	505
Control Valve	495
Controller, Pilot Line	256
Controller, Stringing	255
Convertible Web Strap Pullers	228
Cooler Truck Racks	169
Coolers	139
Coolers, Pro-Gear Elite	138
Cooling Bandana	27
Cooling Vest	27
Cord Caddies	155
Cordless Ratchet Kit	322
Corner Led Systems	189
Corner Restraint Bracket Tool	421
Couplings	357, 360, 374-375, 522
Cover Hook, Manhole	493
Cover Lifter, Manhole	493
Cover, Conductor	467
Cover, Crossarm	467
Cover, Pruner	571
Covers, Conductor	468
Covers, Insulator	467
Covers, Platform	135
Covers, Pole	467
Cowboy Hard Hat	26
Crimper, 60 Ton	350
Crimper, Cable	306
Crimping Dies	376
Crimping Heads, Remote	350
Crimping Tool	320
Crimping Tool Holder	129, 131
Crimping Tools	298, 302- 303
Crimping Tools, Battery Powered	309-312, 321
Crimping Tools, Hydraulic	352-353, 364
Crimping/Stripping Tools	287
Crossarm Cover	467
Crossarm Gin	423
Crossarm Link Stick	433
Crossarm Tool Hanger	436
Crow Bar	109
Curved Jaw Grips	211
Cutout Bypass Tool	456
Cutout Tool, Universal	440
Cutter Dies	308
Cutter, Cable	301, 303- 304, 314
Cutters Selection Guide	299
Cutters, ACSR	296-297, 307, 314- 315
Cutters, Battery Powered	321-322
Cutters, Bolt	301, 304- 306
Cutters, Cable	293-296, 307, 315- 316
Cutters, Flip Joint	271
Cutters, Gator	315-316
Cutters, Guy Strand	304-305
Cutters, Hydraulic Manual	306
Cutters, Long Nose	263
Cutters, One Time Lock	315
Cutters, Ratchet	305
Cutters, Side	264
Cutters, Wire	296
Cutting Tools, Hydraulic	352-353
Cylinder Lock	171
Cynch-Lok	45
Dark Horse Ladders	115
Decklight	210
Deep Tool Tray	126
De-Icer	165
Delta Harness	41
Demolition Driver	262
Denim Jean / Dungaree	64-65
Denim Jean, Women's	71
Desks, Mobile	144-150
Desks, Pedestal	144-150
Detectable Rodders	489
Detector, Neutral	552
Deviner	462
Diagonal Pliers	277
Die Adapters	313

Altec P/N	PAGE
Die Cast Toy Truck	14-15
Die Kit	320
Die Storage	320
Die Storage	376
Dieless Crimping Tool	311
Dies, Compression	342-347
Dies, Crimping	376
Dies, Cutter	308
Dies, Installation	320
Digging Bars	109
Digging Spud	109
Digital Ammeter	548
Digital Phasing Tester	545
Dirtball	246, 527
Disconnect Head	449
Disconnect Hot Sticks	445
Disconnect Sticks	444
Disconnect Tool	421
Disconnects	427-429
Distribution Tool Kit	291
Dollies	113
Dolly	112
Dominator Auger Bits	363
Door Handle	171
Double End Wrench	282
Double Tool Tray	126
Double-Header	462
Dri-Lex Body Belt	48
Dri-Line Boots	86
Drill Bit Set	333
Drill Bits	341
Drill Bits, Impact	374
Drill, Gas Engine	381
Drill, Hammer	368
Drill, Impact	348
Drilling Hammer	557
Driver Kit	323
Driver, Ground Rod	355, 366
Driver, Impact	324
Driver, Penta Socket	462
Driver, Sign Post	354
Driver-Drill Kit	336
Drivers, Klein	262
Dual Conductor Grip	214
Dual Ratchethoist	219
Duct Hunter Rodders	489
Duct Projectiles	496
Duct Rod Pusher	494
Duct Rodders	495
Duct Seal Putty	106
Duct Swabs	494
Dungarees, Brown Duck	66
Dungarees, Denim	64
Duplex Augers	528
Durascrim Outerwear	81
Dust Cap & Plugs	375
Dynaflex Sign Stand	21
Dynamometer	536
Eclipse FR Outerwear	80
Ecoabsorb	118, 165
EH Lineman Pac Boots	91
EK425 Jaws & Cases	309
EK425 Tools	308
Elbow And Cap Pulling Tool	461
Elbow Connector Tool Grippers	432
Elbow Mule	491
Elbow Puller	432
Elbow, Loadbreak	537
Electrical Tester	541
Electrically Driven Hoists	221
Eliminator Auger Bits	363
Emergency Warning Kit	22
End Stripper	292
Epoxiglas Cleaning Kit	434
Epoxirod, Solid	412
Epoxy Insulator	422
Equi-Mat Ground Grid	403
Equipment Bag	118-119, 570
Ergo-Blade Knife	57
Evacuator Plus	189
Evolution Hard Hats	25
Exofit Harness	42
Extender Chain	422
Extendo Kit	446
Extension	413

Altec P/N	PAGE
Extension Arm	419
Extension Arm Retrofit	420
Extension Ladders	117
Extension Resistor	544
Extension Rule	267
Extension Shafts	522
Extension Sticks	430
Extensions	522
Extinguisher, Fire	31
Fairleads	169
Fender, Rubber	170
Ferrules, Grounding	397, 407
Ferrules, Jumper Cable	409
Fiber Optic Blower	501
Fiber Optic Cable Deployments	502
Fiber Optic Capstan	501
Fiber Optic Pulling Trailer	501
Fiberglass Step	122
File Set	274
Filter, Hydraulic Return	165
Fire Extinguisher	31
Fire Vulcan	180
Firebolt Led	188
First Aid Kit	31
Fish Tapes	488
Fishing System	487
Flame Burner	384
Flashlights	183-185, 207
Flashlights, Polytac	183
Flashlights, Protac	183
Flatround Wire Brush	463
Flatround™	463
Fliplines, Arborist	567-568
Flood Light	191, 205, 210
Flow Control Valve	361
Foam Filled Straight Sticks	455
Foam For Pole Setting	106
Folding Flag System	20
Folding Rule	267
Force2	44
Fork Meter	538
Fork Tool, Universal	435
Foxfire Logger Lite	22
FR Shirt	67
Full Float Body Belt	48-49
Fuse Handling Fitting	464
Fuse Puller Tool	438
Fuse-Cup	449
Fuse-Safe Tool	456
G Cable Block	508
G Cable Lasher	508
G Model Chain Hoist	218
Gaff Guards	37, 51, 59, 558
Gaff Sharpening Kit	558
Gas Hoist, Capstan	222
Gas Lamp Tester	541
Gator Crimping Tools	310
Gator Cutters	315-316
Gauges, Test	364
Gear Bag	561
Gear Bucket Haul Bag	57
Gear Shield	165
Generator	382-383
Gins	423
Glasses, Safety	32-35
Glove Bags	103
Glove Bags	103, 474-475, 480
Glove Covers	475
Gloves	98, 100-103
Gloves, Rubber Insulating	475-477
Gloves, Work	559
Golight/Radioray	198-199
Grab-It Cutout Fuse Tube Remover	457
Grinder	326, 328
Grinder, Angle	337, 388
Grip Clevis	492
Grip, Dual Conductor Chicago	214
Grip-All Hot Sticks	426

Altec P/N	PAGE
Grips	211-213, 216-218, 240-241, 245, 487
Grips Chart	216-217
Grips, Bare Wire	211
Grips, Cable Pulling	487
Grips, Chicago	211
Grips, Conductor Grips	212
Grips, Conduit Riser	240
Grips, Curved Jaw	211
Grips, Hot Line	218
Grips, JI-R Series	242
Grips, Klein Haven	212
Grips, Oh	242
Grips, Ouchless	245
Grips, Parallel Jaw	213
Grips, Pulling	237-238
Grips, Spring-Loaded	218
Grips, U-Bail	239
Grips, Weatherproof Wire Grips	212
Grips, Wire Pulling	213
Ground Cable Splice	408
Ground Protection Mat	141
Ground Resistance Tester	540
Ground Rod Driver	116, 355, 366, 411
Ground Rod Driver Attachment	332
Grounding Assemblies	395
Grounding Cable	396
Grounding Clamps	395, 398-401, 404-406, 408
Grounding Clamps (Apparatus)	401
Grounding Clamps (Ball Stud)	400
Grounding Clamps (C-Type)	398-399
Grounding Clamps (Duck Bill)	404
Grounding Clamps (Flat Face)	400, 405
Grounding Clamps (Substation)	405
Grounding Clamps (Tower)	405
Grounding Clamps, Ball Stud	395
Grounding Clamps, C-Head	404
Grounding Cluster Bars	408
Grounding Cluster Supports	408
Grounding Ferrules	397, 407
Grounding Reels	410
Grounding Saddle	411
Grounding Set, Truck	403
Grounding Stud Covers	402
Grounding Tester	545
Grounds Storage	411
Grounds, Cluster	402
Guard Rail, Manhole	493
Guards, Axe	562
Guide Block	505
Gut Straps	49
Guy Strand Cutters	304-305
Gxl	198-199
Hacksaw	259, 269, 275-276
Hammer	435, 269, 274, 269, 278, 385, 557
Hammer Drill	322-323, 327-328, 336, 368
Hammer Tool	435
Hammer, Ball Peen	269
Hammer, Claw	274
Hammer, Curved Claw	269
Hammer, Milled Face	269
Hammer, Rotary Electric	385
Hammer, Sledge	274
Hammer, Stiletto	278
Hammer, Straight Claw	269
Hand Cleaner	105
Hand Guards	438
Hand Sanitizer	105
Hand Warming Packs	102
Handle Holder, Replacement	573
Handle, Door	171
Handline Block	253-254
Handline Carrier	48
Handlines, Underground	497
Handlines, Utility	497

Altec P/N	PAGE
Hard Hat Inserts	27
Hard Hat Sweatband	27
Hard Hats	25, 26, 97
Harness	39, 41-43, 56, 480, 562
Harness, Cable Bending	498
Harness, FR	41-43
Hatchets	557
Haul Bag	57
Headlamps	181, 206
Henley Shirts	59-62, 75
Hex Hubs	522
Hex Keys	260, 272
Hex Socket Sets	430
Hexagonal Wrenches	283
High Visibility Rainwear	80-83
High Visibility Wear	77-85
Highlighter Led	187
Hinges	170
Hitch-Receiver Mount	224
Hi-Visibility Shirt	67
Hoist Comparison Chart	232
Hoist, Cable	219, 230
Hoist, Chain	218
Hoist, Convertible	227
Hoist, Dual Ratchet	219
Hoist, Electrically Driven	221
Hoist, G Model	218
Hoist, Hydraulically Driven	222
Hoist, LB Lever	225
Hoist, Lineman's	227
Hoist, Lineman's Ratchet Lever	230
Hoist, Linemans Strap	220
Hoist, LSB	218
Hoist, Mechanical	221
Hoist, Mini	218
Hoist, Nylon Strap	221
Hoist, Puller	225
Hoist, Ratchet Lever	230
Hoist, Ratchet Lever	219
Hoist, Strap	219, 231
Hoist, Web Strap	215, 226
Hoist, Web Strap Pullers	228-229
Holder, Chain Saw	132
Holder, Conductor	448
Holder, Crimping Tool	129, 131
Holder, Drill Bit	341
Holder, Hotstick	128
Holder, Hydraulic	573
Holder, Impact Tool	128
Holder, Impact Tool	132
Holder, Knife	268
Holder, Litebox	129
Holder, Litebox	176
Holder, Outrigger Pad	167
Holder, Pruner	128
Holder, Safety Cone	167
Holder, Wheel Chock	167
Hole Cutter	307
Hole Saw Kit	333
Hollow Core Auger Bits	363
Holster	57
Holster, Wrench	283
Hook Plunger	234
Hook, Adjustable	440
Hook, Manhole Cover	492
Hook, Snap	234
Hook, Swivel	535
Hook, Swivel Anchor	234
Hooks, Platform Bucket	125
Hose Assemblies For Gator Cutter	316
Hose Assembly	350, 374, 384
Hose Ducting	490
Hose Stands	492
Hose, Connector End	468
Hose, Non-Conductive	361
Hose, Straight Line	468
Hoses, Tools	357, 364, 376
Hot Line Accessories	436
Hot Rodder Tool	438
Hot Stick	424
Hot Stick Accessories	455
Hot Stick Barrier	424-425
Hot Stick Boom Wax	446
Hot Stick Canister	445

Altec P/N	PAGE
Hot Stick Cloth, Silicone	455
Hot Stick Hanging Rail	129
Hot Stick Holder	128, 573
Hot Stick Tester	545
Hot Stick Wipes	446, 455
Hot Stick, Telescopic	453
Hot Sticks	427
Hot Sticks, Disconnect	444-445
Hot Sticks, Foam Filled	455
Hot Sticks, Grip-All	426
Hot Sticks, Shotgun	454
Hot Sticks, Spliced Switch	444-445
Hot Sticks, Substation	444
Hot Sticks, Switch	445
Hot Sticks, Tel-O-Pole	443
Hubs	522
Hydra-Cool Climber System	58
Hydraulic Crimpers, Manual	298-302
Hydraulic Crimping/Cutting Tools	352-353
Hydraulic Cutters, Manual	306
Hydraulic Fluid	316, 364
Hydraulic Paving Breakers	356
Hydraulic Pole Puller	355, 367, 372, 374
Hydraulic Power Unit	360, 391
Hydraulic Pump	367
Hydraulic Return Filter	165
Hydraulic Tool Assemblies	377-379
Hydraulic Tools	348
Hydraulically Driven Hoist	222
Hypress Crimping Tool	302, 364
Hypress Hydraulic Crimper	302
Hytool	303
Ice Wacker	455
Impact Drill	348
Impact Drill Bits	350, 374
Impact Driver	324
Impact Driver Set	335
Impact Sockets	373
Impact Tool Holder	128, 133 323-325, 327, 334- 335, 340, 348, 368, 385
Impact Wrench	385
Impact Wrench (Electric)	385
Impact Wrench, Pneumatic	389
Impacting Drill	323
Impaxx	188
In Line Block	506
Industrial Cable Hoist	230
Innerduct Seal-Off	496
Insect Repellent	105
Insulated Link Stick	433, 442
Insulated Ratchet Cutters	443
Insulated Tool Kit	257
Insulated Tools	263
Insulated Wrenches	430
Insulating Hood	471
Insulator Covers	467
Intensifier, Dynapress	361
Interface Kit	542-543
Inverters	143
IQ Polo, Men's	59
IQ Polo, Women's	71
IQ T-Henley	59
IQ T-Shirt	59
Jack Jumper	456
Jacket	69-70
Jacket, Brown Duck	66
Jacket, High Visibility	85
Jacket, Hi-Vis	77
Jacks, Reel	504
Jamb Skid	500
Jaw Covers	309
Jaws	309
Jeans, Denim	64-65
Jeans, Denim, Women's	71
Jib Adapter Tube	464
Jib Head Roller	448
Jibs	413
Jumper Cable Ferrules	409
Jumper Clamps	397, 408
Jumper Hook	458
Jumper Leads, Electric Meter	459
Jumper-Aid	465
Jumper-T	458

Altec P/N	PAGE
Jungle Formula Insect Repellent	105
Kellems Pulling Grips	237
Keyless Chuck	333, 341
Klein Haven Grips	212
Klein-Kurve	286
Klondike Clamps	465
Klondike Pins	465
Knife Holder	268
Knife, Cable Splicers	268
Knife, Ergo-Blade	57
Knife, Ergonomic	257
Knife, Folding	276
Knife, Lockback	559
Knife, Pocket	268, 463
Knife, Skinning	263, 268
Knife, Skinning	435
Knife, Utility	261, 275- 276
Knocker Tool, Universal	440
Knuckle Joint	244
Knucklehead	178-179
Labels, Safety	31
Ladder, Hook Epoxiglas	441
Ladders	114-115, 117
Ladders, Epoxiglas Spliced	441
Lamps, Reflective	208
Lantern	177
Lanyard, Chainsaw	569
Lanyard, Positioning	560
Lanyard, Shock Absorbing	562
Lanyards	36, 44, 45, 56
Lanyards, Arborist	567-568
Lasher, Cable	508
Lashing Wire, Stainless Steel	508
Latch Kit	535
Lath Hatchet	557
LB Lever Hoist	225
Leads, Banana	537
Leather Protectors	475
LED Compartment Lighting	164
Leg Strap	51
Legends	187
Light, Tail	171
Lighthoods	190
Lighting	276-210
Lighting, Battery Powered	207
Lighting, LED Compartment	164
Lighting, Pole Trailer Kit	166, 203
Lighting, Reflective	208
Lighting, Safety Lightsticks	164
Lighting, Warning	203
Line Guard	471
Line Hose Bag	125
Line Hose, Connector End	468
Linebacker	49
Lineman Felt Pac Boots	90-91
Lineman Grade Rubber Gloves	472-474
Lineman's Convertible Hoist	227
Lineman's Jacket	66
Lineman's Pliers	277
Linemans Ratchet Lever Hoist	230
Lineman's Strap Hoist	219, 220, 231
Lineman's Wear	72
Linemans Web Hoist	226
Liner - Hard Hat	26
Liner Pads	132
Link Cats Eye	151
Link Stick Head	438
Links, Connecting	498
Litebox	176-177
Litebox Holder	129
Litebox, Hid	179
Litfinger	208, 464
Litlink	208, 464
Load Break Bushing	537
Load Break Cutout Tool	456
Load Break Elbow	537
Load Break Tool	450
Load Deck	112
Loadbreak Bushing Installation Tool	461
Loadbuster	464
Load-N-Go	112
Load-Ranger Load Break Tool	450
Locators, Cable & Pipe	489
Locking Dog Assembly	416

Altec P/N	PAGE
Locks	171
Logging Meter	543
Long Haul Rope Pullers	225
Long Nose Pliers	277
Long Reach Saw	372
LSB Hoist	218
Lube Spreader Swab	486
Lug Hook	110
Lug Hooks	572
Lunar Ladders	114
Magnet Lights	186
Mandrels	494
Manhold Ladders	492
Manhole Equipment	493
Manhole Sheaves	499
Manual Pouch	164
Mast Assembly	447
Material Handling Accessories	413
Mat-Paks	141
Mats, Ground Protection	141
Mats, Industrial	132
Measure, Tape	278
Measuring & Disconnect Stick	426
Measuring Stick, Tel-O-Pole	443
Measuring Telescopic Hot Stick	453
Mechanical Hoists	221
Megohmmeter	541
Merlin ACSR Cutters	307
Metal Cutting Saw	337
Meter Grabber	459
Meter, Clamp	538, 549
Meter, Fork	538
Meter, Laser Distance	539
Meter, Phase Rotation	537
Meter, Standard	545
Meter, Tension	536
Meters, Cable Length	541
Meters, Clamp	540
Meters, Dual Range	545
Micropulse	188
Mid Pole Strobes	203
Mini Hoist	218
Mini Triple Square Wrench	283
Missile Line Carriers	496
MKB Evolution Hard Hat	25
Mobile Camera Systems	147, 189
Mobile Desks	144-150
Mobile Tool Chest	122
Moisture Eater II Wipes	434
Motor Rotation Indicator	541
Mud Bucket	116
Mud Flaps	164
Multimeter, Auto-Ranging	549
Multimeter, Electricians	539, 541- 543, 549
Multi-Purpose Tool	286, 315
Multi-Tool	260
Multi-Tool, Pad Mount	491
Nail Eater Extreme Bits	350
Nail Eater II Bits	350
Narrow Stik	197
Neutral Detector	552
Nightray Spotlight	195
Non-Slip Protection	165
Nozzles, Cable Feeder	499
Nut & Bolt Bag	57
Nut Driver	262
Nut Driver Set	260
Nut Runner	349, 373
Nutdrivers	270
Nylon Block	253
Nylon Slings	248
Nylon Strap Hoist	221
Oil Spill Ecoabsorb	118
Omega Outerwear	83
Outerwear - High Visibility	82-83
Outlet At Boom Tip	168
Outrigger Pad Holders	167
Outrigger Pads	23, 140, 141
Overalls	67
Overlays (Signs)	16
Overshoes, Work Rubber	96, 480
Ox Block	52-53
Pack N' Pop Safety Cone	22, 164
Pad Mount Multi-Tool	491

Altec P/N	PAGE
Paddle, Stop/Slow	20, 574
Pads, Liner	132
Pads, Outrigger	140-141
Pads, Scuff	132
Pants, Cargo	65
Pants, Work	65
Parallel Jaw Grips	213
Para-Pak Rescue Device	40
Parka	70
Patriot Series	320-321
Paving Breakers, Hydraulic	356
Payout Reel	160
Peavies	110, 572
Pedestal Desks	144-150
Penta Socket	265, 365, 373
Penta Socket Driver	462
Penta Wrench	365
Phase Rotation Meter	537
Phase Sequence Indicator	541
Phasing Digital	550
Phasing Meter	552
Phasing Ranger	550
Pilot Bits	523
Pilot Kits	521
Pilot Line Controller	256
Pins, Klondike	465
Pins, Rubber Blanket	471
Pintle Hooks	167
Pioneer Plus	191
Pipe Shears	297
Pipe Stands	117
Pipe Wrenches	259
Pistons, Conduit	486
Placard, Warning	410
Plastisol Hanger	455
Plate, Striker	171
Platform Covers	135
Platform Mounted Tool Tray	127
Platform Rest Tube	164
Platform, Standard Aerial	441
Pliers, All Angle Hotline	438
Pliers, Cutting	261
Pliers, Diagonal	277
Pliers, Linemans	277
Pliers, Locking	273, 278
Pliers, Long Nose	277
Pliers, Pivot Pro	271
Pliers, Pump	261, 264
Pliers, Reaming	277
Pliers, Side-Cutting	261, 264, 274
Pliers, Tongue & Groove	277
Pneumatic Impact Wrench	389
Pneumatic Tamper	389
Pocket Knife	463
Pole & Clamp Hanger	435
Pole Bug	202
Pole Climbers	50
Pole Covers	467
Pole Danny	117
Pole Framing Jack	117
Pole Lifting Tongs	117
Pole Pruner, Gas Powered	381
Pole Puller, Hydraulic	355, 367, 372, 374
Pole Punch	265
Pole Qwikset	106
Pole Saws	570
Pole Setting Foam	106
Pole Sling	248
Pole Storage Bag	570
Pole Tacker	202
Pole Tamper	354, 368
Pole Top Block	255
Pole Trailer Lighting	203, 205
Pole Wire Tong Saddle	422
Pole Wrap	22
Poleprop	117
Poles, Fiberglass	576
Polo Shirts	59-61
Polytac Flashlights	183
Portable Scene Light	180
Positioning Strap	59
Pouch For Manual	164
Pouch, EK425	129, 309

Altec P/N	PAGE
Pouches, Tool	259
Power Fuse Bypass Tool	456
Power Pump	350
Power Systems	393
Power Unit	382
Power Unit	383
Power Unit, Hydraulic	360, 391
Powerblade Cable Cutters	307
Power-Line Boots	87-88
Power-Pull Strap Hoist	225
Pressure Digger Augers	519-520
Priority Start Promax	163
Probe Insertion Tool	292
Probe Installation Tools	461
Profiler li	210
Pro-Gear Elite Coolers	138
Protac Flashlights	183
Pruner	275
Pruner Poles	571
Pruner Adapter	571
Pruner Holder	128
Pruner, Pole	372, 381
Pruner, Utility	358
Pruners	571
Pruners, Center-Cut	571
Prusik Loop	568
Pry Bars	274
Puller Hoists	225
Puller, Cable	482, 484
Puller, Sign Post	354
Pulley	53
Pulling Collars	242
Pulling Eyes	248
Pulling Eyes, Interduct	498
Pulling Frames	500
Pulling Grips	237-238, 507
Pulling Grips Selection Guide	242
Pulling Grips, Underground	498
Pulling Trailer	501
Pulsator	188
Pump, Hydraulic	367
Pump, Hydraulic Electric Powered	364
Pump, Hydraulic Gas Powered	364
Pump, Power	350
Pump, Submersible	357
Pump, Submersible	371
Pump, Water	384
Punch	274
Punch-Lok Bands	237
Pvc Boots	96
Quad-Point Crimping Tools	311
Quadrant Blocks	499
Quadrant Block	492
Quick Change Augers	515
Quick Disconnects	375
Racks For Coolers	168
Radioray	198-199
Rainwear, High Visibility	80-81
Ratchet Cutters	295, 303- 305
Ratchet Cutters, Insulated	443
Ratchet Lever Hoist	219, 230
Ratchet Wrench, Hotline Accessory	436
Ratchet Wrenches	279-281
Razor Auger Bits	363
Reaming Plier	277
Reciprocating Saw	388
Reciprocating Saw Kit	325, 336
Rectangular Tool Tray	126
Reel Ball Stop	160
Reel Ball Swivel	160
Reel Buck	504
Reel Caddy	504
Reel Rack System	112
Reel Stand	160
Reel Thing, The	151
Reel Tuff	154
Reel, Storage	256
Reels	152-159, 161
Reflective Lamps	208
Reflective Vest	574
Regulator	384
Remote Heads	350
Replacement	260
Replacement Bits	259
Replacement Parts	377

Altec P/N	PAGE
Rescue Blocks	55
Rescue Buck	563
Rescue Lanyard	44
Rescue System	31, 40, 54
Responder	190
Rest System	40
Ribd-Rubr-Lok	526
Rigging Sling	249
Robo Paks	385
Robo Tool	341
Roboreel	152-153
Rock Drill	355
Rock Ripper Rock Augers	514
Rodders, Conduit	488-489
Roller Grip	285
Roller Link Stick	433
Roller Wire Holder	412
Roll-Up Safety System	20
Rope Adapter	495
Rope Bag	570
Rope Blocks	254
Rope Connector	507
Rope Grab	45
Rope Insulator	568
Rope Lock Device Tool	223
Rope Pail Haul Bag	57
Rope Sling	561
Rope Storage Reel	507
Rope, Arbormaster	564
Rope, Arbor-Plex	564
Rope, Replacement	256
Rope, Safety Blue	565
Rope, Stable Braid	564
Rope, Tachyon	565
Ropes	561-533
Ropes, Arborist	564-569
Rota-Beam	190
Rotary Blade Spline Attachment	455
Rotary Hammer (Electric)	385
Round Adapter	412
Round Sling	249
Round Tamp	109
Rowdy's Dirtball	246, 527
Rubber Blanket Roll-Ups	471
Rubber Blankets	465
Rubber Insulating Covers	467, 471
Rubber Insulating Gloves	475-477
Rule	267
Rule, Folding	275
"S" Hooks	125
Saddle	560
Saddle, Crossarm Wire Tong	421
Safety Cone Holders	22, 167
Safety Cones	22, 164, 574
Safety Cones - Pack N' Pop	22
Safety Eyewear	32-35
Safety Glasses	27
Safety Hooks	125
Safety Labels	31
Safety Signs	574
Sahara Heater	169
Sat-85	526
Saw Blades	570
Saw Handle	449
Saw Head Sections	570
Saw, Band	327, 328, 337, 388
Saw, Chain	358, 359, 372, 380
Saw, Circular	326, 358, 372
Saw, Hacksaw	276
Saw, Hand	276
Saw, Keyhole	261
Saw, Long Reach	372
Saw, Metal Cutting	326, 337
Saw, Pruning	449
Saw, Pvc	259
Saw, Reciprocating	336, 388
Saws, Pole	570
Sawzall	325, 328
Scabbard, Chainsaw	569
Scabbards, Leather	562
Scene Light	180, 204
Scissors & Knife Set	259
Scorers & Strippers	287
Scorers, Semi-Con	290

Altec P/N	PAGE
Scorpion Flashlights	184
Scotchlite	169
Screen Out	149
Screw Anchor Equipment	415
Screw Ground Rod	402, 409
Screw Jack Assembly	438
Screw Pin Shackles	534
Screwdriver	262
Screwdriver Set	260, 263, 278
Screwdriver Tool	438
Screwdriver, Conduit Reaming	261
Screwdriver, Twist-A-Nut	257
Screwdrivers	270
Scuff Pads	132
Sealed-Blok	45
Seals, Rubber	170
Seat Rack - Hard Hat	26
Seat-Belt Lineman Belt	43
Secondary Lanyard	47
Select Step Ladders	115
Self Rescue System	54
Self Rescue System	54, 55, 563
Self-Retracting Lifeline	45
Semi-Con Edge Wedge	285
Semi-Con Roller Grip	285
Semi-Oval Tool Tray	127
Sentinel Outerwear	82-83
Sentry	188
Septor Headlamp	182
Sequential Light	210
Service Tester	551
Sh-85	526
Shackles	250, 252
Shackles, Screw Pin	534
Shaft Adapters	522
Shank Plates	521
Sharpener, Knife	505
Sheave & Shackle	502
Sheave Head, Aluminum	464
Sheave, Universal Swivel	503
Sheaves, Cable	500
Sheaves, Cable Feeding	497
Sheaves, Manhole	499
Shepherd Hook	438
Shield Mini Bar	197
Ship Auger Bits	332
Shirt, Button-Down	63
Shirt, FR	67
Shirt, High Visibility	67, 85
Shirt, Uniform	63
Shirts, Button Down	76
Shirts, Henley	75
Shirts, T-Shirts	75
Shockwave 2	44
Shoe String Cutter	455
Shoes, Cable Bending	497
Shotgun Sticks	423-424, 442
Shotgun Sticks	454
Side Cutter, Insulated	263
Siege Lantern	177
Sight Rods	168
Sign Accessories	18, 19
Sign Overlays	16
Sign Post Driver	354
Sign Post Puller	354
Sign- Roll-Up	21
Sign Stand	18, 20, 574
Sign, Safety	574
Signal Master	187
Signs	17, 20
Silicone Bushing Cover	468
Silicone Hot Stick Cloth	455
Silicone Wipes	434
Simulator, Transformer	537
Skid Protection	165
Skidding Tongs	109, 572
Sled, Cable Pulling	505
Sledge Hammer	116, 557
Sleeve Bags	103, 474, 480
Sleeve Straps	474
Sling, Adjustable	53
Sling, Pole	248
Slings, Chain	248
Slings, Nylon	248

Altec P/N	PAGE
Slings, Rigging	249
Slings, Round	249
Slings, Transformer	249
Slings, Wire Rope	248
Slotted Blanket	466
Slr Beacon	187
Snap Hook	234
Snatch Blocks	253, 254, 534
Socket, Adjuster	438, 440
Socket, Double Square	365
Socket, Lineman's	368
Socket, Penta	285, 365
Sockets	267, 373
Sockets, Deep Well	278
Sockets, Hex	430
Sockets, Impact	282, 373
Soft Cover, Tool Trays	127
Solid Blanket	466
Solid Core Auger Bits	363
Spanner Wrench	371
Spider Pilot Line System	256
Spidreflex Rope	256
Spiral Disconnect Tool	440
Spiral Link Stick	433
Spiral Link Stick, Insulated	442
Splice, Ground Cable	408
Splice/T-Body Tool	290
Spliced Switch Sticks	444, 445
Splicer Platform Cover	135
Splicer Tool Tray	126
Splicers Box	129
Splicer's Kit	505
Splicer's Seat	134
Splicer's Toolbox	134
Spline Attachment	455
Spool & Shackle	535
Spoon Shovel Blade	108
Spotlight	191, 195, 210
Spreader Bar	441
Stable Braid Rope	564
Stacker Sign Stand	21
Stand, Reel	160
Standard Web Strap Pullers	229
Stands, Hose	492
Stapler, Pneumatic	389
Starting Block	506
Sta-Set Rigging Rope	566
Static Ground Set	402
Steel Toe Overshoes	96
Step Rock Augers	513
Step, Fiberglass	134
Step, Swing	168
Steps, Cable	168
Stinger Cover	468
Stinger Flashlights	184
Stop, Reel Ball	160
Storage Reel	256
Straight Shovels	108
Strap Hoist	231
Strap Puller Hoist	225
Straps, Gut	49
Straps, Sleeve	474, 480
Stray Voltage Detector	548
Streamlight Jr	185
Striker Plate	171
Stringing Block	255
Stringing Controller	255
Stringlights	186
Strion Led Hl	185
Strip-Lite	191
Strip-N-Coil	491
Stripper, Cable	288
Stripper, End	292
Stripper, End (Power Driven)	291
Stripper, Mid-Span	290
Stripper, Universal Cable	289
Strippers, Insulation	290
Strippers, Wire	286-287
Stripping, Adhesive	170
Strobe Beacon	197
Strobes, Poles	203
Stryker	198-199
Stud Covers	402
Stylus Pro	185
Submersible Pump	357, 371
Sumostance Ladders	114

Altec P/N	PAGE
Sun Shield	26
Sunscreen	105
Superjack Pipe Stands	117
Supersqueeze	47
Super-Sta M	165
Superstrap	47
Support Bar	492
Surfacing Material	165
Suspension Link Stick	433
Suspension Rescue System	54
Suspension Yoke, Strain Pole	439
Swab, Lube Spreader	486
Swabs, Rubber Duct	494
Sweatband - Hard Hat	27
Sweatshirt	68-69
Sweatshirt, High Visibility	77, 85
Swing Links	242
Swing Step	168
Switch Barrier	467
Switch Hot Sticks	445
Switching Tool, Tension Puller	419
Swivel Anchor Hook	234
Swivel Base Truck Mount	223
Swivel Base Truck Mount	224
Swivel Hook	535
Swivel Hook Plunger	234
Swivel Support	448
Swivel Top Gin	423
Swivel, Hydraulic Reel Ball	160
Swivels	534
Swivels, Ball Bearing	244, 497, 507
Swivels, Break-Away	502
Tachyon Rope	565
Tail Light	171
Tamper, Pneumatic	389
Tamper, Pole	354, 368
Tamping Bar	417
Tap And Die Tools	285
Tape, Measuring	260, 275, 278, 486
Tarp, Auger	246, 527
Tarps, Jobsite	246, 527
Telescopic Hot Stick	427, 453
Tel-O-Pole Hot Sticks	443
Tel-O-Pole Measuring Stick	443
Temp-Gun, Laser	539
Temporary Cutout Tools	421
Temporary Ground Rod	410
Tension Meter	536
Tension Puller	421
Terminal Block, 4 Way	401
Test Gauges	364
Test, Fluorescent Lighting	538
Tester, Capacitor	552
Tester, Digital Phasing	545
Tester, Electrical	541
Tester, Gas Lamp	541
Tester, Ground Resistance	540
Tester, Grounding	545
Tester, Grounds	537
Tester, Hot Stick	545
Tester, Service	551
Tester, Transformer	552
Tester, Voltage	542
The Reel Thing	151
Thermal Imager	539
Thermometer Temp-Gun	539
Thinsulate Lineman Pac Boots	89
Tie Head	436
Tie Stick Head	436
Tie Wire Claw Tool	435
Tip Driver Set	260
Tire Pressure Maintenance	151
Tongs, Pole Lifting	117
Tongs, Skidding	572
Tongue & Groove Pliers	277
Tool Adapter, Universal	435
Tool Apron	131
Tool Assemblies, Hydraulic	377-379
Tool Bags	118, 125
Tool Belts	36
Tool Board	122, 133, 573
Tool Bucket, Round	570
Tool Buckets	121-124
Tool Chest	122

Altec P/N	PAGE
Tool Grippers, Elbow Connector	432
Tool Hanger, Crossarm	436
Tool Hoses	376
Tool Kit, Electricians	258
Tool Kit, Journeymans	258
Tool Kits, For Clevis Type Insulators	430
Tool Organizer Boards	130, 573
Tool Rack	440
Tool Trays	122, 133, 126
Tool, Crimping	320
Torch	384
Torque Indicators	418
Tower Wrenches	283
Tracer, Circuit	543
Traffic Indicator	210
Transformer Dolly	113
Transformer Gin	423
Transformer Simulator	537
Transformer Sling	249
Transformer Tester	552
Trauma Strap	45
Travelers, Bttv	255
Traveling Ground	411
Trays, Tool	26, 133
Tree Climbers	58, 561
Tree Pruner, Universal	449
Tree, Die	320
T-Rex Light	197
Trident Headlamp	182
Trimax Augers	518
Tri-Penta Wrench	462
Triple Square Impact Socket	282
Triple Square Wrench	283
Tripod Sign Stand	21
Trouble Shooter Kit	432
Truck Barricade Kit	446, 447
Truck Ground	411
Truck Grounding Set	403
Truck Mount Rescue System	40
Truck, Die Cast Toy	14-15
T-Shirts	59, 60, 62, 75
Tubular Storage Kit	162
Turboflare	22
Two Wheel Dolly	113
Twoover Rescue Blocks	55
U-Bail Grips	239
UltraStar Led	187
UltraStar Us5	188
Umbrella	504
Uniflex Sign Stand	21
Universal Bracket/Chain Clamp	222
Universal Cutout Tool	440
Universal Dolly	113
Universal Fitting	426
Universal Head - Splined	449
Universal Hotstick Probe	455
Universal Knocker Tool	440
Universal Poles	429
Universal Rotary Blade	449
Universal Spill Kit	104
Universal Sticks	427-429
Universal Tool	435
Universal Tree Pruner	449
Univorm Short	63
Urd Wrench	491
Utility Augers	510-526
Utility Knife	276
Utility Light	573
Valves	361
Vehicle Backup Alarm	169
Velcro Wrap	51
Ventilators	490
Vertical Tower Attachment	441
Vest, High Visibility	77, 85
Vest, Reflective	574
V-Gard Hard Hat	26
Vinyl Equipment Bag	559
Visibeam	189
Vision FR Outerwear	81
Voltage Detector	542, 544, 547, 548, 551, 552, 553
Voltmeters, Digital	546

Altec P/N	PAGE
V-Watch Voltage Detectors	547
Warming Packs	102
Warning Flag	20
Warning Placard	20, 410
Warning Triangle Kit	22
Wasp And Ant Spray	105
Water Pump	384
Wax, Carnuba	455
Weatherproof Wire Grips	212
Web Hoist	226
Web Sling Shackles	252
Web Strap Pullers	228, 229
Web-Strap Hoist	215
Wheel Check Locking Tab	164
Wheel Chock Holders	167
Wheel Lug Indicators	164
Wide Area Lighting	186
Wildlife Protection	458
Winch, Hydraulic Adss	507
Winch, Intermittent Duty	503
Wind Energy Lanyard	44
Wing Pad	38
Wipes	165
Wipes, Hot Stick	446, 455
Wipes, Moisture Eater	434
Wipes, Silicone	434
Wiping Cloth, Silicone Treated	446
Wire Brush, Dogbone	463
Wire Clamp	509
Wire Pulling Grips	213
Wire Rope Slings	248
Wire Stripper/Cutter	286
Wire Tong	422
Wire Tong Support	421
Wirecutters	425
Wireholder Assembly	464
Wireholder, Roller	412
Wireholders	414
Wireholding Stick	425
Wireless Phasing Meter	553
Wood Rule	267
Workmaster Industrial Mats	132
Wrap Pad	51
Wrench Head	435
Wrench Holster	283
Wrench Set	273
Wrench Tool, Ratchet	435
Wrench, 4-In-1	265
Wrench, Adjustable	261, 266, 272
Wrench, Anchor	416
Wrench, Combination	273
Wrench, Construction	266, 272
Wrench, Hammer Head	257
Wrench, Impact	323, 324, 325, 327, 334, 335, 340, 348, 368
Wrench, Impact (Electric)	385
Wrench, Lineman's	265, 285
Wrench, Penta "T"	365
Wrench, Ratchet	273
Wrench, Ratchet (Hotline Accessory)	436
Wrench, Ratcheting Box	285
Wrench, Spanner	371
Wrench, Transformer	282
Wrench, Tri-Penta	462
Wrenches, Connector	279-281
Wrenches, Distribution	283
Wrenches, Double End	282
Wrenches, Hexagonal	283
Wrenches, Insulated	431
Wrenches, Ratchet	279-281
Wrenches, Torque	273, 303
Wrenches, Tower	283
Wrenches, Triple Square	283
X-Grips	241
Yoke, Deadend	439
Yoke, For Plates (Hotline)	439
Yoke, Steel Arm	439
Yoke, Tower	439
Yoke, Two Pole	439



5610 Corporate Drive
St. Joseph, MO 64507

**FOR PARTS, TOOLS & ACCESSORIES,
Shop Service, or Mobile Service/Technical Support,**

PLEASE CALL

**1-877-GO ALTEC
(1-877-462-5832)**

FAX (24 HOUR): 816-236-1239

www.alteconnect.com